

Protecting ETO Alpha 76A Amplifiers

After acquiring a used Alpha 76A amplifier with 8874 tubes of unknown status, I was very pleased to discover the expensive 8874s were percolating well. However, I was also surprised to find the Alpha amplifier had no built in protective circuitry except for excessive plate current. Reflected power and high grid current protection depended upon the operator monitoring a front-panel meter.

Some of this is welcomed—especially the lack of high reflected power shutdown (I use 75Ω hard-line; the pi network inside the amp will perfectly match this impedance but the 50Ω-referenced wattmeter will claim a mismatch exists). I'd really prefer not having such "protection". However, high grid current will readily damage tubes (did I mention that 8874s are expensive?), so automatically monitoring this parameter is desirable. The circuit presented here monitors grid current and temporarily disables the amplifier if it exceeds a set level. Ideas for extending the protection to reflected power and other fault conditions are also mentioned. This idea should also work with the Alpha 374/A and Alpha 78 amplifiers, which share control circuit design.

Background & System Level Definition

I've used several amplifiers over the years, from sweep tube-based linears through Alpha 87As, including a few solid-state half-kW amps. Protection schemes varied from nothing in most of the amplifiers, to some fairly aggressive designs in the transistorized amps. Fault recovery also varied--some amps latch-off-line until manually reset; others stay off for a "penalty delay", then automatically return to duty. Although I've generally had good luck with my amplifiers, there was a problem here a couple of years ago that caused an arc that took out a band switch. This was due to a guest operator not properly tuning an unprotected AL-1200. After replacing the switch (turns out, an exact replacement was no longer available, so some modifications were needed), parasitic oscillations occurred that destroyed a couple of plate chokes, destroyed test equipment, stressed the power supply, and generally reduced my enthusiasm for both power amplifiers and guest operators!

The 76A has automatic power-off shutdown protecting the amplifier from excessive plate current. Otherwise, amplifier longevity depends upon the operator monitoring the front panel meters, one of which may be switched between grid current, forward power, reflected power, and B+. Two other items were of interest: first, there is a factory-drilled rear panel hole marked "AUX" on the rear panel that might be used to bring out cabling. Another was the characteristics of the amplifier T/R key line. Open circuit (receive/standby mode), it presents +28VDC. When shorted to ground (transmit mode), it sources 70mA while idling, increasing to over 120mA with full output. This is because amplifier grid current flows through the T/R line. A little caution is necessary regarding the switch used in the driver transmitter: voltage drop across this switch will increase the amplifier bias point, causing it to become slightly less linear. Other considerations include the way the amplifier is enabled. Instead of a two-position OPERATE/STANDBY switch, it has a three-position dual push button. With both buttons out, the amplifier is in standby mode. The "CW" button enables the amplifier using the lower voltage transformer tap. The "SSB" button selects the high B+ tap. This design is a relic of the old US maximum power regulation, dictating a maximum of 1000W of DC input power for final stages. The present output power limit is better served with the amp in the "SSB" position full-time. Placing the amplifier into standby is a little bit tricky, requiring the operator depress both the CW and SSB buttons simultaneously; this is too complicated a manoeuver during a contest when one's hands are better kept on the keyboard



The Alpha 76A. Yes, this is a lousy photograph.

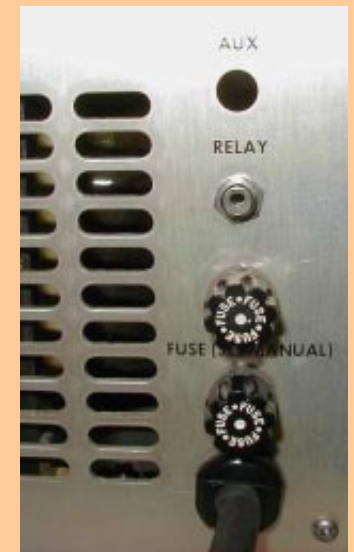

Photo 2. The rear panel has a factory-drilled hole above the T/R (RELAY) input.

I studied the protection schemes used in the Ameritron AL-1500 and the Alpha 91 β amplifiers. The AL-1500 latches itself off-line if a grid current fault occurs. The lamps on one of the front panel meters darkens and operator must manually toggle the OPERATE/STANDBY switch to return to operation. The 91 β shuts off all power if plate current is excessive, and switches off-line for several seconds if grid current or reflected power is high, or if throughput gain is low. Its delay time may be circumvented by manually toggling its standby switch.

The 76A already has over-plate current shutdown, and a gain monitor is both complicated and does not contribute much if grid current is watched. I did not want a reflected-power limit. This meant the only other feature necessary to keep my 76A tubes happy and long-lived was automatic grid current monitoring. Since surgery was planned anyway, a proper solid-state T/R switch might as well be implemented to reduce the control switching requirements of the driving transmitter.

Decisions, Decisions

Once the goal was defined, several circuits were designed. One, a fully manual reset design, fires a transistor latch when high grid current flows and uses an external reset push button. Another uses an external box with a LM3914 LED bar graph driver that provides a moving display of grid current and fires a latch when the current pins the virtual meter. The manual reset circuit did not provide a visible indicator when the amplifier was switched off-line. The bar graph display circuit worked OK, but is a rather complicated way to solve a simple problem. This complexity is partially due to the way cut-off bias is implemented in the 76A. In Standby mode (either via the front-panel "CW/SSB" switch or when the amplifier is in receive mode), both sides of the grid current sense resistor float at 28V above chassis. When activated, the grid (actually, the cathode) side drops to about 5V. While the LM3914 will operate under these conditions, I worry that basic amplifier operation might be affected by transient current flow during T/R switching after the proper amount of bypass capacitance is added. Both of these grid protection circuits required external wiring through the rear-panel AUX hole.

The implemented design is of intermediate complexity and requires no external wiring nor operator intervention. It uses common, unexciting parts in a straightforward circuit: an optoisolator, a venerable 555 timer, a voltage regulator, a low resistance N-channel power MOSFET, three low-cost bipolar transistors, and a few resistors and capacitors. Often, the most expensive portion of my designs are the connectors; this design requires none. This protection circuit does not affect amplifier operation in any way—until a grid current fault is detected.

Da Design

The circuit is shown in Figure 1. Grid current is detected by the 10 Ω resistor (R116 on the 76A's High Voltage & Control PCB), and is fed to the optoisolator via R1. When the optoisolator reaches threshold, it triggers the 555 timer (U2). This immediately forces the amplifier into standby mode and illuminates lamp B1. As long as the T/R line from the transmitter remains low, the amplifier remains latched off. Reset delay timing does not begin until this line pulls high (receive mode); this feature prevents hot switching the amplifier back on-line during a long transmission. Once the T/R line does go high, the short (switched in by Q2) across timing capacitor C1 is removed and the reset time interval begins. This interval is set by the product of R_t and C1. After it expires, the timer output drops low, B1 extinguishes and the amplifier is again ready for use. However, if the T/R line toggles low

Protection Features

1. High Grid Current Protection
2. Solid State T/R Switching (no relay, low switch resistance)
3. Internal Installation (no external wires/switches, etc.)
4. Automatic Reset after "Penalty" Delay



Photo 3. The innards. Rear panel at top, front panel at bottom. The 8874s live in the top left compartment. The Pi-L network is at the lower left. The RELAY jack is at top center, near the power transformer. The High Voltage & Control PCB covers the lower right quadrant.

The grid overcurrent detect threshold is set by R1 working with the inherent forward voltage drop of the optoisolator (about 1.0 to 1.25V nominally). Since the optoisolator is operating at its threshold, the output load current represented by the 555 trigger pull-up resistor R2 is also important. 100kΩ is a good value for this resistor; if you use a different value, R1 might require adjustment. Further, as the amplifier heats up, the optoisolator threshold voltage drops a bit, which effectively drops the overcurrent detect limit. This drop is small because the optoisolator is located in the intake air stream, and does not significantly affect circuit performance. Remember, we are looking for fault protection; as long as the circuit allows normal grid currents of approximately 50 to 75mA and protects when this current reaches 150 to 200mA, all is satisfactory.

The detect threshold current may be calculated as:

$$I_{G(\text{Shut-off})} = 100 \times R1(\text{k}\Omega)$$

Where I_G is in mA and R1 in kΩ.

An R1 value of 1.5kΩ resulted in a grid current threshold of 150mA. Using 2kΩ gave 200mA. While a variable resistor may be used, it really isn't necessary. I was tempted to use the 1.5kΩ resistor already on the control board (R117), but decided against it. If this resistor used, the internal grid current meter will provide inaccurately low readings due to the optoisolator loading it down.

Construction and Installation

My prototype was assembled using standard perfboard. The board is mounted on the rear panel of the amplifier through one slot of the ventilation air intake using a small bolt, washers and a nut (Photo 4). But before mounting it, disconnect the wire on the "RELAY" phono jack on the rear panel of the amplifier. This wire will connect to the new board, and the T/R line from the drain of Q1 replaces it on the jack. Four wires are routed to the 76A's High Voltage & Control PCB as shown in Photo 5. The current sense wires are tacked across R116, ensuring the anode side of the optoisolator goes to the R115 side of R116. Supply and ground connections are obtained by tapping across the 28V supply filter capacitor, C108. (NOTE: my schematic shows this is a 500μF capacitor, but my amplifier uses a 470μF—no worries, though!). One or two wires route the indicator bulb B1 up behind one of the translucent meter faces so it is visible when it illuminates.



Photo 4. The board is installed on the rear panel between the power transformer and the tube compartment.

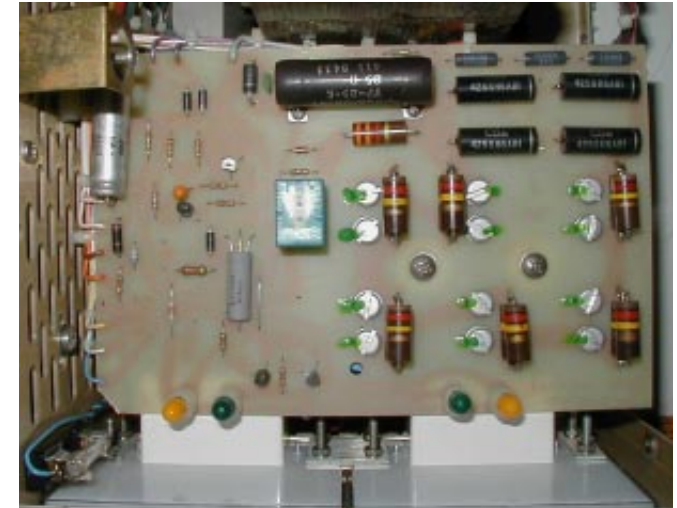

Photo 5. Control PCB, with front panel at bottom. The components we hook onto are on the left side of the board. Indicator lamp B1 (not shown) should rest against the translucent face of one of the meters (bottom). Ensure all wires are well insulated since those exposed bolt heads and 2W resistors are high voltage points!

Operation

After installation, the top cover was reinstalled and the amp fired up. Normal operation at full power was verified, then the loading control was purposefully mistuned. As the grid current hit 150mA (full scale on the internal meter), the amp kicked off-line. After a couple of seconds, the transmitter

was keyed with lower drive. The amplifier responded by amplifying until the increasing drive again caused the grid current to exceed 150mA, where it again kicked off. Maintaining key-down on the transmitter, the amplifier remained off-line. Toggling the T/R line with receive periods less than about a second kept the amp off-line, but as soon as a receive period exceeding a second and a half or so occurred, the amplifier was rearmed and ready to try again, just as expected. Imagine that!

No RF susceptibility problems have yet been detected.

Circuit Additions

This basic circuit may be expanded if further protection parameters are desired. Since reflected power measurement is already provided by the amplifier, it may be added to the protective parameters with a comparator, a few resistors and a diode. Figure 2 shows a possible configuration.

When the reflected power rises, the watt meter's reflected power bridge outputs an increasing current to R_{Ra} and R_{Rb} . This level is compared to the voltage set by R_A and R_B . If the reflected power is too high, the comparator switches high, which triggers the 555 timer through D1. The remainder of the protection circuit functions the same as before.

Another important parameter is exhaust air temperature. This might be implemented with another comparator and a temperature sensor, either silicon or bimetallic. On the other hand, if the exhaust air is too hot, a much longer delay time is probably warranted!

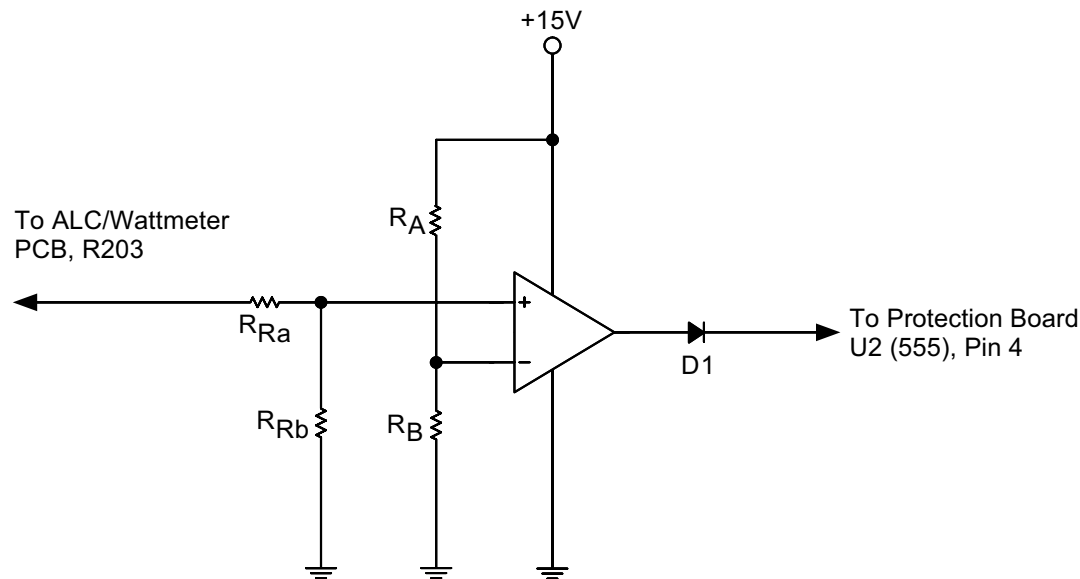

Figure 2. Adding High Reflected Power Protection

Conclusion

While I'm sure that some day my 8874s will bite the dust, I believe that day has been delayed a bit by the inclusion of overcurrent protection. I am working on a clean PC board version of this circuit. Is anyone interested?