

PRICE: \$10.00

# OPERATING AND TECHNICAL MANUAL

HIGH FREQUENCY LINEAR POWER AMPLIFIERS

ALPHA 77Dx and ALPHA 77Sx

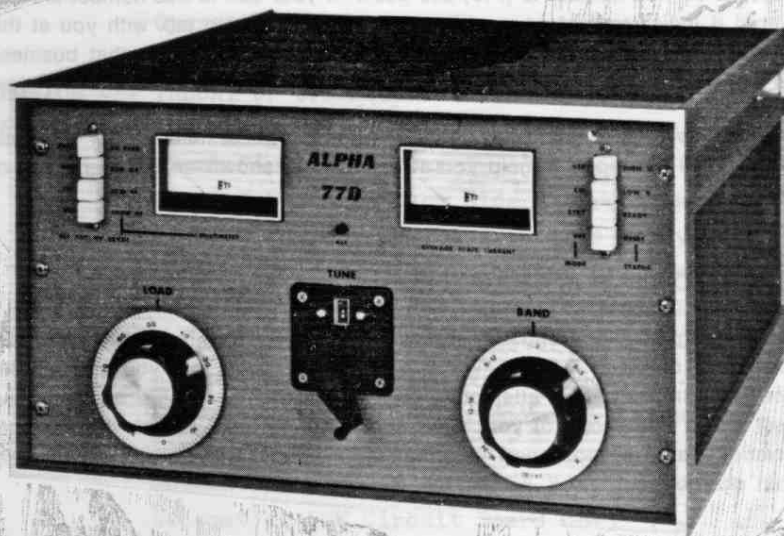

**ETO** EHRHORN TECHNOLOGICAL OPERATIONS, INC.

JANUARY 1990

Scanned by IW1AXR   
  
Downloaded by   
Amateur Radio Directory

---

# **IMPORTANT**

## **SERVICE ASSISTANCE**

To help you secure technical assistance without wasted long distance calls, ETO has established a special SERVICE telephone line WHICH WILL BE ANSWERED ONLY WHEN A QUALIFIED SERVICE TECHNICIAN IS AVAILABLE TO HELP YOU IMMEDIATELY.

The special service number is (719) 599-3861. If your call to this number is NOT answered it indicates that no qualified technician is free to talk with you at the moment. Please wait a few minutes and try again. NOTE ALSO that business hours are 8:30 A.M. to 4:30 P.M. MOUNTAIN TIME Monday through Thursday.

If your call does NOT relate to service or other technical matters, our business office staff will be happy to help you at the number shown on the rear cover of this manual.

## **TEN METER OPERATION OF YOUR ALPHA**

FCC rules permit an appropriately licensed amateur to modify his own amplifier for operation on 28-29.7 MHz. We strongly recommend that you contact our service department before attempting any modification. (If you enclose your request and a photocopy of your valid amateur radio license with the warranty registration card for your new amplifier, appropriate information will be sent without charge.)

## **THE EXPECTED NEW 10, 18 and 24 MHz AMATEUR BANDS**

If and when FCC permits amateur use of these bands with linear amplifiers, your ALPHA will be capable of 10 and 18 MHz operation with only slight modification. In the somewhat unlikely event that high power operation is eventually permitted on 24 MHz, ETO may make available information to permit safe operation of your ALPHA on that band. ANY ATTEMPT TO OPERATE YOUR ALPHA IN THE VICINITY OF 24 MHz WITHOUT APPROPRIATE MODIFICATION MAY CAUSE SERIOUS DAMAGE.

TABLE OF CONTENTS

SECTION 1 - GENERAL DESCRIPTION & SPECIFICATIONS . . . . . 1

SECTION 2 - INSTALLATION . . . . . 2

    Electrical Installation (AC Power Wiring) . . . . . 2

    RF and Control Connections . . . . . 5

SECTION 3 - OPERATION . . . . . 8

    Control Positions . . . . . 8

    Tune-up Procedure . . . . . 9

    Final Operational Adjustments & Monitoring . . . . . 11

    Operating Notes . . . . . 12

    Troubleshooting Hints . . . . . 14

SECTION 4 - THEORY OF OPERATION . . . . . 16

SECTION 5 - ILLUSTRATIONS . . . . . 21

    Front Panel; Rear Panel . . . . . 21

    Front Sub-panel; Back Side of Front Panel . . . . . 22

    RF Section, Top and Side, Covers Removed . . . . . 23

    Power Supply Section, Side and Oblique . . . . . 24

    Tube Deck, Underside; Circuit Board CB-2 . . . . . 25

    Circuit Board CB-3; Wattmeter . . . . . 26

    Schematic, RF Section & Tube Deck . . . . . 27

    Schematic, Power Supply & Main Chassis . . . . . 28

    Schematic, Front Panel . . . . . 29

    Schematic, Circuit Board CB-2 . . . . . 30

    Schematic, QSK Circuit Board CB-3 . . . . . 31

SECTION 6 - STANDARD ELECTRICAL PARTS LIST . . . . . 32

ETO/"ALPHA" PRODUCT WARRANTY . . . . . Outside Back Cover

EHRHORN TECHNOLOGICAL OPERATIONS, INC.  
4975 NORTH 30TH STREET  
COLORADO SPRINGS, COLORADO 80919 U.S.A.

REV. 1/90 @ U.S.A.

## SECTION 1

### GENERAL DESCRIPTION

The ALPHA 77Dx (type accepted model PA-77DF and government/export model PA-77Dx)\* is a high power HF linear amplifier of exceptional quality, ruggedness, and sophisticated design. It is much smaller than other amplifiers of comparable capability, yet provides greater operational versatility, cooler operation, and a lower acoustical noise level than much larger and heavier units.

Unique design features of the ALPHA 77Dx include ETO's exclusive full-cabinet ducted air cooling system, built-in CW break-in keying system, frequency coverage down to 1.8 MHz, and a highly efficient custom power transformer using a tape-wound core of grain-oriented silicon steel. High efficiency of operation is maintained across the tuning range by a combination of vacuum variable output tuning capacitor and ETO's expertly designed mixture of silver plated, heavy copper tubing coils and multi-insulated, toroidal inductors.

### SPECIFICATIONS (Models PA-77DF and PA-77Dx)

Frequency Coverage: 1.8-2.0 and 3-24 MHz (&24-30 MHz, PA-77Dx only).

Plate Power Input: PA-77DF 2.5 KW PEP/SSB, 1 KW average d-c, all modes, no time limit; PA-77Dx 3.5 KW PEP, 2 KW d-c average, NTL.

Plate Efficiency: Typically 60% or better.

Drive Power: Nominal 60-70 watts carrier, 100-150 watts PEP.

Input & Output Impedances: Nominal 50 ohms unbalanced; VSWR under 2:1.

Distortion: Third order IM more than 36 dB below 1.5 KW PEP output.

Harmonics: More than 50 dB below mean fundamental frequency output.

Tube Complement: One Eimac 8877 ceramic triode, grounded grid.

Cooling: Full-cabinet ducted forced air; ball bearing centrif. blower.

ALC: Adjustable-threshold, grid-current-derived, negative going.

Protection: Primary and step-start fuses, plate overcurrent solenoid, a-c line and high voltage cover interlocks.

Primary Power: 220-250V with grounded center neutral, 50-60 Hz, standard. Simple re-connection accommodates 110-125V, 120-208V, or 220-250V without center neutral. 240V supply with 20A fuses or slow breakers is adequate for all-mode operation at full ratings.

Size & Weight: 11"h. x 19"w. x 22"d. (28 x 48 x 56 cm). Net weight 95 lb. (43 kg), shipping weight 125 lb. (57 kg) in two cartons.

### VARIATIONS FOR GOVERNMENT/EXPORT-ONLY MODEL ALPHA 77Sx (PA-77Sx):

Same as ALPHA 77Dx (PA-77Dx) above except two 8877 tubes permit greater PEP input and output power. Approximately 175 watts drive for maximum output. Net wt. 105 lb. (48 kg), shipping weight 130 lb. (59 kg).

\*NOTE: Only FCC type-accepted model PA-77DF may legally be sold within the U.S. except to government customers. PA-77Dx & PA-77Sx available only for export and government customers.

## SECTION 2

### INSTALLATION

1. Unpacking: Carefully remove amplifier and transformer from cartons; SAVE ALL PACKING MATERIAL FOR RE-USE -- SHIPMENT OF ALPHA 77Dx IN OTHER THAN FACTORY PACKING MAY RESULT IN DAMAGE NOT COVERED UNDER WARRANTY @@@

Remove top cover and insure that both plug-in circuit boards are firmly seated in their sockets. Confirm that the TUNE control operates smoothly and reaches a firm mechanical stop at its full clockwise rotation. If your TUNE counter reading decreases with clockwise rotation, it should stop between 000 and 010; if it is a type that increases with clockwise rotation of the crank, it should stop near 190-200. There is no hard stop at full counter-clockwise rotation and caution must be used to avoid turning the crank beyond the normal end of rotation (counter reading of approximately 240 or 000, depending on type as above).

Inspect inside and out closely for evidence of shipping damage; if any is found, notify delivering carrier at once. Complete the enclosed warranty registration form and mail it to ETO. @

2. Transformer Installation: Orient the transformer so that the two multi-pin, molded plugs on the transformer harness point toward the rear of the amplifier; move the corresponding mating connectors in the amplifier out of the way, and make certain that the transformer mounting area is clear of packing material and all wires. USE EXTREME CAUTION LOWERING THE TRANSFORMER INTO PLACE TO AVOID DAMAGING ADJACENT COMPONENTS OR WIRING. It may be desirable to rig a simple sling of strong cord or glass filament tape to aid in supporting and controlling the heavy transformer while lowering it into place.

Install the bolts provided to secure the transformer. Check both pairs of connectors visually for proper mating orientation (avoid excessive harness bending or twisting, as it may cause damage to wires or connector pins) and mate them firmly, pushing until the integral latches engage. Insure that all wires are dressed well clear of the HV rectifier board and HV-shorting crowbar switch. Make certain that the crowbar arm swings freely. THIS CROWBAR IS AN IMPORTANT SAFETY FEATURE; DO NOT DISABLE IT AND DO NOT @ APPLY AC POWER TO THE AMPLIFIER WITH THE COVER OPEN.

3. Electrical Installation: The ALPHA 77Dx and 77Sx are normally shipped wired for U.S.-standard 120/240V (120-N-120), 3 wire, 50-60 Hz, single phase power (grounded neutral). If the amplifier is to be used with this service configuration or has been factory-connected for your alternate arrangement, the top cover may be replaced and secured. If change-over to operate on 220-250V without center neutral, or on 110-125V service, is necessary, proceed as follows first:

Re-connection for operation on 220-250V without center neutral -

- (a) Locate the 7-lug tie strip at the right, rear of the cabinet, along the right edge of the circuit board shelf. The lugs on this strip (TS-1) are numbered from #1 at front to

#7 at the back. The standard wiring to TS-1 (for 120/240V with center neutral) is as follows: (See Fig. 1, page 4)

LUG 1 -- Ground (mounting foot for terminal strip)  
LUG 2 -- White/black wire  
LUG 3 -- White wire  
LUG 4 -- Green, red, white/green & white/orange wires \*  
LUG 5 -- White/violet wire and one blower wire (gray or blk)  
LUG 6 -- Black wire \*  
LUG 7 -- Ground foot; gray wires

\* A tubular capacitor is connected also from #4 to #6.

- (b) Remove the white/green wire only from LUG 4 and connect it instead to LUG 2. (See Fig. 2, page 4)
- (c) Add a new resistor (700 ohms, .8 to 12 watt) between LUG 3 and LUG 4; keep it clear of all wires and parts.
- (d) Remove the cover from the 6 pin connector on the AC power cable; remove the wire jumper connected between pins 10 and 11. Pin 11 is then blank and unused; only the green power cable wire (chassis) goes to pin 10.
- (e) Replace power connector cover and amplifier top cover.
- (f) The 240V service wires connect to black and white wires of the cable; green goes to ground only.

Re-connection for operation on 110-125V service - All required re-connections are made inside the power cable connector itself; remove its cover. (See Figure 5, page 4)

- (a) Remove the existing jumper wire between pins 7 and 9. Remove also the jumper wire between pins 10 and 11.
- (b) Add a new jumper wire from pin 7 through pin 12 and on to pin 11. Add another jumper wire from pin 8 to pin 9. Replace cap on connector.
- (c) The 120V AC service wires connect to the black (from pins 8 & 9) and white (from pins 7, 11, & 12) power cable wires. The green wire (chassis) connects to power system ground.

For information on use with any other type of primary mains configuration, contact ETO factory.

Power Cable Connections - The green wire in the main amplifier AC power cable is connected to chassis and must always (and only!) be wired to the AC mains ground (or center neutral with U.S. standard 120-N-120V system). The black and white wires are interchangeable and connect to the two "hot" wires of the service.

Service wiring should be at least #12 AWG copper, protected by fuses or breaker rated at 20 to 30 amperes (#10 AWG, 30 ampere fuses or breaker for PA-77S).

4. Physical Location: The amplifier must be positioned horizontally, and so that the intake of cool air and exhaust of hot air is not impeded in any way, and so that hot exhaust air cannot significantly recirculate back into the cool air intake area. A minimum of six inches clearance should be allowed behind the amplifier, with open access to surrounding air unless special ducting provisions are provided.

Figure 1: Standard TS-1 wiring for 120V or 120/240V AC mains.

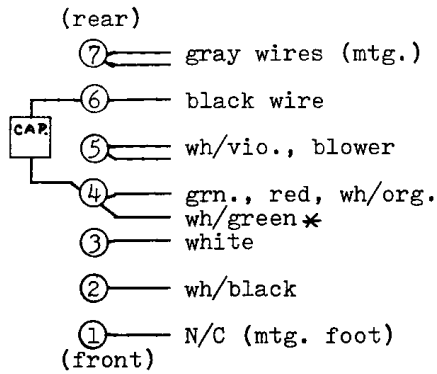

Figure 2: TS-1 wiring modified for 240V without center neutral.  
(See also Figure 4.)

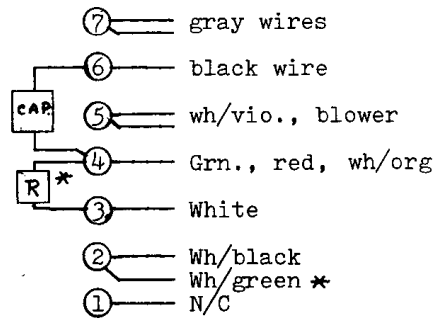

Figure 3: Power cable connector wiring for standard 120/240V service (center neutral).

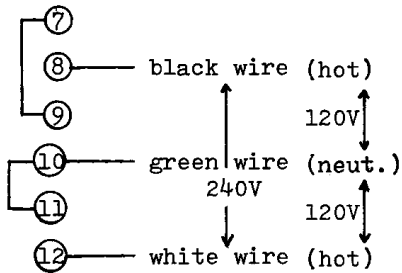

Figure 4: Power cable connector wiring for 240V without center neutral. (See also Figure 2.)

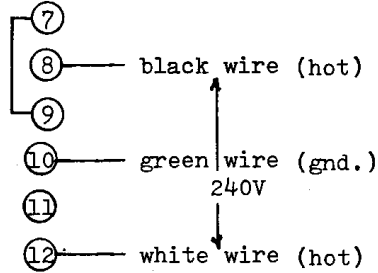
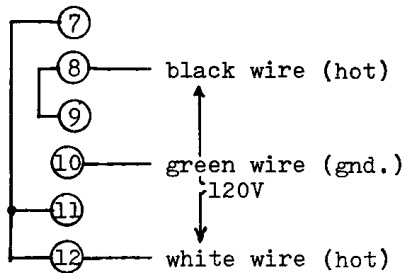

Figure 5: Power cable connector wiring for 120V service.



Scanned by IW1AXR   
  
 Downloaded by   
 Amateur Radio Directory

5. RF And Control Connections: Interconnection of the ALPHA 77Dx (or 77Sx) with any popular transceiver or exciter for conventional PTT, VOX, or manually-controlled T/R operation is straightforward. Special provisions are incorporated for full CW break-in or fast VOX operation with transceivers/exciter so equipped.

Rear panel connections and functions are as follows:

RF INPUT - Use a standard "BNC" plug and RG-58C/U cable to connect to the 'rf output' or 'antenna' jack of the exciter (or transceiver). NOTE: The antenna is fed directly through the amplifier's internal changeover relays back to this RF INPUT jack when the ALPHA is in OFF, STANDBY, or receive conditions, permitting normal reception and exciter-only transmission PROVIDED THAT THE RECEIVER ANTENNA slide switch on the rear of the ALPHA is in its NORMAL (through) POSITION. This arrangement permits the use of conventional transceiver-type rf interconnections, even for CW break-in. (See Figure 7.)

RF OUTPUT - NEVER OPERATE THE AMPLIFIER WITHOUT A PROPERLY MATCHED LOAD CONNECTED TO THIS JACK! Use a standard PL-259 ("UHF"-type) plug and RG-8A/U or equivalent cable for connection to antenna system or dummy load.

RELAY - After the required (3 minute nominal) tube warm-up period has elapsed, a short-circuit placed across this jack will switch the amplifier to the transmit condition, provided the front panel CW or SSB button (not STBY) is depressed. Removing the external short allows the internal changeover relays to return to the receive or "through" condition. The speed of the vacuum relay circuitry in the ALPHA 77Dx (and 77Sx) is sufficient to follow keying at speeds of 50 WPM or more. To protect the vacuum relays from damage due to "hot" rf switching (in all modes), an internal rf interlock circuit prevents them from closing if excitation is already present when the external RELAY control line is closed, and also prevents them from opening - even if the RELAY line is opened up - as long as rf excitation is present.

RECEIVER ANTENNA switch - This slide switch MUST BE IN THE THRU POSITION for operation with conventional transceiver-type connections as described above. In THRU, the antenna will be fed thru to the RF INPUT jack whenever the amplifier is in OFF, STANDBY, or receive, permitting normal reception and exciter-only transmission. In the SEPARATE position, the antenna (or other load) is connected only to the AUXILIARY receiver antenna jack under these conditions. THERE IS THEREFORE NO LOAD CONNECTED TO THE RF INPUT JACK AND STRAIGHT-THROUGH EXCITER OPERATION IS NOT POSSIBLE. (See Fig. 6.)

AUXILIARY receiver antenna - As described above, this jack provides an alternate (and the only) receiver antenna connection when the RECEIVER ANTENNA slide switch is in its SEPARATE position and the amplifier is in OFF, STANDBY, OR receive.

KEY - This ("RCA" or "phono" type) jack may be used to control the CW keying, PTT, or other T/R function of the exciter while insuring proper sequencing of the T/R changeover switching. The ALPHA 77Dx (and 77Sx) provides at this jack an isolated contact



closure which follows the keying imposed externally on the RELAY jack, with one restraint: the output KEY line does not close until the amplifier's internal changeover relay contacts have actually closed. The KEY line opens immediately, however, when the input line to the RELAY jack is opened. When the amplifier is in OFF or STANDBY, the RELAY jack is connected through to the KEY jack.

High speed CW break-in or VOX is available without auxiliary T/R switches and without danger of "hot switching" high power rf -- © PROVIDED THAT THE TRANSCEIVER OR TRANSMITTER-RECEIVER USED IS ITSELF CAPABLE OF BREAK-IN KEYING -- by patching the CW key (or VOX relay contacts) directly into the ALPHA's RELAY jack, and patching the amplifier's KEY jack output back into the exciter key jack (or, for VOX, into the line normally controlled by the VOX relay contacts). (See Figure 8.)

By using the amplifier's AUXILIARY receiver antenna jack to provide the receiver's antenna input, full break-in CW operation is possible with many separate transmitter-receiver combinations that do not themselves incorporate adequate T/R antenna switching for break-in. BECAUSE THERE IS NO EXCITER LOAD CONNECTED UNLESS THE ALPHA 77D<sub>x</sub>(77S<sub>x</sub>) IS IN THE TRANSMIT CONDITION, IT IS ESSENTIAL TO USE THE FULL BREAK-IN KEYING CONNECTIONS (Fig. 8) AND TO BE CERTAIN THAT THE RECEIVER ANTENNA slide switch IS RETURNED TO NORMAL BEFORE ATTEMPTING EXCITER-ONLY OPERATION. (See Fig. 6.)

ALC - ALC may be used with suitably-equipped exciter/transceivers to help maintain excitation at a desired maximum level. A negative-going ALC control voltage appears at the ALC jack when amplifier grid current exceeds a preset value determined by adjustment of the ALC threshold trimmer potentiometer (located near the top of the main plug-in circuit board, CB2, at the rear of the power supply compartment).

This negative-going ALC is compatible with virtually all popular exciter/transceivers using vacuum tube power output stages; some newer all-solid-state transceivers (such as certain Atlas and Ten-Tec models) utilize positive-going ALC, but also incorporate their own adjustable-threshold internal ALC which is suitable for excitation control in lieu of amplifier-generated ALC.

In either event, it is necessary that the ALC threshold control be set to provide the desired amplifier plate current meter swing while the exciter mike gain control is simultaneously adjusted to yield the degree of exciter ALC action specified by the exciter manufacturer. The two adjustments are somewhat interacting, so that several iterative readjustments may be necessary to achieve desired results. EXCESSIVE MIKE GAIN OR ALC SENSITIVITY MAY RESULT IN VERY LOW POWER OUTPUT, ALC "HANG-UP," AND/OR DISTORTION. ©

Figure 6: Simplified ALPHA 77D<sub>x</sub>(77S<sub>x</sub>) Antenna Switching System

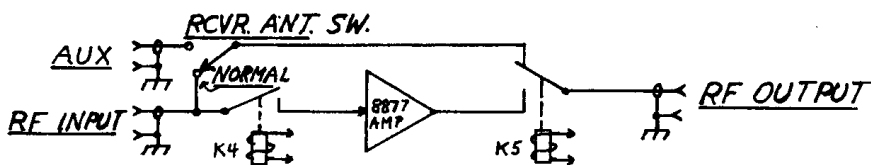



## SECTION 3

### OPERATION

#### 1. Control Functions:

MODE CONTROL PUSH BUTTONS - These four buttons to the right of the AVERAGE PLATE CURRENT meter control AC power on-off and the operational mode of the ALPHA 77Dx(77Sx).

OFF - Push to remove all AC power from amplifier. This button illuminates when all four MODE buttons are out as a result of tripping of the plate overcurrent relay (standard 120/240V wiring).

STBY - Depressing this button applies AC power to the amplifier, illuminating the panel meters and initiating the warm-up delay. When tube warm-up is complete (in 3 minutes, nominal) the STBY button illuminates, signifying READY. As long as the STBY button remains depressed, the amplifier T/R system is locked in receive, permitting straight-thru exciter/transceiver operation PROVIDED that the RECEIVER ANTENNA switch is in NORMAL position.

CW/LOW V - Once the STBY/READY button illuminates, pressing CW/LOW V (always press the MODE buttons firmly and quickly) places the ALPHA 77Dx(77Sx) in operational condition, ready to be controlled by the exciter RELAY line. The CW/LOW V mode is suitable for d-c power input (in any mode) up to 2.5 KW PEP. ALWAYS USE CW/LOW V FOR INITIAL TUNE-UP AND FOR INPUTS OF 1.5 KW PEP OR LESS.

SSB/HIGH V - This mode is intended for operation on SSB and other modes up to the full rated power input (PEP and average d-c) for each mode.

MULTIMETER PUSH BUTTONS - Depressing any of these four buttons switches the MULTIMETER to monitor the parameter shown at the left of the button; full scale deflection is shown at the right of each button. (ALPHA 77Sx EXCEPTION: for the top button, full scale deflection is actually 5A PEAK.) With all four buttons out, the meter reads HV (high voltage), 5 KV full scale. Meter buttons are not illuminated.

In the PLATE/2A PEAK position, the meter indicates approximate d-c plate current reached on recurrent voice peaks; multiplying this value times the HV value at the same time yields an estimate of actual peak envelope power (PEP).

LOAD - Controls plate loading, which is minimum (lightest) near the low-numbered end of the scale and increases clockwise.

- TUNE - Controls the plate tuning (vacuum variable) capacitor. Capacitance is maximum (lower frequency bands) at full counterclockwise rotation and minimum (higher frequency) at full clockwise (see also paragraph 1, page 2).
- BAND - Selects appropriate amplifier tuning range, as indicated (in MHz) on the dial skirt. Band "A" covers 1.8 - 2.0 MHz; Band "B" also covers 1.8-2.0 MHz and offers additional loading.
- ALC - Indicates onset of amplifier ALC action ("threshold") when grid current exceeds preset level.
- AVERAGE PLATE CURRENT - This meter indicates average (or steady state)d-c plate current as required for FCC-defined power input determination. On SSB/voice, average d-c power input is equal to the highest indication of this meter as the pointer swings upward on voice peaks multiplied by the HV indication at the same time: (volts) X (average amperes)= (average d-c power input in watts). (EXCEPTION FOR 77S~~x~~ although meter scale indicates 1.0 amperes full scale, an internal shunt in the ALPHA 77S~~x~~ modifies this to 2.0 amps.)

## 2. Tune-Up Procedure:

- (a) GENERAL - Serious amplifier damage and/or distortion may result unless correct tune-up procedure is followed. @ Adequately-heavy loading adjustment (for the drive level employed) is particularly critical to avoid flattopping, flashover, and possible tube damage. It is essential to be certain that all system bandswitches are set for the same band, and that a matched load for the frequency in use is connected before applying excitation. It is equally essential that excessive excitation (and grid current) be avoided at all times during tune-up and operation. An in-line monitoring oscilloscope is highly recommended as the best means of continuous, instant visual monitoring of operating conditions. @
- (b) METER READINGS - All references in this manual, unless otherwise specified, refer to operation with a steady carrier signal ("key-down"). With a rapidly-varying SSB signal, actual current and power levels are typically two to three times greater than the values indicated by excursions of the meter pointers.
- (c) ALPHA 77S~~x~~TUNE-UP AND METER INDICATIONS - Instructions given herein apply basically to the ALPHA 77D~~x~~; where corresponding values for the ALPHA 77S~~x~~ differ from those for the 77D~~x~~, the "S" figures are shown in parentheses following.

As previously noted, although the panels and meter scales are visually identical, the ALPHA 77S~~x~~ PLATE/2A PEAK MULTIMETER button actually sets up a 5 ampere full scale range, and the AVERAGE PLATE CURRENT meter actually indicates full scale for 2 amperes plate current, or one ampere per tube.

(d) INITIAL TUNE-UP - Insure that the amplifier is properly installed in accordance with Section 2 and that a suitable, matched load is connected.

- (1) Place all four MULTIMETER buttons in the out position by momentarily depressing any button half-way, so that meter indicates HV. Press OFF mode button. Connect AC power cable to primary power.
- (2) Set BAND, TUNE, and LOAD controls to the appropriate preliminary settings shown below for the band in use.  
\*settings determined during lab check-out

<u>BAND (MHz)</u>	<u>TUNE*</u>	<u>LOAD*</u>	<u>TUNE</u>	<u>LOAD</u>	<u>TEST FREQ.(MHz)</u>
"B"	_____	_____	50-60	60	1.8
3-5	_____	_____	118	65	3.8
5-8	_____	_____	155	70	7.2
8-12	_____	_____	160	75	10.0
12-18	_____	_____	165	65	14.2
18-24	_____	_____	180	75	21.3
24-30 (N/A 77DF)			180	80	28.6

NOTE: Near the "TEST FREQ." shown, final control adjustments should be quite close to the above nominal settings, except that LOAD settings may vary substantially if load VSWR significantly exceeds 1:1.

- (3) Press STANDBY while watching MULTIMETER (HV) reading; if pointer does not abruptly rise to 2.2-2.5 KV, immediately press OFF button and determine and correct problem before continuing.
- (4) Leaving the amplifier in STBY, press FWD MULTIMETER button and tune up exciter in accordance with its manufacturer's instructions. Note amplifier MULTIMETER deflection, using upper meter scale for accurate reference (with typical exciters, the deflection will likely be about 0.6 to 1.0 on the upper scale). Press REFL button; if the meter pointer deflection is now lower than on FWD, load VSWR is less than 2:1 (10% reflected power) and hence safe for ALPHA 77Dx(77Sx) operation on that particular frequency. © REPEAT THIS LOAD VSWR CHECK WHEN INITIALLY OPERATING ON DIFFERENT FREQUENCIES OR WITH OTHER LOADS OR ANTENNAS. Correct any load VSWR in excess of 2:1 before using.
- (5) Turn exciter rf output control to zero and return the exciter to receive or standby. Press amplifier GRID and CW/LOW V buttons (IMPORTANT: Always press the mode push-buttons quickly and firmly to avoid transients.) If the CW/LOW V button is not illuminated, wait for it to light when the tube warm-up time delay is complete.

IF AT ANY POINT IN THE FOLLOWING PROCEDURES THE AMPLIFIER DOES NOT RESPOND AS EXPECTED, REMOVE EXCITATION IMMEDIATELY AND CORRECT THE PROBLEM BEFORE CONTINUING:

- (6) Switch exciter to "tune" or "lock key" condition and very slowly increase its output while watching the amplifier GRID and PLATE meter indications. Both should rise off zero with a very low level of rf excitation (less than a watt). Slowly increase excitation until plate current or grid current indication reaches about mid-scale.
- (7) Press FWD button. Carefully adjust first LOAD, then TUNE controls for maximum indication of FWD rf power; repeat until no further increase in power is achievable.
- (8) Press GRID button and note indications of both meters. Desired values for initial tune-up are GRID 0.15 ampere (77Sx - 0.3 ampere) and PLATE 0.45 amp for 77DF (1 KW d-c input @ 2200 typical plate volts for nominal U.S. amateur input power), PLATE 0.6 to 0.7 amp for 77Dx and 77Sx. If PLATE current is lower than desired after step (7), slightly increase excitation and repeat steps (7) and (8). If PLATE current is greater than desired, slightly decrease excitation and repeat (7) and (8).
- (9) When the desired value of PLATE current exists after completion of step (8), initial tune-up is complete. (NOTE that plate current of 0.7 ampere @ approximately 2200 plate volts for government/export 77Dx and 77Sx models, as suggested above, corresponds to d-c plate power inputs of approximately 1500 and 3000 watts, respectively ... since 77Sx actual plate current is twice the meter indication as previously explained.)

### 3. Final Operational Adjustments and Monitoring:

- (a) KEYED CW, FSK/RTTY, SSTV, AØ - At completion of initial tune-up as described above, each model is ready for operation in any of these "carrier" modes at the power level for which it was tuned up. There are no restrictions on "key down" time. It is only necessary to monitor drive power adjustment so that amplifier GRID current remains in the range of 0.1-0.15 ampere for 77DF/77Dx versions and 0.2-0.3 ampere for 77Sx.
- (b) LOW POWER SSB/VOICE - It is possible to operate the amplifier on SSB/voice at PEP power inputs approximately equal to the d-c tune-up powers given in (9) above, by leaving the amplifier in its "CW" position. Simply switch the exciter to SSB and speak normally into the mike while adjusting exciter rf output (usually with mike gain control) until highest swings of the amplifier GRID current meter reach these levels:
  - 77DF/77Dx - 50-100 mA (1/5 scale maximum)
  - 77Sx - 100-200 mA (2/5 scale maximum)AVERAGE d-c power input is the product of highest PLATE meter swings times plate voltage (HV) meter indication at the same moment, and will typically be 35-50% of the initial tune-up input. PEP is about equal to the initial tune-up power.

- (c) HIGH POWER SSB/VOICE - After initial tune-up as described, pressing the amplifier "SSB/HIGH V" button increases plate voltage about 50%, preparing the amplifier for SSB/voice operation at PEP power inputs of approximately 2.0 to 2.5 times the tune-up power level. It is necessary to switch the exciter to SSB and adjust its output exactly as described in the previous paragraph (b) for the specified grid current. Typical power inputs (d-c) will then be approximately:
- 77DF - 1000 watts average (2200V x .45A); 2-2.5 KW PEP
  - 77Dx - 1500 watts average (2150V x .70A); 3-4 KW PEP
  - 77Sx - 2500 watts average (2100V x 1.2A); 5-6 KW PEP

#### 4. Operating Notes:

- (a) 77Dx and 77Sx models may be operated at lower, or in some cases somewhat greater, power levels than outlined above, as long as neither average nor PEP ratings are exceeded. It is important to remember to perform initial tune-up at the input power level desired if actual operation is to be with the amplifier in its "CW/LOW V" mode, follow the procedure in section 2. above except for target plate current. It is entirely feasible to operate either the 77Dx or 77Sx under conditions suggested for the (type-accepted) 77DF, for example.
- (b) For high power SSB/VOICE operation using the amplifier in its "SSB/HIGH V" mode, tune up in the "CW/LOW V" mode at half the d-c plate power input desired under PEP/SSB conditions on "SSB/HIGH V".
- (c) Amplifier GRID current is an extremely sensitive indication of proper excitation level. If grid current swings higher than specified in paragraph (b) above during SSB operation, drive level is excessive for the tune-up conditions that have been established and flattopping (distortion) will result. In this case, either reduce drive power or repeat initial tune-up using a higher level of target plate current (and, hence, drive).
- (d) To avoid distortion (splatter) and possible 8877 tube damage, TOO-HEAVY LOADING (low GRID current) is much to be preferred over TOO-LIGHT loading. Note, however, that sub-normal efficiency and output will result if the actual operating power level (PEP or carrier) is too much lower than the optimum level established during tune-up.
- (e) For unusual types of operation not covered in this manual, contact the CUSTOMER SERVICE MANAGER at the ETO factory for specific information and suggestions.
- (f) Remember that PEP d-c power input cannot be read directly from the standard plate current and plate voltage indications. The product of highest plate current meter swings times the simultaneous plate voltage reading is average d-c plate power input in watts. Actual PEP power input is normally 2 to 2.5 times average. The ALPHA MULTIMETER and its switch provide a "PLATE/2A PEAK" function which indicates approximate repetitive peak d-c plate current. Multiplying this by plate voltage yields a direct indication of approximate repetitive PEP input.

- (g) TUBE RATINGS - The 8877 is extremely rugged and operates with a large safety margin if grid current is never allowed to exceed 0.2 ampere, nor plate current 1.0 ampere, per tube. Also, it is exceedingly important to insure that cooling airflow is never interrupted or blocked. The inevitable consequence of airflow interruption during operation is destruction of the tube.
- (h) INTERLOCKS - Your ALPHA is equipped with switches which shut off a-c power and short the high voltage power supply whenever the cabinet top cover is open. THESE PROTECTIVE INTERLOCKS ARE PROVIDED FOR YOUR PROTECTION AGAINST POTENTIALLY FATAL ELECTRIC SHOCK RESULTING FROM CONTACT WITH LETHAL VOLTAGES INSIDE THE AMPLIFIER. THE AMPLIFIER SHOULD NEVER BE OPERATED WITH COVER REMOVED EXCEPT BY THOROUGHLY KNOWLEDGABLE AND EXPERIENCED SERVICE PERSONNEL!
- (i) FUSES - Except in rare instances of component failure, the blowing of primary line fuses indicates either a severe and sustained overdrive of the amplifier or a major power transient. The latter may occasionally result from slow or incomplete depression of a mode push button (STBY, CW, SSB), resulting in irregular and abnormal operation of the main and step-start power relays. Always press the buttons firmly and quickly to insure smooth changeover of function. The internal step-start protection fuse may be blown by such a switching transient, but application of AC power while the high voltage crowbar switch is shorted (cover open), or by various component failures.

NEVER REPLACE A BLOWN MAIN LINE FUSE WITH OTHER THAN A 250V CERAMIC BODY FUSE OF THE TYPE (3AB or ABC) SUPPLIED, NOR OF A GREATER CURRENT RATING THAN SPECIFIED (20 amperes ALPHA 77D~~x~~ 25 amperes 77S~~x~~). The step-start fuse should be replaced, if necessary, with a similar slow-blow (type MDL or 3AG slo-blo) unit of the original rating -- 77D~~x~~ 2 ampere; 77S~~x~~ 3 ampere.

NEVER REPLACE A BLOWN FUSE UNTIL THE REASON FOR ITS BLOWING HAS BEEN DETERMINED AND CORRECTED.

- (j) PLATE OVERCURRENT RELAY - This solenoid functions primarily to de-energize primary power quickly in the event of a fault in the HV circuitry or grossly excessive drive conditions. Should it trip, popping "out" all mode push-buttons and shutting down the amplifier, it is essential to determine and correct the cause before re-applying power by again depressing one of the mode buttons.
- (k) MAINTENANCE AND TROUBLESHOOTING - Most apparent failures and problems with the ALPHA 77D~~x~~ and 77S~~x~~ result from operators' failure to read and thoroughly understand the contents of this manual, as well as basic linear amplifier principles - rather than from actual equipment defects.

Most actual equipment defects can be traced to problems with tubes, fuses, loose connectors or AC wiring externally, or circuitry located on plug-in circuit board CB2.



The amplifier interior, particularly the high voltage d-c areas of the power supply and rf compartment, should be cleaned frequently enough (with a soft brush and a vacuum cleaner) to prevent visible accumulation of dust. If extremely dusty conditions prevail, it may be advisable to secure across the air intake area a thin plastic air filter, of the type commonly used in window air conditioners.

#### TROUBLESHOOTING HINTS

<u>SYMPTOMS</u> Ⓞ	<u>POSSIBLE CAUSE/CURE</u> Ⓞ
1. Completely inoperative; no meter illumination or HV indication.	a) External breaker, fuse, or AC wiring open or missing. b) Cover interlock open. c) Fuse F1, F2, or F3.
2. Power relay clicks and blower may start, but low or no HV and no meter illumination.	a) Step-start relay K2 not closing; defective F3, +24V supply or regulator, HV fault. b) One primary line breaker or one fuse (F2) open; step-start resistor R1 or R2 open.
3. Meters illuminate and HV indication normal, but will not switch to transmit condition.	a) Time delay not complete (is READY, LOW V, or HIGH V button illuminated, whichever is "in"?) b) Amplifier in STBY mode. c) External RELAY jack wiring. d) Exciter rf/relay sequencing.
4. Amplifier draws plate current (up to 150 ma) and slight grid current at all times. Otherwise operates normally.	a) Bias switching transistor Q202 damaged (or driver Q203).
5. Amplifier draws plate and grid current when exciter is keyed, but will not load properly, no rf output to load.	a) Input T/R relay K4 broken. b) Output T/R vacuum relay K5 damaged. NOTE: If K4 is shorted, amplifier will draw grid & plate current (when exciter keyed) even if in STBY mode.
6. Low or no grid current with drive, low power output, abnormal VSWR seen by exciter.	a) Damaged rf sensor (D3-D4 area), or bias switch transistors Q202 or Q203 (open).
7. Amplifier draws plate current, as soon as warmed up, in excess of 0.2 ampere with zero drive; can be driven but meter readings may not be normal.	a) Short or partial short on cathode bias line; C203, C204, D17, etc.; 8877 tube cathode leakage.
8. Amplifier draws plate current (typically over 0.2 amp.) with zero drive; can not be driven, high VSWR seen by exciter.	a) 8877 tube cathode shorted to grid or heater; may be intermittent, with short sometimes clearing itself temporarily.

- 9. RF flashover (usually between loading capacitor plates) in rf compartment.
  - a) Excessive load VSWR; mismatched or wrong antenna; defective rf cables; antenna breaking down.
  - b) Antenna relay K5 damaged.
  - c) Capacitor plates damaged by repeated arcing as above.
  
- 10. DC flashover in rf compartment, usually with sharp snap or bang.
  - a) Dirt and/or grease accumulation in HV d-c areas, especially on outer surfaces of ceramic transmitting capacitors used for bypass and coupling in plate ckt.
  
- 11. Low drive and output power; cannot drive exciter to normal input or output levels.
  - a) ALC sensitivity (threshold) control (R212 on CB2) set improperly; unplug ALC line to check.
  
- 12. Distortion on SSB output signal; possibly severe TVI.
  - a) Excessive drive power and/or insufficiently-heavy loading.
  - b) Flashover of antenna, feedline, or variable capacitor on peaks.
  - c) RF feedback from antenna or feedline into exciter or mike.

## SECTION 4

### THEORY OF OPERATION

1. 8877 RF Amplifier Circuitry: (Refer to Fig. 18) The 8877 triode tube (two, parallel-connected, in ALPHA 77S) is connected in grounded-grid for high stability, linearity, and simplicity. Bandswitch S2 and associated components provide pre-tuned input circuits to optimize performance on each amateur band from 160 through 15 meters (or other frequency ranges if appropriately readjusted). Switch S1 permits disconnecting the input tuning network for operation across the amplifier's entire tuning range without input network adjustments. (S1 is located adjacent to the tube socket on the top of the tube deck; move its button toward the rear of the chassis for untuned input.) \*10M 77Dx/Sx.

The output (plate matching) network is a full pi-L, providing excellent harmonic suppression and operating efficiency across the entire tuning range. Use of a vacuum variable tuning capacitor combined with silver plated inductor L4, of heavy copper tubing, enhances efficiency on the highest frequency bands. Multiply-insulated toroidal inductors L5 and L7 maintain very low losses combined with compactness and freedom from unwanted cross-coupling on 3-5 MHz and 1.8-2.0 MHz. Toroid L6 and inductor L10 provide the necessary "L" inductance.

Power reed relay K4 and vacuum relay K5 perform antenna change-over switching at speeds sufficiently high to follow CW keying at 50 WPM or more, and operate silently. Toroid L16 and associated components constitute an rf wattmeter directional coupler. Separate low-level rf detectors are provided, one on either side of input relay contacts K4, to provide control signals for operation of the electronic bias switch and QSK system. D1-D2 and related components are the "pre-K4" detector and D3-D4 the "post-K4" detector.

Also required for operation of the QSK system, the transmit (N.O.) contacts of antenna relay K5 are isolated by rf chokes L14 and L15 plus feed-thru capacitor C30, to provide a d-c path at C3 which indicates closing of K5's contacts. Series diodes D5-D7 provide a leakage path to ground via L14, protecting the "L" network and antenna circuitry against electrostatic charge buildup or breakdown of C20-C21; at the same time, the forward voltage drop of D5-D7 is sufficient to permit the QSK circuitry to distinguish between the "open" and "closed" states of K5.

2. Power Supply and Control: (Refer to Figs. 19 & 20) Main AC power relay K1 operates off rectified AC line voltage, controlled by push button MODE switch S5 and cover interlock S9. Step-start resistors R1 and R2 limit the initial current inrush at turn-on to 12 amperes maximum; as HV filter capacitor C reaches full charge, all operating voltages approach normal and step-start relay K2 closes to short out R1 and R2. In the event of a fault which prevents K2 from closing, step-start fuse F3 protects R1 and R2 from damage. (F3 is located on the main chassis immediately behind the power transformer and to the left of K3.)

Transformer T1 provides all a-c voltages required for operation of the amplifier. High voltage tap-change relay K3, controlled by S5, selects either of two high voltage secondary taps, yielding d-c operating high voltage of approximately 2500 V or 3900 V at no load. Full wave bridge rectifier D13-D16 and oil-filled HV filter capacitor C39 complete the basic HV supply. Resistor R8 limits the maximum surge current that can flow in the event of a high voltage fault (such as an internal tube flashover), thereby protecting both amplifier and tube against damage. The voltage drop across R8 is sampled via R5 (and peak-limited by zener diode D19) for control of the plate overcurrent relay located on plug-in board CB2. In the event of a high voltage fault to ground, D17 will provide a low-impedance return path to B-, protecting the bias system against damage. (The series combination of D17 is necessary because the normal operating voltage at this point varies from +60V to -10V.) Precision resistors R10-R14 provide for metering of high voltage, and bleeder resistors R6 and R7 discharge the filter capacitor after power turn-off, for safety reasons. High voltage shorting crowbar switch S6 prevents accidental personnel contact with high voltages by grounding the HV line when the top cover is opened. AC interlock S9 removes primary power immediately when the cover is opened even slightly.

Cooling blower B1 is provided with reduced operating voltage of approximately 75 V by the use of a 50 V transformer winding, "bucking" connected; resistor R4 permits adjustment of blower speed over a substantial range. (An advantage of using the 50 V bucking winding rather than simply operating the blower from a 75 V transformer winding is that blower speed tends to increase slightly under extremely heavy load conditions, rather than slowing as transformer voltage drops slightly.)

If excessive plate current (and hence voltage drop across R8) actuates the plate overcurrent sensing relay on CB2, front panel solenoid K7 is in turn energized, mechanically pulling the release mechanism of MODE switch S5 and thereby turning off AC power to the amplifier. Restoring power (after the cause of the fault has been corrected) requires only pressing the desired MODE button again.

The illuminated-type buttons of the MODE switch are also used as status indicators. Upon completion of the required warm-up time delay, +24 V is fed to the front panel via pin 2 of connector P5; this voltage is switched by S5a, S5c, and S5e so that the STBY/READY, CW/LOW V, or SSE/HIGH V button will light. The OFF/RESET button lights when all four buttons are out, with AC power applied and the cover interlock S9 closed, except that this feature is not operative with 2-wire 240V a-c input.

3. Low Voltage and Miscellaneous Circuits (except QSK): (Fig. 21)  
The larger plug-in circuit board, CB2, contains low voltage d-c supplies, time delay, electronic bias switch, ALC, and peak plate current metering circuits, as well as the plate overcurrent - sensing reed relay.

The +24V DC Supply consists of rectifier D214, filter capacitor C211, and integrated circuit voltage regulator MC7824. Capacitor C208 insures regulator stability, and C209 improves output regulation under transient load conditions (as when switching K3).

The 8877 tube receives cathode bias from the +50 V supply consisting of D215 and C212. Bias is applied via R207, and is sufficient to cut off plate current flow under standby conditions. When the amplifier T/R relays are actuated, pin 17 is externally switched to ground and resistor R208 pulls the cathode bias voltage down to approximately 15 V, which allows a very slight idling plate current to flow. In the presence of 100 milliwatts or more of rf excitation at the "post-K4 rf detector," bias switch transistor Q202 is switched fully on, reducing tube bias to the nominal +8.1 V established by zener diode D206, as follows: (a) the rectified and filtered rf from the rf detector cuts off driver transistor Q203, which is otherwise biased into conduction by R210; (b) this permits current via R209 to turn Q202 fully on, effectively grounding the anode of D206.

Amplifier grid current (only) flows through Q202 and R211; the small drop across R211 is measured by the multimeter via R214, providing front-panel GRID current monitoring.

The voltage drop across R211 caused by grid current flow is also used to actuate the ALC generator via threshold-adjust trimpot R212. Q204 functions as a d-c inverter, providing a negative-slope output from the positive-slope grid current input off R211. Q205 is an emitter follower which provides relatively low ALC output impedance; zener D208 provides necessary offset so that ALC output begins at zero and goes negative. Negative d-c operating voltage for the ALC emitter follower is provided by rectifier D213 and filter C210, regulated to -18 V by zener D212.

Q206, driven in parallel with ALC inverter Q204, drives the red front panel LED which indicates onset of ALC action. The level of grid current at which ALC (and LED) action thresholds is set by adjusting R212.

Unijunction-type transistor Q207 is used in a timing configuration to establish the tube warm-up time delay of nominally 180 seconds. Until Q207 conducts, firing Q208 and closing the relay K202, no +24 is applied to the bias switch or T/R relay circuits, and the amplifier is locked in the STANDBY condition. Upon initial power turn-on, timing capacitor C207 begins charging through R222; the PUT Q207 provides an extremely high load impedance for R222-C207, permitting a long time constant to be achieved easily. After approximately 180 seconds the voltage across C207 is sufficient to cause Q207 to close relay K202, putting the amplifier in the READY condition by routing +24V to the bias switch and T/R relay circuits. K202 latches closed via Q208.

An approximate indication of peak plate current is generated by a dual time constant "hang" type circuit and an emitter follower. Plate current returns from B- to cathode via R203 and R204. A voltage proportional to the peak current value is stored with a long time constant established by C202 and the high input (base) resistance of Q201 - an emitter follower which drives the meter.

A somewhat higher voltage (the drop across both R203 and R204 in series) is stored with a shorter time constant established by C201/R205. When plate current drops to a lower level, the voltage across C202 remains relatively constant at its peak value until C201 discharges to a voltage slightly lower than that across C202, at which point C202 also begins discharging through D202 and R205 at a relatively rapid rate. Thus, the highest level of voltage to which C202 charges on plate current peaks is "held" long enough to permit the mechanical multimeter (driven by Q201 in the peak plate current position of the meter switch) to respond; after a short "hold" period (approximately 0.2 seconds in practice), C202 is rapidly "dumped" through D202 and becomes ready to respond to the next major plate current peak.

Plate overcurrent sensing relay K201 is located on CB2 for mounting convenience. Voltage drop across fault-current-limiting resistor R8 is reduced by a voltage divider consisting of R5 (on the HV rectifier board in the power supply) and R206 in parallel with the coil of K201, on CB2. Zener diode D19 on the HV board protects the relay coil against extreme voltage surges during HV faults. When K201 closes, its contacts switch 120 VAC to the plate overcurrent trip solenoid K7 (on the front panel), via rectifier D2, disengaging MODE switch S5.

4. CW Break-In (QSK) System: (Fig. 22) The basic operation of the QSK system is best understood by considering the sequence of events which occurs when a pair of contacts (a CW key, PTT, or other contacts) connected to the amplifier RELAY jack is first closed, then opened. (Amplifier in CW/LOW V or SSB/HIGH V)
- (a) Immediately upon closure of the RELAY line contacts, Q303 is turned 'off,' allowing the relay driver transistor Q301 to be switched 'on' by base current via R307 PROVIDED that Q302 is NOT switched 'on' at the time.
  - (b) Q302 will be 'off' IF (1) the amplifier is in the OPERATE condition (not STBY) so that +24V from the MODE switch via QSK board (CB3) pin 10 turns Q307 'on,' preventing turn-on of Q302 via R302, D304, and R301, AND (2) Q304 is conducting, thereby preventing turn-on of Q302 via R303; Q304 is normally biased 'on' via R308, but will be switched 'off' by negative voltage from the "pre-K4 RF sensor" via CB3 pin 6 and R309 if detectable excitation power is present at the amplifier RF INPUT jack when the RELAY line is initially closed. Note that this sequence is only operational when the T/R relays are in the 'receive' (de-energized) condition, since - upon turn-on of Q301 to energize the relays - the d-c voltage at Q301's collector drops to nearly zero and consequently no bias-on voltage for Q302 or Q304 is available via D304. Thus, Q304 serves only to inhibit T/R relay closing when excitation is already present and Q307 inhibits relay closing when the amplifier is in STANDBY; once the T/R relays are energized, Q302, Q304, and Q307 are inactive.
  - (c) Exciter-keying relay K302 cannot be actuated by Q306 until Q305 turns 'off.' Q305 is normally biased 'on' by two separate sources: (1) via R306 and R310, a source which goes to

zero when the key contacts (RELAY line) are closed, and (2) via R311. The bias supplied via R311 is shorted to ground via the N.O. (transmit-side) contacts of main T/R relay K5 when they close; the path is via pin 7 of CB3, chassis harness wiring and feed-thru capacitor C3 to the rf deck area, and finally via L13, L14, the contacts of K5, and through L15 to ground. Thus the exciter-keying relay is energized only when both \*the external RELAY line is closed and \*the main T/R vacuum relay transmit contacts have actually closed. (It should be mentioned that it is unnecessary to sense K4's contacts because they close somewhat more quickly than K5's, and also that the inherent contact 'bounce' characteristics of K5 are excellent so that any bounce has ended by the time K302 closes and keys the exciter 'on.' Also, R301-C301 constitute a "hot-shot" network which accelerates the closing of K5.)

The complete T/R "make" sequence, then, delays closing the exciter KEY circuit (via pin 9 of CB3) only as long as is required for the main vacuum T/R relay (K5) contacts to close, provided that the amplifier is in an operate condition and no excitation is already present when the RELAY line is closed (by key contacts, PTT switch, etc.) NO arbitrary time delays are introduced by the QSK system, and keying speed is limited only by closing time of K5 (typically 1.0 millisecond) and of K302 (typically less than 0.5 msec).

- (d) When the key (or other contacts on the RELAY input line) is opened, Q305 instantly conducts and cuts off Q306, causing exciter-keying relay K302 to open typically within 0.5 msec. Negative bias from 'post K4 rf sensor' via pin 5 of CB3 prevents Q303 from turning 'on' (and thus cutting 'off' Q301 and releasing the main T/R relays to 'receive') until actual rf output from the exciter drops below the rf sensor's threshold of approximately 100 milliwatts. Once that occurs, the T/R line is de-energized as Q301 cuts off, and the system is in its original 'key-up' condition.

The overall function of the QSK system is thus such that keying speed is limited only by the capability of the main T/R vacuum relay and the 'break' shaping of the exciter keying characteristic, yet proper sequencing of keying functions is assured and it is virtually impossible to "hot switch" the T/R relays. Full break-in keying is possible to speeds in excess of 50 WPM. © ©

**IMPORTANT NOTE:** The contacts of exciter-keying reed relay K302 are protected against electrical damage by a protective network consisting of R316-C306 and R317. On rare occasions an exciter or transceiver may be encountered which will not key entirely properly with 100 ohms (R317) in the key line; in such a case, CB3 may be unplugged and R317 changed to a lower value resistance. The greatest value which permits normal exciter keying should be used, and not less than 47 ohms unless absolutely necessary.

Relay K301 switches the amplifier RELAY jack directly through to the KEY jack when the ALPHA 77D (77S) is OFF or in STANDBY.

SECTION 5 — ILLUSTRATIONS

FIGURE 9 - FRONT PANEL

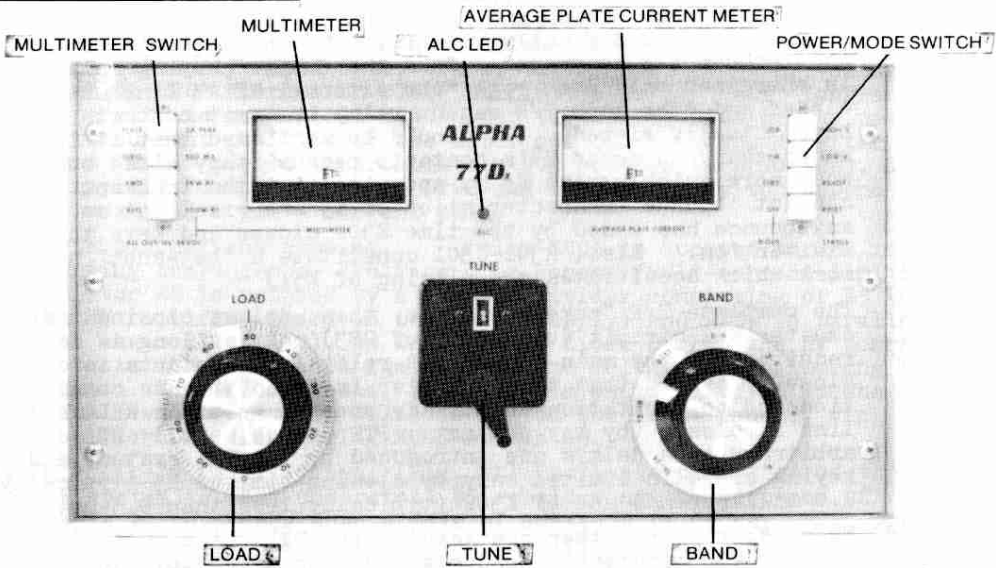
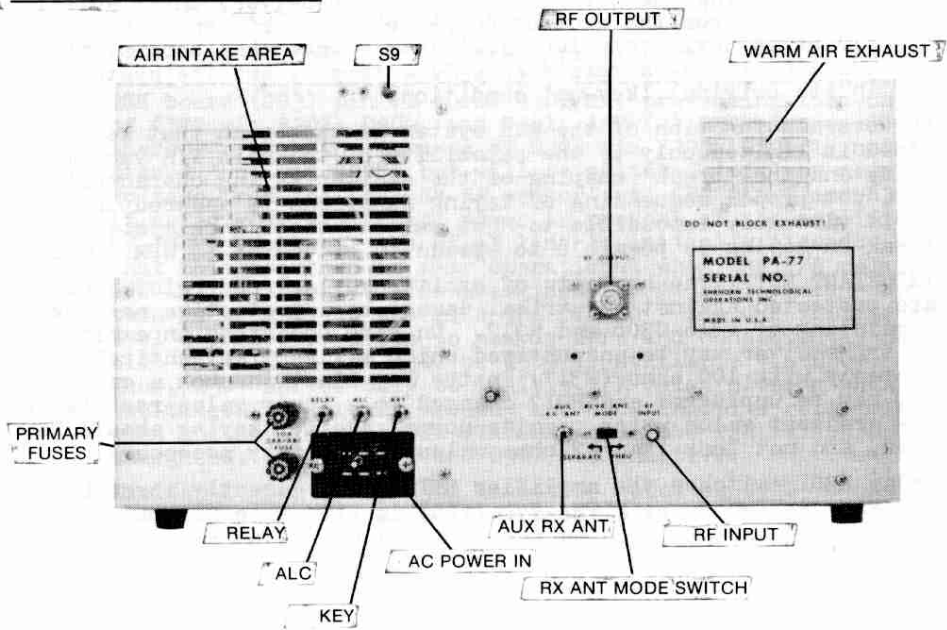

FIGURE 10 - BACK PANEL



Scanned by IW1AXR  
 Downloaded by  
 Amateur Radio Directory



**FIGURE 11 - Front Sub-Panel (Main Front Panel Removed)**

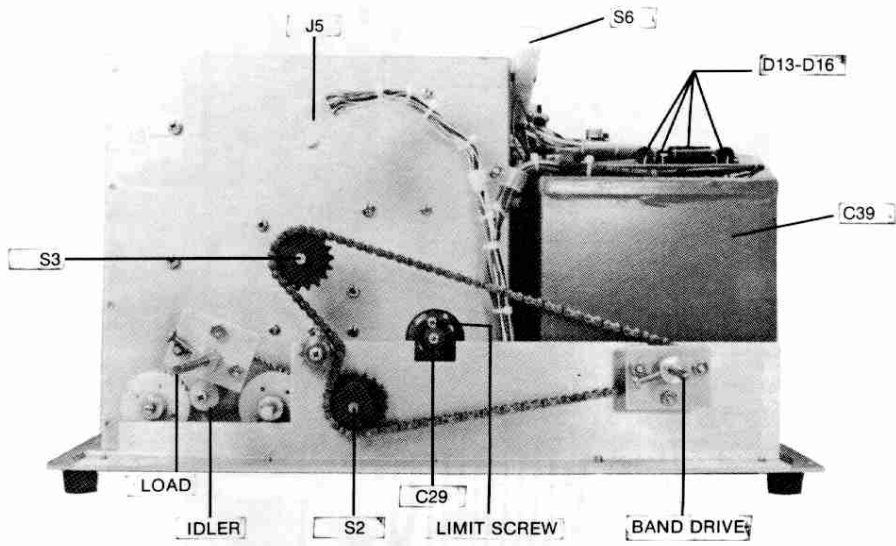

**FIGURE 12 - Back View of Front Panel**

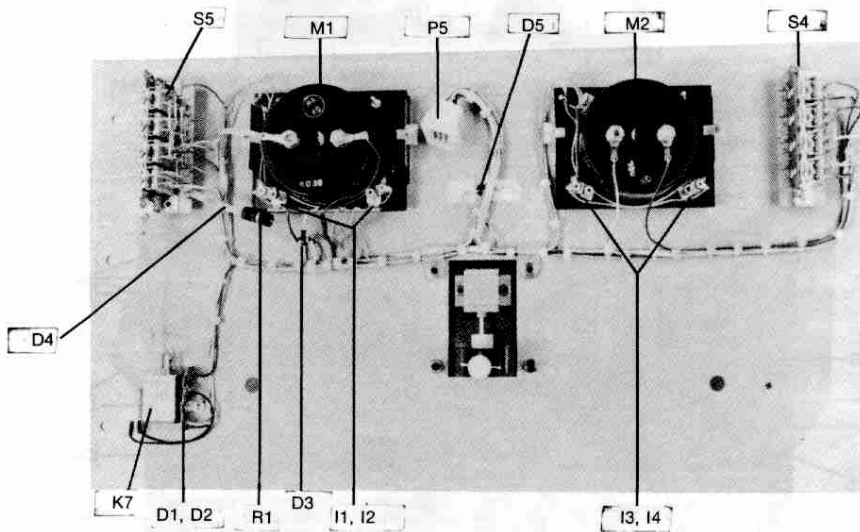

Scanned by IW1AXR



Downloaded by  
Amateur Radio Directory

**FIGURE 13 - Top View RF Compartment (Cabinet Cover, Inner RF Shield, and Hot Air Exhaust Duct Removed)**

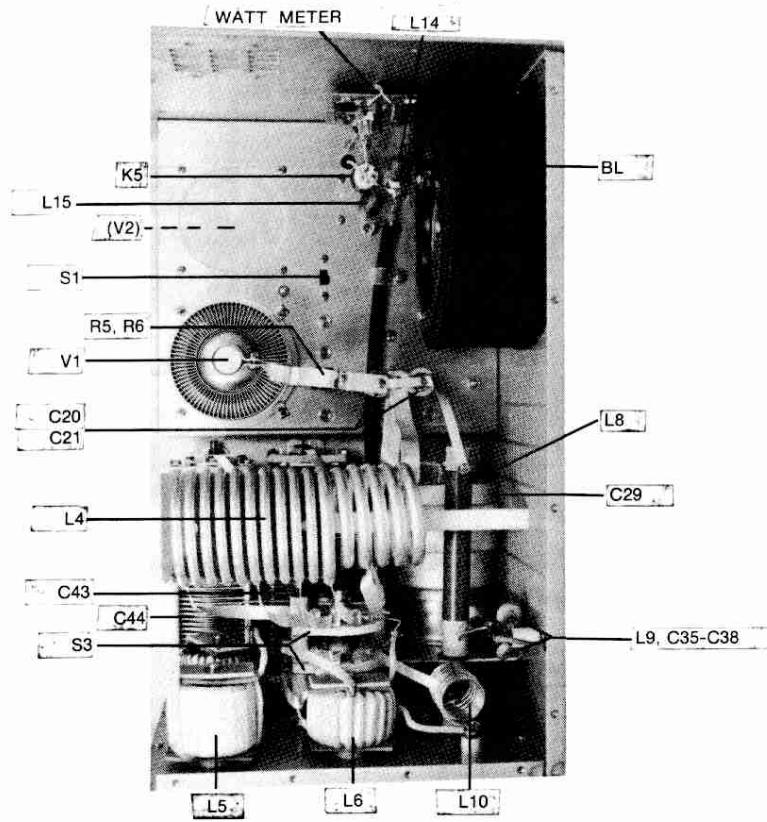

**FIGURE 14 - Side View RF Compartment (RF Side Shield Removed)**

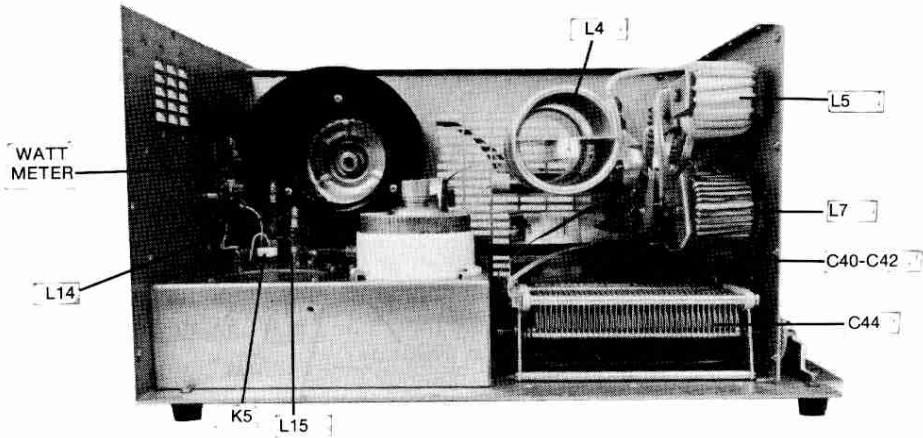

**FIGURE 15A - Power Supply Side View (T1 Transformer Removed)**

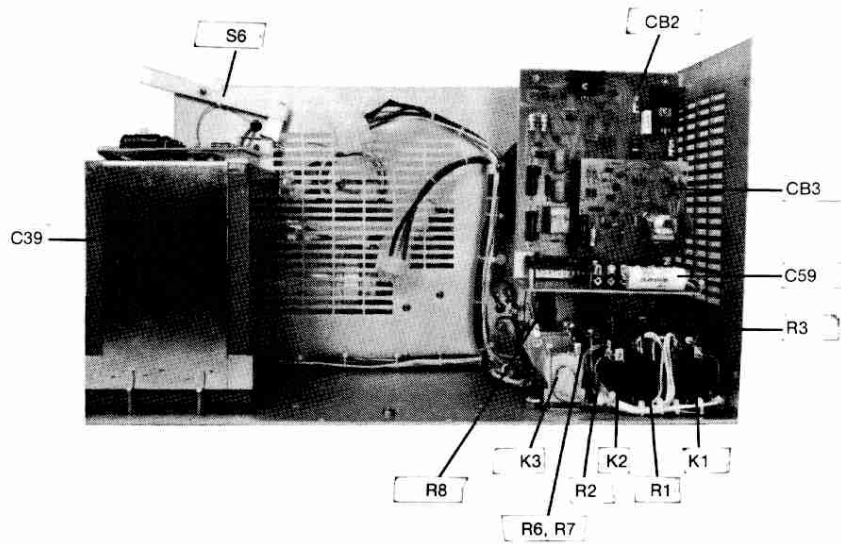

**FIGURE 15B - Power Supply Oblique View**

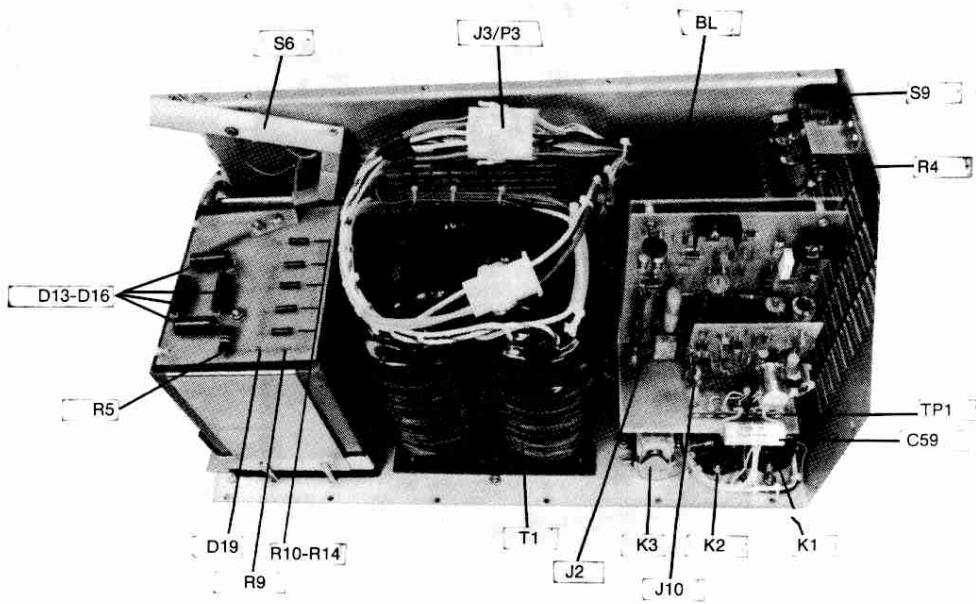

FIGURE 16 - Underside of Tube Deck (Cover Plate Removed)

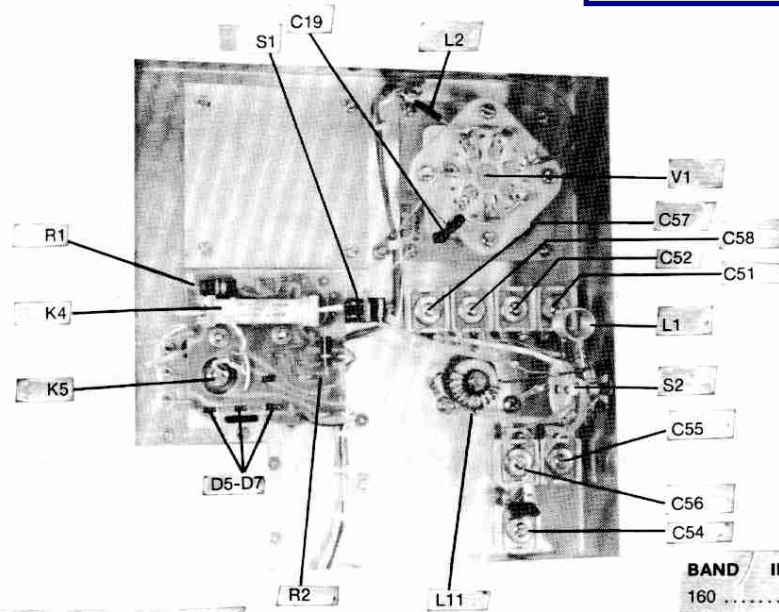
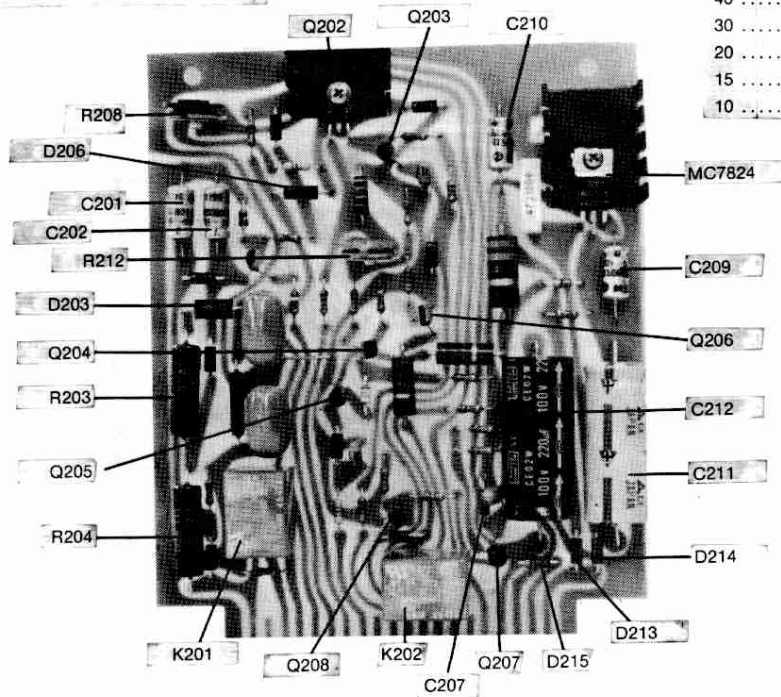
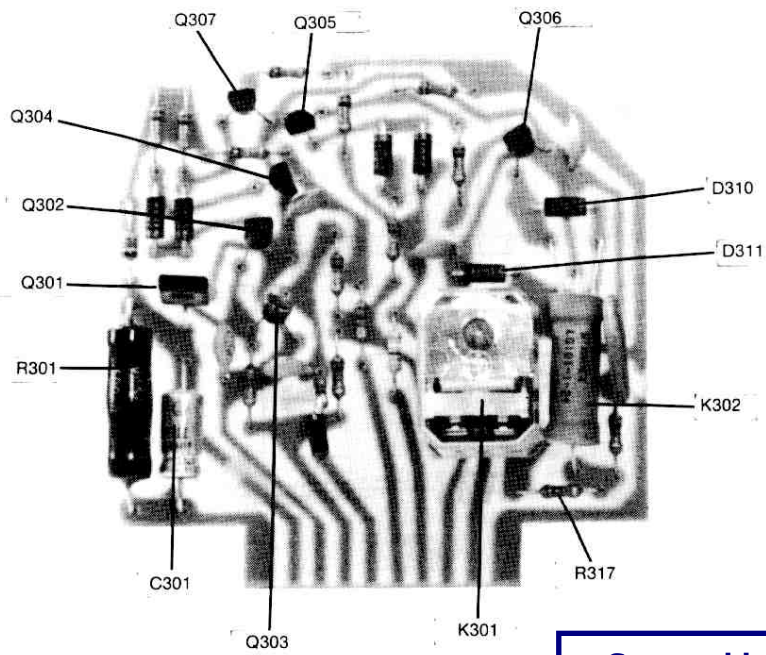

FIGURE 17 - Circuit Board CB2



BAND	INPUT CAP.
160	C53/C54
80	C56
40	C55
30	C57
20	C58
15	C52
10	C51

**CIRCUIT BOARD CB3**



Scanned by IW1AXR  
Downloaded by  
Amateur Radio Directory

**WATTMETER CIRCUIT BOARD**

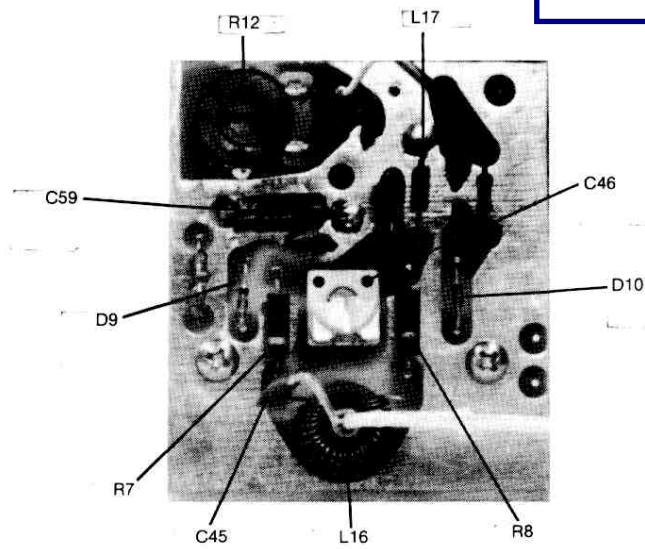

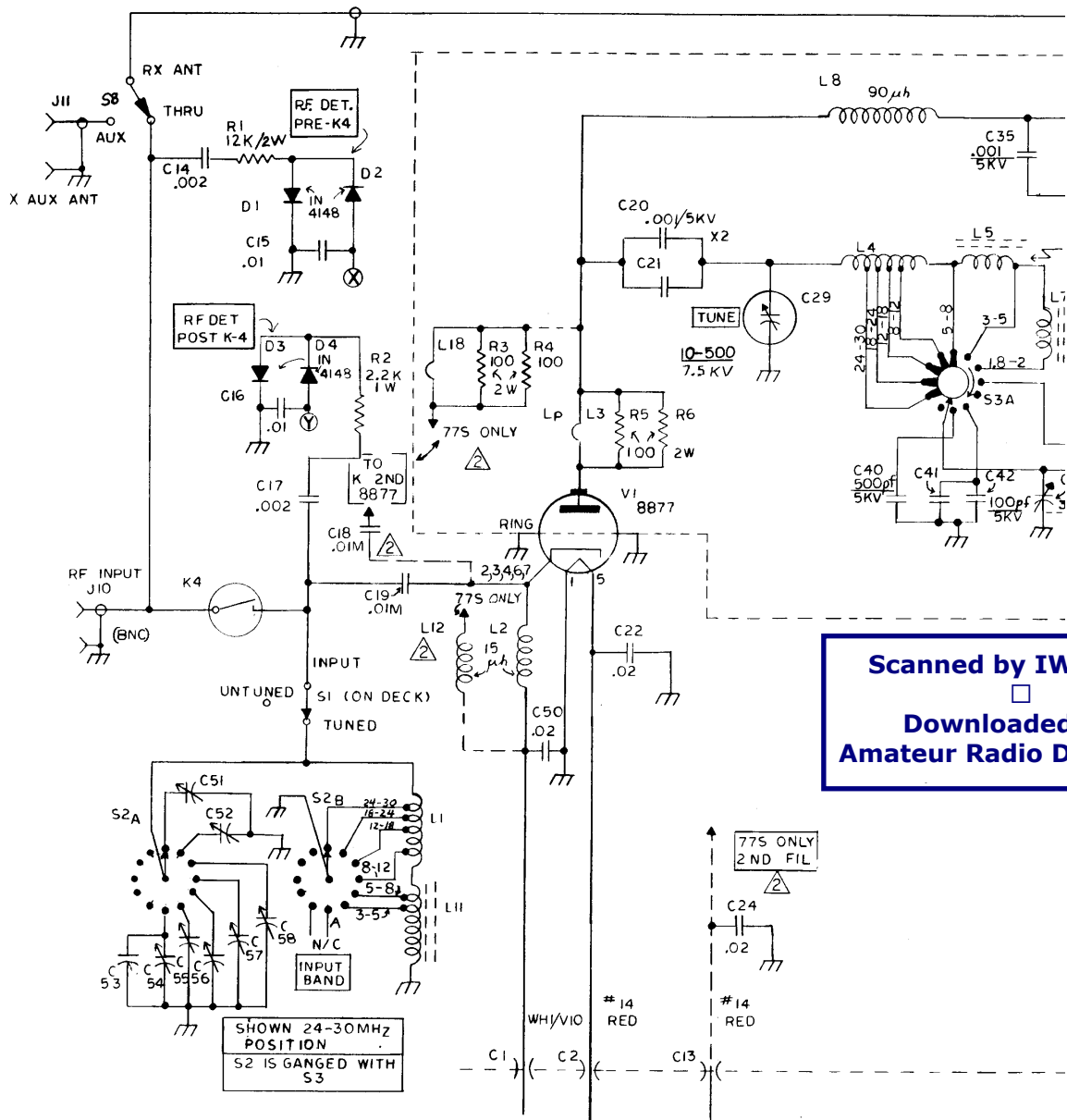

1. ALL RESISTORS ARE 5OR 10%
2. ALL  $\text{---} \parallel \text{---}$  FT ARE 1500 pF

- $\triangle$  T\*STAT DELETED IN S/N 2751 AND ABOVE
- $\triangle$  C18 C24 C25 L12 L18 R3 R4 T2 V2 IN 775 ONLY

FIG

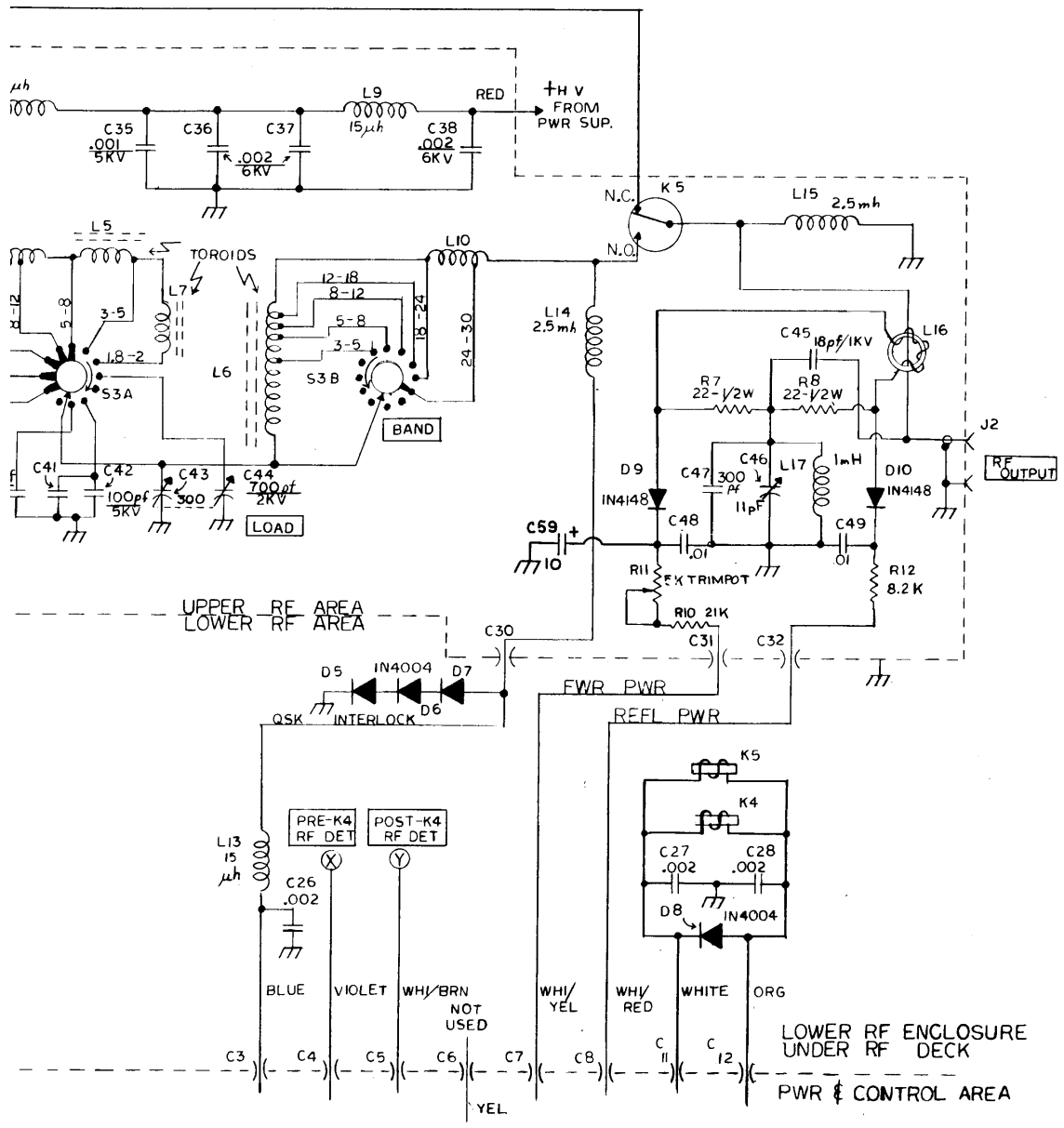
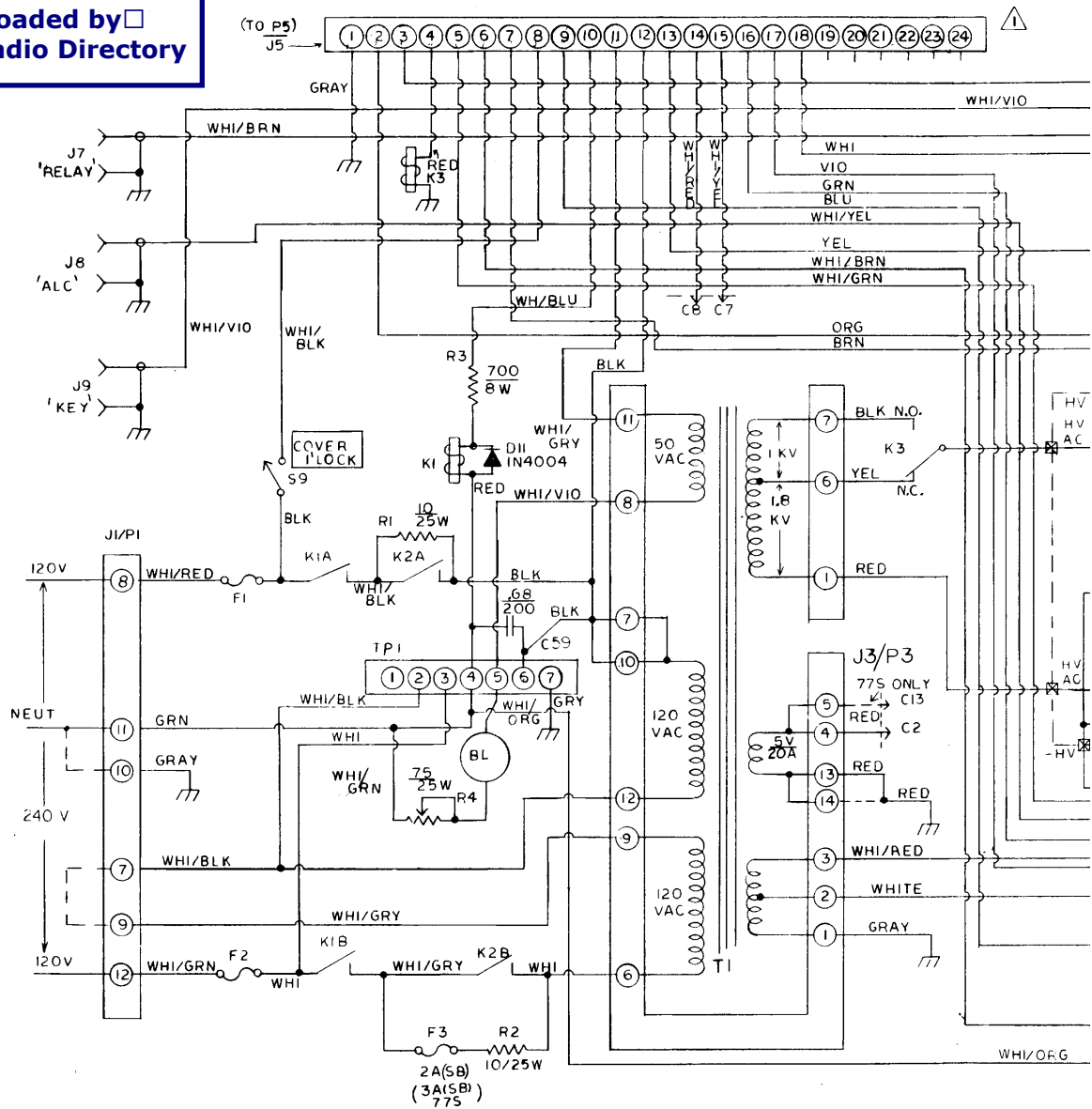

FIG. 10: ALPHA 77D & 77S SCHEMATIC - RF SECTION

EHRHORN TECHNOLOGICAL OPERATIONS, INC.  
 CAÑON CITY, CO. 81212 REV: 5-77

Scanned by IW1AXR  
 Downloaded by  
 Amateur Radio Directory



⚠ PINS 14 THRU 19 MAYBE PINS 1 THRU 6 OF J6  
 IN OLDER MODELS

FIG 19: ALPHA  
 EHRHORN



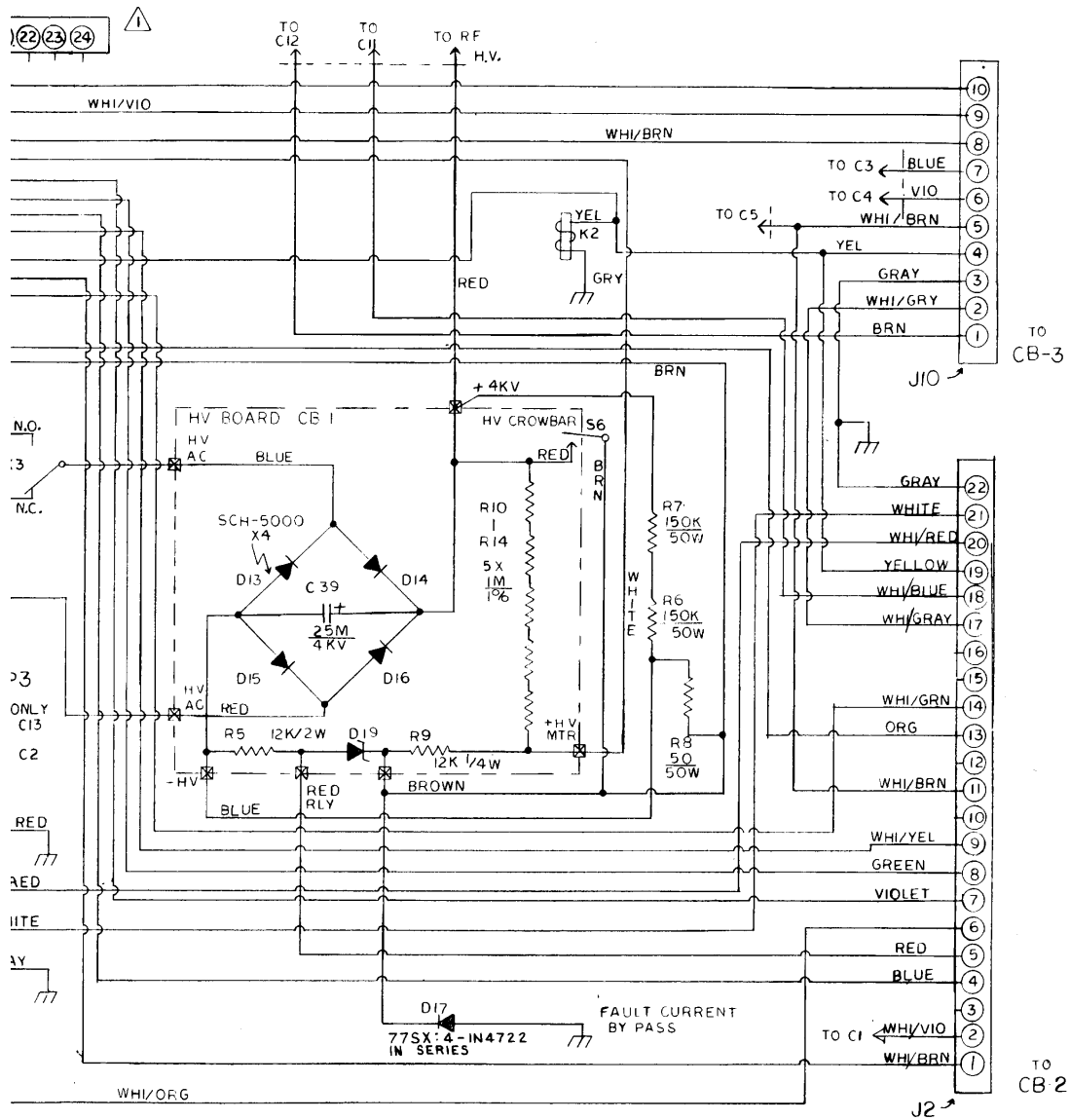
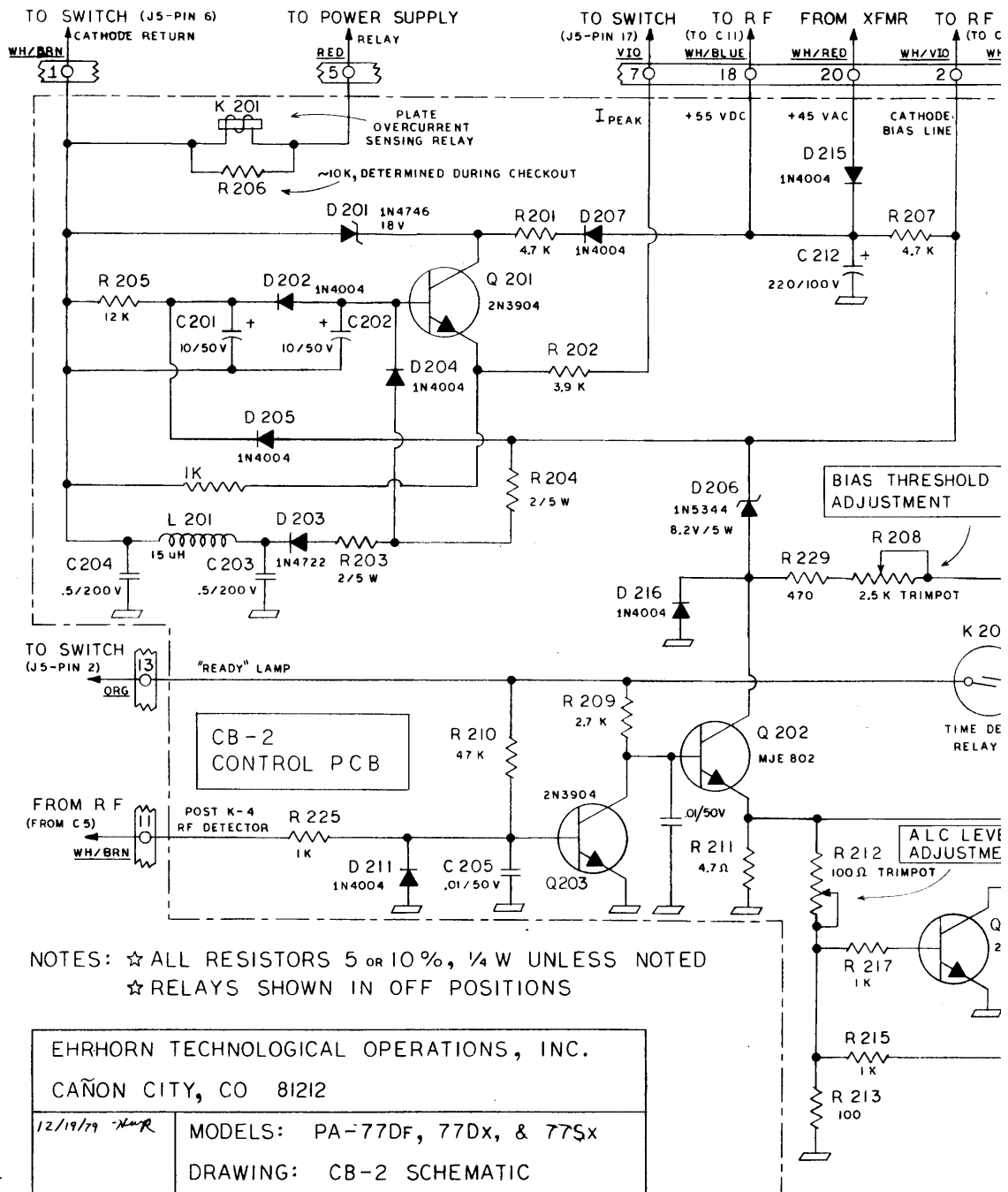

FIG 19: ALPHA 77D & 77S SCHEMATIC - POWER SUPPLY & MAIN CHASSIS

EHRHORN TECH. OP'NS, INC. CAÑON CITY, CO. 81212 REV: 5-77







Scanned by IW1AXR  
 Downloaded by  
 Amateur Radio Directory

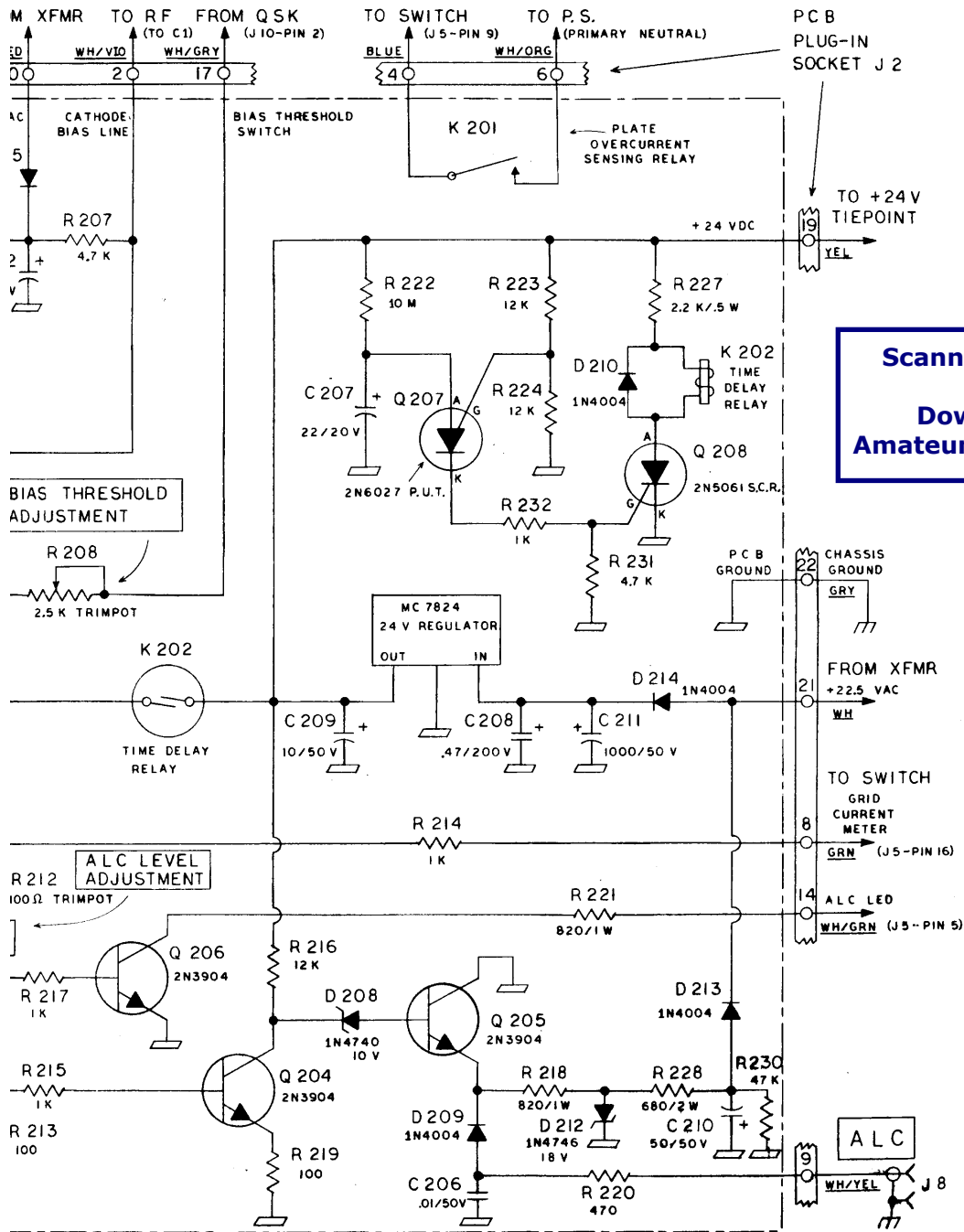

Scanned by IW1AXR

Downloaded by Amateur Radio Directory

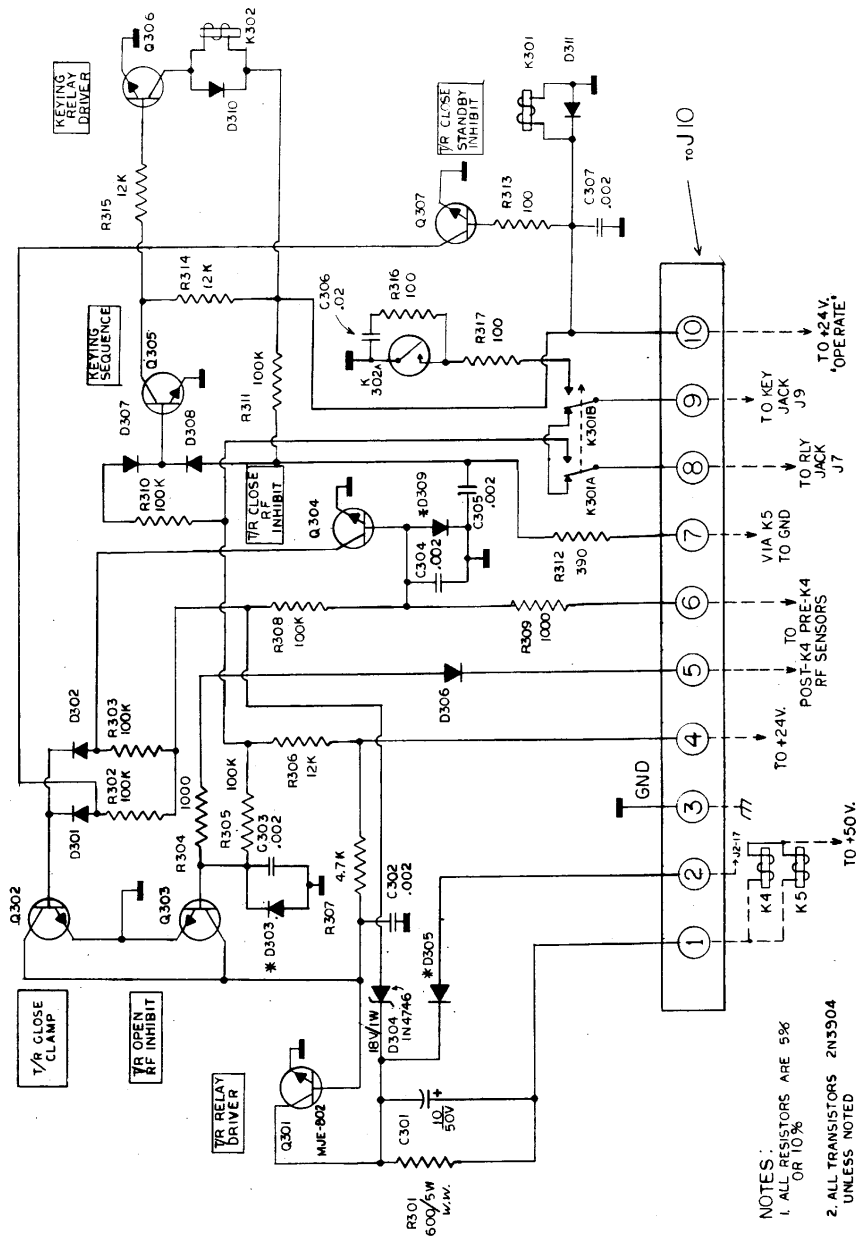

- NOTES:
1. ALL RESISTORS ARE 5% OR 10% UNLESS NOTED
  2. ALL TRANSISTORS 2N3504 UNLESS NOTED
  3. ALL D'S ARE 1N4004 UNLESS NOTED
  4. ALL CAPACITORS IN  $\mu\text{F}$  UNLESS NOTED
- \* COMPONENT MAY BE MOUNTED ON FOIL SIDE.

FIG. 22: ALPHA 77D & 77S SCHEMATIC - CB3 (QSK BOARD)  
 EHRHORN TECHNOLOGICAL OPERATIONS, INC.  
 CANON CITY, CO. 81212 REV: 5-77

SECTION 6 - STANDARD ELECTRICAL PARTS

<u>SYMBOL</u>	<u>DESCRIPTION</u>	<u>SYMBOL</u>	<u>DESCRIPTION</u>
<u>RF SECTION (Fig. 18)</u>		<u>(POWER SUPPLY/CHASSIS CONT'D)</u>	
C1-C13, C30-C34	CRL FT1500 feed-thru	J1	Cinch-Jones S406CCT (on power cable)
C14,C17,C26-C28	.002uf/1KV disc cer.	K1,K2	Aromat HL2 DC24V
C15,C16,C48,C49	.01uf/50V disc cer.	K3	Magnecraft type no. W158-HVX-1-24V
C18,C19	.01uf/500V dip mica	R1,R2	10/25W wirewound
C20,C21,C35	.001uf/5KV (858S)	R3	700/8W wirewound
C22-C25,C50	.02uf/500V disc cer.	R4	75/25W adjustable w.w.
C36-C38	.002uf/6KV disc cer.	R5	12K/2W 10% comp.
C40	500pf/5KV (850S)	R6,R7	150K or 200K/50W w.w.
C41,C42	100pf/5KV (858S)	R8	50/50W wirewound
C45	18pf/1KV	R9	12K/1/4W 5% film or c.c.
C46	11pf trimmer	R10-R14	1Meg, 1% type RN65D
C47	300pf dipped mica	S9	Microswitch 17AC1T or equivalent interlock
C51-C58	Spcl. mod ARCO 300M	<u>FRONT PANEL (Fig. 20)</u>	
C59	10uf/25V electrolytic	D1-D4	1N4004
D1-D4,D9,D10	1N4148 or 1N914B	D5	Red LED MLED650 or eq.
D5-D8	1N4004	I1-I4	Type 334 lamp, 28V
K4	Magnecraft W102RMX7	I5-I8	Type 387 lamp, 28V
K5	Kilovac HC-1/ITTRJ1A	K7	Size 24 solenoid, 24VDC
L2,L9,L12,L13	15uh,1A choke	M1	0-1.0 amp d-c, special
L14,L15	1-2.5mh, 300 ma RFC	M2	0-1.0 ma d-c, special
R1	12K/2W carbon comp.	R1	1.5K/2W 10% c.c.
R2	2.2K/1W carbon comp.	R2,R3	77S only: 2/3W wirewnd.
R3-R6	100/2W 10% A-B hot molded carbon	S4,S5	Switchcraft 67041K-506
R7,R8	22/1/2W 10% comp.	<u>CIRCUIT BOARD CB2 (Fig.21)</u>	
R9	8.2K/1/4W 5% film/c.c.	K201,202	Guardian 1575-1C-24D
R10	21K/1/4W 5% film/c.c.	L201	15 uh, 1A choke
R11	5K tripot	<u>CIRCUIT BOARD CB3 (Fig. 22)</u>	
R12	8.2K/1/4W 5% film/c.c.	K301	Potter-Brumfield type R10-E2-Y2-V700
V1 (&V2, '77S)	Eimac 8877 triode	K302	EAC type 1A24AH (24V)
<u>POWER SUPPLY/CHASSIS (Fig. 19)</u>		<u>CIRCUIT BOARD CB2 (Fig.21)</u>	
BL	Rotron VS37A2-R1	<u>CIRCUIT BOARD CB3 (Fig. 22)</u>	
C39	25uf/4KV oil filled	K201,202 Guardian 1575-1C-24D	
C59	0.68uf/400V film	L201 15 uh, 1A choke	
D11,D12	1N4004	<u>CIRCUIT BOARD CB3 (Fig. 22)</u>	
D13-D16	5000PIV/0.5A CCS, Semtech #SCH-5000	K301 Potter-Brumfield type R10-E2-Y2-V700	
D17	1N4722 (400PIV/3A)	K302 EAC type 1A24AH (24V)	
D19	1N4757 (51V/1W)		
F1,F2	77D: 20A/250V #3AB 77S: 25A/250V #3AB		
F3	77D: 2A MDL slo-blo 77S: 3A MDL slo-blo		



## ETO/"ALPHA" PRODUCTS WARRANTY

### EHRHORN TECHNOLOGICAL OPERATIONS, INC. (ETO) WARRANTS AS FOLLOWS EACH NEW ELECTRONIC PRODUCT OF ITS MANUFACTURE:

- (1) Workmanship and all components except rf power tubes are guaranteed for TWO YEARS from date of original purchase if used exclusively in licensed amateur radio service, and for ninety days in non-amateur service. WARRANTY IS VOIDED BY ILLEGAL SALE OR USE OF EQUIPMENT (e.g., U.S. sale of export models).
- (2) Power tubes are warranted by their manufacturer; ETO will assist owners in securing warranty service if requested.
- (3) Warranty does not apply to repair of damage resulting from improper maintenance or repair, misuse, neglect, abuse, or improper installation, nor to units not operated in accordance with specifications and instructions furnished by ETO, nor to units repaired or altered by persons not authorized by ETO, nor in cases where the serial number has been removed, altered, or defaced.
- (4) If a malfunction is suspected, before attempting repairs or returning equipment to ETO for service the owner shall contact selling dealer or factory service department, providing model and serial numbers plus details of equipment hook-up, accessory equipment used, operating conditions, and abnormalities observed. ETO will furnish a new part in exchange for any covered defective part or, if it is determined that factory service is required, will authorize return to factory. Equipment authorized for return shall be shipped fully prepaid and insured via United Parcel or air freight (to Colorado Springs airport only), using only FACTORY APPROVED PACKING; REMOVE POWER TRANSFORMER BEFORE SHIPPING ANY UNIT WHICH WAS ORIGINALLY SHIPPED FROM THE FACTORY WITH TRANSFORMER REMOVED!
- (5) In order to receive warranty service, owner must have returned a completed warranty registration form to ETO within 15 days of original purchase, or must provide proof of purchase date when requesting service. Warranty will be transferred to subsequent owner provided he notifies ETO in writing of his name, address, date of purchase, and the equipment model and serial.
- (6) No person is authorized to assume for ETO any liability, other than as set forth in this warranty, in connection with our products. ETO reserves the right to change its products as it deems desirable, without obligating itself to make such changes available for previously manufactured products.

(UNDER PROVISIONS OF THE FEDERAL MAGNUSON-MOSS WARRANTY ACT, THIS WARRANTY POLICY IS CLASSIFIED AS A LIMITED WARRANTY.)

#### **EHRHORN TECHNOLOGICAL OPERATIONS, INC.**

4975 North 30th Street  
Colorado Springs, Colorado 80919 U.S.A.  
(719) 260-1191

1/90