

MODEL
99

Operating Manual



Alpha 99
Power Amplifier

ALPHA POWER PRODUCTS

ALPHA 99
Operating Manual

Warnings posted in this manual should be read and thoroughly understood by users. Failure to perform procedures properly may result in amplifier damage, fire hazard, or electric shock.

© Radio Alpha Products Inc.
6185 Arapahoe Road • Boulder, CO 80303
Phone 303.473.9232 • Fax 303.473.9660

DISCLAIMER

Information in this document is subject to change without notice. Information provided by Radio Alpha Products Inc.® is believed to be correct and reliable. However, no responsibility is assumed by Radio Alpha Products Inc., unless otherwise expressly taken. Companies, names, and data used as examples are fictitious, unless otherwise noted.

No part of this document may be reproduced or transmitted in any form or by any means, graphic, electronic, or mechanical, for any purpose without the express permission of Radio Alpha Products, Inc. Radio Alpha Products, Inc. may have patents or pending patents, trademarks copyrights, or other property rights covering the subject matter in this document. The furnishing of this document does not give you license to these patents, trademarks, copyrights, or other intellectual property, except as expressly written in any license agreement form.

Radio Alpha Products Inc.

6185 Arapahoe Road

Boulder, CO 80303-1401 USA

Read this entire manual and all other publications pertaining to the work to be performed before you install, operate, or maintain this equipment. Practice all product safety instructions and precautions. Radio Alpha Products, Inc. provides information on its products and associated hazards, but it assumes no responsibility for the after-sale operation of the equipment or the safety practices of the Owner or User. See Warranty and Notices Appendix.

©Copyright 2002 by Radio Alpha Products Inc.

All rights reserved.

Table of Contents

Introduction	7
General Description of the ALPHA 99 Amplifier	7
Equipment Shipped	7
Safety: Installation and Operation	7
Specifications, ALPHA 99	9
Before Installing Your Alpha 99	11
AC power Source	12
Antenna	12
Coax and Connectors	13
Air Flow	13
RF Safety	13
Before Operating Your Alpha 99	14
Figure 1 - Top View	15
Carefully unpack amplifier and transformer.	17
AC Primary Connections & Amplifier Grounding.	17
Install the transformer.	17
AC Primary Connections & Amplifier Grounding	18
Power Cord Connections	19
RF Grounding	20
Replacing the Amplifier Cover	20
Internal Blower/Auxiliary Fan	20
Amplifier/Station Interconnections	22
Coaxial Cable Types & Connectors	22
T/R Control Cable	22
ALC	22
Figure 5 - Alpha 99 Rear panel	23
Control Functions	24
Turning on the amplifier:	26
Table 1 - Preliminary Tuneup Settings	28
Tubes	30
Interlocks	30

Fuses	31
Plate Overcurrent Relay	31
Idling Plate Current And Electronic Bias Control (Ebs)	31
RF & Mistuning Protection	31
Preventive Maintenance	33
Figure 6 – Simplified Chassis Schematic	38
Figure 7- Display Board ABX-X400	39
Figure 8 – Control Board ABX-X401	40
Figure 9 – Control Board ABX-X401	41
Figure 10 – T/R Status Board, Multimeter Switch and Switch Matrix Board	42
Figure 11 – Power Supply Board	43
Figure 12 – HV Filter and Screen Supply Board	44
Figure 13 – T/R Status Board and Multimeter Switch	45
Figure 14 – Output Wattmeter Board	46
Figure 15 – Center Partition Board	47
Figure 16 – Tube Deck BCX-X413	48
Figure 17 – Wiring Harness	49
ALPHA PRODUCTS WARRANTY	50

IMPORTANT!

Critical precaution during installation of your Alpha 99:

While the cover is removed to install the power transformer, make sure that the tubes are properly installed as described in Section 2. Failure to do this may cause severe damage or destruction of both tubes. Such damage is not covered under warranty.

Introduction

General Description of the ALPHA 99 Amplifier

The ALPHA 99 is a self-contained HF Linear power amplifier capable of continuous operation at 1500 watts peak power output on SSB, keyed CW, SSTV, RTTY, digital modes or FM, with no time limit. If periods of “continuous-key-down” carrier operation will exceed 5 minutes, or if the amplifier is to be operated from 50 Hz AC source, the optional auxiliary cooling fan available from Radio Alpha Products must be installed to avoid possible damage not covered by the warranty.

Owner Assistance

Assistance is available from Alpha Power Customer Support at 303.473.9232 x.. 141, or by fax at 303.473.9660, or by email at alpha-service@RadioAlphaProductsinc.com.

Equipment Shipped

The Alpha 99 amplifier ships in two cardboard cartons. One carton holds the power transformer and weighs 43 pounds; the second carton contains the amplifier and weighs 38 pounds.

Safety: Installation and Operation

The Alpha 99 amplifier is designed to meet international safety standards and FCC regulations. However, one should always remember that **the equipment works with high voltages that are LETHAL!**

This operating manual holds information, cautions and warnings that must be followed to ensure safe installation and operation. Read Section 1 before attempting to unpack or operate the amplifier.

Warnings: What Not to Do

- Never open the amplifier case without unplugging the unit from the wall outlet.
- Never stick objects into holes in the case.
- Never touch an antenna during transmission.
- Never attempt to turn on the amplifier without the cover in place.
- Never turn the amplifier back on after a hard fault without waiting at least 20 seconds.
- Always resist the temptation to immediately hit the ON button after the amplifier faults to power off.

Warnings posted in this manual should be read and thoroughly understood by users. Failure to perform procedures properly may result in amplifier damage, fire hazard, or electric shock.

Specifications, ALPHA 99

Frequency Coverage:	All amateur bands 1.8-29.7 MHz* plus most non-amateur frequencies 6.0-19.0 MHz and 20.0-30.0 MHz.
Power Output:	1500 watts peak all modes, including SSB, CW and continuous or modulated carrier. Carrier operation (e.g., A0, RTTY or FM) for more than 5 minutes at or near maximum rated power requires use of the auxiliary cooling fan accessory.)
Drive Power:	50 to 60 watts nominal for rated output.
Power Gain:	Nominally 14 dB, a power increase of 25 times.
Input Impedance:	50 ohms nominal, unbalanced; VSWR <1.5:1.
Output Impedance:	50 ohms unbalanced.
Maximum Load VSWR:	2:1 at full rated power output.
VSWR Trip:	Automatic standby when reflected power >250 watts.
Intermodulation Distortion:	30 dB below rated output.
Harmonic Output:	<-60 dBc.
Tubes:	Two Svetlana 4CX800 ceramic-metal tetrodes.
Cooling:	Full-cabinet, ducted forced air using cushion-mounted centrifugal blower.
Automatic Level Control (ALC):	Negative from 0, adjustable.
Primary Power:	190-250 or 90-130 VAC nominal, 50-60 Hz, fused at 20 amperes.
Power Transformer:	3+ kVA with strip-wound Hipersil core.

Protective Functions:	Grid and screen current limiting; trip to standby (automatic reset) for excessive VSWR or average plate current, RF arc, severe mistuning; AC off trip for HV fault; primary and step-start fuses; cover AC interlock and HV crowbar switches; AC inrush-current limiting (Step-start).
Status Indicators:	STANDBY, WAIT (initial turn-on time delay), OPERATE and FAULT LEDs.
Metering:	Dedicated, full-time LED bargraphs display forward and reflected rf power; grid current LEDs; LED bargraph selectable among plate voltage, plate current, and tune-up functions.
Size:	7.5" H x 17" W x 16.5" D (19x43x39cm) excluding controls, feet, and connectors.
Weight:	66lb. (30kg) net, 75lb (34kg) ship; two cartons.

Note: Radio Alpha Products reserves the right to change design and/or specifications without prior notice or obligation.

*FCC rules do not permit new amateur amplifiers to be operable on 24-30 MHz as delivered within the United States and possessions. The Alpha 99 as shipped to any US address will not be operable on 21 MHz and above. Owners who send a copy of their authorizing license to Radio Alpha Products will be provided information on "unlocking" these bands.

WARNING –READ THE MANUAL CAREFULLY BEFORE INSTALLING YOUR ALPHA 99.

The ALPHA 99 is extremely easy to install, but failure to carry out each procedure exactly as described in the manual is likely to lead to amplifier damage which is not covered under warranty. Damage to other station equipment also may result.

Before Installing Your Alpha 99

1. Be careful not to twist or warp the chassis when handling the amplifier with its cover removed. Never lift the chassis by a corner, especially when the transformer is in place. Never apply AC power without the transformer properly and fully installed.
 2. **When installing or removing the transformer**, move carefully and follow the instructions in this manual exactly. Insure that all connectors are properly mated and fully seated. Don't force them! Tuck the lifting handle out of the way so that the interlock can close.
 3. Ensure that both tubes are solidly seated in their sockets with the red silicone rubber chimneys firmly seated against the chassis. The delrin posts over the tubes are to keep the tubes from shifting during transit, they can be removed but should be replaced if the amplifier is to be shipped.
 4. Connect the green conductor in the ALPHA 99 power cord only to the power source neutral or ground. **Connecting the green wire to a "hot" line is almost certain to cause immediate damage. Triple check your wiring before plugging in!**
 5. Make sure the primary power tap is connected to the tap closest to your actual AC voltage. See Manual Section 3. You should measure your line voltage with a digital meter for accuracy.
 6. **Solidly ground all station equipment together.** Heavy braid, such as the outer conductor of RG-8/U coaxial cable, is recommended for the purpose. This is important for personal and equipment safety as well as to avoid feedback.
 7. **Never install cover screws longer than 1/4".** Longer screws may penetrate internal boards or wiring and cause severe damage. Make sure each screw hole in the cover is aligned with its corresponding captive nut in the chassis before inserting screws.
 8. Remove the fan retaining screws before operating the amplifier, the screws can interfere with fan operation.
-

Station Engineering Considerations

The 99 is capable of dramatically improving the performance of your amateur station. It is important that you observe good engineering practices to achieve all the benefits of such a station in a safe and reliable manner. This section provides a few hints for important operational considerations, but it is recommended that the user also consult a good source of general information such as “The Radio Amateur’s Handbook” by the ARRL, especially if this is the first high-power amplifier you have used.

AC power Source

If you do not have a 220V AC outlet in your shack, you will need to get a licensed electrical contractor to install one. A minimum of a 20 amp capacity is required. A 20 amp breaker on your 220V circuit is sufficient. For this reason, the amplifier is not shipped with a power plug. Select a location for the outlet as close as possible to where you expect to operate the 99. If you are not sure, or contemplate moving the amplifier, it may be cheaper to get a second outlet installed at the same time. Ask your contractor for two or three matching plugs while he is there, as there are several styles of connector available. Ask the contractor to measure the voltage and record it, so you can set the line voltage tap on the 99 appropriately. If he can, ask him to tell you the line voltage with a 10 Amp current draw, and use this value for setting the transformer tap. The Alpha 99 can run on a 110V AC outlet. However, you WILL NOT achieve full legal limit output in this case. If the amplifier is connected to a 110V AC outlet, you should not expect more than 1000 watts output.

Antenna

Many antennas which are suitable for general use are unsuited for operation with a full 1500 watts of power. At this power level in a 50 ohm circuit, the RMS current is 5.5 amps and the peak RF voltage is 387 volts. With a 2:1 SWR, these values double to 11 amps and 775 volts. The voltage and current at various points in or on your antenna can actually be many times these values. On a simple dipole with sharp wire ends, corona (localized ionization) can easily occur. Corona can (and has!) lead to fire in nearby objects. Traps in beams and verticals can heat up significantly during high power operation. Instances of melting or flashover of traps have occurred in many installations where insufficient thought has been given to their ratings. If an antenna has been deployed for a long period of time, it may be worth taking it down for inspection prior to full power operation. If any insulators are cracked or show signs of “tracking”, replace them. Doubling-up on insulators is also easy to do, and may save problems. If there is any chance of people or objects coming close to the antenna, take steps to move it higher, or place barriers so that this cannot happen. Check the SWR of your antenna. If you have a favorite part of any band you use most often, consider adjusting the antenna for minimum SWR in this part of the band.

Coax and Connectors

The importance of a well constructed feedline system cannot be overstated. After all, the purpose of the amplifier is to provide approximately 2 S units (12+ dB) of improvement in your radiated signal. All too often, installations are encountered where cheap/poor/under-rated/old coax and connectors are probably responsible for at least one S unit of degradation. This means you could have bought a 375 Watt amplifier and achieved the same radiated signal by buying good quality feedline components! Use the lowest loss 50 ohm coaxial cable you can get your hands on. Use new, clean connectors installed per the manufacturer's recommendations. Clean the connectors after soldering them, and before mating them with the amplifier. Make sure any excess solder is removed from the connector, likewise any fragments of braid etc. Never use old coax, which may have had moisture penetrate under the jacket. Run the coax in straight lines as much as possible. Support it frequently using non-compressive clips so that it does not hang or stretch under its own weight. Avoid sharp bends (most manufacturers will specify a minimum bend radius for their product). Make sure the transition from feedline to antenna is waterproof. Provide for disconnection of the feedline when not in use.

Air Flow

It is critical that the 99 air flow is unrestricted in any way. Keep the top of the amplifier clear of any restrictions. If you are mounting the amplifier in a console, make sure that the exhaust air is properly and fully removed from the console. Poorly designed consoles can result in outlet air being drawn back into the amplifier air intake and recirculated, getting hotter and hotter, resulting in degraded amplifier performance or even failure. If you are designing your own console, consider putting in additional fans and/or ducting to deal with waste heat. Try to minimize the possibility of dust or other contamination getting drawn into or falling on the amplifier. It is also advisable to periodically clean the dust out of your amplifier for continued flawless operation.

RF Safety

The FCC requires users to check their installations for compliance with published values for allowable exposure to RF fields. This information is available in ARRL publications, FCC printed rules, and on the web. Radio Alpha Products strongly recommends that this be done for any installation, both fixed and at an expedition or contest site.

If you have any questions regarding engineering your 99 into your amateur radio station, do not hesitate to call Radio Alpha Products Alpha Technical Support.

WARNING –READ THE MANUAL CAREFULLY BEFORE OPERATING YOUR ALPHA 99.

The ALPHA 99 is extremely easy to operate, but failure to carry out each procedure exactly as described in the manual is likely to lead to amplifier damage which is not covered under warranty. Damage to other station equipment also may result.

Before Operating Your Alpha 99

1. You must set transceiver power output properly. Virtually all damage to date has resulted directly from severe overdrive. The ALPHA 99 requires about 50 watts drive for full rated output. **Damage caused by applying several times rated drive power to the ALPHA 99 will not be covered under warranty.** Fortunately, most modern transceivers maintain quite consistent output from band to band and mode to mode if set up properly.

Setting only the transceiver POWER or RF PWR control IS NOT SUFFICIENT. Several popular transceivers can generate RF spikes of 200-300W or more unless the transceiver's internal ALC (drive level) is also adjusted carefully according to its manufacturer's instructions. This typically is done with a knob labeled DRIVE (IC-781, FT-1000) or PROCESSOR OUT (TS-940, TS-950). On SSB, when speech processing is not, adjust the MIC or MIKE controls.

2. **The ALPHA 99 “faults” into STBY or OFF when unsafe operating conditions occur.** If this occurs, the fault will clear after 30 seconds and if you are certain that you have taken care of the problem that caused the fault, you may turn the amplifier back to operate and proceed with use.
 3. **On any frequency where your antenna VSWR exceeds 1.5:1,** it's important to carefully tune the ALPHA 99 for a proper match. The Alpha 99 does not contain an antenna tuner. The SWR will need to be tuned via the antenna or an external tuner connected to the output of the Alpha 99.
 4. If you tune the amplifier for maximum power output and then decide to operate the ALPHA at power output much different from 1.5kW, it must be re-tuned for efficient and RF-clean operation.
 5. Induced energy from nearby electrical storms or other power transients may damage components. **Such damage is not covered under warranty.** It is important to use a
-

good lightning arrestor, and it's good practice to disconnect and ground antenna feedlines, and to disconnect AC power, when the equipment is not in use.

6. Never use an automatic antenna tuner into or through the 99. This will cause damage to the Input Wattmeter & Input Relay. Note that many popular transceivers have built in antenna tuners which should be disengaged when driving your amplifier.

HAPPY AND SAFE OPERATING.

Figure 1 - Top View

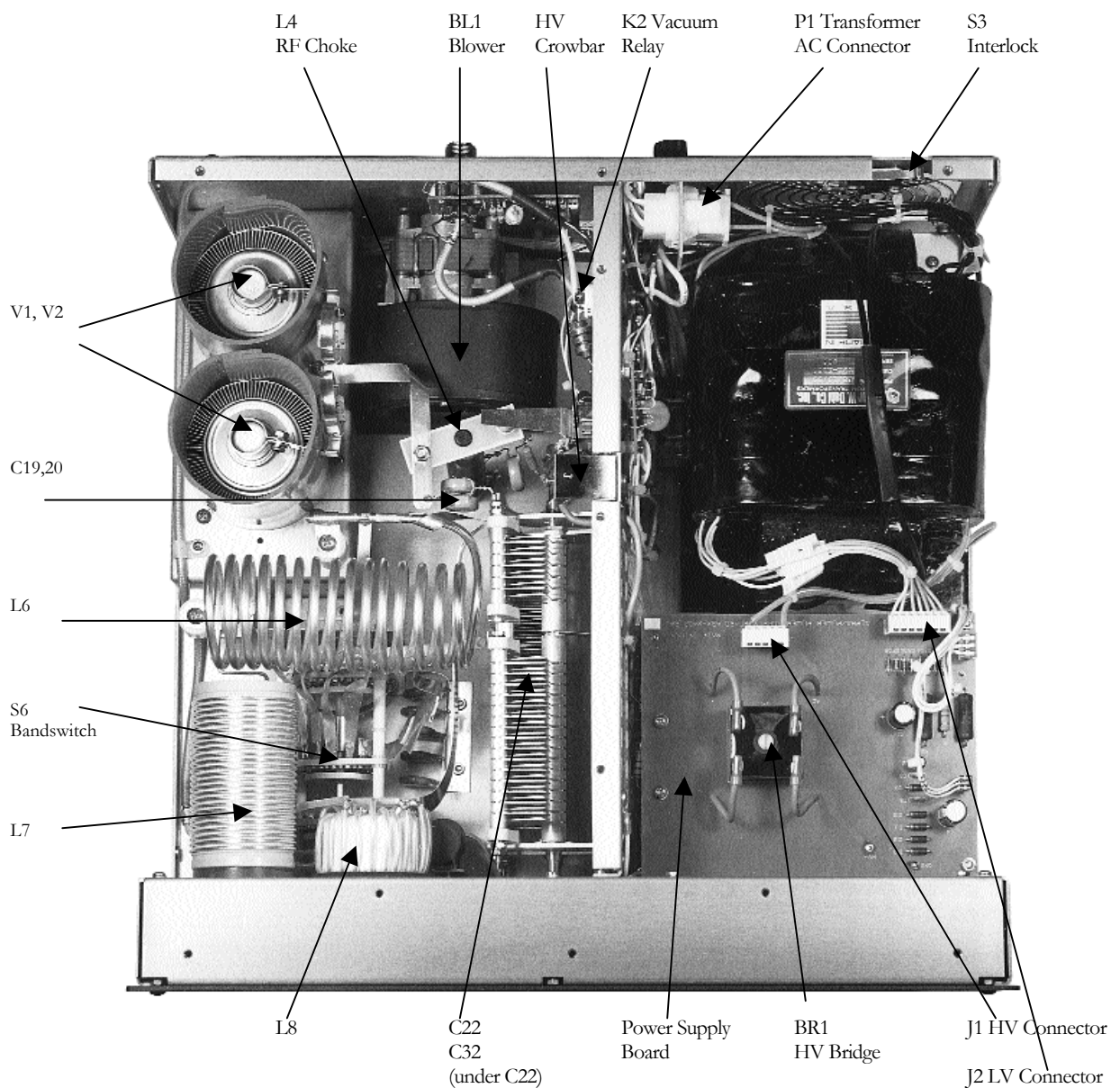

Overview of Amplifier Capabilities

It is extremely important to thoroughly review the Installation and Operation sections of this manual before attempting to use the ALPHA 99. Failure to do so could result in serious damage not covered under warranty.

- Continuous RF Output. The 99 is capable of 1.5kW continuous RF output on all commonly used modes and on any authorized amateur frequency from 1.8 to 29.7 MHz.
 - Compatibility with popular amateur transceiver and excitors. It requires approximately 50-55 watts peak RF drive for 1.5kW output.
 - Capable of full CW break-in, QSK and all digital modes when used with any appropriate transceiver.
 - Protective functions built in. The control system incorporates protective functions that minimize the probability of accidental damage to the amplifier or its power tubes. In most cases, when one of the protective functions is “tripped,” the amplifier will go to Standby.
 - Optional auxiliary cooling fan available. We recommend using the external auxiliary fan for extended RTTY or other “locked key” service. This is available separately from Radio Alpha Products. The cooling fan is required for operation with a 50Hz power source.
-

Unpack and Prepare for Operation

(Refer to Figures. 1-5, pages 13, 19, 21)

Carefully unpack amplifier and transformer.

Inspect both for physical damage. Save all packing material for future use.

AC Primary Connections & Amplifier Grounding.

Remove the amplifier top cover. Primary voltage taps are selected at the terminal strip numbered “1” to “7” and located on the mains board mounted on the chassis center divider, left of the transformer. Connect the two wires labeled “A” and “B” for the line voltage to be used, as shown in the following table. The two short jumper wires supplied are not used on 190-250V, but must be connected as shown for operation on 90-130V mains.

Install the transformer.

Only one possible transformer orientation allows mating all its connectors without straining leads.

Warning! The transformer is very heavy and must be moved with due caution using only the lifting handle.

Lift the transformer high enough to clear the right side chassis lip and move it sideways into the chassis. **USE CAUTION! PROCEED SLOWLY** to avoid damaging wires or components. From underneath, insert the supplied bolts with washers through the clearance holes in the chassis and into the nuts in the transformer base. **CAUTION!** Mate transformer connectors carefully and gently to insure that all connector pins engage correctly and fully.

While the top cover is removed, make sure each tube are firmly seated in its socket, rubber exhaust chimneys is fully and correctly installed, and anode connector is tightly clamped to each tube. The silicone rubber chimneys installed on the 4CX800 tubes are

an absolutely essential part of the cooling system. Make sure the chimneys are straight and fully installed so that the bottom of the chimney is firmly against the tube deck and completely covers the airflow openings in the deck. Tube cooling air must exit only through the tube anode fins; it must not be allowed to escape outside them. Failure to ensure proper cooling airflow may result in tube damage or destruction which is not covered under warranty.

AC Primary Connections & Amplifier Grounding

Primary voltage taps are selected at the terminal strip numbered “1” to “7” and located on the mains board mounted on the chassis center divider, left of the transformer. Connect the two wires labeled “A” and “B” for the line voltage to be used, as shown in the following table. The two short jumper wires supplied are not used on 190-250V, but must be connected as shown for operation on 90-130V mains.

PRIMARY	“A” Terminal	“B” Terminal	Blower*	Jumpers
230-250V	4 **	2**	4 & 2**	Not used for 190 - 250V operation
210-230V	4	3	4 & 3	Not used for 190 - 250V operation
190-210V	5	3	4 & 3	Not used for 190 - 250V operation
110-130V	4	6	4 & 7	1 - 2, 6 - 7
90-110V	5	6	4 & 7	1 - 3, 6 - 7

* The blower wires are the 2 black wires marked “4” and “X”, (4 to terminal 4, X to 2, 3, or 7 per table). Optional external muffin fan has 2 black wires, one is connected with blower wire 4 and the other to the same terminal as blower wire X (2, 3, or 7 per table)

** Factory settings.

NOTE: If you intend to operate the amplifier on any of the 90 - 130V settings, the two lower fuses on the rear panel (2 amp) will have to be changed to 5 amp to allow for the increased in-rush current.

NOTE: Do not operate amplifier without the cover in place and all cover screws installed. Do not operate amplifier without a good RF ground connection on the rear panel ground terminal.

Power Cord Connections

WARNING!

To avoid the hazard of a potentially fatal electric shock and/or severe damage to the ALPHA 99 and other equipment, always use an AC plug that is appropriate for the primary mains voltage, current rating and configuration. NEVER use 120V-type plugs and power receptacles for 190-250V circuits.

ALWAYS use grounding type AC connectors which conform to local codes and ensure that the green wire in the Alpha 99 power cable is wired only to the AC mains safety ground (or to neutral, as may be necessary with a 240V circuit configured 120V-N-120V without a separate ground, commonly found in the US).

The green conductor in the power cord is wired to the ALPHA 99 chassis. It MUST be connected only to the power source safety ground or neutral. The black and white power cord wires connect to the two “hot” wires of the AC source; either wire may be connected to either side of the line. For best results use a dedicated 200-240V branch circuit of #10 AWG copper wire or equivalent, rated at 20A, to feed the amplifier.

Important information concerning operation from 90-130V AC

Electrical power equipment will draw twice as much primary current from 120V mains as from 240V mains. Therefore, operating the ALPHA 99 on a typical 120V/20A household circuit without exceeding the 20A circuit rating will limit maximum peak power output to about 600-1000 watts. Maximum possible RF output power for any particular primary AC voltage and current capacity may be estimated as:

$$P_{o \max} = (V_{\text{LINE}} \times I_{\text{LINE}}) / 2.3.$$

For example, if the Alpha 99 operates from a circuit which is capable of delivering 115V AC at a maximum current of 20A, with no other loads connected to the circuit, maximum peak RF output possible without tripping the 20A breaker (or fuse) is approximately:

$$P_{o \max} = (115V \times 20A) / 2.3 = 2300/2.3 = 1000 \text{ watts.}$$

If the same circuit also supplies a transceiver drawing peak line current of 5A and a lamp drawing 1A, only 20-5-1 = 14A is available for the amplifier and maximum possible output is about:

$$P_o \text{ max} = (115V \times 14A) / 2.3 = 1610 / 2.3 = 700W.$$

RF Grounding

A ground stud with wing nut is provided on the rear of the chassis. Connection should be made from this stud to a good RF earth ground, such as a copper water pipe or driven rod, via heavy copper braid or strap. **CAUTION:** When using any high power amplifier, failure to connect ALL station equipment to a good common ground may allow RF feedback to leak into the transceiver and cause severe signal distortion.

Replacing the Amplifier Cover

Use only the 6-32 screws supplied with the amplifier and do not tighten any of the screws until all are started. Do not attempt to operate the amplifier with the cover removed. This **WILL** cause damage to the Alpha 99 and may also lead to injury or death to the operator.

Internal Blower/Auxiliary Fan

Remove the blower motor shipping hardware (two 10-32 bolts, fiberwashers, rubber shim) from rear chassis wall. Save this hardware! It must be reinstalled whenever the chassis is transported. For heavy-duty use or 50 Hz operation, the optional auxiliary fan is required.

Figures 2 - 4 - Transformer Installation

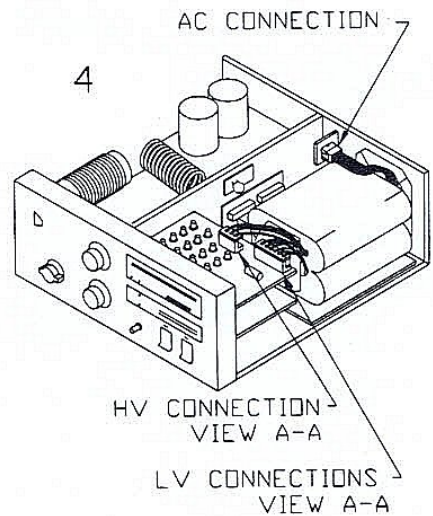
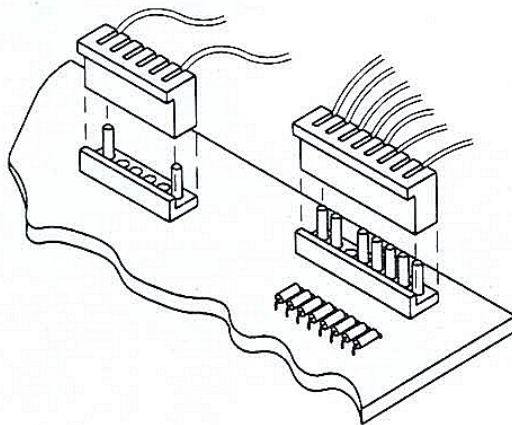
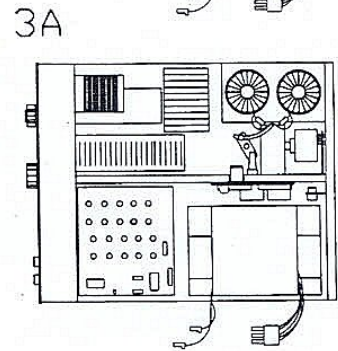
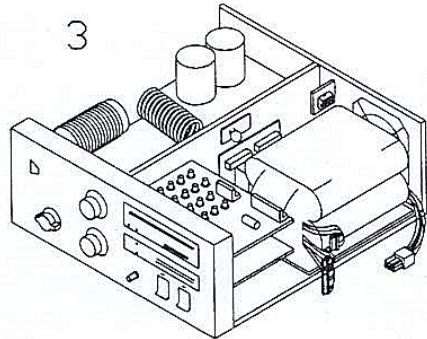
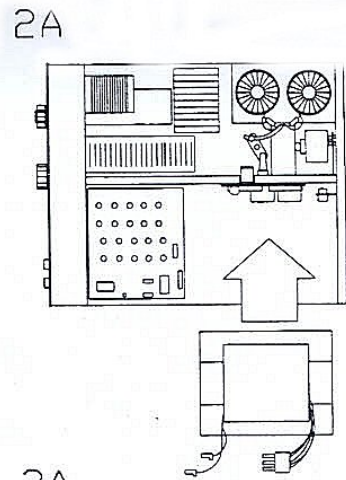
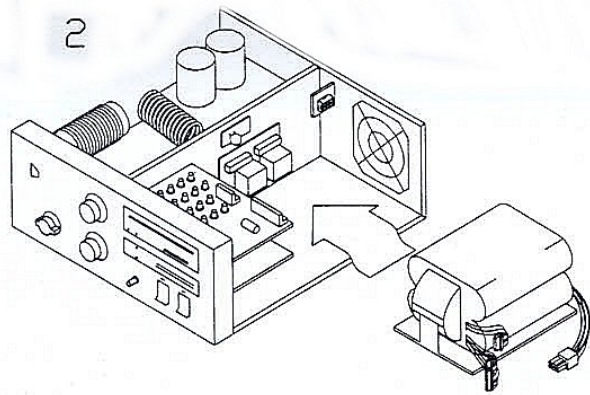

VIEW A-A
HIGH AND LOW VOLTAGE BOARD CONNECTIONS

**FIGURES 2-4
ALPHA 99
TRANSFORMER
INSTALLATION**

Amplifier/Station Interconnections

See figure 5

Coaxial Cable Types & Connectors

Connect the transceiver RF output to the ALPHA 99 RF INPUT with 50 ohm coaxial cable- RG-58C/U or equivalent. A 6 ft. cable is supplied for this purpose.

Coaxial cable from the 99 RF OUTPUT to antenna should be RG-8A/U, RG-213/U, or equivalent high quality type with a PL-259 UHF-type plug on the amplifier end. RG8X cable is not recommended.

T/R Control Cable

The Alpha 99 has a full break-in vacuum relay QSK system requiring only the normal interconnection when used with a modern QSK transceiver. The Alpha 99 requires a contact closure (short circuit) on transmit from its RELAY jack center pin to chassis. This function is supplied by the transceiver, usually from a dedicated relay that is normally open in receive and closed in transmit. Shielded wire should be used for the T/R control cable. The Alpha 99 end must be fitted with a common phono (RCA-type) plug and the other end with a connector suitable for the transceiver.

The T/R relay contact must close before application of RF drive. The Alpha 99 protection circuitry prevents “hot-switching” with RF drive applied. Modern transceivers have the proper time delay between keyup and the start of the transmitted signal to allow the Alpha 99 to follow the CW keying. If a T/R timing problem is suspected, connect the CW keyer to the RELAY jack on the Alpha 99, and connect a cable from KEY OUT on the amplifier to the keying input of the transmitter.

ALC

The use of ALC output on the rear of the 99 chassis is not normally needed or recommended when the ALPHA 99 is used with modern transceivers. However, the Alpha 99 does generate a negative ALC control voltage that can be fed back to most transceivers if required, to minimize the possibility of overdriving the amplifier. This external ALC voltage is available at the amplifier’s rear panel ALC jack via a common phono connector. Alpha 99 grid current exceeding about 3mA will initiate ALC and light the green GRID LED. About 5-10mA yields full ALC output-nominally -10 Vdc - and the red GRID LED lights. If the exciter requires a lower ALC voltage, the Alpha

99 ALC potentiometer may be set accordingly. While driving the amplifier, adjust the ALC pot to limit maximum transceiver output as desired. We recommend contacting Radio Alpha Products customer service before attempting to use external ALC with the Alpha 99.

Figure 5 - Alpha 99 Rear panel

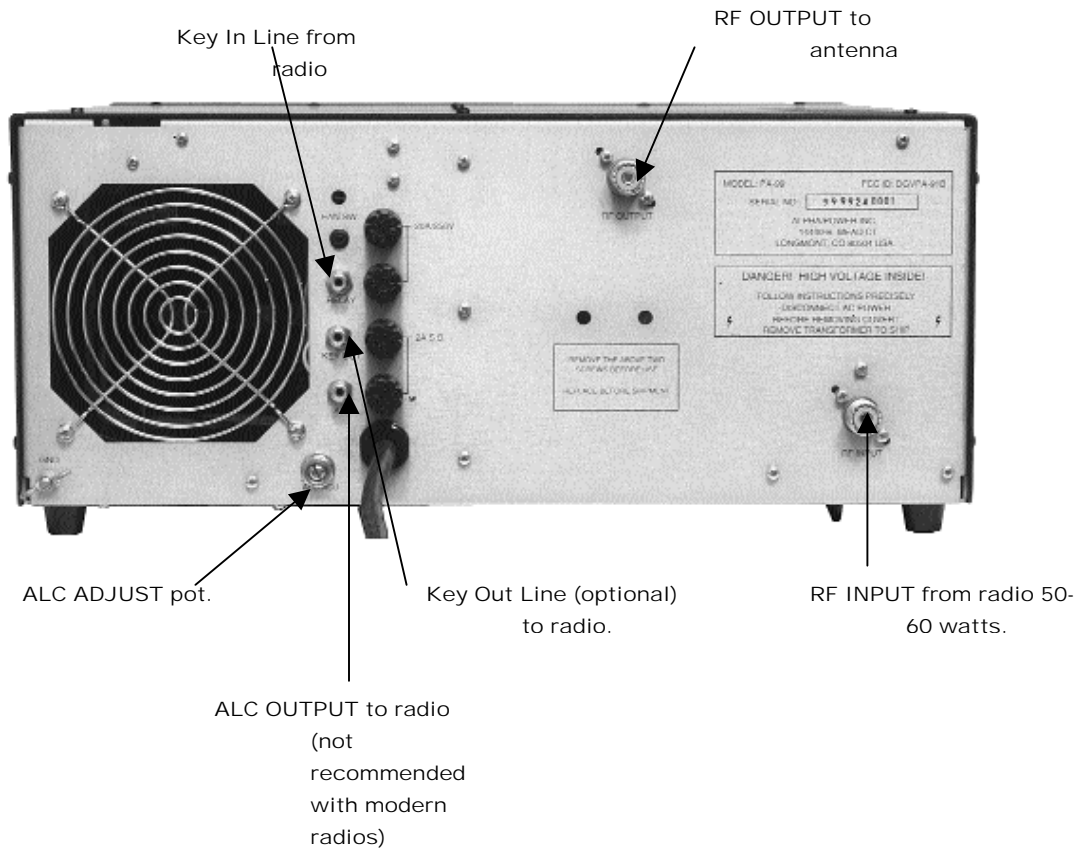

Initial Set-up and Tuning

Control Functions

(See front cover photo)

BAND	Use to select amateur band desired (in MHz).
TUNE	Sets output tank circuit to resonance. Higher frequencies tend to tune toward the “0” end of the dial scale, while lower frequencies tend to tune further toward the “100” end.
LOAD	Sets amplifier plate loading and determines the power level at which best efficiency and linearity are achieved. In general, loading is heavier at greater scale settings. Higher frequencies tend to load more toward the “100” end of the dial scale and lower frequencies toward the “0” end.□
POWER	Press ON to apply primary AC power to the amplifier or to reset power if the plate overcurrent relay has tripped. Press OFF to remove primary AC power.
OPR/STBY	Operate places the amplifier in-line. With the 99 off, in STandBY, or in warm-up with the WAIT LED lighted, the amplifier is bypassed and the exciter is connected directly to the antenna.□
Metering LEDs & Bargraphs	Separate bargraphs provide instantaneous full-time display of peak values.□
RF OUTPUT and REFLECTED	Red and green “GRID” LEDs indicate, respectively, that normal peak drive has been reached and the onset of

POWER:	overdrive and flattopping. A switch-selected bargraph monitors three additional functions:
TUNE:	Permits a simple and safe tune-up procedure to be performed at low output power. See section Tune-up below.
IP:	Plate current, 1.5 amperes full scale (approximately 75 mA per segment).
HV:	Plate voltage, 3000 VDC full scale (150 V per segment).

Tune-up

The objective of tune-up is to adjust the amplifier (and the drive applied to it) to obtain optimum efficiency and linearity at the desired output power. Any linear amplifier must be adjusted for optimum efficiency and linearity at each specific power level. If operation at higher power is then attempted without appropriate readjustment, the result will be flattopping, “splatter,” and (usually) excessive amplifier grid current. If operated at a much lower power level than it has been adjusted for, the amplifier’s efficiency decreases considerably.

Grid Current

The ALPHA 99 operates in Class AB2 when delivering maximum output power consistent with excellent linearity. A small amount of grid current flows and the green GRID MIN LED lights as drive approaches the optimum level. The green GRID LED will flicker on SSB voice peaks, and light under CW/SSTV/RTTY carrier conditions.

As overdrive approaches, grid current increases rapidly and the red GRID MAX LED lights. At maximum output and efficiency, the red LED lights dimly; full illumination of the red LED indicates overdrive and must be avoided. If the red LED lights before the desired value of plate current and/or power output is reached, readjust amplifier loading before continuing.

On SSB, optimum output consistent with good linearity occurs when the green GRID LED lights on most voice peaks and the red LED flickers dimly only on the highest peaks.

Excessive grid current results from overdrive and/or inadequate loading. The solution is to reduce drive, and/or increase amplifier loading. The 99’s 4CX800A/GU74b tubes are well protected and these adjustments tend to be less critical than in many

other amplifiers.

ALC

The 99 grid current limiting circuits provide substantial tube protection against possible damage. The ALC voltage generated by the 99 is for external feedback to transceivers. It cannot control the amplifier itself and is not applied internally. If ALC control is required, a connection must be made from the 99 to the transceiver ALC input.

Warm-up Procedure

NOTE: The forward and reflected power LED bargraphs and GRID LEDs are peak-responding.

BEFORE INITIAL TUNE-UP, MAKE SURE A SUITABLE ANTENNA OR 50 OHM DUMMY LOAD IS CONNECTED TO THE 99. Leave the amplifier off or in standby and apply exciter power to make a forward vs. reflected power check. If reflected power is less than ten percent of forward power, the VSWR is lower than 2:1 and it is safe to proceed with tuneup.

Turning on the amplifier:

1. Place the OPR-STBY switch in STBY (standby).
2. Rotate the multimeter selector switch to HV.
3. Depress POWER/ON. If any of the following does NOT occur, depress POWER/OFF switch immediately and investigate before proceeding:
 - a. The blower starts (note air exhausting above tubes).
 - b. The multimeter bargraph automatically displays HV; it should indicate approximately 2.8 to 3.0 KV.
 - c. The WAIT LED is lighted

IMPORTANT: EXHAUST AIR MUST BE DETECTABLE FROM THE TOP VENTS: If it is not, TURN OFF the amplifier immediately and verify that the exhaust chimneys are properly positioned over the tubes. When the warm up delay is complete (about 150 seconds), the WAIT LED will extinguish. The ALPHA 99 is now “ready”.

1. Tuning Up for Operation at 1,500 Watts RF Output

Presets BAND, TUNE, and LOAD controls to the nominal positions given in Table 1, below*:

Table 1 - Preliminary Tuneup Settings			
Band (MHz)	Frequency (MHz)	Tune	Load
1.8	1.8	60	14
1.8	2.0	20	65
3.5	3.5	67	40
3.5	3.75	58	60
3.5	4.0	50	75
7	7.15	45	35
10	10.13	15	26
14	14.2	70	40
18	18.1	50	55
21	21.2	40	65
24	24.9	65	60
28	28.0	32	72
28	28.6	24	74
28	29.7	18	76

*Each Alpha 99 shipped from our factory will include an individual table showing the tune and load settings we used to achieve full output power on that amplifier into a 50 ohm delivery load. These settings may vary slightly from those in the manual.

NOTE: Final TUNE and LOAD settings will vary with the operating frequency, antenna characteristics and power level.

2. Reduce transceiver carrier output control to ZERO.
3. Press OPR (operate) on OPR-STBY switch. OPR LED should light.
4. Select TUNE function of the multimeter bargraph.

IF AT ANY TIME IN THE FOLLOWING PROCEDURE THE AMPLIFIER FAILS TO RESPOND AS DESCRIBED, REMOVE DRIVE IMMEDIATELY!

5. Switch transceiver to CW and increase its carrier output to approximately 15 watts (99 output approx. 300-500 watts).
6. Adjust TUNE control to deflect the TUNE LED maximum leftward.

7. Adjust LOAD control to place the illuminated TUNE LED at the “V” mark on the TUNE scale.
8. Repeat steps 6 and 7 at least twice.
9. Increase excitation until 99 output is about 1500 watts.
10. Repeat steps 6 and 7 at least twice.
11. Touch up TUNE for maximum power output.

The ALPHA 99 is now correctly tuned to deliver 1500 watts RF output on SSB, CW, FSK, SSTV and FM. The TUNE LED normally fluctuates during modulation or keying. Illumination of the first red LED on the RF OUTPUT bargraph indicates output has exceeded 1500 watts.

To operate at reduced power in any mode, decrease drive (i.e. transceiver power output) and doublecheck all tune settings for efficient and RF-clean operation.

Use and Maintenance

Tubes

The 4CX800A/GU74b tubes used in the ALPHA 99 are very rugged and normally operate with a large margin of safety. They should provide outstanding service for many years if not damaged by abuse - especially overdrive or blockage of cooling airflow. Allow at least twelve inches (31 cm) unobstructed clearance around the air intake and exhaust areas. Stacking equipment is not recommended.

Never allow key-down plate current to exceed 1.5 amperes for more than one or two seconds. If you do and a plate current trip occurs, it will automatically reset in about 4 seconds if the amplifier is returned to receive (key-up).

Never allow the red GRID LED to stay brightly illuminated for more than a second.

Frequent on-off AC power cycling may shorten tube life. It's better to leave equipment in standby for several hours than to cycle power repeatedly on-off-on-off over the same period.

Interlocks

The ALPHA 99 is equipped with a cover interlock switch intended to remove primary power from the amplifier, and a crowbar to short-circuit the high voltage to chassis whenever the cover is lifted. These interlocks are designed to protect against dangerous electric shock resulting from accidental contact with the lethal voltages inside the amplifier.

WARNING!

ALWAYS DISCONNECT THE AC LINE CORD FROM THE POWER SOURCE BEFORE REMOVING THE TOP COVER FROM THE 99 FOR ANY REASON!

Cover interlocks are intended only as back-up protection against accidents. Never depend on them! Always disconnect the power cord from the AC mains before removing the cover! Interlock switches should never be disabled for any reason.

Fuses

Never replace any fuse with one of a different type or greater current rating. Blowing of one or both primary line fuses indicates that the maximum safe average power capability of the amplifier has been substantially exceeded or that an equipment failure has occurred. USE ONLY 20 AMP, 250 VOLT RATED FUSES for 190-220 VAC service.

Slow-blow fuses F3 and F4, located above the primary line fuses, may prevent damage to the step-start resistors and HV rectifiers in the event of abnormal turn-on conditions or HV faults. If the AC interlock is defeated and primary power is applied while the HV crowbar is closed, the step-start fuses normally will blow.

DAMAGE RESULTING FROM USE OF A FUSE OF INCORRECT SIZE OR TYPE WILL NOT BE COVERED UNDER WARRANTY AND MAY VOID THE WARRANTY.

Plate Overcurrent Relay

This relay will quickly turn off the amplifier in the event of grossly excessive plate current or fault in the high voltage circuitry. The relay will not prevent tube or other damage due to either short or long term overdrive or improper tuning. It is the operator's responsibility to ensure safe tuning, drive, and general operating conditions. Should the overcurrent relay trip, remove AC power from the amplifier, then determine and correct the cause of the trip before turning the 99 on again.

Idling Plate Current And Electronic Bias Control (Ebs)

Idling plate current of the ALPHA 99 is approximately 350 to 400 mA during fullpower transmission. A detector senses RF drive, and reduces plate current to 30-50 mA during pauses in speech and key-up intervals, thus substantially reducing average power supply loading, heat generation, and wasted energy.

RF & Mistuning Protection

ALPHA/POWER's exclusive circuit senses the beginning of any RF arc in, for example, a TUNE or LOAD variable capacitor and automatically switches the 99 to standby within a few milliseconds. This system has virtually eliminated RF arc damage in current ALPHA amplifiers. The system similarly detects severe mis-tuning of the 99, and if drive exceeds about 25 watts switches the amplifier to standby. The 25 watt input trip threshold permits safe tuneup at low power levels using the TUNE indicator, without aggravating and unnecessary trip-outs.

Preventive Maintenance

The amplifier interior, particularly high voltage areas, should be cleaned with a vacuum cleaner and a soft bristle brush frequently enough to prevent visible accumulation of dust. In extremely dusty conditions it may be advisable to secure a thin air filter of the type used for window air conditioners across the air intake on the rear panel. The ALPHA accessory cooling fan also should be installed to insure adequate cooling airflow.

There are no user-accessible lubrication points in the amplifier. Do not apply oil or grease to any of the components. The exterior of the ALPHA 99 may be cleaned with a mild household liquid detergent such as Formula 409 or Fantastik. Do not use chemical solvents, as these may severely damage the front panel or cabinet finish. Never use an abrasive cleaner.

Troubleshooting Hints

*NOTE: FCC rules do not permit new amateur amplifiers to be operable on 24-30 MHz as delivered within the US and possessions. As shipped to a US address, the amplifier is not operable on 21 MHz and above. Owners who send Alpha Power Customer Support a photocopy of their authorizing amateur license will promptly be provided information on “unlocking” 12 and 10 meter coverage.

99 will not turn on; nothing happens when ON switch is pushed.

- 1) External AC wiring, fuse or circuit breaker may be open.
- 2) Amplifier cover not in place; cover safety interlock open.
- 3) Fuse F1-F4 open or missing; check fuses with an ohmmeter.
- 4) Step-start resistor R4 or R5 open.

Amplifier turns on but no HV is indicated by the multimeter LED bargraph.

- 1) Multimeter selector switch in wrong position, e.g., Ip.
- 2) Possible HV circuit fault.
- 3) HV sampling resistor in power supply damaged.
- 4) Transformer plugged into power supply incorrectly.

Amplifier turns on but no multimeter indications; other LED bargraphs are operative.

- 1) Low voltage power supply problem.
- 2) Defect or damage on control board.

Amplifier turns on but time delay will not complete; WAIT LED does not turn off.

- 1) Defect or damage in timing circuitry on control board.

Amplifier turns on, time delay completes but amplifier will not transmit.

- 1) Open T/R control line from transceiver to RELAY jack.

Amplifier transmits but red GRID LED often lights.

- 1) Amplifier overdriven or underloaded; reduce transceiver output and /or increase amplifier loading.
- 2) Load VSWR (reflected power) exceeds 200W.
- 3) Exciter output poorly controlled. External ALC may help.

Amplifier operates but green GRID LED will not light and plate current is low; transceiver does not seem to be able to drive amplifier to its rated RF output power level.

- 1) External ALC control voltage to transceiver excessive (see Section 5, Automatic Level Control).
- 2) Input rf load resistor or bias circuitry damaged.
- 3) Possible damaged or defective tube(s).

Receive signals disappear or are severely attenuated when switching from STBY to OPR.

- 1) RELAY (T/R) control cable from transceiver is shorted.
- 2) Transceiver locked in transmit

Plate current indicated when amplifier is in STBY or receive.

- 1) 4CX800A/GU74b tube heater-to-cathode leakage or short.
- 2) Tube bias supply or T/R bias switch faulty.

Distorted SSB signal; possible severe television interference.

- 1) Excessive RF drive from transceiver and/or insufficient amplifier loading.
- 2) Coaxial connector, coax feedline, antenna feedpoint balun, tuner, or antenna trap arcing on voice peaks.
- 3) RF feedback from antenna into transceiver via the transceiver power cord,

microphone or key cable, or other unshielded station patch cables.

- 4) Poor station RF ground.

Low frequency audio hum on transmitted signal.

- 1) Defective microphone cord (especially, broken ground lead).
- 2) Dynamic (magnetic) microphone located within about two feet of 99 power transformer. All dynamic microphones pick up some magnetically-coupled hum from the external field of nearby power transformers. In cases where objectionable hum is experienced while using the 99 and popular microphones such as the Heil series, the problem usually can be resolved by keeping the microphone at least 18 to 24 inches from the front of the amplifier and ensuring that transceiver mike gain, speech processing, and internal drive (ALC) levels are not adjusted to exceed 10 dB. In rare cases it may be necessary to use a ceramic or condenser type microphone.

Figure 6 – Simplified Chassis Schematic

Figure 7- Display Board ABX-X400

Figure 8 – Control Board ABX-X401

Figure 9 – Control Board ABX-X401
Page 2 of 2

Figure 10 – T/R Status Board, Multimeter Switch and Switch Matrix Board

Figure 11 – Power Supply Board

Figure 12 – HV Filter and Screen Supply Board

Figure 13 – T/R Status Board and Multimeter Switch

Figure 14 – Output Wattmeter Board

Figure 15 – Center Partition Board

Figure 16 – Tube Deck BCX-X413

Figure 17 – Wiring Harness

ALPHA PRODUCTS WARRANTY

RADIO ALPHA PRODUCTS, INC WARRANTS AS FOLLOWS EACH NEW ALPHA/POWER AMATEUR RADIO PRODUCT OF ITS MANUFACTURE, SOLD AND USED IN THE UNITED STATES, ITS POSSESSIONS, AND CANADA:

Workmanship and all components **except if power tubes** are warranted for FOUR YEARS from date of original purchase if used exclusively in licensed amateur radio service. WARRANTY IS VOIDED BY ILLEGAL SALE OR USE OF EQUIPMENT (e.g. U.S. sale of export models).

Eimac power tubes are warranted by their manufacturer; Radio Alpha Products will assist owners in securing warranty service if requested. Determination by Eimac as to warranty coverage is binding on customer.

Svetlana power tubes are warranted by Radio Alpha Products for one year from date of original purchase.

Warranty does not apply to repair of damage or failure resulting from improper maintenance or repair, misuse, neglect, abuse, or improper installation, nor to units not operated in accordance with specifications and instructions furnished by Radio Alpha Products, nor to units repaired or altered by persons not authorized by Radio Alpha Products, nor in cases where the serial number has been removed, altered, or defaced.

If a malfunction is suspected, before attempting repairs or returning equipment to Radio Alpha Products or the selling dealer for service, the owner shall contact Radio Alpha Products or the selling dealer factory service department, providing model and serial number plus details of equipment hookup, accessory equipment used, operating conditions, and abnormalities observed. Radio Alpha Products will furnish a new part in exchange for any covered defective part or, if it is determined that factory service is required, will authorize return to factory. Equipment authorized for return shall be shipped to Radio Alpha Products fully prepaid and insured via United Parcel Service or air express, **USING ONLY FACTORY APPROVED PACKING. REMOVE POWER TRANSFORMER BEFORE SHIPPING, also remove your power plug before shipping.** All shipping and insurance charges are the responsibility of the owner.

In order to receive service under this warranty, the owner must either (a) have returned a completed warranty registration form to Radio Alpha Products within 30 days of original purchase OR (b) provide proof of ownership as well as proof of the original date of sale by Radio Alpha Products or by an authorized ALPHA/POWER dealer.

No person is authorized to assume for ALPHA/POWER any liability in connection with our products, other than as set forth in this warranty. ALPHA/POWER reserves the right to change its products as it deems desirable, without obligating itself to make such changes available for previously manufactured products.

UNDER PROVISIONS OF THE FEDERAL MAGNUSON-MOSS WARRANTY ACT, THIS WARRANTY
POLICY IS CLASSIFIED AS A LIMITED WARRANTY.

