

ALPHA 99

HF LINEAR AMPLIFIER

OPERATING MANUAL

© 2006 Alpha Radio Products, Inc
All rights reserved
Specifications subject to change without notice

ALPHA 99 OPERATING MANUAL

www.alpharadioproducts.com

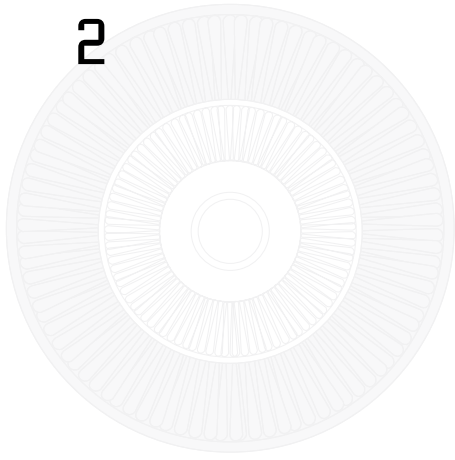

ALPHA 99 OPERATING MANUAL

www.alpharadioproducts.com

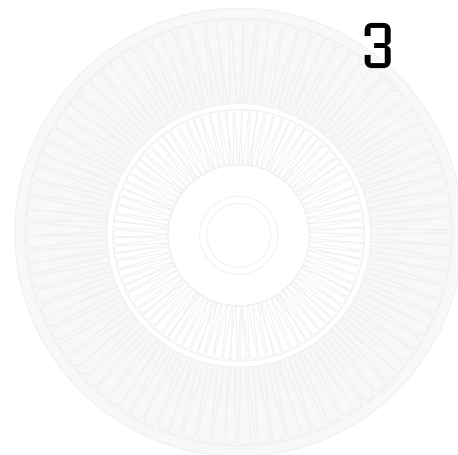

Table of Contents

1 Introduction 7

- 1.1 General Description 7
- 1.2 Amplifier Capabilities 8
- 1.3 Shipping Information 8
- 1.4 Safety Information – Installation and Operation 8
- 1.5 Owner Assistance 9

2 Quick Start Information 11

- 2.1 Overview 11
- 2.2 Station Engineering Considerations - Checklist 11
- 2.3 Preparation 11
- 2.4 Unpacking 12
- 2.5 Operation 12

3 Station Engineering Considerations 13

- 3.1 Overview 13
- 3.2 AC Power Source 13
- 3.3 Air Flow 13
- 3.4 Antennas 14
- 3.5 Coax and Connectors 15
- 3.6 RF Safety 15

4 Unpacking & Preparation 17

- 4.1 Unpacking 17
- 4.2 Installing the Power Transformer 17
 - 4.2.1 Install the Power Transformer 18
 - 4.2.2 Connecting the Transformer Power Plugs 20
 - 4.2.3 Power Cord Connections 21
 - 4.2.4 Important Information About Operation from 90-130V AC 21
- 4.3 AC Primary Connections 22

4.4 Complete the Transformer Installation	25
4.4.1 RF Grounding	25
4.4.2 Replacing the Amplifier Cover	25
4.4.3 Blower Preparation	25
4.5 Amplifier/Station Interconnections	25
4.5.1 Coaxial Cable Types & Connectors	25
4.5.2 T/R Control Cable	26
4.5.3 ALC	26

5 Theory of Operation **29**

5.1 Theory of Operation - Overview	29
5.2 Tubes	29
5.3 Output Tank Circuit	29
5.4 Tube Deck	30
5.5 Mains Board	30
5.6 High Voltage Board	30
5.7 Control Board	31
5.9 Output Wattmeter Board	31
5.10 Center Partition Board	32

6 Operation & Maintenance **33**

6.1 Before Operating Your Alpha 99	33
6.1.1 Setting Input Drive	33
6.1.2 Dealing with faults	33
6.1.3 High SWR Considerations	34
6.1.4 Operating at Less Than 1.5 kW Requires Retuning	34
6.1.5 Lightning Protection	35
6.1.6 Operating in Bypass Mode	35
6.1.7 Never Use Transceiver Automatic Antenna Tuner	35
6.2 Transceiver Connections	35
6.3 Initial Setup & Tuning	36
6.3.1 Control Functions	36
6.3.2 Tune-Up	37
6.3.3 Grid Current Information	37

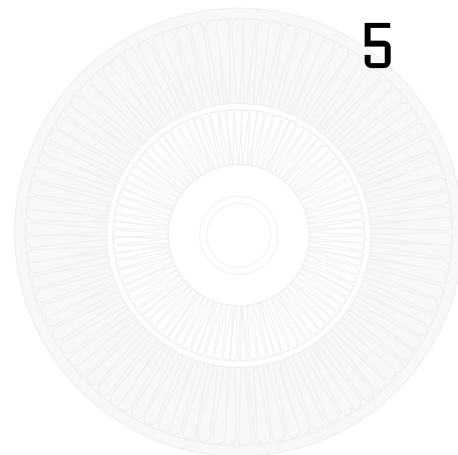

6.3.4 ALC	38	
6.3.5 Turning On The Amplifier		38
6.3.6 Tuning the Amplifier	39	
6.4 Normal Use	41	
6.4.1 Tubes	41	
6.4.2 Interlocks	42	
6.4.3 Fuses	42	
6.4.4 Plate Overcurrent Relay		43
6.4.5 Idling Plate Current and Electronic Bias Control (Ebs)		43
6.4.6 RF and Mistuning Protection	43	
6.5 Standard Maintenance Tasks	43	
7 Troubleshooting Hints		45
7.1 Normal Troubleshooting	45	
8 Glossary	49	

6

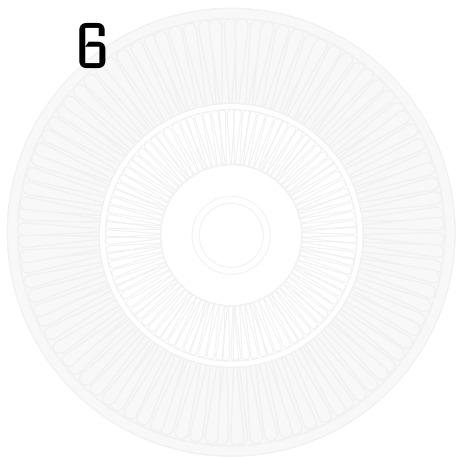

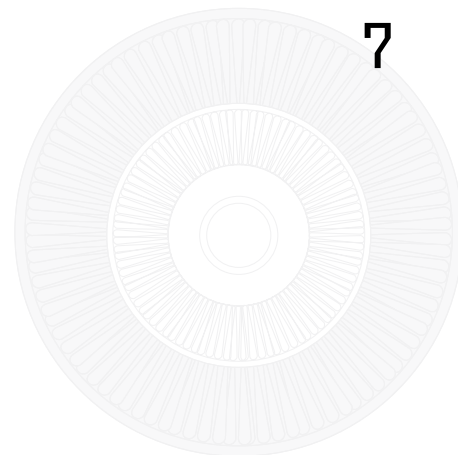

1 Introduction

1.1 General Description

Congratulations on your purchase of a professional quality Alpha 99 amplifier! With proper installation and care, you can expect to enjoy your Amateur Radio hobby with this amplifier improving your signal for many years to come. Please study this manual carefully before operating your amplifier for the first time.

The Alpha 99 is a self-contained manual tune HF linear power amplifier capable of continuous operation at 1500 W peak power output on SSB, keyed CW, SSTV, RTTY, digital modes or FM, with no time limit.

Other Alpha products available to enhance your use and enjoyment of the 99 amplifier include:

- Alpha 2100 full 1500-watt rated 50-ohm dummy loads and
- Alpha 4500 series SWR meters / Wattmeter

See our web site at www.alpharadioproducts.com or call 303-473-9232 for further information.



ALPHA 99 OPERATING MANUAL

www.alpharadioproducts.com

1.2 Amplifier Capabilities

CAUTION:

It is extremely important to thoroughly review the Installation and Operation sections of this manual before attempting to use the Alpha 99. Failure to do so could result in serious damage not covered under warranty.

- Continuous RF Output. The 99 is capable of 1.5 kW continuous RF output on all commonly used modes and on any authorized amateur frequency from 1.8 to 29.7 MHz.
- Compatibility with popular amateur transceivers and excitors. The 99 requires approximately 50-65 W peak RF drive for 1.5 kW output.
- Capable of full CW break-in, QSK and all digital modes when used with any appropriate transceiver.
- Protective functions are built in. The control system incorporates protective functions that minimize the probability of accidental damage to the amplifier or its power tubes. In most cases, when one of the protective functions is "tripped," the amplifier will go to Standby.

1.3 Shipping Information

The Alpha 99 amplifier ships in two heavy-duty cardboard cartons. One carton holds the power transformer and weighs 43 lb (20 kg) and the second carton contains the amplifier and weighs 38 lb. (17 kg).

Alpha recommends that you retain the pallet and the cartons after installation in the unlikely situation that you need to ship the unit later. Contact Alpha at 303.473.9232 for shipping advice and assistance.

1.4 Safety Information – Installation and Operation

- Make sure the Alpha 99 is located where there is good air circulation all around and on top of the cabinet. The unit may become hot during operation.
- The Alpha 99 weighs approximately 68 pounds when the transformer is installed. Use proper lifting techniques and two people when moving the amplifier.
- The Alpha 99 is designed to meet international safety standards and FCC regulations.

However, one should always remember that the equipment works with high voltages that can be LETHAL!

This operating manual holds information, cautions and warnings that must be followed to ensure safe installation and operation. Read Chapter 1 before attempting to unpack or operate the Alpha 99 amplifier.

Warnings: What Not to Do

- **Never open the amplifier case without unplugging the unit from the wall outlet.**
- **Never stick objects into holes in the case.**
- **Never touch an antenna during transmission.**
- **Never attempt to turn on the amplifier without the cover securely in place (all attachment screws reinserted).**
- **Never turn the amplifier back on after a hard fault without waiting at least 20 seconds.**
- **Always resist the temptation to immediately hit the ON button after the amplifier faults to power off.**
- **Never allow liquids to enter the amplifier through the cover holes.**

Warnings posted in this manual should be read and thoroughly understood by users. Failure to perform procedures properly may result in amplifier damage, fire hazard, or electric shock.

1.5 Owner Assistance

Technical Assistance from Alpha Radio Products is available from several sources.

- The Alpha Radio Products web site is www.alpharadioproducts.com. Click on Support and follow the instructions. Many typical problems and their solutions are listed on this site. On this site you can get the following assistance:
 - Technical Support
 - Repair Information
 - Software Downloads
 - Manuals
 - Tech Tips
 - Legacy Equipment Information
 - FAQs

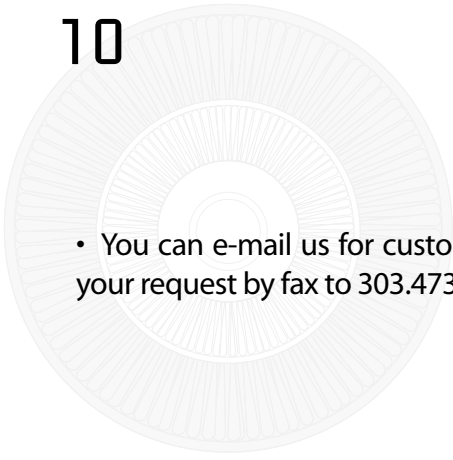

- You can e-mail us for customer support at service@alpharadioproducts.com or you can send your request by fax to 303.473.9660.

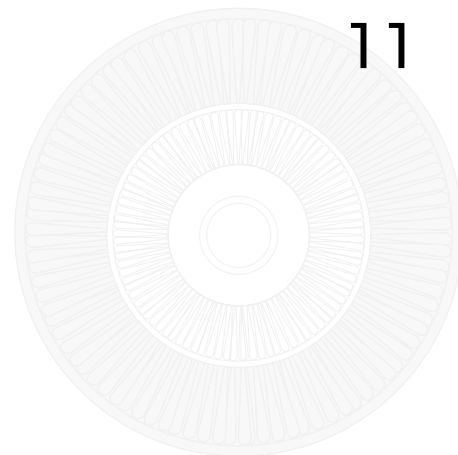

2 Quick Start Information

2.1 Overview

This section explains in brief the items you need to consider when setting up your Alpha 99 amplifier.

If you already have a well-designed shack and have used an amplifier before, please review the items below to make sure you have considered all the critical items for proper installation and operation.

If you are using an amplifier for the first time, please skip this section and go to sections 3, 4, and 5 for a more detailed explanation of how to set up your shack for maximum safety and operating enjoyment.

If you have installation questions, do not hesitate to contact Customer Support. We much prefer to address questions prior to power up.

2.2 Station Engineering Considerations - Checklist

Make sure you have properly addressed the following concerns (Section 2.3 below) before installation of your Alpha 99 amplifier. If you are unsure of any of these items, please read the noted sections carefully.

2.3 Preparation

- 220V AC Power in shack? (Section 3.2)
- Amplifier placed with proper airflow? (Section 3.3)
- Antenna ready for 1,500W? (Section 3.4)
- Adequate RF cabling? (Section 3.5)

2.4 Unpacking

- Unit Checked for Damage?
- Transformer Installed? (Section 4.2.1, 4.2.2)
- Power Cord Connector Attached? (Section 4.2.3)
- AC Primary Voltage Set? (Section 4.3)
- Amplifier Grounded Properly? (Section 4.4.1)
- Amplifier Cover Replaced and Secured? (Section 4.4.2)

2.5 Operation

- All Exciter Interconnections Set? (Section 6.2)
- Exciter Drive Correctly Set? (Section 6.1.1)
- Amplifier Tuned to Antenna System? (Section 6.3.6)

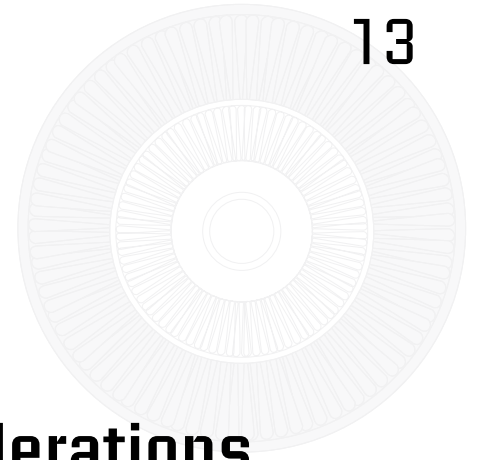

3 Station Engineering Considerations

3.1 Overview

The Alpha 99 is capable of dramatically improving the performance of your amateur station. It is important that you observe good engineering practices to achieve all the benefits of such a station in a safe and reliable manner. This section provides a few hints for important operational considerations, but it is recommended that the user also consult a good source of general information such as "The Radio Amateur's Handbook" by the ARRL, especially if this is the first high-power amplifier you have used.

3.2 AC Power Source

This amplifier runs best when powered by a 200V - 240V AC circuit. If you do not have a 220V AC outlet in your shack, you will need to get a licensed electrical contractor to install one. A minimum of a 20 amp capacity is required. A 20 amp breaker on your 220V circuit is sufficient. There are many styles of plugs, some of which are country-specific. For this reason, the amplifier is not shipped with a power plug. Select a location for the outlet as close as possible to where you expect to operate the 99. If you are not sure, or contemplate moving the amplifier, you may choose to get a second outlet installed at the same time. Ask your contractor for two or three matching plugs during installation as there are several styles of connector available. Ask the contractor to measure the voltage and record it, so you can set the line voltage tap on the 99 appropriately. If possible, have the contractor measure the line voltage with a 10 amp current draw, and use this value for setting the transformer tap. The Alpha 99 can run when connected to a 110V AC outlet. However, you WILL NOT achieve full legal limit output in this case. If the amplifier is connected to a 110V AC outlet, you should not expect more than 1000 W output.

3.3 Air Flow

It is critical that airflow around the Alpha 99 remain unimpeded at all times. Keep the top of the amplifier clear of any restrictions. If you are mounting the amplifier in a console, make sure that the exhaust air is properly and fully removed from the console. Poorly designed consoles can result in outlet air being drawn back into the amplifier air intake and recirculated, thus getting

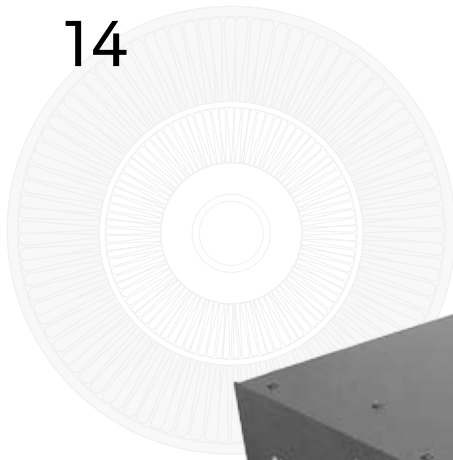

Figure 3.3 - Minimum clearance for proper airflow



To ensure adequate cooling make sure the top and rear of your amplifier have at least 3" of clearance to allow unobstructed airflow.

hotter and hotter and resulting in degraded amplifier performance or even failure. If you are designing your own console, consider putting in additional fans and/or ducting to deal with waste heat. Try to minimize the possibility of dust or other contamination getting drawn into or falling on the amplifier. It is also advisable to periodically (at least annually) clean the dust out of your amplifier for continued flawless operation. Alpha Radio Products recommends the use of compressed air for dust removal.

3.4 Antennas

Many antennas that are suitable for general use are unsuited for operation with a full 1500 W of power. At this power level in a 50-ohm circuit, the RMS current is 5.5 amps and the peak RF voltage is 387 volts. With a 2:1 SWR, these values double to 11 amps and 775 volts. The actual voltage and current at various points in or on your antenna may actually be many times these values. On a simple dipole with sharp wire ends, corona (localized ionization) can easily occur. Corona can (and has!) led to fire in nearby objects. Traps in beams and verticals can heat up significantly during high power operation. Instances of melting or flashover of traps have occurred in many installations where insufficient thought has been given to their ratings. If an antenna has been deployed for a long period of time, it may be worth taking it down for inspection prior to full power operation. If any insulators are cracked or show signs of "tracking", replace them. Doubling-up on insulators is also easy to do, and may prevent problems. If there

is any chance of people, animals or objects coming close to the antenna, take steps to move it higher, or place barriers so that this cannot happen. Check the SWR of your antenna; if you have a favorite part of any band you use most often, consider adjusting the antenna for minimum SWR in this part of the band.

3.5 Coax and Connectors

The importance of a well-constructed feed-line system cannot be overstated. After all, the purpose of the amplifier is to provide approximately 2 S units (12+ dB) of improvement in your radiated signal. All too often, installation problems are encountered where cheap, poor or under-rated coax and connectors are used. These often are responsible for at least one S unit of degradation. (This means you could have bought a 375 W amplifier and achieved the same radiated signal by buying good quality feed-line components!) Use the lowest loss 50-ohm coaxial cable you can obtain. Use new, clean connectors installed according to the manufacturer's recommendation. Clean the connectors after soldering them, and before mating them with the amplifier. Make sure any excess solder is removed from the connector; likewise remove any fragments of braid etc. Never use old coax, which may have had moisture penetrate under the jacket. Run the coax in straight lines as much as possible. Support it frequently using non-compressive clips so that it does not hang or stretch under its own weight. Avoid sharp bends (most manufacturers will specify a minimum bend radius for their product). Make sure the connection from feed-line to antenna is waterproof. Provide for disconnection of the feed-line when it is not in use; this protects against damage caused by power surges and lightning strikes, which are not covered under the amplifier warranty.

3.6 RF Safety

The FCC requires users to check their installations for compliance with published values for allowable exposure to RF fields. This information is available in ARRL publications, FCC printed rules, and on the web. Alpha Radio Products strongly recommends that this be done for any installation, both fixed and at an expedition or contest site.

If you have any questions regarding engineering your 99 into your amateur radio station, please visit our online technical support website at: www.alpharadioproducts.com

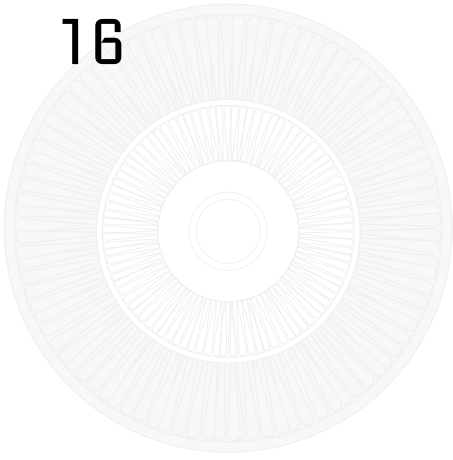

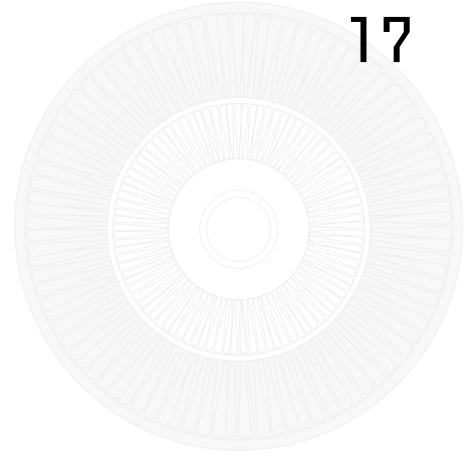

4 Unpacking & Preparation

4.1 Unpacking

Inspect both boxes for physical damage. Save all packing material (boxes and inserts) for possible future use. Contact 303-473-9232 if shipping damage is found. Carefully unpack the amplifier and transformer.

Carefully remove the amplifier and place it on a workbench or table where you can install the power transformer. This is a good time to remove the screws on the back panel which lock down the blower motor for transportation. Retain these screws, as they should be re-installed if the amplifier is shipped again.

4.2 Installing the Power Transformer

It is recommended that the power transformer be installed when the amp is at or near the place it is to be used. The chassis of the 99 is designed for the mechanical loads it experiences when the amplifier is on a flat surface with the tilt-bail up or down. If the amplifier is tilted too far, such that the transformer is cantilevered or "hanging out" to any degree, the chassis of the amplifier can distort. This may affect a number of things, from the alignment of screw holes on the top cover to the band-switch alignment and tension. If the amplifier is moved, even if only from one site to another locally, remove the transformer to avoid the possibility of damage.

CAUTION:

Do not operate amplifier without the cover in place and all cover screws installed. Do not operate the amplifier without a good RF ground connection on the rear panel ground terminal.

4.2.1 Install the Power Transformer

Place the amplifier on the bench or desk where it is to be used and remove the cover screws and the cover. Carefully lift the transformer by the handle and move it into place at the rear of the amplifier, taking care not to bump any of the boards and connectors on the power supply stack. Locate the set of 4 screws and washers that are supplied with your amp and used to secure the transformer to the chassis. Next, slide and rotate the amplifier so that the right back corner hangs over the edge of the bench and insert the screw from the bottom of the amplifier and turn it into the nut on the transformer plate. Continue this way, rotating the amplifier on the bench until all of the screws have been inserted and turned. Do not over tighten these screws as doing so may cause excessive vibrations or noise from the transformer. Figure 4.1 shows an alternate method of transformer installation.

Once the transformer has been installed and all of the screws are in place holding it to the chassis, you may proceed to attach the connectors as described in section 4.2.2.

WARNING!

The transformer is very heavy and must be moved with due caution using only the lifting handle.

CAUTION:

PROCEED SLOWLY to avoid bumping and damaging adjacent wires, connectors or components.

While the top cover is removed, make sure each tube is firmly seated in its socket, rubber exhaust chimneys are fully and correctly installed, and anode connectors are tightly clamped to each tube. The silicone rubber chimneys installed on the 4CX800 tubes are a critical part of the cooling system. Make sure the chimneys are straight and fully installed so the bottom of the chimney is firmly against the tube deck and completely covers the airflow openings in the deck. Tube cooling exhaust must exit only through the tube anode fins; it must not be allowed to escape outside them. Failure to ensure proper cooling airflow may result in tube damage or destruction, which is not covered under warranty.

**Figure 4.1
Transformer Installation**

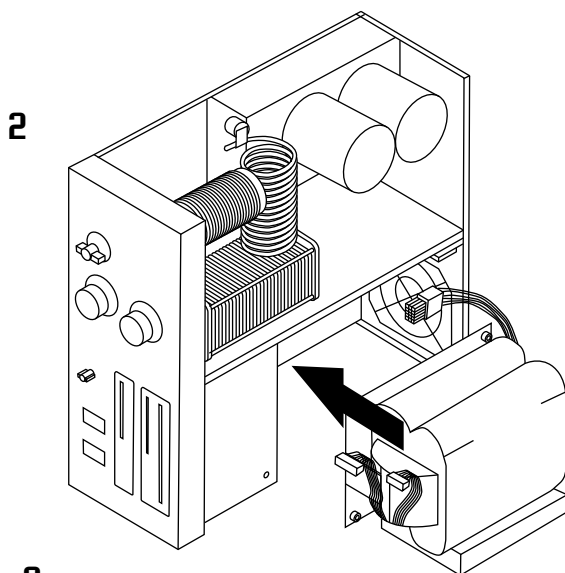
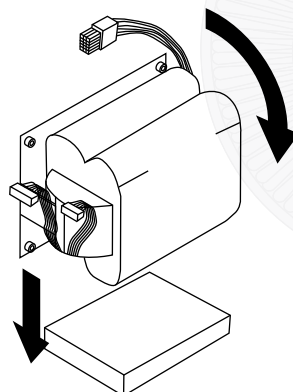
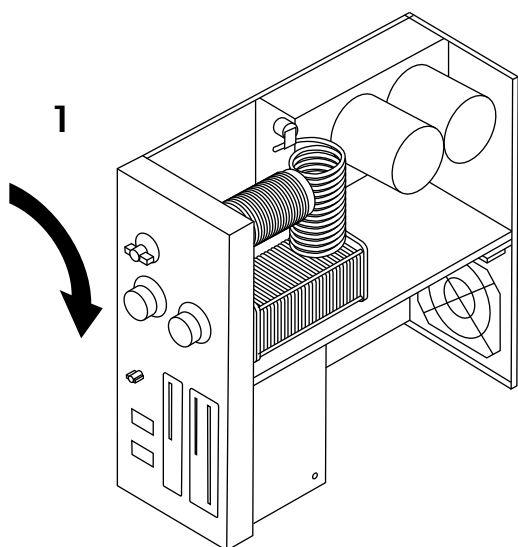

1. On a flat surface, with plenty of room, carefully rotate the amplifier on to its right side (power supply/transformer side). Rotate the transformer onto its right side, placing the transformer squarely on the transformer shim (the transformer should overhang the shim on all sides).

2. Slowly move the amplifier and transformer together making sure to align the nuts on the transformer with screw holes in the bottom of the amplifier.

3. Once the transformer is settled into position and the screw holes are aligned, secure the transformer into place from the bottom of the amplifier. Insert the supplied bolts (1/4 / 20, 1/2" hex bolts) with 1/4" washers through the four clearance holes in the chassis and into the nuts in the transformer base. Once the transformer is secure you may carefully rotate the amplifier back to its standard orientation.

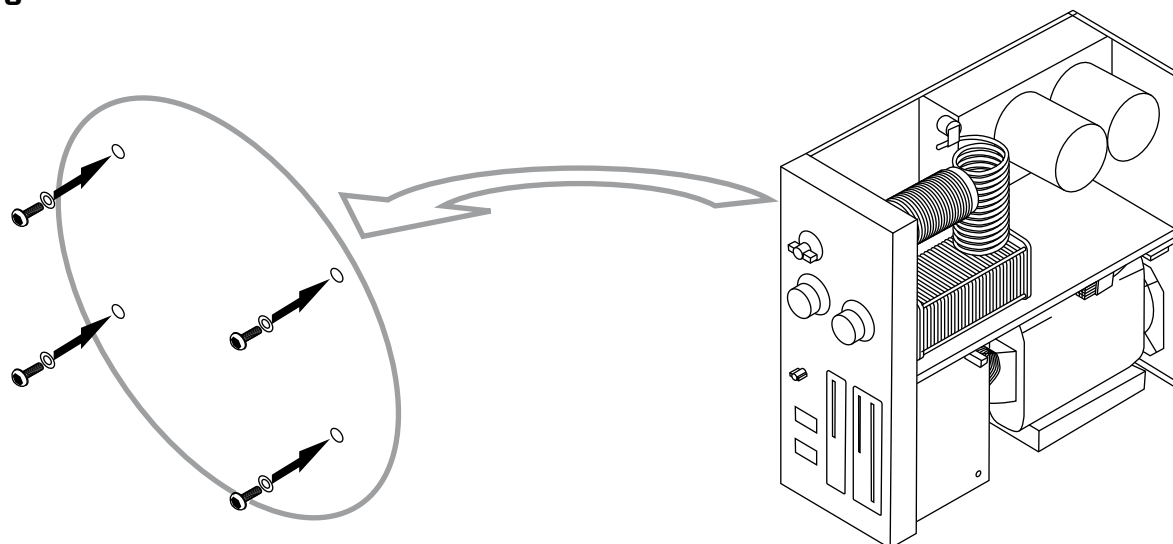

4.2.2 Connecting the Transformer Power Plugs

1. Connect the 9-pin white Molex connector to the matching plug mounted on the back wall of the amplifier.
2. Connect the 8-pin orange connector to the matching pins on the upper (Mains) PCB.
3. Connect the 6-pin yellow connector to the matching pins on the lower (HV) PCB.
4. Check to be sure that all connector pins on these three connectors engage fully and correctly.

AC to Transformer Connector (Molex)



Found towards the back of the amp & transformer.



First make sure the connectors are properly aligned



Gently but firmly press the connectors together till they are fully mated.

Transformer to Low Voltage Supply (Mains) PCB



Found towards the front of the transformer & the top rear of the Mains PCB.

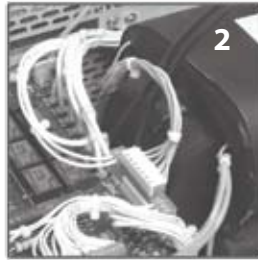

First make sure the connectors are properly aligned



Gently but firmly press the connectors together till they are fully mated.

Transformer to High Voltage Supply (HV) PCB

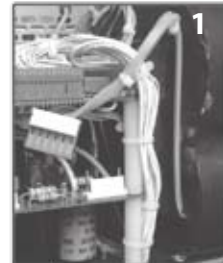

Found towards the front of the transformer & the lower side of the HV PCB.

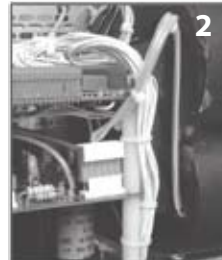

First make sure the connectors are properly aligned



Gently but firmly press the connectors together till they are fully mated.

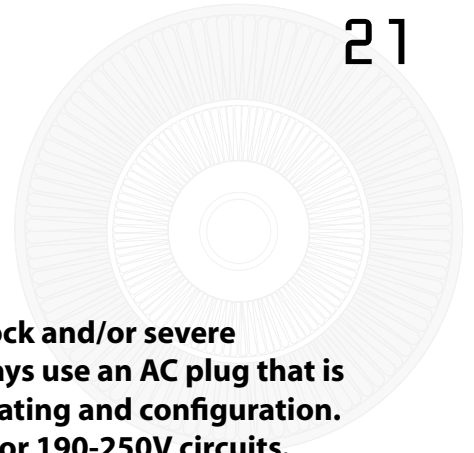

4.2.3 Power Cord Connections

WARNING!

To avoid the hazard of a potentially fatal electric shock and/or severe damage to the ALPHA 99 and other equipment, always use an AC plug that is appropriate for the primary mains voltage, current rating and configuration. NEVER use 120V-type plugs and power receptacles for 190-250V circuits.

ALWAYS use grounding type AC connectors which conform to local codes and ensure that the green wire in the Alpha 99 power cable is wired only to the AC mains safety ground (or to neutral, as may be necessary with a 240V circuit configured 120V-N-120V without a separate ground, commonly found in the US).

The green conductor in the power cord is wired to the ALPHA 99 chassis. It MUST be connected only to the power source safety ground or neutral. The black and white power cord wires connect to the two "hot" wires of the AC source; either wire may be connected to either side of the line. For best results use a dedicated 200-240 V branch circuit of #10 AWG copper wire or equivalent, rated at 20 A, to feed the amplifier.

4.2.4 Important Information About Operation from 90-130V AC

Electrical power equipment will draw twice as much primary current from 120 V mains as from 240 V mains. Therefore, operating the ALPHA 99 on a typical 120 V/20 A household circuit without exceeding the 20 A circuit rating will limit maximum peak power output to about 600-1000 W. Maximum possible RF output power for any particular primary AC voltage and current capacity may be estimated as:

$$P_{O \text{ max}} = (V_{\text{LINE}} \times I_{\text{LINE}}) / 2.3$$

For example, if the Alpha 99 operates from a circuit that is capable of delivering 115 V AC at a maximum current of 20A, with no other loads connected to the circuit, maximum peak RF output possible without tripping the 20A breaker (or fuse) is approximately:

$$P_{O \text{ max}} = (115V \times 20A) / 2.3 = 2300/2.3 = 1000 \text{ W}$$

If the same circuit also supplies a transceiver drawing peak line current of 5A and a lamp drawing 1A, only 20-5-1 = 14A is available for the amplifier and maximum possible output is about:

$$P_{O \text{ max}} = (115V \times 14A) / 2.3 = 1610/2.3 = 700W$$

4.3 AC Primary Connections

Primary voltage is selected by placing a jumper wire on the proper pin located on the mains board seated between the transformer and the front panel of the amplifier. See Figures 4-2 and 4-3.

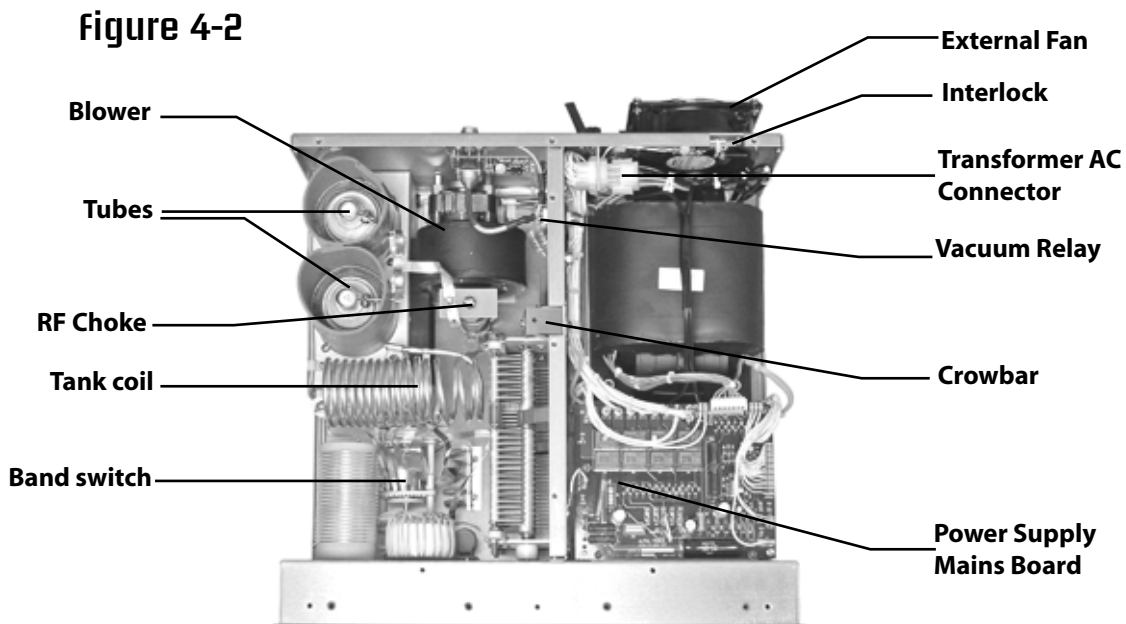

Below are some considerations at the high end and the low end of this voltage range that are rarely encountered.

Low Voltage vs. Power Output

At the low end of the voltage range, do not expect to be able to get 1,500 watts output if your line voltage is below 110 volts. If your line voltage is between 110 and 130 volts, then 1,500 watts PEP operation (CW or SSB) may be possible if your AC line service has sufficient current capacity (30 amp circuit recommended). However, 1,500 watts continuous should not be expected. If your line voltage is between 90-110 volts, then power outputs above 1,000 watts should not be expected from the amplifier. Tune (adjust) the amplifier for no more than 1,000 watts output, and simultaneously for maximum efficiency.

Low Voltage vs. Current Draw

If either of the two low voltage taps is used, be aware that the amplifier is normally shipped fused with 20A/250V fuses. You may want to consider replacing these with 25A/250V "slo-blo" fuses for very low line voltages (less than 100 volts). If you do, be aware that the higher current at the lower voltage will significantly warm the power cord for the amplifier. The cord (as well as fuse holders and some internal connectors) are operating near their maximum ratings due to the current demand at lower voltages. Be sure that the AC cord is not coiled too tightly or placed where normal air flow is restricted because the cord could overheat. If other equipment is drawing current from the same circuit as the Alpha 99, then the considerations in section 4.2.3 should be taken into account.

High Voltage and Tube Life

At the high end (sometimes encountered when using poorly regulated generators) the plate voltage and tube heater voltage may be too high. If voltages above 250 volts are applied for any length of time, the lifetime of the tubes may be reduced. If this is your situation, the first line of defense is to contact your utility company and ask if they can reduce your line voltage. If this is not possible, you may want to consider placing your own step-down transformer in line between the AC outlet and the amplifier. If this is necessary, a transformer with at least 4-kVA rating is required, due to the nature of the current waveform in the primary. Another choice for voltage control, a ferro-resonant voltage regulator, is an expensive solution, but is a good way to stabilize primary voltage.

Note: If you intend to operate the amplifier on any of the 90 - 130V settings, the two lower 2 amp fuses on the rear panel will have to be changed to 5 amp to allow for the increased in-rush current.

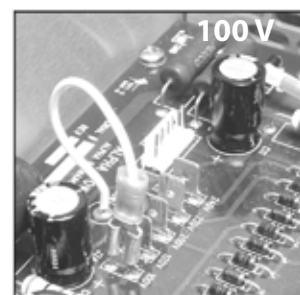
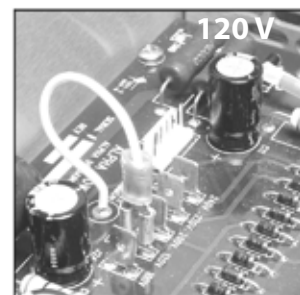
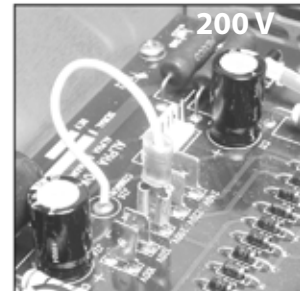
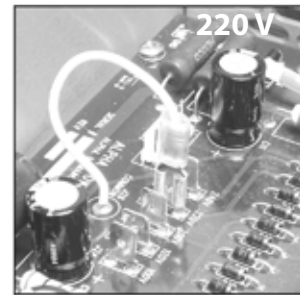
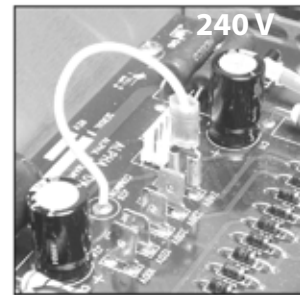
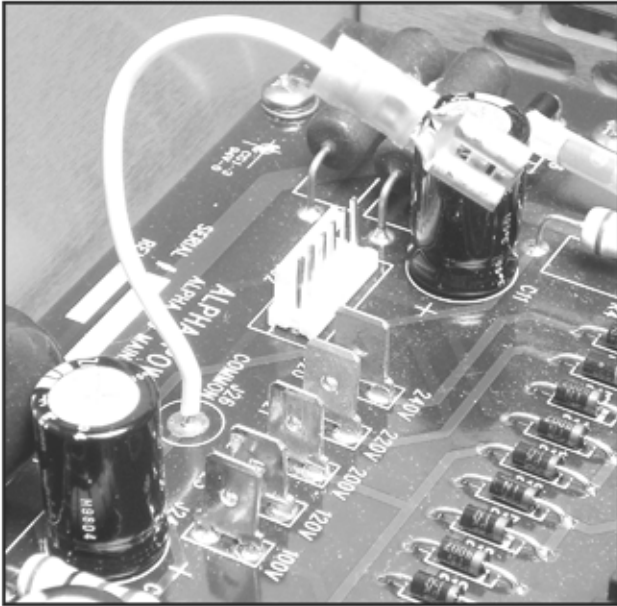
Figure 4-3 - AC Power setting

With the top cover removed, the primary voltage taps are located on the top of the Mains Board, which is between the transformer and the front panel. There is a row of 5 “fast on” connectors (J1 through J5) and a “flying” jumper connector which mates with them. See Figure 4-3. There are 5 “nominal” primary voltages, which cover all the line voltages normally encountered around the world. Selecting the appropriate tap for your situation will optimize amplifier performance, safety and lifetime. The nominal mid-range voltage for each tap is printed on the Mains Board circuit board. These voltages are 100, 120, 200, 220 and 240 Volts. The acceptable line voltage for each tap is the center voltage plus or minus 10 Volts. One of these taps is suitable for any of the “nominal” line voltages encountered worldwide.

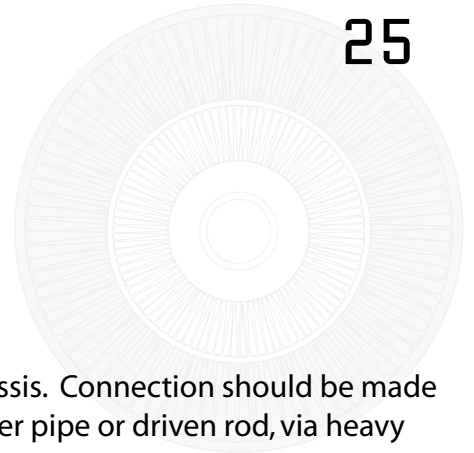

4.4 Complete the Transformer Installation

4.4.1 RF Grounding

A ground stud with wing nut is provided on the rear of the chassis. Connection should be made from this stud to a good RF earth ground, such as a copper water pipe or driven rod, via heavy copper braid or strap.

CAUTION:

When using any high power amplifier, failure to connect ALL station equipment to a good common ground may allow RF feedback to leak into the transceiver and cause severe signal distortion.

4.4.2 Replacing the Amplifier Cover

Replace all attachment screws. Use only the 6-32 screws supplied with the amplifier and do not tighten any of the screws until all are started. Do not attempt to operate the amplifier with the cover removed or only placed back on the unit without the attachment screws. This WILL cause damage to the Alpha 99 and may also lead to injury or death to the operator.

4.4.3 Blower Preparation

The cooling fan is secured to the rear panel for shipping. Be sure to remove the fan shipping hardware (two 10-32 bolts, fiber washers, rubber shim) from rear chassis wall. Save this hardware! It must be reinstalled whenever the chassis is transported.

4.5 Amplifier/Station Interconnections

Once the power transformer is installed, properly configured, and the cover replaced, place the amplifier in its operating position. The amplifier with the transformer installed is heavy so you may need assistance to safely move it. Make sure it is placed on a stable surface and that there is sufficient space to the rear, sides, and top to allow good air flow and safe placement of cables.

4.5.1 Coaxial Cable Types & Connectors

Connect the transceiver RF output to the ALPHA 99 RF INPUT connector with 50-ohm coaxial cable- RG-

58C/U or equivalent. A 6 ft. cable is supplied for this purpose.

Coaxial cable from the 99 RF OUTPUT connector to the antenna should be RG-8A/U, RG-213/U, or equivalent high quality type with a PL-259 UHF-type plug on the amplifier end. RG8X cable is not recommended, as it is not rated for 1500 watts.

4.5.2 T/R Control Cable

The Alpha 99 has a full break-in vacuum relay QSK system requiring only the normal interconnection when used with a modern QSK transceiver. The Alpha 99 requires a contact closure (short circuit) on transmit from its RELAY jack center pin to chassis. This function is supplied by the transceiver, usually from a dedicated relay that is normally open in receive and closed in transmit. Shielded wire should be used for the T/R control cable. The Alpha 99 end must be fitted with a common phono (RCA-type) plug and the other end with a connector suitable for the transceiver.

The T/R relay contact must close before application of RF drive. The Alpha 99 protection circuitry prevents "hot-switching" with RF drive applied. Modern transceivers have the proper time delay between key up and the start of the transmitted signal to allow the Alpha 99 to follow the CW keying. If a T/R timing problem is suspected, connect the CW keyer to the RELAY jack on the Alpha 99, and connect a cable from KEY OUT on the amplifier to the keying input of the transmitter.

4.5.3 ALC

Alpha Radio Products does not recommend connecting the ALC on your Alpha 99 to your exciter.

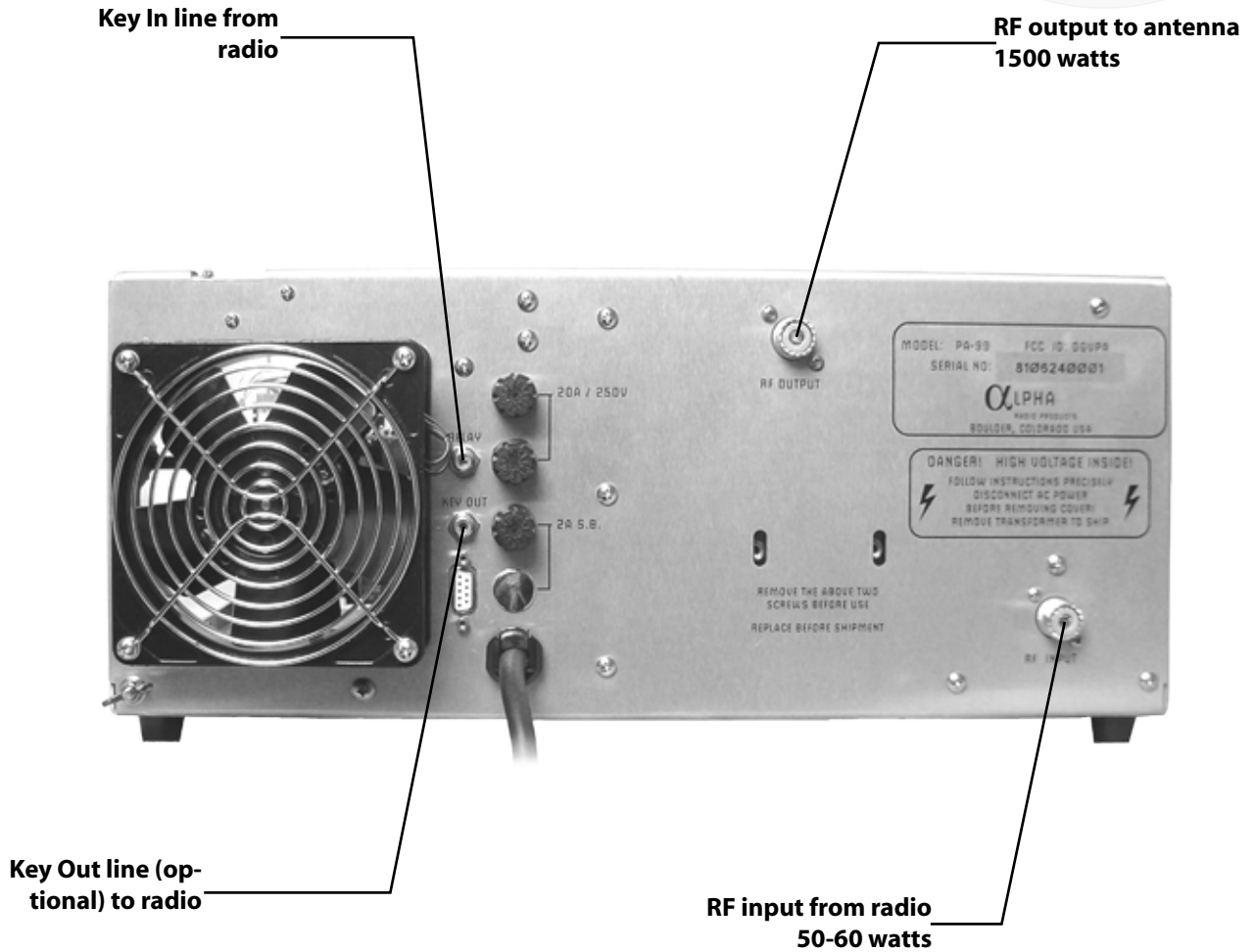
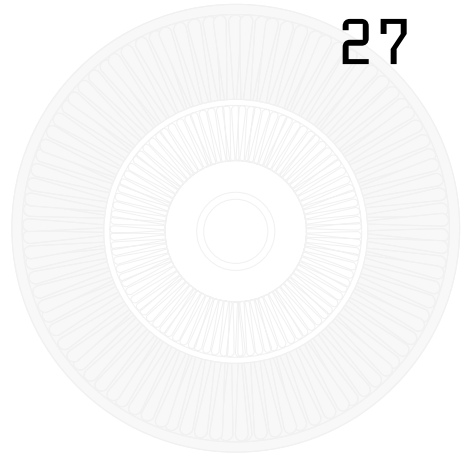

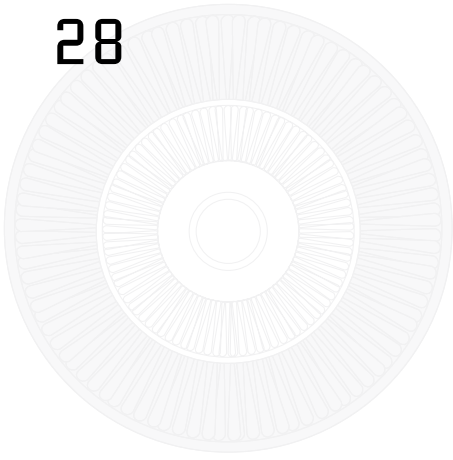

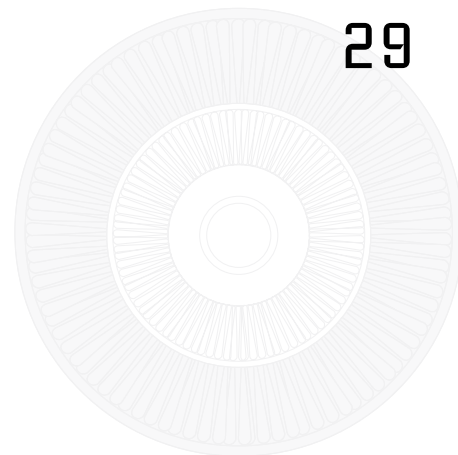

5 Theory of Operation

5.1 Theory of Operation - Overview

The Alpha 99 uses tetrode vacuum power grid tubes as the amplifying devices. The main power supply is an unregulated transformer/rectifier/capacitor power supply for the high voltage (HV) and heater circuits. All other power supplies are regulated. There are 8 circuit cards in the amplifier. In addition to these, the tubes, tank circuit assembly, and transformer complete the main sections of the amplifier. These major blocks are described below.

5.2 Tubes

The amplifier is designed to use two GU74B tetrode tubes. The Svetlana Company of St. Petersburg, Russia manufactures these tubes. The amplifier design uses these tubes well within their ratings. At the time of manufacture, these tubes are available as “new military surplus” (NMS) devices. According to Svetlana, the 4CX800A tube is a direct commercial replacement for the GU74B. The two tubes are operated in parallel, and the Alpha 99 is designed with the expectation that a matched pair of tubes will be used in the amplifier. Alpha matches tubes received from the supplier to within 10% for power output and gain when operated in a standardized test fixture. Note that power output, efficiency, tube life and amplifier reliability may be compromised if tubes are used that do not meet Alpha’s matching criteria. Any damage sustained as a result of using unmatched tubes may not be covered under warranty. The tubes are operated in Class AB1, with a plate voltage of 2,500V (nominal, full output, key down), a grid 1 voltage of 50-60 volts, and a grid 2 voltage of 340-360 volts. Each tube has a 15-ohm low-inductance resistor in series with its cathode. This resistor stabilizes the tube bias and provides negative feedback, which improves linearity (and hence IM performance). Electronic bias switching (EBS) increases the negative grid 1 voltage in pauses in speech or between Morse code elements. This reduces the standing bias on the tubes, resulting in less waste heat, longer tube life and higher overall amplifier efficiency. The artifacts of EBS are not noticeable under normal communications conditions.

5.3 Output Tank Circuit

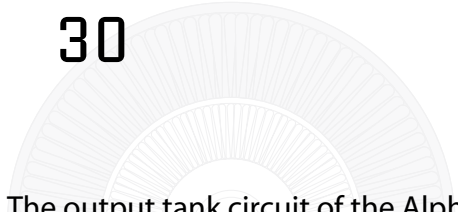

The output tank circuit of the Alpha 99 is designed to provide reliable high efficiency, low distortion performance in a very compact volume. The basic topology is “pi-L,” which provides harmonic attenuation adequate to meet the requirements of all countries globally that permit power outputs of 1,500 watts. Band switching is under manual control and is accomplished by a four-wafer band switch. Three of these wafers are used as multi-function tap selectors, which simultaneously select band taps on the inductors and include varying amounts of capacitance to provide band-spread on the tune and load capacitors. These three wafers are in the RF tank area. The fourth wafer is inside the front sub-chassis and is used by the control board to determine which band the user has selected.

5.4 Tube Deck

The tube deck is a mechanical assembly built around the tube deck PCB. The tube deck PCB has the tube sockets mounted on it, as well as those critical circuit elements that need to be in close proximity to the tubes. The tube sockets contain integral screen grid (grid 2) RF bypass capacitors. Also on this PCB is the input bypass relay. This relay is under microprocessor control and in one position switches the input RF to the tubes and in the other it switches the input RF to the tube matching circuit. The tubes are operated as a “swamped grid” tetrode design. The tube grids are tied at RF to a 50-ohm swamping resistor, which absorbs most of the input drive power. The RF voltage across this resistor is added to the grid 1 DC bias to provide the net low-impedance tube grid 1 bias. The RF impedance represented by grid 1 and its capacitance is compensated for by a series inductance to provide less than 2:1 SWR on each band at the amplifier’s input. At higher frequencies, a relay shorts out some of this compensating inductance. This relay is under microprocessor control and is actuated according to the band switch setting.

5.5 Mains Board

The power supply functions are split between the mains board and the high voltage (HV) board. The mains board mostly deals with the primary side of the transformer. The various taps for the transformer primary are routed through this board and so is the AC line input. Relays on the mains board connect the AC line to the appropriate taps on the primary. One of 5 tap options is selected by using a 5-way jumper field. See section 4.3 for more details on how to set the jumper. Also on the mains board is a step-start circuit. This circuit consists of a relay and a resistor, which are time-sequenced to limit the inrush current into the amplifier when it is first turned on. When initially turned on, the tap relays operate from a voltage derived from resistors from the AC line. They hold via contacts on the trip relay on the HV board. The regulated minus 12 volt and minus 124 volt supplies are also located on this board.

5.6 High Voltage Board

The main high voltage for the amplifier is created on this board using a full-wave bridge rectifier and a bank of capacitors. This power supply has two 10-ohm resistors, one in the positive (B+) lead, and the other in the negative return, which goes to ground. The combination of these two resistors limits the surge current in the case of a B+ arc. The voltage across the resistor in the negative return is used to monitor tube plate current in the control board. This voltage is also used to generate the "hard fault" condition. When the power supply current exceeds about 2 to 2.5 Amps, a relay operates to open the coil circuit of the mains tap relays on the mains board. When these relays release, the amplifier goes to the power-off state. This hard fault circuit operates independently of microprocessor control. The regulated screen supply is also located on this board. It consists of a string of Zener diodes and a series-pass N-channel MOSFET. All power supply filter capacitors on this board have bleeder resistors which will discharge the capacitors in less than 60 seconds. If it is necessary to work on this board, it is nevertheless recommended that the discharged condition be confirmed with a voltmeter, due to the remote possibility of bleeder resistor failure.

5.7 Control Board

The control board is the heart of the amplifier. It contains all of the bias, control and safety circuitry for the Alpha 99. All tube bias conditions are set on this board, as well as transmit and receive timing. All critical safety parameters, such as plate current, amplifier gain and reflected power are monitored on this board. These parameters are set at the factory and there are no user adjustments recommended or desired.

5.8 Display Board

This board converts analog voltages into linear bar graph displays for the front panel. It receives these voltages from the control board. Various discrete LEDs are also on this board.

5.9 Output Wattmeter Board

This is a transformer-coupled reflectometer with diode detectors. The outputs from this board are DC voltages corresponding to the forward and reflected power sensed by the reflectometer. These voltages are connected to the control board. There is a trimmer capacitor on this board. This capacitor is adjusted with the amplifier operating into a good 50-ohm dummy load. The capacitor is rotated to minimize the reflected power voltage. The board also has an 800V protection device on the RF output. This is located between the PCB and the flange of the output connector.

5.10 Center Partition Board

This contains the RF decoupling circuit on the B+ line as well as the “crowbar” safety circuit. This safety device consists of a piece of spring metal, which shorts out the B+ line when the top cover of the amplifier is removed.

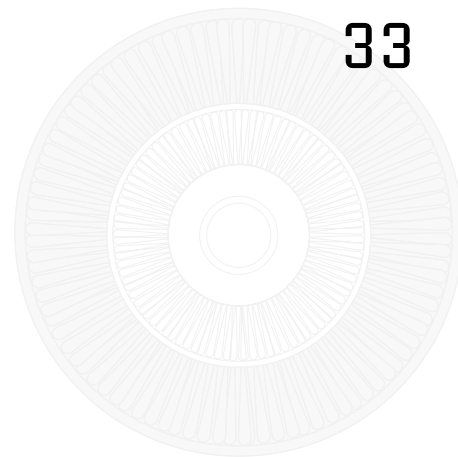

6 Operation & Maintenance

The ALPHA 99 is extremely easy to operate, but failure to carry out each procedure exactly as described in this manual is likely to lead to amplifier damage, which is not covered under warranty. Damage to other station equipment may also result.

6.1 Before Operating Your Alpha 99

6.1.1 Setting Input Drive

You must set the transceiver output power properly. Virtually all damage to date has resulted directly from severe overdrive. The ALPHA 99 requires about 50 W drive for full rated output. **Damage caused by applying several times rated drive power to the ALPHA 99 will not be covered under warranty.** Fortunately, most modern transceivers maintain quite consistent output from band-to-band and mode-to-mode when set up properly.

CAUTION:

Setting only the transceiver POWER or RF PWR control IS NOT SUFFICIENT. Several popular transceivers can generate RF spikes of 200-300 W. Control of these spikes typically is done with a knob labeled DRIVE (IC-781, FT-1000) or PROCESSOR OUT (TS-940, TS-950). On SSB, when speech processing is not used, adjust the MIC or MIKE controls. See the operator's manual for your particular transceiver.

6.1.2 Dealing with faults

The ALPHA 99 "faults" into STBY or OFF when unsafe operating conditions occur. This is shown when the amplifier changes from the OPR LED being ON to the Fault and STBY LEDs turning ON instead (soft fault), or when the amplifier shuts off completely (hard fault).

One of four situations will typically result in a fault:

- Incorrect gain. Output too low or too high for the input power supplied.
- High reflected power (SWR).
- Incorrect plate voltage (too high).
- RF arc in output circuit including antenna.

If the tube current exceeds about 2.5 amps, the amplifier is shut off completely- that is, the AC is shut off. The ON/OFF switch will need to be used to put the amplifier back on line. To avoid problems, wait at least 20 seconds after this occurs before attempting to put the amplifier back on line. If the amplifier trips again immediately, investigate and cure the problem before attempting to turn the amplifier on again.

Repeatedly hitting the ON switch when the amplifier trips out is likely to result in severe damage to components in the amplifier.

If a hard fault trips the amplifier all the way OFF, wait at least 20 seconds before turning the amplifier power on again.

If you are certain that you have taken care of the problem that caused the fault, you may turn the amplifier back to operate and proceed with use.

6.1.3 High SWR Considerations

On any frequency where your antenna VSWR exceeds 1.5:1, it's important to carefully tune the ALPHA 99 for a proper match. The ALPHA 99 does not contain an antenna tuner. The SWR can be tuned via the antenna or an external tuner connected to the output of the Alpha 99. Nevertheless, if the system SWR is below 2:1, the additional RF power loss of an antenna tuner can be avoided by tuning the 99 into the slight mismatch. There is no advantage to using a tuner to "tweak" the last bit of SWR - in fact you will lose power this way.

6.1.4 Operating at Less Than 1.5 kW Requires Retuning

If you tune the amplifier for maximum power output and then decide to operate the 99 at a power output much different from 1.5 kW, it must be re-tuned for efficient and RF-clean operation. Under such "lightly loaded" conditions, the green grid LED will probably be fully lit. Note that if you tune the amplifier at 1,500 watts and then simply reduce power to 1,000 watts, the tubes are actually going to run hotter than at 1,500 watts. It is better to tune the amplifier with close to 50 watts of power, but reduce the loading control to get 1,000 watts.

6.1.5 Lightning Protection

Induced energy from nearby electrical storms or other power transients may damage components. **Such damage is not covered under warranty.** It is important to use a good lightning arrestor, **however the only lightning proof solution available is to disconnect antenna feedlines and AC power when the equipment is not in use.**

6.1.6 Operating in Bypass Mode

Whenever the 99 is in line, either off, in standby (STBY), or in warm-up with the WAIT LED lighted, the amplifier is bypassed and the exciter is connected directly to the antenna. The throughput limit in all cases is 150 watts. Any power level more than this may damage the RF switching relays in the 99.

6.1.7 Never Use Transceiver Automatic Antenna Tuner

Never use an automatic antenna tuner into or through the 99. This will cause damage to the Input wattmeter and Input T/R Relay. Note that many popular transceivers have built-in antenna tuners that should be disengaged when driving your amplifier or transmitting through the amplifier with the amplifier in bypass mode.

6.2 Transceiver Connections

The following is a list of popular transceivers and considerations for their connection to the ALPHA 99 amplifier. Contact Alpha Radio Products Customer Service for advice on other transceivers.

Table 6.2 Typical Transceiver Connections

Transceiver	Connection and Keying Information
Icom	RF – T/R – Connection with the “Send” jack. See the transceiver User’s Manual for information.
Yeasu	RF – T/R – Connection with the RCA “TX GND” connector. Also with the DIN “Band Data” connector. See the transceiver User’s Manual for information.

Kenwood	RF – T/R – See the transceiver User’s Manual for information on connecting to external amplifiers.
Older Transceivers	See the transceiver User’s Manual for information on connecting to external amplifiers.

6.3 Initial Setup & Tuning

6.3.1 Control Functions

The following chart shows the controls that allow you to adjust and monitor the amplifier.

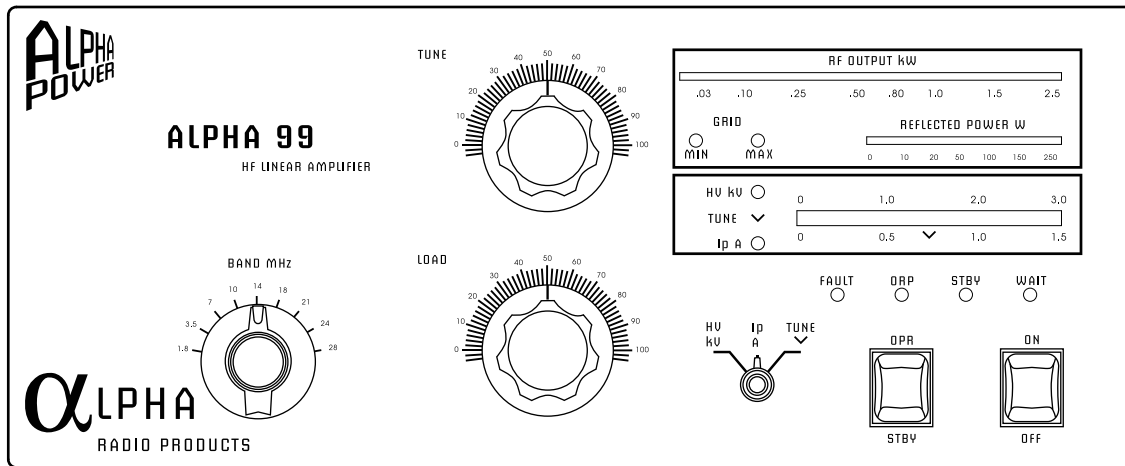

BAND	Used to select amateur band desired (in MHz).
TUNE	Sets output tank circuit to resonance within each band. Higher frequencies tend to tune toward the “0” end of the dial scale, while lower frequencies tend to tune further toward the “100” end.
LOAD	Sets amplifier plate loading and determines the power level at which best efficiency and linearity are achieved. In general, loading is heavier at greater scale settings. Higher frequencies tend to load more toward the “100” end of the dial scale and lower frequencies toward the “0” end.
POWER	Press ON to apply primary AC power to the amplifier or to reset power if the plate overcurrent relay has tripped. Press OFF to remove primary AC power.

OPR/STBY	Operate (OPR) places the amplifier in-line. With the 99 off, in standby(STBY), or in warm-up with the WAIT LED lighted, the amplifier is bypassed and the exciter is connected directly to the antenna.
Metering LEDs & Bargraphs	Separate bargraphs provide instantaneous full-time display of peak values.
RF OUTPUT & REFLECTED POWER	Red and green "GRID" LEDs indicate, respectively, that normal peak drive has been reached, and the onset of overdrive and flattopping. A switch-selected bargraph monitors three additional functions.
TUNE	Permits a simple and safe tune-up procedure to be performed at low output power. See section 6.3.2 Tune-Up.
Ip	Plate current, 1.5 amperes full scale (approximately 75 mA per segment).
HV	Plate voltage, 3000 VDC full scale (150 V per segment).

6.3.2 Tune-Up

The objective of tune-up is to adjust the amplifier (and the drive applied to it) to obtain optimum efficiency and linearity at the desired output power. Any linear amplifier must be adjusted for optimum efficiency and linearity at each specific power level. If operation at higher power is then attempted without appropriate readjustment, the result will be flattopping, "splatter," and (usually) excessive amplifier grid current. If operated at a much lower power level than it has been adjusted for, the amplifier's efficiency decreases considerably. Recommended practice is to tune first into a dummy load or artificial antenna, then connect the antenna and make any slight final adjustments that may be needed. Alpha Radio Products makes the ALPHA 2100 in-line dummy load which simplifies this process. Using the AP 2100, the operator can switch between the dummy load and the antenna at the flip of a switch.

6.3.3 Grid Current Information

The ALPHA 99 operates in Class AB2 when delivering maximum output power consistent with excellent linearity. A small amount of grid current flows and the green GRID MIN LED illuminates as drive approaches the optimum level. The green GRID LED will flicker on SSB voice peaks, and illuminate under CW/SSTV/RTTY carrier conditions.

As overdrive approaches, grid current increases rapidly and the red GRID MAX LED illuminates. At maximum output and efficiency, the red LED lights dimly; full illumination of the red LED indicates overdrive and must be avoided. If the red LED lights up before the desired value of plate current and/or power output is reached, readjust amplifier loading before continuing.

On SSB, optimum output consistent with good linearity occurs when the green GRID LED illuminates on most voice peaks and the red LED flickers dimly on only the highest peaks. Excessive grid current results from overdrive and/or inadequate loading. The solution is to reduce drive, and/or increase amplifier loading. The 99's 4CX800A/GU74b tubes are well protected and these adjustments tend to be less critical than in many other amplifiers. Grid bias is stabilized against grid current fluctuations.

6.3.4 ALC

The 99 grid current limiting circuits provide substantial tube protection against possible damage, therefore no ALC control is necessary. It is only necessary to set the drive power from the radio as detailed in this manual.

6.3.5 Turning On The Amplifier

Please Note: Every time the ALPHA 99 is powered up there is a built-in 150 second warm up wait.

1. Place the OPR/STBY switch to STBY (standby).
2. Rotate the multimeter selector switch to HV.
3. Depress the POWER/ON switch. For about two seconds the bar graph displays and the LEDs on the front panel will be lit randomly as the microcontroller goes through its start-up sequence. The fan and blower should immediately begin to operate. If there is no air flow from the amplifier and no sound of blower operation, immediately turn the amplifier off and investigate.
4. After the two-second period, the HV display should be all the way to the right, certainly above 2,500 Volts. If it is lower than this, investigate further- perhaps the primary taps are not correctly set.
5. Move the multimeter switch to the Ip position. There should be no current indicated, and this should be true during the entire period the amplifier is warming up. Leave the switch in the Ip position during amplifier warmup. The "Wait" LED will be blinking about twice per second, indicating that warmup is still in progress. The FAULT, OPER and STBY LEDs should not be illuminated.

CAUTION:

EXHAUST AIR MUST BE DETECTABLE FROM BOTH TOP VENTS.

If exhaust air is not coming from the top vents, TURN OFF the amplifier immediately and verify that the exhaust chimneys are properly positioned over the tubes. When the warm up delay is complete (about 150 seconds), the WAIT LED will extinguish. Put the OPR/STBY switch to OPR and

ALPHA 99 is now “ready”.

6.3.6 Tuning the Amplifier

Band (MHz)	Frequency (MHz)	Tune	Load
1.8	1.8	60	14
1.8	2.0	20	65
3.5	3.5	67	40
3.5	3.75	58	60
3.5	4.0	50	75
7	7.15	45	35
10	10.13	15	26
14	14.2	70	40
18	18.1	50	55
21	21.2	40	65
24	24.9	65	60
28	28.0	32	72
28	28.6	24	74
28	29.7	18	76

*Each ALPHA 99 shipped from our factory will include an individual table showing the tune and load settings we used to achieve full output power on that amplifier into an AP 2100, a 50-ohm dummy load. These settings usually vary slightly from those in the manual.

CAUTION:

If at any time in the following procedure the amplifier fails to respond as described, remove drive immediately and turn the OPR/STBY switch to STBY! Verify all connections and cables, turn the amplifier switch to OPR and proceed with the tuning procedure.

Alpha Radio Products recommended tune up procedure. “Dip and Load” Method

Tuning up for Operation at 1,500 W RF Output.

Preset BAND, TUNE, and LOAD controls to the nominal positions given in your amp's specific tune up table or Table 6.3:

Note: Final TUNE and LOAD settings will vary with the operating frequency, antenna characteristics and power level.

1. Please limit the transceiver drive to about 65W for tuning up and operating the amp.
2. Set Multimeter to Ip (Plate Current). Set TUNE and LOAD controls to numbers indicated in the tuneup sheet originally included with the amplifier.
3. Key radio with 20W drive and adjust TUNE control for a peak in RF out which should be at the same point as a dip in Ip.
4. Increase drive to get 1000W output, going back and forth between the TUNE and LOAD to peak the RF output. If more output is desired, increase drive from radio slightly, increase LOAD for a peak in RF out, then peak RF out with TUNE control.
5. When the amplifier is tuned correctly on 160m thru 40m, the Ip should range between 0.9A and 1.1 A (read on the 0-to-1.5A scale) for 1500W output, and input drive should not need to be more than about 60W. On 20m the Ip will usually be about 1.0A for 1500W output.
6. Plate current (Ip) is the most useful parameter to monitor on the multimeter bargraph during normal operation of the amplifier.

Alpha Radio Products alternate tune up procedure. “Nominal Gain” Method

Tuning up for Operation at 1,500 W RF Output.

Preset BAND, TUNE, and LOAD controls to the nominal positions given in your amp's specific tune up table or Table 6.3:

Note: Final TUNE and LOAD settings will vary with the operating frequency, antenna characteristics and power level.

1. Reduce transceiver carrier output control to ZERO.
2. Press OPR (operate) on OPR-STBY switch. OPR LED should illuminate.
3. Select the TUNE function of the multimeter bargraph.
4. Switch transceiver to CW and increase its carrier output to approximately 15 W (99 output will be approximately 300-500 W).
5. Adjust the TUNE control to deflect the TUNE LED maximum rightward.
6. Adjust the LOAD control to place the illuminated TUNE LED near the "V" mark on the TUNE scale.
7. Repeat steps 5 and 6 at least twice.
8. Increase the excitation power until the 99 output is about 1500 W.
9. Repeat steps 6 and 7 at least twice.
10. Touch up the TUNE for maximum power output.
11. The ALPHA 99 is now correctly tuned to deliver 1500 W RF output on SSB, CW, FSK, SSTV and FM. The TUNE LED normally fluctuates during modulation or keying. Illumination of the first red LED on the RF OUTPUT bargraph indicates output has exceeded 1500 W. The tune LED may vary during standard operation, especially SSB. This is normal.

6.4 Normal Use

6.4.1 Tubes

The 4CX800A/GU74b tubes used in the ALPHA 99 are supplied as a matched pair. They are very rugged and normally operate with a large margin of safety. They should provide outstanding service for many years if not damaged by abuse - such as overdrive or blockage of cooling airflow.

Allow at least three to four inches (10 cm) of unobstructed clearance around the air intake and exhaust areas. Stacking equipment on top of the amplifier is not recommended.

Never allow key-down plate current to exceed 1.5 A for more than one or two seconds. If you do, and a plate current trip occurs, it will automatically reset in about 4 seconds if the amplifier is returned to receive (key-up).

Never allow the red GRID LED to stay brightly illuminated for more than a second.

Frequent on-off AC power cycling may shorten the tubes' life. It is less stressful to leave equipment in standby for several hours than to cycle power repeatedly on-off-on-off over the same period.

6.4.2 Interlocks

The ALPHA 99 is equipped with a cover interlock switch intended to remove primary power from the amplifier, and a crowbar to short-circuit the high voltage to chassis whenever the cover is lifted. These interlocks are designed to protect against dangerous electric shock resulting from accidental contact with the lethal voltages inside the amplifier.

WARNING!

ALWAYS DISCONNECT THE AC LINE CORD FROM THE POWER SOURCE BEFORE REMOVING THE TOP COVER FROM THE 99 FOR ANY REASON!

Cover interlocks are intended only as back-up protection against accidents. Never depend on them! Always disconnect the power cord from the AC mains before removing the cover! Interlock switches should not be disabled for any reason.

6.4.3 Fuses

Never replace any fuse with one of a different type or greater current rating. Blowing of one or both primary line fuses indicates that the maximum safe average power capability of the amplifier has been substantially exceeded or that an equipment failure has occurred. USE ONLY 20 AMP, 250 VOLT RATED FUSES for 190-220 VAC service. 25 amp fuses may be used with caution for line voltages of 90-130V.

The slow-blow fuse F3, located below the primary line fuses, may prevent damage to the step-start resistors and HV rectifiers in the event of abnormal turn-on conditions or HV faults. If the AC interlock is defeated and primary power is applied while the HV crowbar is closed, the step-start

fuses will normally blow.

CAUTION:

DAMAGE RESULTING FROM USE OF A FUSE OF INCORRECT SIZE OR TYPE WILL NOT BE COVERED UNDER WARRANTY AND MAY VOID THE WARRANTY.

6.4.4 Plate Overcurrent Relay

This relay will quickly turn off the amplifier in the event of grossly excessive plate current or fault in the high voltage circuitry. The relay will not prevent tube or other damage due to either short or long term overdrive or improper tuning. It is the operator's responsibility to ensure safe tuning, drive, and general operating conditions. Should the overcurrent relay trip, remove AC power from the amplifier, then determine and correct the cause of the trip before turning the 99 on again. This "hard fault" trip circuit does not rely on the microcontroller for its operation, and will protect the amplifier even if the processor has been damaged or is malfunctioning.

6.4.5 Idling Plate Current and Electronic Bias Control (EBC)

Idling plate current of the ALPHA 99 is approximately 350 to 400 mA during full power transmission. A detector senses RF drive, and reduces plate current to 30-50 mA during pauses in speech and key-up intervals, thus substantially reducing average power supply loading, heat generation, and wasted energy.

6.4.6 RF and Mistuning Protection

The ALPHA 99's exclusive circuit senses the beginning of any RF arc in, for example, a TUNE or LOAD variable capacitor and automatically switches the amplifier to standby within a few milliseconds. This system has virtually eliminated RF arc damage in current ALPHA amplifiers. The system similarly detects severe miss-tuning of the 99, and if drive exceeds about 25 W switches the amplifier to standby. The 25 watt input trip threshold permits safe tune-up at low power levels without aggravating and unnecessary trip-outs.

6.5 Standard Maintenance Tasks

The amplifier interior, particularly high voltage areas, should be cleaned with a vacuum cleaner and a soft bristle brush frequently enough to prevent visible accumulation of dust. In extremely dusty conditions it may be advisable to secure a thin air filter of the type used for window air conditioners across the air intake on the rear panel.

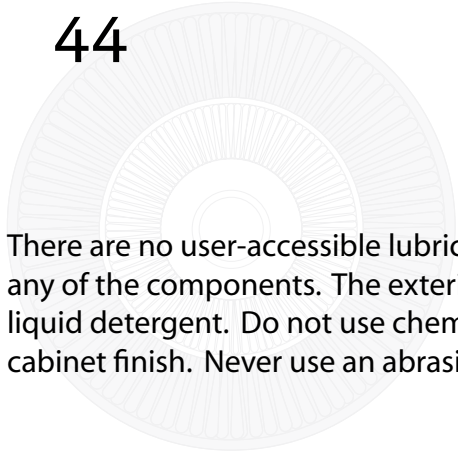

There are no user-accessible lubrication points in the amplifier. Do not apply oil or grease to any of the components. The exterior of the ALPHA 99 may be cleaned with a mild household liquid detergent. Do not use chemical solvents, as these may severely damage the front panel or cabinet finish. Never use an abrasive cleaner.

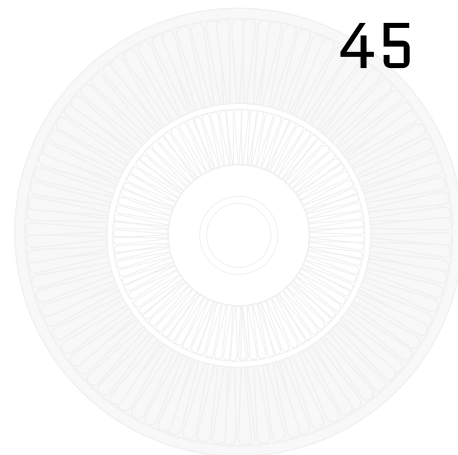

7 Troubleshooting Hints

7.1 Normal Troubleshooting

99 will not turn on; nothing happens when ON switch is pushed.

Problem	Correction
1) External AC wiring, fuse or circuit breaker may be open.	Check & correct wiring, replace fuse, or reset circuit breaker.
2) Amplifier cover is not in place or properly secured; cover safety interlock is open.	Make sure cover is replaced and all screws securely inserted.
3) Fuse F1-F4 open or missing. Check fuses with an ohmmeter.	Check and replace any blown fuses with fuses of the same size.
4) Step-start resistor open.	Check resistor. If damaged, replace.

Amplifier turns on but no HV is indicated by the multimeter LED bargraph.

Problem	Correction
1) Multimeter selector switch in wrong position, e.g., Ip.	Set Multimeter switch to the correct position.
2) Possible HV circuit fault.	
3) HV sampling resistor in power supply damaged.	
4) Transformer plugged into power supply incorrectly.	Check power supply wiring and connectors to be sure input and output connectors are set properly and the voltage taps have been set properly.

Amplifier turns on but no multimeter indication; other LED bargraphs are operative.

Problem	Correction
1) Low voltage power supply problem.	
2) Defect or damage on control board.	

Amplifier turns on but time delay will not complete; WAIT LED does not turn off.

Problem	Correction
1) Defect or damage in timing circuitry on control board.	Contact Alpha Customer Service.

Amplifier turns on, time delay completes but amplifier will not transmit.

Problem	Correction
1) Open T/R control line from transceiver to RELAY jack.	Contact Alpha Customer Service.

Amplifier transmits but red GRID LED illuminates often.

Problem	Correction
1) Amplifier overdriven or under-loaded.	Reduce transceiver output and /or increase amplifier loading.
2) Load VSWR (reflected power) exceeds 200 W.	Check output cabling and antenna. Correct impedance mismatches.
3) Exciter output poorly controlled.	Consult exciter's User's Manual for assistance on controlling output.

Amplifier operates but green GRID LED will not light and plate current is low; transceiver does not seem to be able to drive amplifier to its rated RF output power level.

Problem	Correction
1) Input RF load resistor or bias circuitry damaged.	Contact Alpha Customer Service.

2) Possible damaged or defective tube(s).	Contact Alpha Customer Service.
---	---------------------------------

Receive signals disappear or are severely attenuated when switching from STBY to OPR.

Problem	Correction
1) RELAY (T/R) control cable from transceiver is shorted.	Check T/R control cable to make sure it is switching properly. Replace if needed.
2) Transceiver locked in transmit	Make sure transceiver is properly switching between transmit and receive. See transceiver's User's Manual for assistance.

Plate current indicated when amplifier is in STBY or receive.

Problem	Correction
1) 4CX800A/GU74b tube heater-to-cathode leakage or short.	Contact Alpha Customer Support.
2) Tube bias supply or T/R bias switch faulty.	Contact Alpha Customer Support.

Distorted SSB signal; possible severe television interference.

Problem	Correction
1) Excessive RF drive from transceiver and/or insufficient amplifier loading.	Decrease drive from transceiver. Re-check amplifier tuning.
2) Coaxial connector, coax feedline, antenna feedpoint balun, tuner, or antenna trap arcing on voice peaks.	
3) RF feedback from antenna into transceiver via the transceiver power cord, microphone or key cable, or other unshielded station patch cables.	Make sure all power cords, microphone and key cables, or other cables are properly shielded and grounded.
4) Poor station RF ground.	Be sure the amplifier and transceiver have a proper RF ground. Correct if necessary.

Low frequency (60 Hz) audio hum on transmitted signal.

Problem	Correction
1) Defective microphone cord (especially, a broken ground lead).	Check to be sure microphone cord has not broken or does not have defective leads or connectors.
2) Dynamic (magnetic) microphone located within about two feet of 99 power transformer.	All dynamic microphones pick up some magnetically coupled hum from the external field of nearby power transformers. In cases where objectionable hum is experienced while using the 99 and popular microphones such as the Heil series, the problem usually can be resolved by keeping the microphone at least 18 to 24 inches from the front of the amplifier and ensuring that transceiver mike gain and speech processing levels are not adjusted to exceed 10 dB. In rare cases it may be necessary to use a ceramic or condenser type microphone.

Grid bias is unexpectedly decreasing.

Problem	Correction
1) Nominal grid bias current is 380 mA. If the normal bias is decreasing, the tubes are probably aging.	Contact Alpha Customer Support to see if tubes need replacing.

Required drive to maintain 1,500 W is steadily increasing.

Problem	Correction
1) If the amount of drive required to maintain 1,500 watts is steadily increasing, this is an indication that the tubes are probably aging.	Contact Alpha Customer Support to see if tubes need replacing.

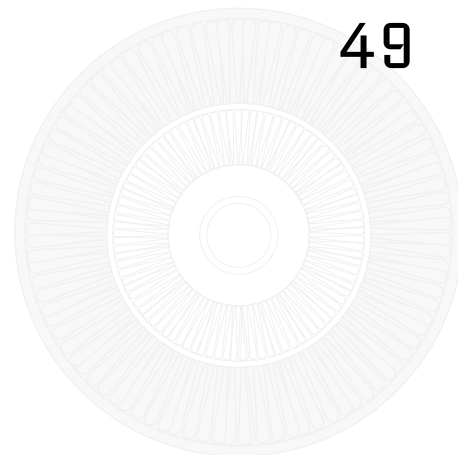

8 Glossary

The following terms are used in this manual. Detailed explanations may be found in various publications including the ARRL Handbook.

AB1-	Modulation class AB1. Provides good linearity in push-pull configuration.
AC-	Alternating current
ALC-	Automatic Level Control
ampere-	Current measurement
ARRL-	American Radio Relay League
AWG-	American wire gauge
CW-	Continuous wave
dB-	Decibel
EBS-	Electronic bias control
Exciter-	The radio that provides RF drive for the 99 to operate
FCC-	Federal Communications Commission
FM-	Frequency modulation
FSK-	Frequency-shift keying
HF-	High frequency (3 to 30 MHz)
HV-	High voltage
Hz-	Hertz
Ip-	Idling plate current
kV-	Kilovolts
kVA-	Kilovolts/ampere. $kVA * 0.8 = \text{kilowatts}$
kW-	Kilowatt
LED-	Light-emitting diode
LV-	Low voltage
mA-	Milliampere
MHz-	Megahertz
OPR-	Operate
PSK-	Phase shift keying. A digital modulation scheme
QSK-	Quadrature shift keying. In this CW transmitting mode, the transmitter is only on for the duration of each dot or dash and switches to receive between each

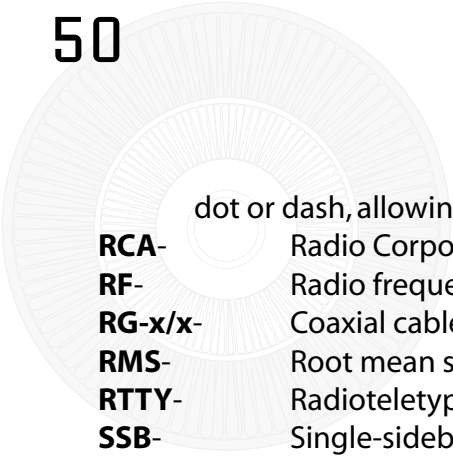

dot or dash, allowing the operator to hear any signal being sent.

RCA-	Radio Corporation of America. Also a type of interconnecting plug.
RF-	Radio frequency
RG-x/x-	Coaxial cable type
RMS-	Root mean square
RTTY-	Radioteletype
SSB-	Single-sideband
SSTV-	Slow-scan television
STBY-	Standby
SWR-	Standing wave ratio. A measure of antenna and feedline efficiency.
T/R-	Transmit / Receive
UHF-	Ultra high frequency (300-3,000 MHz)
US-	United States
VAC-	Volts of alternating current
VDC-	Volts of direct current
VSWR-	Voltage standing wave ratio