

PARTS LIST

Check each part against the following list. The key numbers correspond to the numbers on the Parts Pictorial (Illustration Booklet Pages 1, 2, and 3).

To order a replacement part, always include the Part Number and use the Parts Order Form furnished with

this kit. If a Parts Order Form is not available, refer to "Replacement Parts" at the rear of this Manual. Your Warranty is inside the front cover. For prices, refer to the separate "Heath Parts Price List."

KEY No.	HEATH Part No.	QTY.	DESCRIPTION	CIRCUIT Comp. No.
RESISTORS				
1/4-Watt				
A1	6-2151-12	1	2150 Ω (red-brown-green-brown)	R10
A1	6-8871-12	1	8870 Ω (gray-gray-violet-brown)	R2
1/2-Watt				
A2	6-621	1	620 Ω (blue-red-brown)	R9
A2	6-102	1	1000 Ω (brown-black-red)	R25
A2	6-222	2	2200 Ω (red-red-red)	R21, R22
A2	6-472	1	4700 Ω (yellow-violet-red)	R31
A2	6-203	1	20 k Ω (red-black-orange)	R28
A2	6-273	3	27 k Ω (red-violet-orange)	R4, R5, R11
A2	6-473	2	47 k Ω (yellow-violet-orange)	R23, R29
A2	6-104	1	100 k Ω (brown-black-yellow)	R27
Other Resistors				
A3	1-8-1	1	68 k Ω , 1-watt (blue-gray-orange)	R24
A3	1-38-1	3	4.7 M Ω , 1-watt (yellow-violet-green)	R6, R7, R8
A3	3-1-2	1	.82 Ω , 2-watt, 1% (gray-red-silver) (same size as 1-watt)	R3
A4	3-25-5	1	1 Ω , 5-watt, 1% wire-wound	R1
A5	5-2-7	8	30 k Ω , 7-watt film	R12 through R19

KEY No.	HEATH Part No.	QTY.	DESCRIPTION	CIRCUIT Comp. No.
CAPACITORS				
Mica				
B1	20-105	1	180 pF	C33
B1	20-124	7	115 pF	C16, C19, C26, C27, C28, C31, C58
B1	20-189	1	140 pF	C55
B1	20-108	1	200 pF	C56
B1	20-120	1	220 pF	C34
B1	20-139	1	330 pF	C57
B1	20-116	2	400 pF	C35, C39
B1	20-113	2	470 pF	C36, C38
B1	20-711	1	500 pF, 2KV	C62
B1	20-184	2	680 pF	C37, C41
Ceramic				
B2	21-79	1	.001 μ F, 6 KV	C7
B3	21-723	1	15 pF	C48
B3	21-140	2	.001 μ F, 500-volt (.001 M)	C47, C49
B3	21-70	1	.01 μ F	C32
B3	21-31	10	.02 μ F	C3, C5, C8, C21, C22, C23, C51, C52, C53, C54
B3	21-72	2	.005 μ F*	C1, C2

* These parts are critical for continued safety. Replace them only with parts of the same rating or with the proper Heath parts.

KEY No.	HEATH Part No.	QTY.	DESCRIPTION	CIRCUIT Comp. No.
---------	----------------	------	-------------	-------------------

Other Capacitors

B4	21-165	2	.001 μ F (1000 PF), 6 KV ceramic	C6, C29
B5	25-19	1	20 μ F (20 MFD) elec- trolytic	C4
B6	25-224	8	200 μ F (200 MFD) elec- trolytic	C10 through C17
B7	26-145	1	Load capacitor	C61
B8	26-164	1	Tune capacitor	C59

CONTROLS — SWITCHES

C1	61-45	2	DPDT switch	SW1, SW2
C2	61-46	1	SPDT switch	SW5
C3	63-1399	1	4-position rotary switch	SW3
C4	63-1338	1	4-position rotary switch	SW4A
C5	63-562	1	Rotary switch wafer	SW4B
C6	65-28	2	Circuit breaker	CB1, CB2
C7	69-55	1	TPDT relay	K1

COILS — CHOKES — TRANSFORMERS

D1	40-1666	1	80/20 plate coil	L5
D2	40-2117	1	15-meter input coil	L8
D2	40-964	1	15-meter input coil	L7
D2	40-965	2	20-meter input coil	L1, L6
D2	40-966	1	40-meter input coil	L2
D2	40-1012	1	80-meter input coil	L3
D3	40-1950	1	Plate coil	L4
D4	45-53	2	Parasitic choke	PC1, PC2
D5	45-4	3	1 mH RF choke	RFC4, RFC5, RFC6
D6	45-6	1	8.5 mH RF choke	RFC2
D7	45-78	1	10.3 μ H RF choke	RFC3
D8	45-61	1	50 μ H RF choke	RFC1
D9	54-237	1	High-voltage transformer (packaged separately)	T1
D9	54-238	1	Low-voltage transformer	T2

DIODES — TUBES

E1	56-24	1	1N458 diode	D18
E1	56-26	1	1N191 diode (brown-white- brown)	D17
E1	57-27	15	1N2071 diode	D1 through D14, D16
E2	56-82	1	1N3996A diode with hardware	ZD1
E3	411-245	2	3-500Z tube	V1, V2

KEY No.	HEATH Part No.	QTY.	DESCRIPTION
---------	----------------	------	-------------

METAL PARTS

F1	90-1303-1	1	Cabinet top
F2	90-1304-1	1	Cabinet bottom
F3	200-1435	1	Chassis
F4	100-1022	1	Capacitor bank bracket
F5	206-1444	1	Coil shield
F6	203-2147-1	1	Front panel
F7	203-2148-1	1	Rear panel
F8	203-2149	1	Left side panel
F9	203-2150	1	Right side panel
F10	204-1041	2	Angle bracket
F11	204-2102	1	Plate coil bracket
F12	205-723	1	Top rear plate cover
F13	205-724	1	Perforated top cover
F14	205-1794	2	Transformer mounting plate
F15	205-1780	1	Rectangular spacer
F16	206-493	1	RF shield
F17	258-115	1	5/8" \times 3-1/2" brass spring
F18	260-12	2	Plate connector
F19	456-7	1	Shaft coupler

PLASTIC PARTS

G1	255-59	2	Black tapered spacer
G2	261-9	4	Foot
	266-296	1	Fan blade
G3	354-5	6	Cable tie
G4	453-135	1	Phenolic shaft

HARDWARE

NOTE: Hardware packets are marked to show the size of the hardware they contain (HDW #4, HDW #6, etc.). You may have to open more than one packet in this pack to locate all of the hardware of any one size (#6, for example).

#6 Hardware

H1	250-1282	1	6-32 \times 1/8" allen setscrew
H1	250-230	6	6-32 \times 3/16" allen setscrew
H2	250-138	10	6-32 \times 3/16" screw
H3	250-1325	23	6-32 \times 1/4" black screw
H4	250-1419	1	6-32 \times 1/4" black flat head screw
H5	250-1432	29	#6 \times 3/8" black sheet metal screw
H6	250-1280	15	6-32 \times 3/8" black screw
H7	250-1420	24	6-32 \times 3/8" black flat head screw
H8	250-1425	4	6-32 \times 1/2" black screw
H9	250-206	13	6-32 \times 11/16" screw
H10	250-40	2	6-32 \times 1-1/2" screw
H11	250-1284	2	6-32 \times 1-9/16" black screw
H12	250-47	1	6-32 \times 2" screw
H13	252-3	53	6-32 nut
H14	253-1	17	#6 fiber flat washer
H15	253-2	2	#6 fiber shoulder washer

Heathkit®

KEY HEATH QTY. DESCRIPTION
No. Part No.

Hardware (cont'd.)

H16	254-1	69	#6 lockwasher
H17	255-77	2	7/16" spacer
H18	255-103	1	6-32 × 5/16" metal spacer
H19	255-71	4	6-32 × 3/4" metal spacer
H20	255-21	3	6-32 × 7/8" metal spacer
H21	255-129	1	6-32 × 1-1/2" metal spacer
H22	259-1	22	#6 solder lug

#8 Hardware

J1	250-1436	4	8-32 × 3/8" black screw
J2	252-4	4	8-32 nut
J3	253-9	4	#8 flat washer
J4	254-2	5	#8 lockwasher
J5	255-66	1	8-32 × 1-3/8" spacer

#10 Hardware

J6	250-126	4	10-32 × 1/2" screw
J7	250-331	1	10-32 × 1" screw
J8	252-5	1	10-32 nut
J9	252-163	1	10-32 wing nut
J10	254-3	2	#10 lockwasher

Other Hardware

K1	207-8	2	Cable clamp
K2	250-213	8	4-40 × 5/16" screw
K3	252-15	8	4-40 nut
K4	252-7	2	Control nut
K5	252-32	1	Push-on nut
K6	253-10	2	Control flat washer
K7	253-42	1	1/2" flat washer
K8	253-19	5	3/4" flat washer
K9	254-5	2	Control lockwasher
K10	254-9	8	#4 lockwasher
K11	259-25	1	#10 double lug
K12	259-16	1	#10 spade lug
K13	259-24	1	Long solder lug

INSULATORS — GROMMETS — TERMINAL STRIPS — CONNECTORS

L1	71-2	1	Ceramic feedthrough insulator (disassembled in bag)
----	------	---	---

KEY HEATH QTY. DESCRIPTION
No. Part No.

Insulators — Grommets — Terminal Strips — Connectors (cont'd.)

L2	73-4	1	5/16" grommet
L3	73-3	3	1/2" grommet
L4	73-2	1	3/4" grommet
L5	75-123	1	Line cord strain relief
	75-124	1	6" × 4-1/2" paper insulator
L6	75-125	8	Capacitor mounting insulator
L7	255-39	1	6-32 × 1-1/4" phenolic spacer
L8	255-42	3	6-32 × 3/4" phenolic spacer
L9	431-14	1	2-lug terminal strip
L10	431-10	2	3-lug terminal strip
L11	431-39	1	Small 5-lug terminal strip
L12	431-42	1	Large 5-lug terminal strip
L13	431-20	1	6-lug terminal strip
L14	431-13	1	4-screw terminal strip
L15	431-82	1	3-lug terminal collar
L16	432-137	14	Push-on connector
L17	432-199	1	Wire nut
L18	432-862	6	Male connector pin
L19	432-982	6	Female connector pin
L20	432-1090	1	Socket shell
L21	432-1091	1	Plug shell
L22	434-42	2	Phono socket
L23	434-93	2	5-lug ceramic tube socket
L24	436-5	2	Coaxial jack

WIRE — CABLE — SLEEVING

89-40	1	Line cord
340-1	36"	Medium bare wire
340-4	5"	Large bare wire
343-2	42"	Coaxial cable, RG-58A/U
343-8	14"	Coaxial cable, RG-8/U
344-2	60"	Medium black stranded wire
344-7	84"	Large black stranded wire
344-13	13"	Blue hookup wire (thick insulation)
344-118	30"	Large red stranded wire
344-146	24"	Large white stranded wire
345-1	3-1/2"	Large metal braid
345-2	9"	Untinned braided wire
346-4	12"	Small black sleeving
346-20	24"	Large black (heat-shrinkable) sleeving
346-26	7"	Large clear sleeving
346-29	8-1/2"	Small clear sleeving



KEY No.	HEATH Part No.	QTY.	DESCRIPTION	CIRCUIT Comp. No.
---------	----------------	------	-------------	-------------------

Hookup Wire (small solid)

	344-50	54"	Black hookup wire	
	344-51	42"	Brown hookup wire	
	344-52	24"	Red hookup wire	
	344-53	18"	Orange hookup wire	
	344-54	24"	Yellow hookup wire	
	344-55	36"	Green hookup wire	
	344-56	30"	Blue hookup wire	

MISCELLANEOUS

	74-29	8"	Double-sided tape	
	85-344-2	1	Printed circuit board	
M1	352-13	1	Silicone grease	
M2	407-763	1	Plate current meter	M1
M3	407-764	1	Plate volt meter	M2
M4	412-31	1	Small lamp	PL1
M5	413-10	1	Red lens	
M6	413-43	1	Diffuser	
M7	420-621	1	Fan motor	

KEY No.	HEATH Part No.	QTY.	DESCRIPTION
---------	----------------	------	-------------

Miscellaneous (Cont'd.)

M8	462-1130	1	Small knob
M9	462-1155	3	Large knob
	489-1	1	Sandpaper
M10	490-5	1	Nut starter Solder

PRINTED MATERIAL

	390-147	1	"Danger High Voltage" label
	390-2532-1	1	FCC label
		1	Blue and white label
	597-260	1	Parts Order Form
		1	Assembly Manual (See title page for part number)

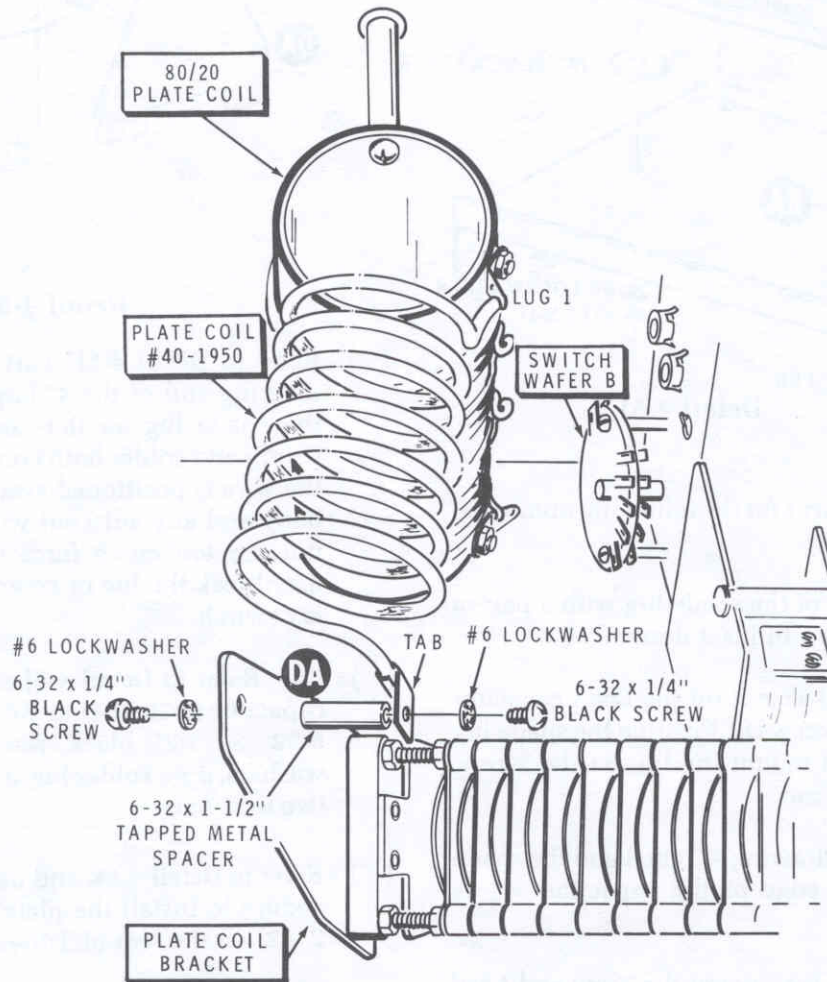

Detail 4-5L

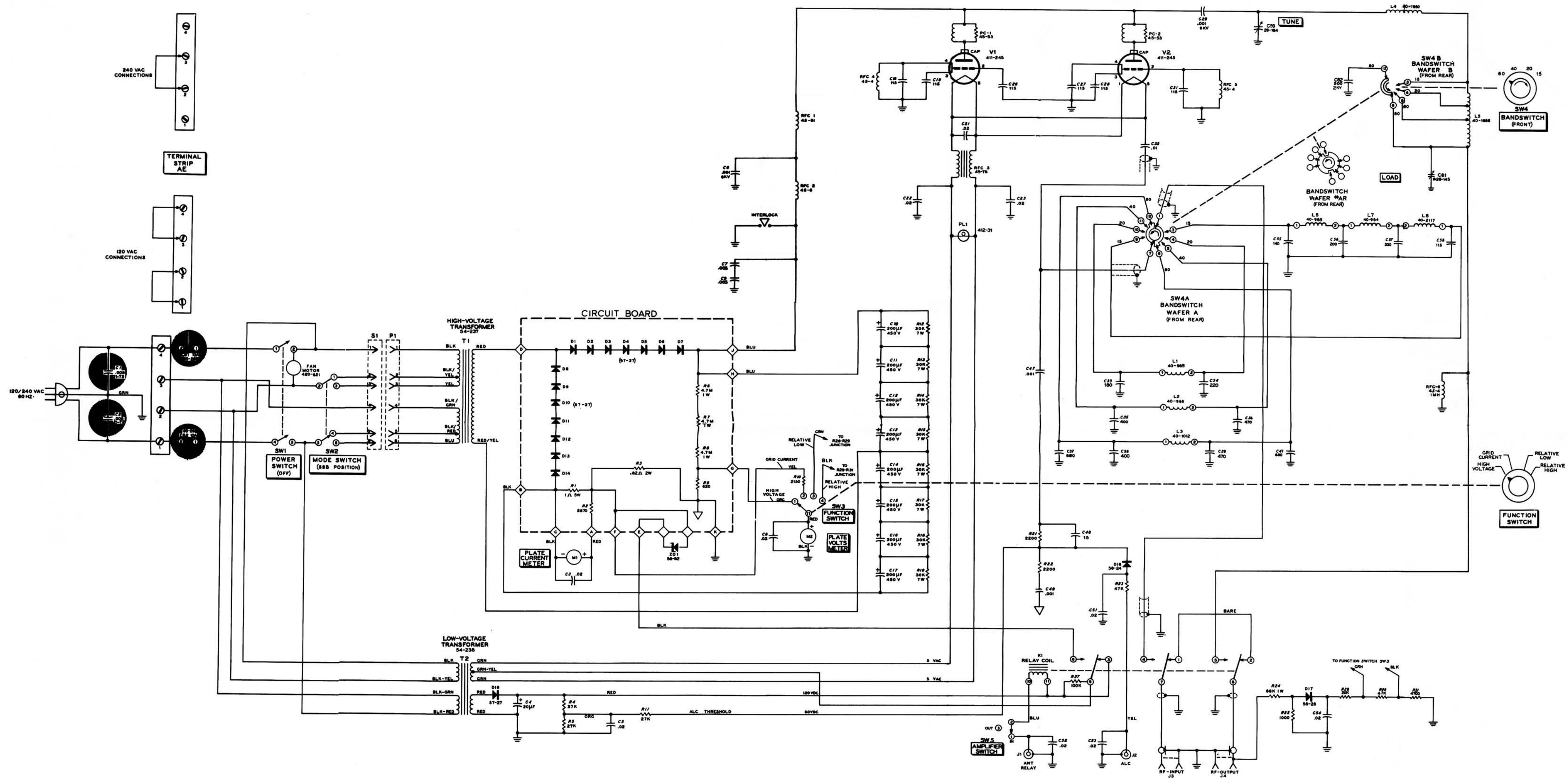

**SCHEMATIC OF THE
HEATHKIT®
2KW LINEAR AMPLIFIER
MODEL HL-2200**

- NOTES:
1. ALL RESISTORS ARE 1/2 WATT UNLESS OTHERWISE INDICATED. VALUES ARE IN OHMS (K=1,000, M=1,000,000).
 2. CAPACITOR VALUES LESS THAN 1 ARE IN μ F. VALUES OF 1 AND ABOVE ARE IN pF UNLESS MARKED OTHERWISE.
 3. THE BANDSWITCH IS IN THE 80 METER POSITION. ARROWS INDICATE THE DIRECTION OF ROTATION FOR THE VIEW SHOWN.
 4. ∇ THIS SYMBOL INDICATES A CONNECTION TO CIRCUIT BOARD GROUND FOIL.
 5. \square THIS SYMBOL INDICATES A CONNECTION TO THE CIRCUIT BOARD.
 6. PARTS IN SHADED AREAS ARE CRITICAL FOR CONTINUED SAFETY. REPLACE THEM ONLY WITH PARTS OF THE SAME RATING OR WITH THE PROPER HEATH PARTS.

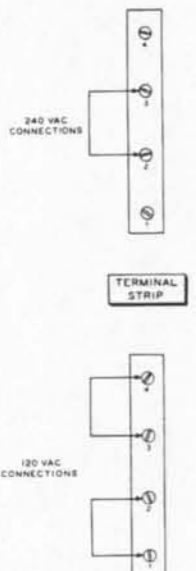

**SCHEMATIC OF THE
HEATHKIT®
2KW LINEAR AMPLIFIER
MODEL SB-220**

- NOTES:
1. ALL RESISTORS ARE 1/2 WATT UNLESS OTHERWISE INDICATED. VALUES ARE IN OHMS (K=1,000, M=1,000,000).
 2. CAPACITOR VALUES LESS THAN 1 ARE IN μ F. VALUES OF 1 AND ABOVE ARE IN μ F UNLESS MARKED OTHERWISE.
 3. THE BANDSWITCH IS IN THE 80 METER POSITION. ARROWS INDICATE THE DIRECTION OF ROTATION FOR THE VIEW SHOWN.
 4. ∇ THIS SYMBOL INDICATES A CONNECTION TO CIRCUIT BOARD GROUND FOIL.
 \blacktriangle THIS SYMBOL INDICATES A CONNECTION TO THE CIRCUIT BOARD.

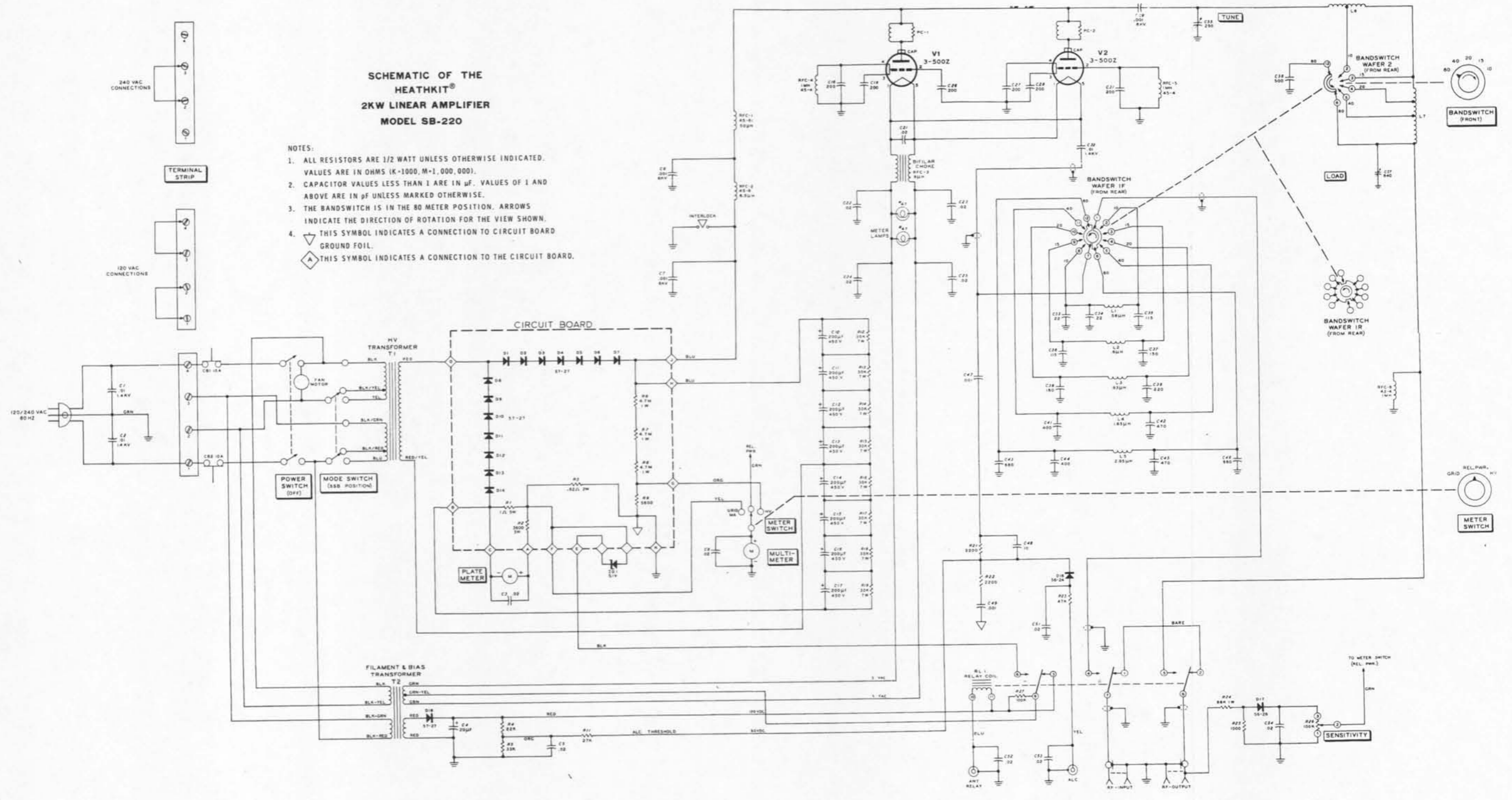

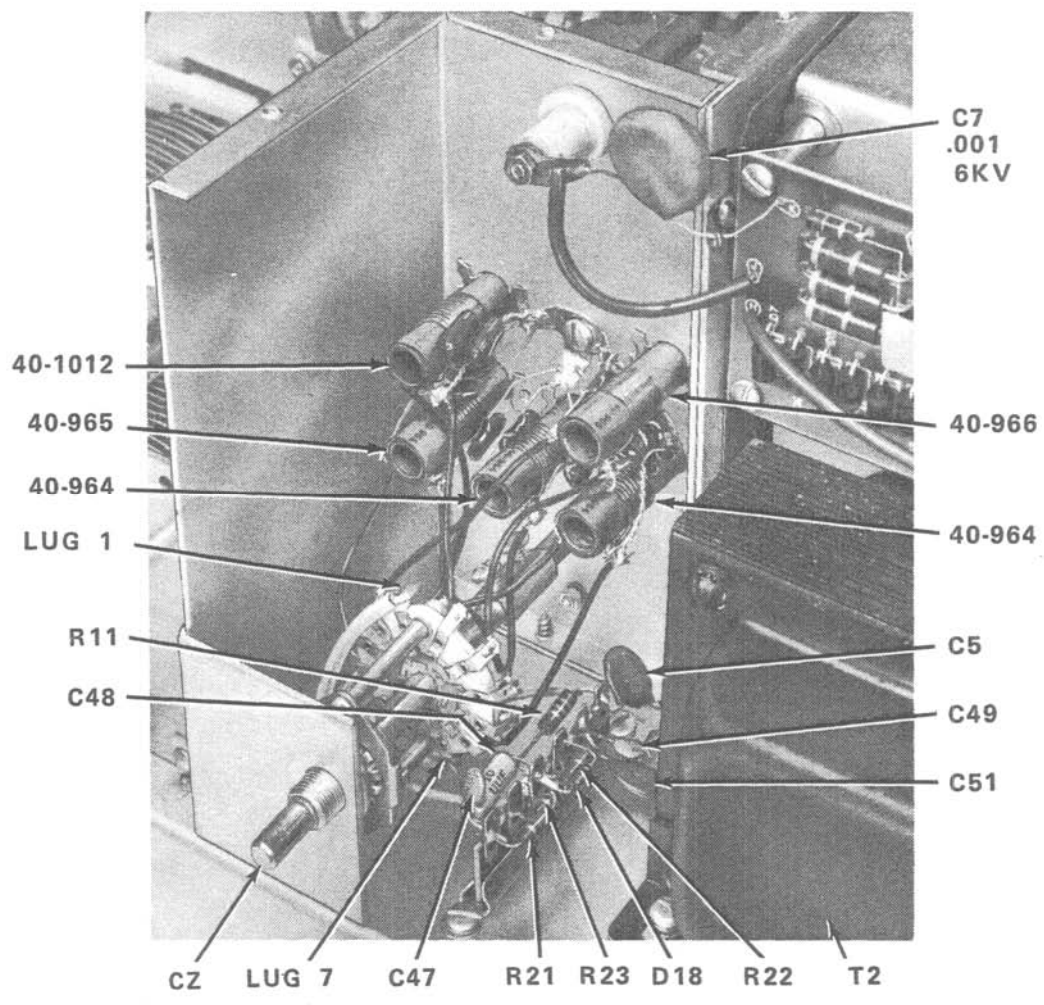

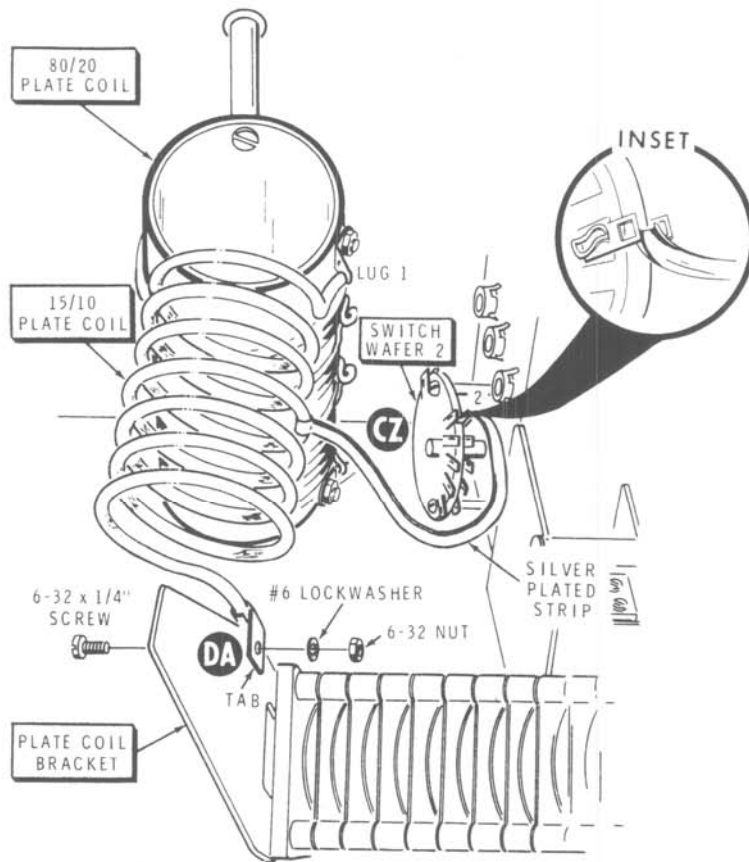

Detail 4-5L

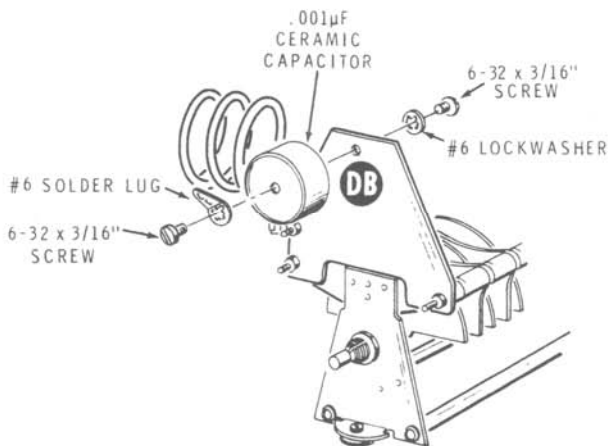

Detail 4-5M

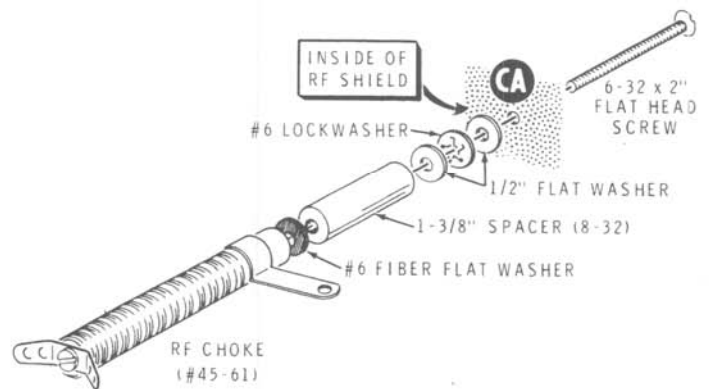

Detail 4-5N

PARTS LIST

This Parts List contains all of the parts used in the assembly of the kit. Some parts are packaged in envelopes with the part number of the contents printed on the outside. Except for the initial parts check, retain these parts in their envelopes until they are called for in the assembly steps.

Check each part against the following list. The key numbers correspond to the numbers on the Parts Pictorial (fold-out from Pages 4 and 7).

To order a replacement part, refer to the "Parts Order Form" furnished with this kit. If a Parts Order Form is not available, refer to "Replacement Parts" inside the rear cover of the Manual. For pricing information, refer to the separate "Heath Parts Price List."

KEY PART		PARTS Per Kit	DESCRIPTION
No.	No.		
RESISTORS			
1/2 Watt			
1	1-9	1	1000 Ω (brown-black-red)
	1-44	2	2200 Ω (red-red-red)
	1-18	1	5600 Ω (green-blue-red)
	1-22	1	22 k Ω (red-red-orange)
	1-23	1	27 k Ω (red-violet-orange)
	1-24	1	33 k Ω (orange-orange-orange)
	1-25	1	47 k Ω (yellow-violet-orange)
	1-26	1	100 k Ω (brown-black-yellow)
Other Resistors			
2	1-8-1	1	68 k Ω 1 watt (blue-gray-orange)
	1-38-1	3	4.7 M Ω 1 watt (yellow-violet-green)
	3-1-2	1	.82 Ω wire-wound 2 watt (gray-red-silver) (same size as 1 watt), 5%
3	3-25-5	1	1 Ω wire-wound, 5 watt, 1%
	3-22-5	1	3600 Ω wire-wound, 5 watt, 1%
4	5-2-7	8	30 k Ω film, 7 watt

KEY PART		PARTS Per Kit	DESCRIPTION
No.	No.		
CAPACITORS			
Molded Mica			
5	20-3	6	200 pF (red-black-brown)
6	20-123	1	500 pF (.0005 μ F)
Mica			
7	20-99	2	22 pF
	20-124	2	115 pF
	20-103	1	150 pF
	20-105	1	180 pF
	20-120	1	220 pF
	20-116	2	400 pF
	20-113	2	470 pF
	20-107	2	680 pF
Disc			
8	21-79	1	.001 μ F 6 kV
9	21-140	2	.001 μ F 500 volt
	21-70	3	.01 μ F 1.4 kV
	21-31	12	.02 μ F 500 volt

KEY PART			DESCRIPTION	KEY PART			DESCRIPTION
No.	No.	Per Kit		No.	No.	Per Kit	
Other Capacitors				INSULATORS-GROMMETS-TERMINAL STRIPS-CONNECTORS			
10	21-28	1	10 pF (10 MMF or 10 $\mu\mu\text{F}$) tubular ceramic	38	71-2	1	Ceramic feedthrough insulator (disassembled in bag)
11	21-165	2	.001 μF (1000 MMFD) 6 kV, ceramic	39	73-4	1	5/16" grommet
12	25-19	1	20 μF (MFD) electrolytic	73-3		4	1/2" grommet
13	25-224	8	200 μF (MFD) electrolytic	73-2		1	3/4" grommet
14	26-145	1	840 pF variable	40	75-123	1	Line cord strain relief
15	26-131	1	250 pF variable	75-124		1	6" x 4-1/2" fish paper insulator
CONTROLS-SWITCHES				41	75-125	8	Capacitor mounting insulator
16	10-12	1	100 k Ω control	42	75-539	1	6-32 x 1-1/4" tapped phenolic spacer
17	61-14	1	DPST rocker switch	43	255-42	3	6-32 x 3/4" tapped phenolic spacer
18	61-15	1	DPDT rocker switch	44	431-14	1	2-lug terminal strip
19	63-47	1	3-position rotary switch	45	431-10	3	3-lug terminal strip
20	63-561	1	5-position rotary switch	46	431-42	1	5-lug terminal strip
21	63-562	1	Rotary switch wafer	47	431-20	1	6-lug terminal strip
22	65-28	2	Circuit breaker	48	431-13	1	4-screw terminal strip
23	69-55	1	TPDT 110 VDC relay	49	432-137	6	Connector tab
COILS-CHOKES-TRANSFORMERS				50	434-42	2	Phono socket
24	40-1666	1	80/20 plate coil	51	434-93	2	5-lug ceramic tube socket
25	40-964	2	10/15-meter input coil	52	436-5	2	Coaxial jack
	40-965	1	20-meter input coil	53	438-9	2	Coaxial plug
	40-966	1	40-meter input coil	54	438-12	1	Coaxial plug insert
	40-1012	1	80-meter input coil	WIRE-CABLE-SLEEVING			
26	40-968	1	15/10 plate coil	89-40		1	Line cord
27	45-53	2	Parasitic choke	134-36		2	Phono cable assembly
28	45-4	3	1 mH RF choke	340-1		1	Small bare wire
29	45-6	1	8.5 μH RF choke	340-4		1	Large bare wire
30	45-78	1	9 μH RF choke	343-2		1	Coaxial cable, RG-58A/U
31	45-61	1	50 μH RF choke	343-8		1	Coaxial cable, RG-8/U
32	54-237	1	High voltage transformer	344-2		1	Small black stranded wire
	54-238	1	Filament and bias transformer	344-7		1	Large black stranded wire
DIODES-TUBES				344-13		1	Blue hookup wire (thick insulation)
33	56-24	1	1N458 silicon diode (yellow-green-gray)	344-50		1	Black hookup wire
34	56-26	1	1N191 germanium diode (brown-white-brown)	344-51		1	Brown hookup wire
35	56-82	1	1N3996A zener diode, 5.1V, 10 watt, w/mounting hardware	344-52		1	Red hookup wire
36	57-27	15	Silicon diode	344-53		1	Orange hookup wire
37	411-245	2	3-500Z tube	344-54		1	Yellow hookup wire
				344-55		1	Green hookup wire
				344-56		1	Blue hookup wire
				345-1		1	Large metal braid
				345-2		1	Small metal braid
				346-4		1	Black sleeving
				346-7		2	Clear sleeving (large)
				346-29		1	Clear sleeving (small)
				55	354-5	6	Cable tie

KEY PART No.	PARTS No.	DESCRIPTION	KEY PART No.	PARTS No.	DESCRIPTION
HARDWARE			Other Hardware (cont'd.)		
#6 Hardware			97	258-115	1 Brass spring 5/8" x 3-1/2'
56	250-138	9 6-32 x 3/16" screw	98	259-10	1 Control solder lug
57	250-56	31 6-32 x 1/4" binder head screw	99	259-24	1 Long solder lug
58	250-416	1 6-32 x 1/4" flat head screw	100	260-12	2 Plate connector
59	250-8	29 #6 x 3/8" sheet metal screw	101	456-16	1 Shaft coupler
60	250-32	18 6-32 x 3/8" flat head screw	METAL PARTS		
61	250-89	15 6-32 x 3/8" binder head screw	102	90-464	1 Cabinet
62	250-218	4 6-32 x 3/8" phillips head screw	103	200-1251	1 Chassis
63	250-206	13 6-32 x 11/16" screw	104	100-1022	1 Capacitor bank bracket
64	250-40	4 6-32 x 1-1/2" screw	105	203-643	1 Front panel
65	250-47	1 6-32 x 2" screw	106	203-644	1 Rear panel
66	252-3	63 6-32 nut	107	203-646	1 Left side panel
67	253-1	17 #6 fiber flat washer	108	203-645	1 Right side panel
68	253-2	2 #6 fiber shoulder washer	109	204-1041	2 Angle bracket
69	253-96	4 #6 flat metal washer	110	204-2102	1 Plate coil bracket
70	254-1	64 #6 lockwasher	111	205-723	1 Top rear plate cover
71	255-77	2 7/16" spacer	112	205-724	1 Perforated top cover
72	255-71	4 6-32 x 3/4" tapped metal spacer	113	205-874	1 Perforated fan cover
73	255-21	3 6-32 x 7/8" tapped spacer	114	206-493	1 RF shield
74	259-1	19 #6 solder lug	115	206-457	1 Coil mounting shield
#8 Hardware			MISCELLANEOUS		
75	250-43	8 8-32 x 1/4" setscrew		85-344-1	1 Printed circuit board
76	250-137	8 8-32 x 3/8" screw	116	255-59	2 Black tapered spacer
77	252-4	8 8-32 nut	117	261-9	4 Rubber foot
78	254-2	8 #8 lockwasher		266-296	1 Fan blade
79	255-66	1 8-32 x 1-3/8" spacer	118	352-13	1 Silicone grease
80	259-2	1 #8 solder lug	119	407-145	1 Plate amperes meter
#10 Hardware				407-146	1 Multi-meter
81	250-331	1 10-32 x 1" screw		420-601	1 Fan motor
82	252-5	2 10-32 nut	120	453-135	1 Phenolic shaft
83	252-163	1 10-32 wing nut	121	462-191	2 Small knob
84	254-3	2 #10 lockwasher	122	462-210	3 Large knob
Other Hardware				390-147	1 Danger high voltage label
85	207-8	2 Cable clamp	123	391-64	1 Nameplate
86	250-213	8 4-40 x 5/16" screw		391-34	1 Blue and white label
87	252-15	8 4-40 nut	124	432-199	1 Wire nut
88	252-7	3 Control nut		490-5	1 Nut starter
89	252-10	2 Speednut		597-260	1 Parts Order Form
90	253-10	3 Control flat washer		597-308	1 Kit Builders Guide
91	253-42	14 1/2" flat washer			1 Manual (See front cover for part number.)
92	253-19	2 3/4" flat washer			
93	254-4	2 Control lockwasher			
94	254-9	16 #5 lockwasher			
95	259-25	1 #10 double lug			
96	259-16	1 #10 solder lug			
					Solder