

SS-221-120 & SS-221-240 SOFT-START v3.0 ASSEMBLY & INSTALLATION INSTRUCTIONS

WARNING: Voltages inside the amplifier CAN & WILL KILL YOU! You MUST know how to work around HIGH VOLTAGE safely. If you do not, get assistance from someone who does. You MUST also be able to read your specific amplifier schematic and understand the design, theory and wiring of your amplifier to properly perform this upgrade.

SS-221 SOFT-START ASSEMBLY

- () **Read, re-read and fully understand these instructions prior to beginning this upgrade.** Make sure to perform the steps in the order they are listed. Also, be sure to label wires as they are disconnected from various points inside the amplifier. This will help when the time comes to re-attach the wires that will be disconnected during installation of the kit.
- () Go through the Bill of Materials (BOM) and compare that list with the parts in the kit to make sure all parts are present. If you are missing any parts, please contact Harbach Electronics, LLC.
- () If the SS-221 is to be installed in an SB-220/221 operating from 120 VAC mains (model SS-221-120), the 10 Ω 10-watt resistors will be included in the kit. If the SS-221 is to be installed in an SB-220/221 operating from 240 VAC mains (model SS-221-240), the 20 Ω 10-watt resistors will be included in the kit.
- () Solder components K1, K2, R25, R26 and R27 to the top (silk screened) side of the printed circuit board (PCB) per parts layout diagram and silk screen on the top of the PCB. All components mount flat to the PCB. Trim the component leads flush on the bottom side of the PCB.

SS-221 SOFT-START INSTALLATION

- () Unplug the amplifier power cord from the AC mains and let any high voltage stored in the electrolytic capacitors bleed down. Verify the HV has bled down as shown on the HV meter. Remove any input, output and control cables that may be connected to the back of the amplifier.
- () **Be sure that all high voltage has been properly bled to ground before removing any covers or putting your hands inside the amplifier. You CAN BE KILLED by the high voltages inside this equipment!**
- () Place the amplifier on a book, front panel up, and remove the bottom screws holding the feet and case in place. Lift the case up and remove it from the amplifier. Place the amplifier upside down on the bench with the front panel facing you. The assembled SS-221 module will be mounted in the open space on the chassis over the capacitor bank in front of the AC mains voltage selector strip AE.

- () Strip about ¼” of insulation from the ends of the two (2) 6” #14 **BLACK** wires, the 4” #20 **RED** wire and the 7” #20 **BLACK** wire. Tin the ends of each of the wires as this will help when soldering the wires to the “Soft Start” module or terminal lugs. Pass one end of each of the 6” #14 **BLACK** wires through the holes (pads) labeled “A” and “B” and solder. Pass one end of the 7” #20 **BLACK** wire through the hole labeled “E” and solder. Pass one end of the 4” #20 **RED** wire through the hole labeled “F” and solder.
- () Cut the 2 cable ties on the power lead wiring that are nearest the back panel.

Refer to the drawing below for the next six (6) steps.

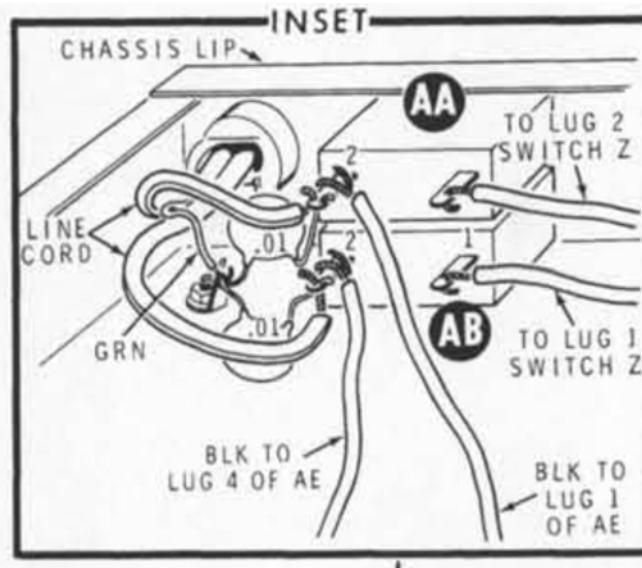

- () Locate the large black wire coming from the right-hand terminal (#1) of the lower circuit breaker (AB). Unsolder this wire and clean the hole in the terminal of the breaker.
- () Cut ½” from the end of this wire and strip about ¼” of insulation from the end of the wire. Tinning the end of the wire will help when soldering the wires to the soft-start module. From the component side of the SS-221 circuit board, pass this wire through hole “C” and solder.
- () Solder the large 6” #14 **BLACK** wire coming from hole “A” of the SS-221 to terminal #1 of the lower circuit breaker (AB), trimming as necessary.
- () In a like manner, remove the large black wire from the right-hand terminal (#1) of the upper circuit breaker (AA). Unsolder this wire and clean the hole in the terminal of the breaker.
- () Cut ½” from the end of this wire and strip about ¼” of insulation from the end of the wire. Tinning the end of the wire will help when soldering the wires to the soft-start module. From the component side of the SS-221 circuit board, pass this wire through hole “D” on the SS-221 circuit board and solder.
- () Solder the large 6” #14 **BLACK** wire coming from hole “B” of the SS-221 to terminal #1 of the upper circuit breaker (AA), trimming as necessary.

Refer to the drawings below for the next seven (7) steps.

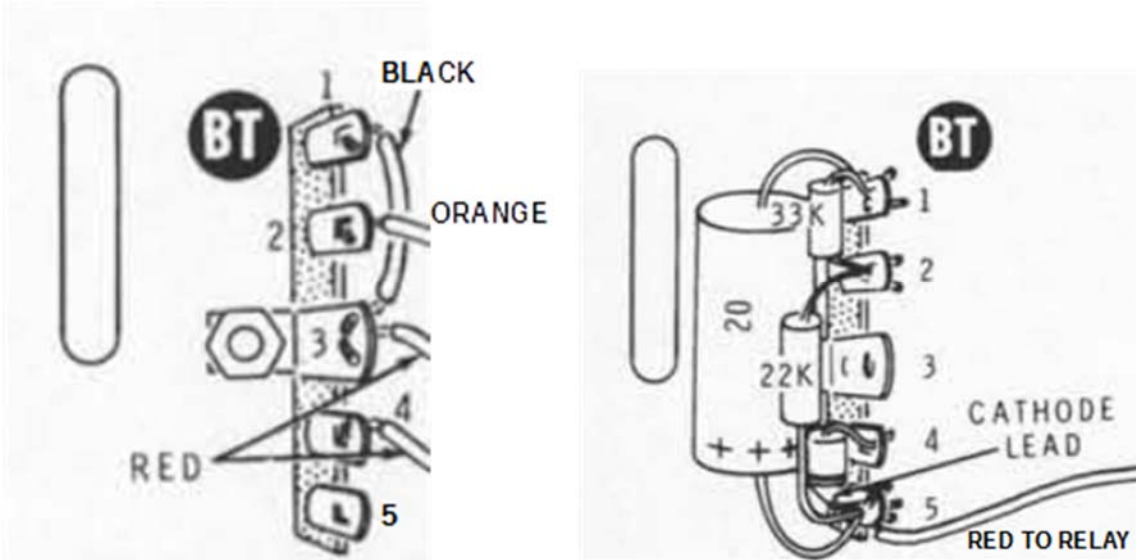

- () Locate the 5-lug terminal strip “**BT**”. It has 2 resistors, a 20µF electrolytic capacitor and a diode connected to it. It is located on the left side of the chassis, slightly forward of middle.
- () Remove the diode between lugs #4 and #5. Remove the red transformer wire connected to the center ground lug #3. Clean out the ground lug #3 and the lug #5 that has the “+” lead of the 20µF electrolytic capacitor soldered to it. Lug #3 should still have a black wire from lug #1 connected to it.
- () Find the small bridge rectifier supplied with the kit. Note that the positive (+) terminal is marked on the top of the bridge. The negative (-) terminal is directly opposite of (across from) the positive terminal and the AC terminals are the remaining 2 leads. With the rectifier on the right side of the terminal strip (wires up), put the (+) through lug #5 of the terminal strip (the one with the “+” lead of the 20µF electrolytic capacitor going to it). Put the small 4” #20 **RED** wire from hole “**F**” of the SS-221 through the same lug #5, trimming as necessary. Solder 5 wires or 6 wires at lug #5 as listed below.
 - The positive (+) lead of the 20µF electrolytic capacitor
 - The small **RED** wire going to the T/R relay
 - One lead of the 22KΩ resistor
 - The small **RED** wire from hole “**F**” on the SS-221 PC board
 - The positive (+) lead of the bridge rectifier
 - The small **RED** wire from the SK-220 (if the SK-220 is installed in the amplifier)
- () Put the (-) lead of the bridge rectifier that is opposite of the (+) lead through the center (ground) lug #3 of the terminal strip. Put the small 7” #20 **BLACK** wire from hole “**E**” of the SS-221 through the same lug #3, trimming as necessary. Solder 3 wires at lug #3 as listed below.
 - The negative (-) lead of the bridge rectifier
 - The small #20 **BLACK** wire from hole “**E**” of the SS-221 PCB
 - The small black jumper wire from lug #1
- () Solder the left lead of the bridge rectifier to terminal lug #4 that has the **RED** wire from the transformer soldered to it. The bridge rectifier lead is marked with a (~) on the top of the bridge.

- () Solder the loose **RED** transformer wire (removed from lug #3 earlier) to the remaining lead of the bridge rectifier. This lead is also marked with a (~) on the top of the bridge.
- () Position the bridge rectifier so that it is clear of any wiring. It will be held in place by its leads.
- () Locate the #8-32 screw just forward and to the left of the line voltage selector terminal strip "**AE**". This holds one corner of the HV transformer to the chassis. Remove the nut and place the #8 solder lug (supplied) over the protruding screw. Replace the nut and hand-tighten.
- () Take two (2) of the supplied 390V ZNR suppressors marked V14391U and put one lead of each through the new solder lug. The other end of the ZNR suppressors connect to terminals 1 and 4 of the voltage selector terminal strip "**AE**" (NOT to the screws holding the terminal strip down).
- () Position the ZNR suppressors and the ground lug so that the ZNR leads are in the clear. Solder the two (2) leads to the ground lug and trim off any excess. Now fully tighten the #8-32 screw and nut holding the ground lug and transformer.
- () The third 390V ZNR suppressor marked V14391U is connected between the terminals 1 and 4 of the voltage selector terminal strip "**AE**" (the same strip where the other ZNR suppressors are connected). Place the leads from the ZNR suppressors under the terminal screws and tighten.
- () Dress the power leads back into the wire bundle and tie using lacing, cord, string or tie-wraps.

Refer to the drawing below for the next two (2) steps.

- () Locate the T/R relay and identify the wires connected to the relay coil. There should be a red wire on the lug #11 nearest the front panel. Solder the lead from the banded end (cathode) of one of the supplied 1N4005 diodes to the relay coil lug #11. Solder the lead from the unbanded end (anode) of the other supplied 1N4005 diode to the opposite relay coil lug #10. Both free diode leads should be extending to the right, toward the output coax cable and wrap around the body of the relay.
- () Bend the two (2) free diode leads so that they touch, but are clear of any other wiring. Trim and solder these leads together. See the drawing below.

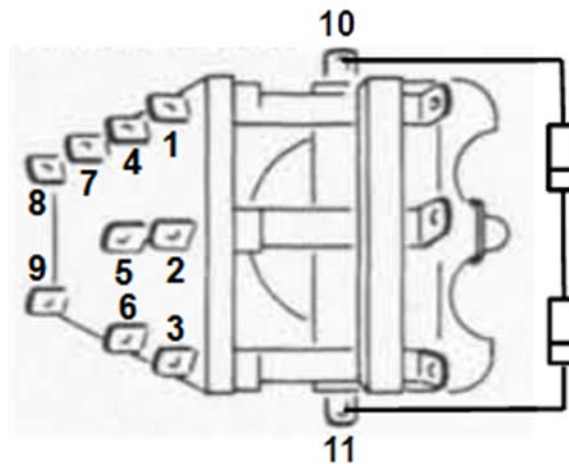

- () Examine the tops of the relay cases on the soft-start module. If there are vent holes in the tops, be careful not to cover these holes if you use RTV or silicone to mount the unit.

- () Mount the SS-221 module in the clear space in front of the AC mains voltage selector strip AE using the holes in the corners of the PC board and nylon standoffs and hardware or by using a small dab of RTV or other silicone adhesive on the inner top of each relay on the circuit board and sticking it to the chassis. You may also mount a piece of rubber or other insulating material on the trace side of the SS-221 if desired.

This completes the installation of the SS-221 soft-start module. Before putting the case back onto the chassis, it would be wise to check the operation. **NOTE: MAKE SURE THE BRASS SPRING SAFETY INTERLOCK IS NOT GROUNDED BEFORE PLUGGING INTO AN AC OUTLET. FAILURE TO DO THIS WILL SHORT CIRCUIT THE HIGH VOLTAGE SUPPLY TO GROUND AND DAMAGE WILL RESULT IF POWER IS APPLIED!** Turn the amplifier over and plug it in and place the multi-meter switch to the "HV" position. With the power selector switch in the "CW" position, turn the amplifier on. Observe the plate voltage. After about one half second, it should read its normal reading. You will hardly notice any difference in the operation of your SB-220/SB-221, but you will know it is very well protected from voltage transients and high inrush currents.

SS-221 SOFT-START PCB PARTS LAYOUT (PCB-101)

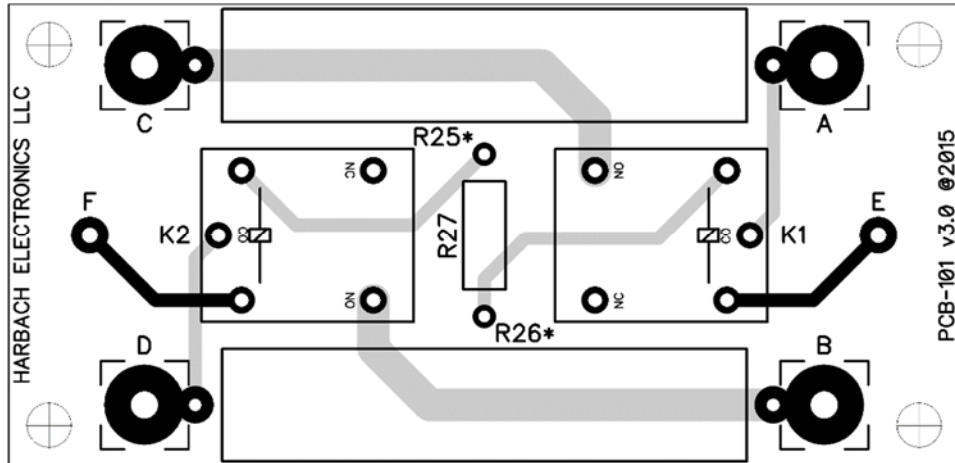

SS-221 BILL OF MATERIALS (BOM)

Verification	Part Number	Quantity	Description	PCB Designation
[]	PCB-101	1	SS-221 Soft-Start PCB v3.0	N/A
[]	DIO-101	2	1A 600 PIV Diode (1N4005)	N/A
[]	DIO-103	1	1.5A 600V Bridge Rectifier	N/A
[]	LUG-102	1	#8-32 2-Hole Solder Lug	N/A
[]	REL-104	2	SPDT 48VDC Relay	K1, K2
[]	RES-102*	2	20Ω 10W Resistor	R25, R26
[]	RES-104*	2	10Ω 10W Resistor	R25, R26
[]	RES-103	1	3kΩ 2W Resistor	R27
[]	WIR-101	2 x 7"	#14 Stranded Black Wire	N/A
[]	WIR-106	7"	#20 Stranded Black Wire	N/A
[]	WIR-111	5"	#20 Stranded Red Wire	N/A
[]	ZNR-102	3	390V Transient/Surge Suppressor	N/A

* RES-102 or RES-104 will be supplied with the kit depending on whether the kit is for 120VAC mains operation (SS-221-120) or 240VAC mains operation (SS-221-240).

HARBACH ELECTRONICS, LLC

Jeff Weinberg – W8CQ

468 County Road 620

Polk, OH 44866-9711

(419) 945-2359

<http://www.harbatchelectronics.com>

info@harbatchelectronics.com