

## **C300C Series Low Band Amplifiers Operating and Maintenance Manual**

**SOLID-STATE RADIO FREQUENCY  
POWER AMPLIFIER**

***HENRY RADIO, INC.***

2050 S. Bundy Drive Los Angeles, CA 90025 USA

310-820-1234 310-826-7790 fax e-mail:

henryradio@earthlink.net henryradio.com



**LIMITED WARRANTY:** Henry Radio warrants each new product to be free from defective material and workmanship. Henry Radio agrees to remedy any such defect or to furnish a new part in exchange for any part of any unit which under normal installation, use, and service discloses such defect. The equipment or part must be delivered by the original owner to us intact for our examination, with all transportation charges prepaid to our factory, within 1 year from the date of sale to the original purchaser. Provided that our evaluation discloses, in our judgement, such a defect, Henry Radio will repair at no charge, or replace at their discretion, such defective part or equipment.

**EXCLUSIONS:** Henry Radio does not warrant any vacuum tube used in their equipment. These are warranted by the tube manufacturer. Warranty claims must include proof of the date of purchase. The warranty does not extend to damage or failure caused by transportation damage, misuse, neglect, accident, incorrect installation, acts of nature, or to equipment modified or repaired without our prior approval.

This warranty does not include incidental or consequential damages and the Henry Radio warranty disclaims any liability for any such damage. All implied warranties, if any, are limited in duration to the above stated 1 year.

Henry Radio reserves the right to make any improvements to its products which it may deem desirable without obligation to install such improvements in its previously sold products.

## C300C Series Low Band VHF Amplifiers

### SPECIFICATIONS

|                         |  |
|-------------------------|--|
| RF Output Power:        | 300 watts maximum.   |
| RF Input Power:         | 2-4 watts (C300C02R), 8-10 watts (C300C10R),<br>30-35 watts (C300C30R) maximum.                                |
| Frequency Range:        | 30 to 60 MHz (5 MHz tuned bandwidth).  |
| Input/Output Impedance: | 50 ohms nominal.   |
| Harmonic Suppression:   | 70 dB nominal.   |
| Mode:                   | Class C (for FM operation).  |
| RF Connectors:          | N(f) or UHF(f) chassis jacks.  |
| Duty Cycle:             | Continuous at rated output.  |
| Cooling:                | Built-in DC fans with thermostat control.  |
| Power Requirements:     | 13.8 VDC, negative ground, 45 amps maximum.  |
| Dimensions:             | 19" wide x 6.25" high x 6" deep.   |
| Shipping Weight:        | 15 pounds.   |
| Options:                | Bypass (dropout) Relay.<br>Transmit/Receive Relay system   |
| Warranty:               | Base Package - with integrated AC power supply<br>AC power supply (110 or 220 VAC).<br>1 year parts and labor. |

Made in the USA



## INSTALLATION NOTES

### INTRODUCTION

Remove the amplifier from its packing material and examine it carefully for damage in shipping. If the amplifier was damaged in shipment, save the box and packing material and notify the transportation company immediately.

The amplifier was tested and tuned at our factory at the operating frequency specified when the order was placed. A description of the frequency and test results is included on an enclosed test sheet. These tests were made into a 50 ohm dummy load.

The installer is responsible to provide the following items:

- A 50 ohm antenna tuned to the operating frequency
- An operating location with proper ventilation to prevent overheating
- Output coax to connect the amplifier and antenna that can handle 300+ watts at up to 50 MHz (RG213, 9913, or hardline) without overheating
- An operating location protected from environmental hazards such as water, heat, pests, or dust
- A stable drive signal at the input jack of the amplifier adjusted to a proper power level.

### INSTALLATION

Connect the amplifier to a 13.8 VDC power supply capable of supplying at least 90 amps of power in continuous service. Or connect it to an AC source if you purchase the /B base package. You must use a wire gauge large enough to prevent voltage drop at high current levels.

Connect your transmitter/repeater to the RF input connector on the amplifier using 50 ohm coax cable.

Connect the amplifier to your antenna or a

50 ohm dummy load on your test bench.

Install a through-line wattmeter in the output cable (either a Bird 43 or equal). Turn on the power supply and the transmitter.

Slowly increase the power from your transmitter until the output power of the amplifier reaches the desired level - as shown on the wattmeter.

If you do not have a wattmeter, an alternate method is to use the performance figures shown on the supplied test sheet to approximate the output.

At the operating power level, reverse the wattmeter element and confirm that the reflected power is near zero. If the reflected power is greater than 10% of the output power, your antenna is not properly tuned and you may damage the amplifier!

You can increase reliability and save money by installing proper lightning protection on your antenna system.

### SERVICE AND REPAIR

Should it be necessary to return the amplifier for warranty or non-warranty repair, pack it very carefully to prevent shipping damage.

Be certain to include a written description of the problem, your operating frequency, and any special instructions.

It is wise to call first to make sure it is necessary to return the equipment.

# INSTALLATION DRAWING

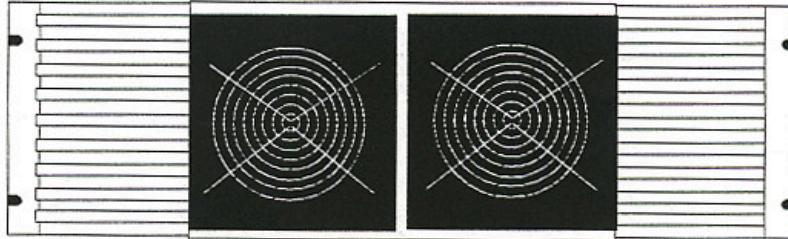

## GOOD RELIABILITY REQUIRES:

Stable RF drive at the proper designated wattage.  
A proper power supply, regulated, 13.8 VDC, 50 amps plus.  
Minimum SWR at the output connector.

Professional lightning protection on the antenna.  
Professional lightning protection on the AC mains.  
Proper environmental protection from dust, moisture, and heat.  
Proper coax on the antenna line.

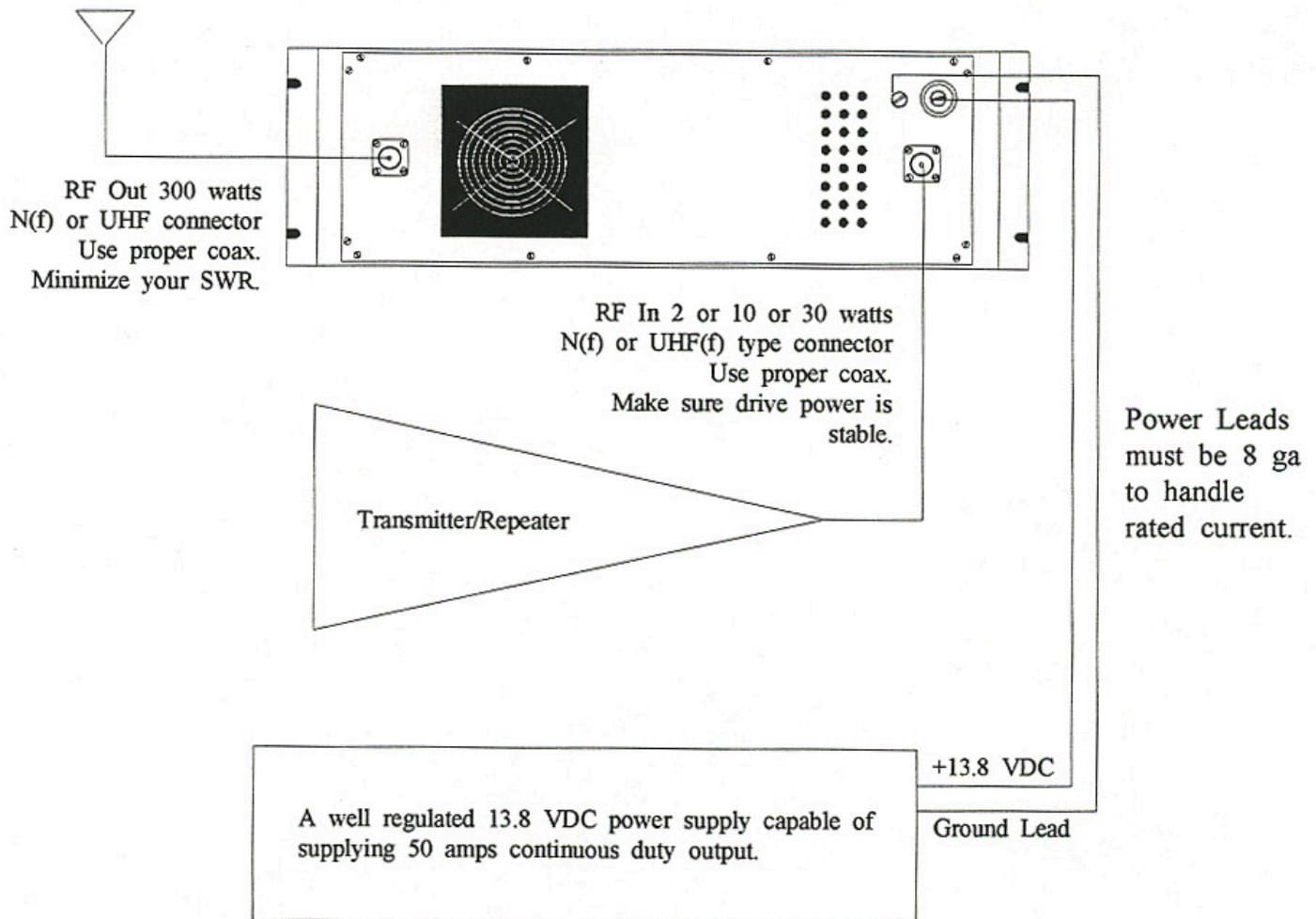



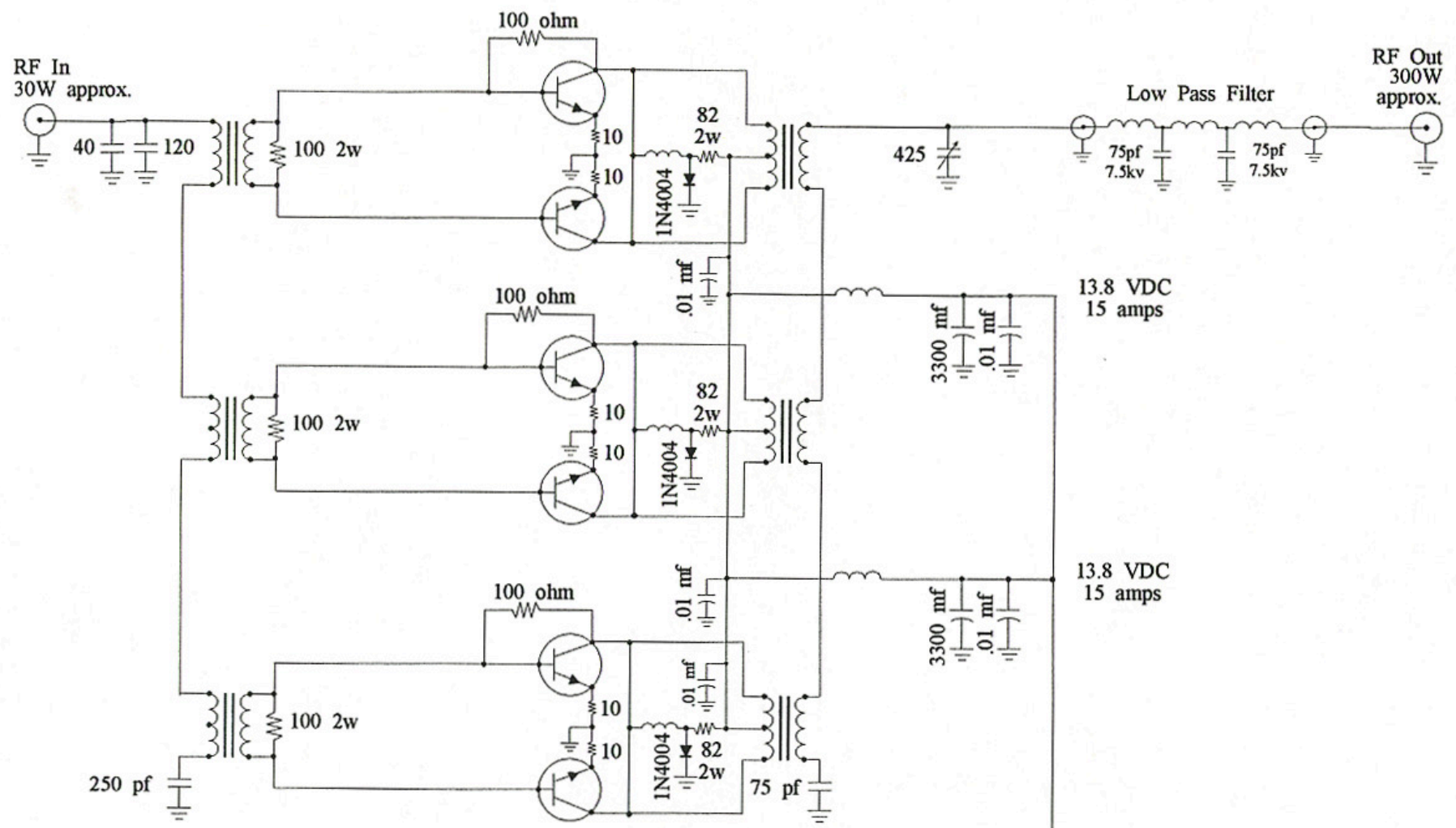

MRF247 x 6

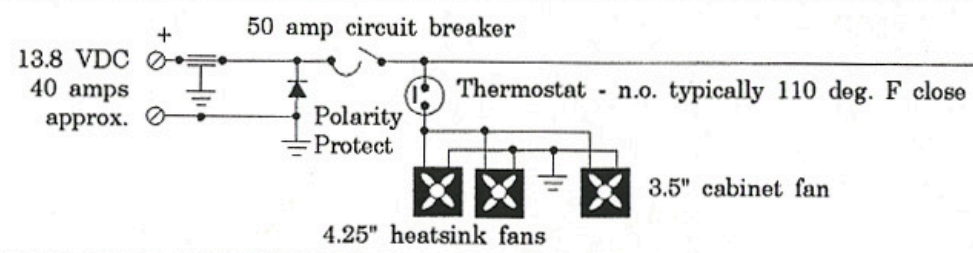

Henry C300C30  
300 Watt Assembly  
30-50 MHz

