



ORDER NO.
481

INSTALLATION & OPERATION INSTRUCTIONS

MOBILE STATION LINEAR AMPLIFIER 12 VDC

HY-GAIN ELECTRONICS CORPORATION
Rural Route 3 Lincoln, Nebraska 68505

GENERAL DESCRIPTION:

This linear amplifier is a precision built, compact, high output amplifier of advanced design. It utilizes two tubes, four transistors and four diodes in a grounded grid, tuned plate circuit for amplification of AM, FM, CW and SSB signals in the 25 to 54 MHz range.

The Linear Amplifier will operate over the frequency range 25-54 MHz. However, it is F.C.C. Type Accepted under Parts 89, 91, and 93 over the frequency range 25-40 MHz.

Operation of this equipment requires a FCC license. Failure to comply is punishable by penalties set forth in the Rules and Regulations of the FCC. A copy of these Rules is available from the U.S. Government Printing Office and should be in the possession of the operator.

The 481 Linear Amplifier complies with FCC regulation when shipped from the factory, and must be used with a transceiver which is FCC Type Accepted under Parts 89, 91, and 93 for the system to be valid.

A special feature of this model is the automatic antenna change over relay which operates without special external connections making it perfect for operation with low power transceivers not having external amplifier control circuits.

Variable plate tune and load capacitors offer impedance matching for maximum output to varying antenna loads in the 40 to 70 ohm range.

The front panel indicator lights provide reliable visual indications of proper amplifier operation without complicated metering circuits.

The amplifier has been designed and constructed to suppress spurious radiation that may cause television interference. The TVI problem was given full consideration in design and layout of the chassis.

There are, however, some types of TVI that cannot be prevented within the amplifier. This is particularly true in weak signal areas. In such cases, a good commercial low pass filter is recommended.

MECHANICAL SPECIFICATIONS:

Height 4 1/8"
Width 7 1/8"
Depth 10 3/8"
Net Weight 5 Pounds
Shipping Weight 8 Pounds
Construction Light weight aluminum chassis
. with rugged steel case.

ELECTRICAL SPECIFICATIONS:

Power Requirement + 12 - 14 VDC
15 Amp
Frequency Range 25-54 MHz*
Types of Emission AM, FM, CW, SSB, DSB
Power Output (Slightly Less at 50 MHz) 220 Watts
PEP, SSB or DSB 80 Watts CW (With 3.5 Watts Drive)
Drive Requirement to Trigger Antenna Relay 1 Watt
Max Drive (unmodulated carrier and FM). 15 Watts
(amplitude modulated carrier). 3.5 watts
(amplitude modulated peak). 14 watts PEP
Harmonic Supression suppressed more than 60db
Input Impedance (unbalanced) 50 Ohms
nominal, less than 2:1 VSWR 25-54 MHz*
Output Impedance (unbalanced) 50 Ohms
nominal, Adjustable 40-70 ohms, nonreactive
Antenna Switching Automatic provided
by RF sensing network
Tube and Diode Complement . . 2 Tubes, 4 Transistors, 4 Diodes
Cable Connector Data Input and Output
require MIL PL-259

*F.C.C. Type Accepted for frequency range 25-40MHZ only

UNPACKING:

Carefully remove the Linear Amplifier from the packing carton. Examine it closely for signs of shipping damage. Remove the four screws holding the top cabinet and remove all hold down tape and packing materials. Check to insure tubes are seated in the sockets. Install the plate caps on the tubes. Inspect for any signs of internal damages.

ASSEMBLY AND INSTALLATION:

NOTE

This unit is made to operate on negative ground systems only.

The location is not critical but consideration must be given to adequate ventilation.

IMPORTANT:

ALLOW AT LEAST FOUR INCHES OF CLEARANCE ON ALL SIDES OF THE CABINET FOR GOOD AIR CIRCULATION.

The primary power connection on the unit is the +12 VDC terminal on the rear panel.

A fuse holder is provided on hook-up cable with a 20 amp fuse. Do not use a larger capacity fuse or the amplifier transformer and power supply will not be protected.

The unit will not operate without grounding. It is recommended that a No. 10 or heavier wire be run from the ground terminal on the Afterburner to the ground terminal of the battery.

ANTENNA:

The Linear Amplifier will work with the common antenna systems designed for the 25-54MHz* range provided the antenna has a resistive input impedance between 40 and 70 ohms. The SWR should be kept to a minimum 2:1 or less.

The output connector provided is an SO-239. For connection of your antenna you will need a PL-259 plug.

FRONT PANEL CONTROLS AND FUNCTIONS:

ON-OFF Switch	Controls 12 VDC power to amplifier
Standby-Operate Switch	Activates the automatic antenna relay circuit
AM-FM & SSB-CW Switch	Adjusts time constant of automatic antenna relay
Green Indicator Light	Visual indication of applied 12 VDC power
Red Indicator Light	Visual Indicator of RF energy output
Tune Control	Adjusts resonant frequency of output circuit
Load Control	Adjusts coupling of output circuit to antenna

INSTALLATION:

The amplifier can be mounted either under the dash (using the bracket provided) or in the trunk as desired.

When the unit is dash mounted, a fused primary connection to the battery or fuse block must be provided.

If trunk mounted, a remote switch must be used, and can be purchased through your local dealer. Mount the remote switch on the dash where it is convenient. Remote switch mounting must be grounded to the vehicle chassis or the indicator light will be inoperative.

IMPORTANT

Remember the front panel and remote switches are series connected. The amplifier will not operate if either switch is in the OFF position.

NOTE

Before beginning installation, it is recommended the positive lead of the battery be disconnected to prevent accidental grounds and electrical system damage.

Connect the fused lead to the positive terminal of the battery or fuse block. The other lead should be run under the seats and carpets in a protected location to the amplifier primary power connection. A length of RG58/U should be installed between the transceiver and amplifier. Connect a nominal 50 ohm antenna to the amplifier.

Connect the ground stud on the amplifier to the vehicle chassis.

Before applying power, make one final check on all wiring and connections.

OPERATION:

WARNING

WHEN THE AMPLIFIER IS USED IN THE BUSINESS BAND, AD-

JUSTMENTS MUST BE MADE ONLY BY A FCC LICENSED TECHNICIAN.

The 481 Linear Amplifier is factory adjusted for the range 25-32 MHz. Operation over the range 32-40 MHz require change in the number of turns in LI (RF Tank Coil). A shorting tap is placed on the end of the coil, from the left-hand side as viewed from the front panel (see fig. 2) to the first turn, counting from the left side.

This Amplifier must be used with a transmitter or transceiver capable of at least one watt output.

Remove Controls cover for tuning and loading.

Install knobs supplied in separate parts pack. Fully mesh both the Tune and Load Capacitors, then install the small knob on the Tune and the big knob on the Load capacitor shaft, insuring that the marking on the knobs are horizontal and pointing to the left when viewed from the front.

WARNING

Before applying any RF power to the Linear, pretune the tune control to the desired frequency at which you wish to operate. See illustration.

For example, if your desired operating frequency is 31 MHz then set the tune knob at midpoint between 29 and 33 as shown.

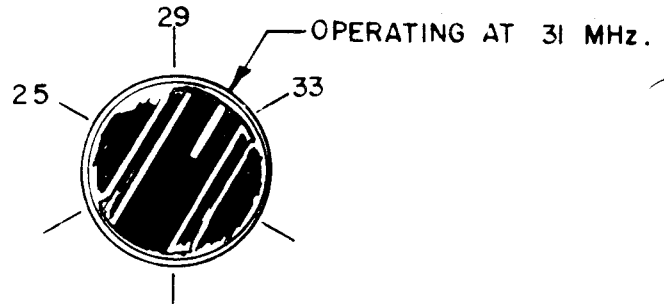

FIGURE 1 TUNE CONTROL KNOB

NOTE

For operation on the 50 to 54 MHz band set tune control to the 29 MHz position as shown above. Then refer to 50 to 54 MHz Operation.

TUNING FOR AM USE:

First place the function switch in the AM-FM position. Set the tune control in accordance with the warning on this page of the manual. The load control should be positioned so that the capacitor is fully meshed, (dot on knob will then point to the word "load" on the front panel).

Now push the ON-OFF Switch to ON, the green visual indicator will light.

After warm-up, push the Stby-Oper to OPER. This will energize the automatic antenna relay control circuitry.

Apply drive power by keying the exciter (transceiver) microphone and quickly adjust the tune control for maximum brilliance of the red visual output indicator. Remove drive power after adjustment.

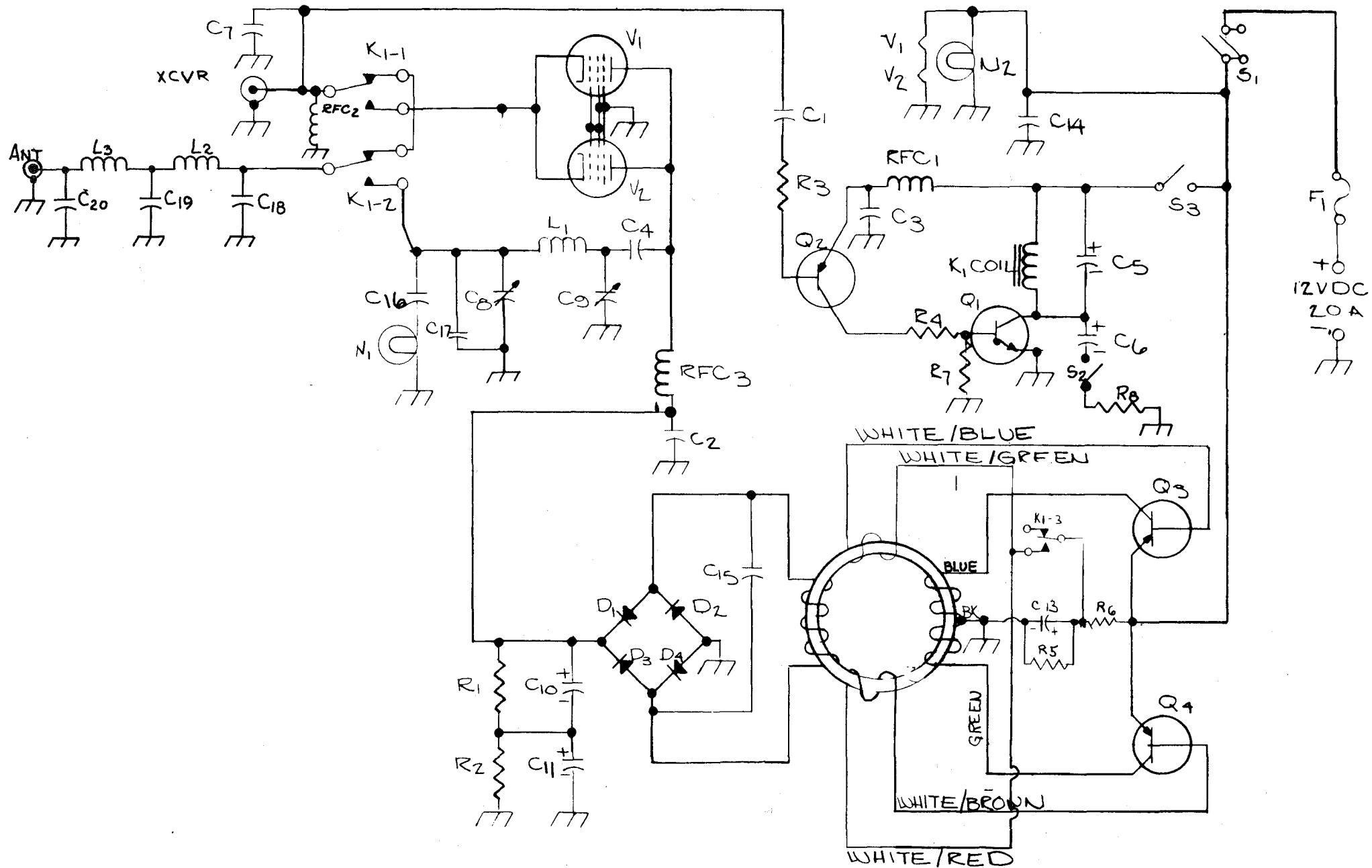

NOTE

Do not apply drive power for more than five seconds without adjusting the tune control or damage to the tubes can result.

Reapply drive power and advance (clockwise) the load control, note the increase in brilliance of the red output indicator. Adjust the load control for maximum brilliance of the output indicator. Now, go back to the tune control and reset for maximum output. Remove drive power.

NOTE

Readjustment of the tuning and loading controls several times will produce maximum output.

To provide for the extra power contained in the AM signal modulation it is necessary to "over-couple" the output circuit. This is necessary to insure an undistorted output, with a minimum of adjacent channel "bleeding". (Spatter).

Reapply drive power and advance the load control until the red visual output indicator dims perceptibly, (about 15 per cent more rotation). Readjust the tune control for maximum output. The output circuit is now "over-coupled".

If a relative power output indicator is available (SWR bridge on forward, etc.) the output signal can be quickly checked to insure upward modulation. If the meter does not "flick" upward on voice peaks, the load control is improperly set, (or the exciter is not capable of 100 per cent modulation or may have "downward modulation").

Always the last adjustment should be the tune control.

Your amplifier is now tuned and ready for operation.

Automatic antenna change over and amplifier operation is provided for by a special transistorized input sensing circuit. Should you desire to hold the amplifier in a "ready" condition, but not use it until needed simply place the Stby Oper Switch in the Stby position. The sensing circuit will be disabled and the antenna connected to the exciter (transceiver) at all times.

TUNING FOR FM:

The amplifier is tuned for FM service in a manner identical to AM except the load and tune controls are set for maximum output. No change in brilliance of the output indicator will be noted with modulation.

TUNING FOR SSB & DSB:

Place the function switch in the SSB position. This will connect a delay circuit to the automatic relay control and extend the "drop-out" approximately one second. This will prevent relay "chattering" and erratic operation.

If the exciter (transceiver) is capable of carrier output equal to the peak power of the voice SSB or DSB signal, simply adjust the tune and load controls for maximum brilliance of the output indicator while applying carrier.

If the exciter (transceiver) cannot supply a carrier equal to the peak power of the voice SSB or DSB signal then the tune and load controls must be set for maximum output while modulating. In this case, a modulation envelope indicator (monitor scope) is the most reliable method for adjustment of the amplifier.

TUNING FOR CW:

(continuous wave telegraphy)

Place the function switch in the SSB position, apply drive power, and adjust the tune and load controls for maximum output.

The delay circuit for SSB prevents "drop-out" of the automatic antennarelay between characters.

Remove knobs and replace controls cover before putting the Amplifier into business radio service.

50-54 MHz OPERATION:

For operation on the six meter amateur band it is necessary to short out four turns of coil L1 and remove capacitors C17 from the circuit. On the Pi-network output coil, L1 short out the three turns of the left hand side (as viewed from the front). See illustration. The 100pf silver mica capacitor C17 must be removed from the Pi-network load capacitor, C8. The size of the output indicator capacitor C16 should be reduced to 5pf.

The low pass filter on the output must be shorted out. This can be done by soldering a wire from the input to the output and removing the three silver mica capacitors (180pF and 240pF) from the small circuit board connected to the output socket.

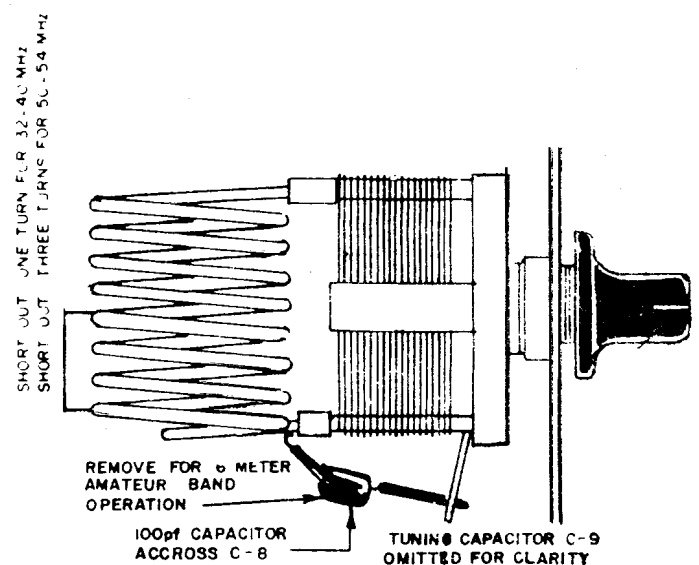

FIGURE 2

CIRCUIT ANALYSIS:

A portion of the incoming signal is coupled to the base of Q2, sensing transistor. This causes Q2 to conduct and change the bias on Q1, relay transistor, Q1 conducts heavily and closes relay K1.

Relay K1 connects the input signal to the cathodes of V1 and V2, applies plate voltage to V1 and V2, and connects the output circuit to the antenna.

C9 is the Pi-net tune capacitor and sets the operating frequency of the amplifier.

C8 is the Pi-net load capacitor and controls the coupling to the antenna.

For SSB operation, C6 is added to the relay transistor circuit to extend the "drop out" time.

WARRANTY POLICY

The manufacturer guarantees to remedy for a period of 90 days from the date of purchase any defect in material or workmanship existing in this model at no cost to the owner, exclusive of shipping charges, provided:

1. The defect is not the result of misuse, neglect, accident, incorrect wiring not our own, improper installation or use contrary to instructions.

2. The unit serial number has been registered by the original purchaser.
3. The unit or part that appears defective is delivered prepaid to the manufacturer or authorized service center that we may designate.
4. Examination discloses, in our judgement, a defective part or workmanship.

This warranty does not extend to any units which have been repaired or altered outside of our factory nor to cases where the serial number has been removed, defaced or changed.

All labor, tubes, semi-conductors and other parts are included in this warranty. Any transportation costs, or similar charges, that may be incurred are not included. The manufacturer's sole liability is the repair at no charge of any defect for the period stated.

This written warranty is in lieu of all warranties expressed or implied and no representative or person is authorized to assume for us any other liability in connection with the sale of our products.

The manufacturer reserves the right to make any changes deemed necessary or desirable to improve the product without incurring obligation to make (or furnish parts for) like changes in units previously manufactured or sold.

All Warranties are void one year after the last model has been manufactured.

