

**hy-gain**

**ORDER NO.  
482**

# INSTALLATION & OPERATION INSTRUCTIONS

*file copy*

**BASE STATION BI-LINEAR AMPLIFIER 115 VAC**

**HY-GAIN ELECTRONICS CORPORATION**  
Rural Route 3 Lincoln, Nebraska 68505

## GENERAL DESCRIPTION:

The Bi-Linear Amplifier is a precision built, compact amplifier of advanced design. It utilizes an integrated circuit, two tubes, two transistors and three diodes and a grounded grid, tuned plate circuit for amplification of AM, FM, CW, and SSB signals

The Bi-Linear Amplifier will operate over the frequency range 25-54 MHz. However, it is F.C.C. Type Accepted under Parts 89, 91, and 93 over the frequency range 25-40 MHz.

Operation of this equipment requires a FCC license. Failure to comply is punishable by penalties set forth in the Rules and Regulations of the FCC. A copy of these Rules is available from the U.S. Government Printing Office and should be in the possession of the operator.

The 482 Bi-Linear Amplifier complies with FCC Regulation when shipped from the factory, and must be used with a transceiver which is FCC Type Accepted under Parts 89, 91, and 93 for the system to be valid.

A special feature of the Amplifier is the automatic antenna change over relay which operates without special external connections making it perfect for operation with low power transceivers not having external amplifier control circuits.

Another feature is that this unit amplifies the received signal, utilizing an integrated circuit amplifier.

Variable plate tune and load capacitors offer impedance matching for maximum output to varying antenna loads in the 40-70 ohm range.

The Bi-Linear Amplifier has been designed and constructed to suppress radiation that may cause television interference. TVI problem has been given full consideration in design and layout of the chassis.

There are, however, some types of TVI that cannot be prevented within the amplifier. This is particularly true in weak signal areas. In such cases, a good commercial low pass filter is recommended.

## MECHANICAL SPECIFICATIONS:

Height	4 1/8"
Width	7 1/8"
Depth	10 3/8"
Net Weight	11 Lbs.
Shipping Weight	12 Lbs.
Construction	Lightweight aluminum chassis with rugged steel case

## ELECTRICAL SPECIFICATIONS:

Power Requirement	115 V AC 3 Amp
Frequency Range	25-54 MHz*
Types of Emmission	AM, FM, CW, SSB, DSB
Power Output (Slightly less at 50 MHz)	220 Watts PEP, SSB, or DSB 80 Watts CW (with 3.5 watts drive)
Amplification of Received Signal	20 db
Drive Requirement to Trigger Antenna Relay	1 Watt
Max Drive (unmodulated carrier and FM)	15 Watts (amplitude modulated carrier). . . . . 3.5 watts (amplitude modulated peak). . . . . 14 watts PEP
Harmonic Supression	suppressed more than 60db
Input Impedance (unbalanced)	.50 Ohms nominal, less than 2:1 VSWR 25-54 MHz*
Output Impedance(unbalanced)	.50 Ohms nominal, Adjustable 40-70 ohms, nonreactive
Antenna Switching	Automatic provided by RF sensing network
Tube and Diode Complement	2 Tubes 2 Transistors, 3 Diodes 1 Integrated Circuit
Cable Connector Data	Input and Output require MIL PL-259

\*F.C.C. Type Accepted for frequency range 25-40 MHz only

## ASSEMBLY AND INSTALLATION:

( ) Carefully remove the amplifier from the packing carton. Examine it closely for signs of shipping damage. Check to insure tubes are seated in the sockets. Check the plate caps on the tubes. Inspect for any signs of internal damage.

### NOTE

*Do not attempt to operate your amplifier until you have read the manual and properly installed the unit.*

- ( ) The location is not critical but consideration must be given to adequate ventilation.
- ( ) **IMPORTANT:** Allow at least 4" of clearance on all sides of the cabinet for good air circulation.
- ( ) The primary power connection on the amplifier is a standard 115V AC line plug.
- ( ) The fuse holder is provided on the rear panel with a 3 amp, 3 AG fuse. Do not use a larger capacity fuse or amplifier, transformer, and power supply will not be protected.
- ( ) The unit should be operated with a good ground. Water pipes and other house fixtures are not recommended.
- ( ) The Bi-Linear Amplifier will work with the common antenna systems designed for the 25-54 MHz\* range provided the antenna has a resistive input impedance between 40-70 ohms. The SWR should be kept to a minimum of 2:1 or less.
- ( ) The output connector provided is an SO-239. For connection of your antenna, you will need a PL-259 plug.

## FRONT PANEL CONTROLS AND FUNCTIONS:

ON-OFF Switch . . . . . Controls 120V AC power to amplifier.  
AM-FM & SSB Switch . . . . . Adjust delay constant of automatic antenna relay.

XMT-Standby Switch . . . . . Activates the automatic antenna relay circuit, also supplies power to the receive amplifier circuit.

Receiver Amplifier ON-OFF Switch . . . . . Activates the integrated circuit receive amplifier.

NOTE: Receive amplifier will only operate when the XMT-Standby switch is in the XMT position.

RED Indicator Light . . . . . Visual indication of applied 115 V AC power.

Output Meter . . . . . Visual indication of relative RF power output.

Tune Control . . . . . Adjusts resonant frequency of amplifier.

Load Control . . . . . Adjusts coupling of output circuit to antenna.

## OPERATION:

### WARNING

WHEN THE AMPLIFIER IS USED IN THE BUSINESS BAND, ADJUSTMENTS MUST BE MADE ONLY BY A FCC LICENSED TECHNICIAN.

The 482 Bi-Linear Amplifier is factory adjusted for the range 25-32 MHz. Operation over the range 32-40 MHz requires a change in the number of turns in L1 (RF Tank Coil). A shorting tap is placed on the end of the coil, from the left-hand side as viewed from the front panel (see fig. 2) to the first turn, counting from the left side.

This Amplifier must be used with a transmitter or transceiver capable of at least one watt output.

Remove Controls cover for tuning and loading.

Install knobs supplied in separate parts pack. Fully mesh both the Tune and Load Capacitors, then install the small knob on the Tune and the big knob on the Load capacitor shaft, insuring that the marking on the knobs are horizontal and pointing to the left when viewed from the front.

## TUNING FOR AM USE:

First place the function switch in the AM-FM position. Set the tune control in accordance with the warning on page 3 of the manual. The load control should be positioned so that the capacitor is fully meshed,

Now push the ON-Off switch to ON. The red visual indicator light will light.

After warm-up, push the XMT-Standby to XMT. This will energize the automatic antenna relay control circuitry, and provide power for the integrated circuit receive amplifier.

Apply drive power by keying the exciter (transceiver) microphone and quickly adjust the tune control for maximum deflection on the output meter. Remove drive power after adjustment.

### NOTE

*Do not apply drive power for more than five seconds without adjusting the tune control or damage to the tubes can result.*

Reapply drive power and advance (clockwise) the load control, note the increase in deflection of the output meter. Adjust the load control for maximum output. Remove drive power.

### NOTE

*Readjustment of the tuning and loading controls several times will produce maximum output.*

To provide for the extra power contained in the AM signal modulation it is necessary to "overcouple" the output circuit. This is necessary to insure an undistorted output with a minimum of adjacent channel "bleeding" (spatter).

Reapply drive power and advance the load control until the output meter drops perceptably, (about 15 per cent more rotation). Readjust the tune control for maximum output. The output circuit is now "overcoupled".

If a relative power output indicator is available (SWR bridge on forward, etc.) the output signal can be quickly checked to insure upward modulation. If the meter does not "flick" upward on voice peaks, the load control is improperly set (or the exciter is not capable of 100 per cent modulation or may have "downward modulation"). Also seen on output meter.

Always the last adjustment should be the tune control.

Your amplifier is now tuned and ready for operation.

Automatic antenna change over and amplifier operation is provided for by a special transistorized input sensing circuit. Should you desire to hold the amplifier in a "ready" condition but not use it until needed, simply place the XMT-Standby in the standby position. The sensing circuit will be disabled and the antenna connected to the exciter (transceiver) at all times.

### IMPORTANT

With the XMT-Standby switch in the standby position, the REC AMP switch should be in the OFF position. This will prevent the receive amplifier loading the transceiver output.

## TUNING FOR FM:

The amplifier is tuned for FM service in a manner identical to AM except the load and tune controls are set for maximum output.

## TUNING FOR SSB & DSB:

Place the function switch in the SSB position. This will connect a delay circuit to the automatic relay control and extend the "drop-out" approximately one second. This will prevent relay "chattering" and erratic operation.

If the exciter (transceiver) is capable of carrier output equal to the peak power of the voice SSB or DSB signal, simply adjust the tune and load controls for maximum deflection of the output meter while applying carrier.

If the exciter (transceiver) cannot supply a carrier equal to peak power of the voice SSB or DSB signal then the tune and load controls must be set for maximum output while modulating. In this case, a modulation envelope indicator (monitor scope) is the most reliable method for adjustment of the amplifier.

SCHEMATIC LEGEND FOR PRODUCT 482

SYMBOL	DESCRIPTION	SYMBOL	DESCRIPTION
C2, 29, 30, 8, 28, 20	2200 $\mu\mu$ F 1KV Disc Ceramic	C31	240 pF SM
C1	150 $\mu\mu$ F 1KV Disc Ceramic	R7, 13	33 $\Omega$ 1/4W Resistor
C9	56 $\mu\mu$ F 1KV Disc Ceramic	R8	2200 $\Omega$ 1/4W Resistor
C7	50 $\mu\mu$ F 1KV Disc Ceramic	R9	10 $\Omega$ 1W Resistor
C14	20 $\mu\mu$ F 1KV Disc Ceramic	RFC1, 3	Ohmite Z-144 Choke
C12, 24, 15, 16, 23	6800 $\mu\mu$ F 1KV Disc Ceramic	RFC2	47 $\mu$ H Choke
C19	3300 $\mu\mu$ F 3KV Disc Ceramic	RFC4	Ohmite Z -28 Choke
C4, 5, 13	1000 $\mu\mu$ F 1KV Disc Ceramic	V1, 2	6JU6 Vacuum Tube
C27	100 $\mu\mu$ F Silver Mica	Q1	MPS6516 Transistor
C21	10 $\mu$ F 25-35 WVDC Electrolytic	Q2	2N696 Transistor
C11, 10	40 $\mu$ F 450V Electrolytic	C3	100 pf 1KV Disc Ceramic
C22, 26	500 $\mu$ F 15VDC Electrolytic	L1	Tank Coil
C25	.01 $\mu$ FD 1KV Disc Ceramic	L2, 3	.56 $\mu$ H Coil
C17	10.5 - 313.9 $\mu\mu$ F Air Variable	N1	#53 12-15V Lamp
C18	3.2 -50 $\mu\mu$ F Air Variable	F1	3 Amp Fuse
D1, 2	1N5054 Diode	T1	Transformer
D3	1N645 Diode	K1	3 PDT 12VDC Relay
D5, 6	1N270 Diode	K2	SPDT 12VDC Relay
D7	6.2V Zenner Diode	S1, 2, 3	SPST Switch 10 Amp
R1, 2	270K $\Omega$ 1W Resistor	IC 1	MC1550/G Integrated Circuit
R3	510 $\Omega$ 1/4W Resistor	S4	DPST Switch
R4, 10	1200 $\Omega$ 1/4W Resistor	R12	4.7K $\Omega$ 1/2W Resistor
R5	330 $\Omega$ 1/2W Resistor	M1	Relative Power Meter
R6	270 $\Omega$ 1/4W Resistor	D8	1N34 Diode
		R11	10K $\Omega$ 1/2W Resistor
		L4-5	Filter Coil
		C30-32	180 pF SM

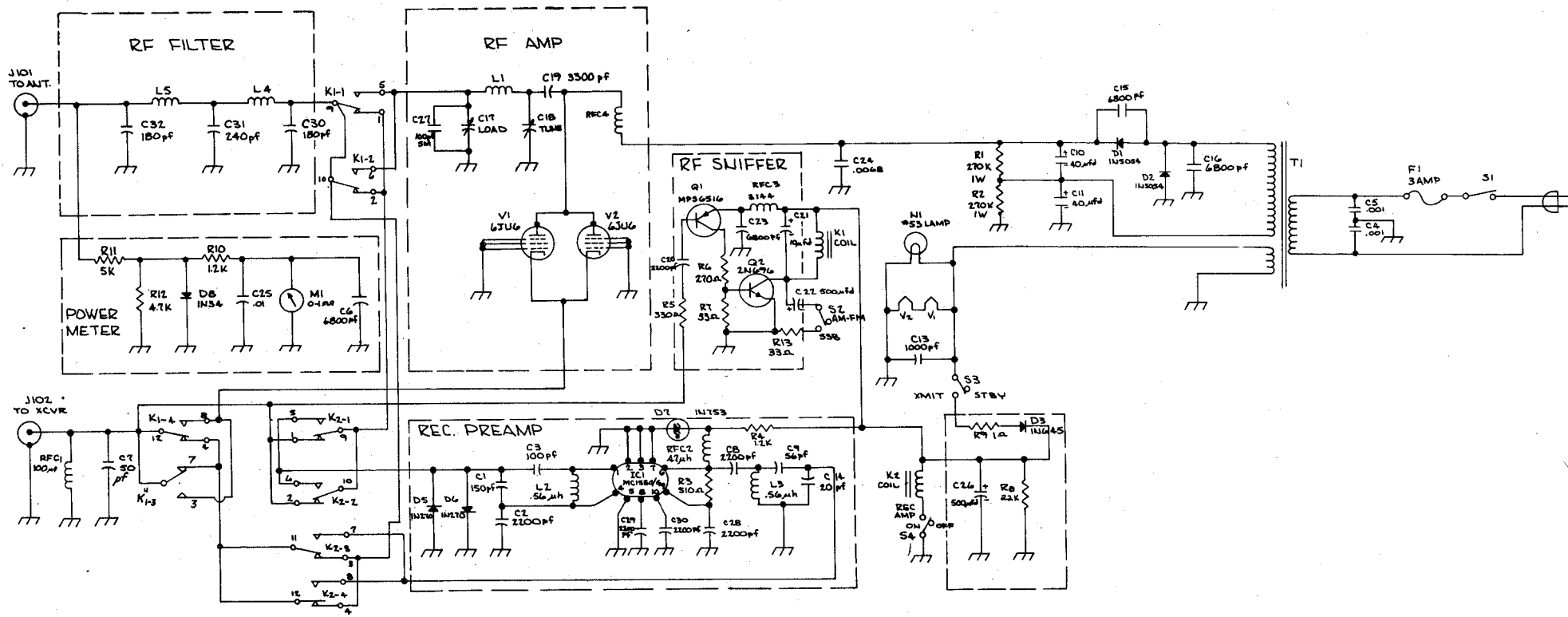

SCHMATIC DIAGRAM

## TUNING FOR CW:

(continuous wave telegraphy)

Place the function switch in the SSB position, apply drive power, and adjust the tune and load controls for maximum output.

The delay circuit for SSB prevents "drop-out" of the automatic antenna relay between characters.

Remove knobs and replace controls cover before putting the Amplifier into business radio service.

## 50-54 MHz OPERATION:

For operation on the six meter amateur band it is necessary to short out three turns from the left hand side as viewed from the front panel of the Pi-network output coil, L1. The 100pf silver mica capacitor across C17 load capacitor, must be removed.

The low pass filter on the output must be shorted out. This can be done by soldering a wire from the input to the output and removing the three silver mica capacitors (180pF and 240pF) from the small circuit board connected to the output socket.

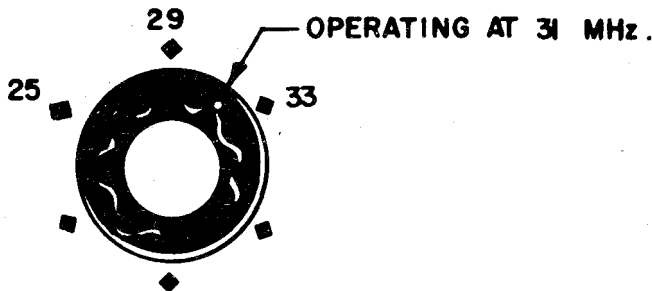

FIGURE 1 TUNE CONTROL KNOB

### WARNING

Before applying any RF power to the Linear, pretune the tune control to the desired frequency at which you wish to operate. See illustration on this page.

For example, if your desired operating frequency is 31 MHz then set the tune knob at midpoint between 29 and 33 as shown.

### NOTE

For operation on the 50 to 54 MHz band set tune control to the 29 MHz position as shown above. Then refer to the 50 to 54 MHz Operation.

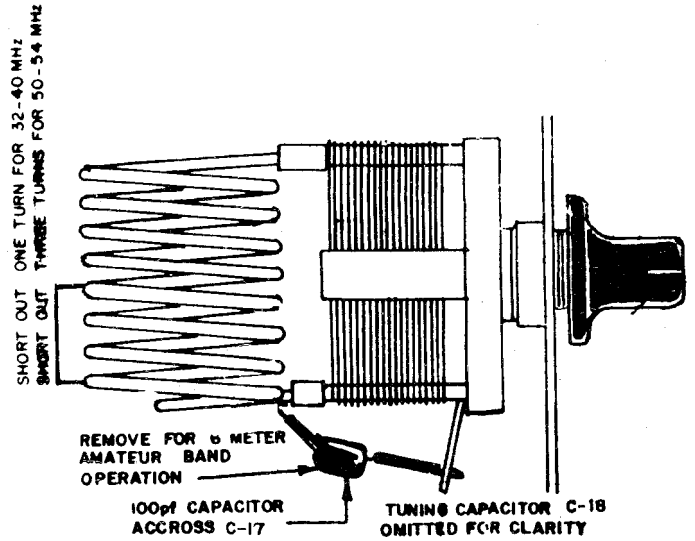

FIGURE 2

## CIRCUIT ANALYSIS:

A portion of the incoming circuit is coupled to the base of Q1 sensing transistor. This causes Q1 to conduct and change the bias on Q2, relay transistor. Q2 conducts heavily and closes relay K1.

Relay K1 connects the input signal to the cathodes of V1 and V2, applies plate voltage to V1 and V2, and connects the output circuit to the antenna.

C18 is the Pi-net tune capacitor and sets the operating frequency of the amplifier.

C17 is the Pi-net load capacitor and controls the coupling to the antenna.

For SSB operation, C22 is added to the relay transistor circuit to extend the "drop out" time.

An integrated circuit amplifier increases the level of the incoming signals from the antenna before it is applied to the transceiver. This amplifier is powered by the XMT-Standby switch and the REC AMP switch. With the XMT-Standby switch in the XMT position the receive amplifier can be switch ON or OFF as required. With the switch in the standby position, the receive amplifier is disabled and the receive amplifier switch should be in the OFF position.

## WARRANTY POLICY

The manufacturer guarantees to remedy for a period of 90 days from the date of purchase any defect in material or workmanship existing in this model at no cost to the owner, exclusive of shipping charges, provided:

1. The defect is not the result of misuse, neglect, accident, incorrect wiring not our own, improper installation or use contrary to instructions.
2. The unit serial number has been registered by the original purchaser.
3. The unit or part that appears defective is delivered prepaid to the manufacturer or authorized service center that we may designate.
4. Examination discloses, in our judgement, a defective part or workmanship.

This warranty does not extend to any units which have been repaired or altered outside of our factory nor to cases where the serial number has been removed, defaced or changed.

All labor, tubes, semi-conductors and other parts are included in this warranty. Any transportation costs, or similar charges, that may be incurred are not included. The manufacturer's sole liability is the repair at no charge of any defect for the period stated.

This written warranty is in lieu of all warranties expressed or implied and no representative or person is authorized to assume for us any other liability in connection with the sale of our products.

The manufacturer reserves the right to make any changes deemed necessary or desirable to improve the product without incurring obligation to make (or furnish parts for) like changes in units previously manufactured or sold.

All Warranties are void one year after the last model has been manufactured.

