



ORDER NO.
488

INSTALLATION & OPERATION INSTRUCTIONS

BI-LINEAR RF DECK

HY-GAIN ELECTRONICS CORPORATION
Rural Route 3 Lincoln, Nebraska 68505

SECTION I GENERAL DESCRIPTION

1.1 INTRODUCTION:

The Hy-Gain Model 488 Bi-Linear Amplifier is a precision built, compact amplifier of advanced design. It utilizes an integrated circuit, two tubes, two transistors, two diodes and a ground grid, tuned plate circuit for amplification for AM, FM, CW and SSB signals.

A special feature of the Amplifier is its dual-purpose versatility. It requires an external power supply, either an AC supply for base station use or a DC Supply for mobile station use. This, together with a quick-release mobile mount, allows the Amplifier to be easily transported between base and mobile stations.

The Amplifier has an automatic antenna change over relay which operates without special external connections, making it perfect for operation with low power transceivers having no external amplifier control circuits.

This unit amplifies the received signal, utilizing an integrated circuit amplifier. Variable plate tune and load capacitors offer impedance matching for maximum output to varying antenna loads in the 40-70 ohm range.

The Amplifier has been designed and constructed to suppress radiation that may cause television interference. TVI problem has been given full consideration in design and layout of the chassis.

There are, however, some types of TVI that cannot be prevented within the amplifier. This is particularly true in weak signal areas. In such cases, a good commercial low pass filter is recommended.

The Amplifier will operate over the frequency range 25-54 MHz. However, it is FCC Type Accepted under Parts 89, 91, and 93 over the frequency range 25-40 MHz.

Operation of this equipment requires a FCC license. Failure to comply is punishable by penalties set forth in the Rules and Regulations of the FCC. A copy of these Rules is available from the U.S. Government Printing Office and should be in the possession of the operator.

The Model 488 Bi-Linear Amplifier complies with FCC regulations when shipped from the factory, provided it is used with a Hy-Gain Model 489 DC Mobile Power Supply or a Hy-Gain Model 490 AC Power Supply and a transceiver which is FCC Type Accepted under Parts 89, 91 and 93.

1.2 TECHNICAL SPECIFICATIONS:

MECHANICAL:

Height	3"
Width	7 1/8"
Depth	8 3/4"
Net Weight	3 lbs.
Shipping Weight	4 1/4 lbs.
Construction	Lightweight aluminum chassis with rugged steel case

ELECTRICAL:

Frequency Range	25-54 MHz*
Types of Emission	AM, FM, CW, SSB, DSB#
Power Output (Slightly less at 50 MHz)	220 Watts PEP, SSB, or DSB 80 Watts CW (with 3.5 watts drive)
Amplification of Received Signal	20 db
Drive Required to Trigger Antenna Relay	1 Watt
Max Drive (unmodulated carrier and FM)	15 Watts (amplitude modulated carrier) 3.5 watts (amplitude modulated peak) 14 watts PEP
Harmonic Suppression	suppressed more than 60db
Input Impedance (unbalanced)	50 Ohms nominal, less than 2 : 1 VSWR 25-54 MHz
Output Impedance (unbalanced)	50 Ohms nominal, Adjustable 40-70 ohms, nonreactive
Antenna Switching	Automatic provided by RF sensing network
Tube and Semiconductor Complement	2 Tubes 2 Transistors 1 Integrated Circuit
Power Requirements	800V DC at 200 ma 12V AC or DC at 2 amps (obtained from either Model 489 Mobile DC Power Supply or a Model 490 Base AC Power Supply)
Cable Connector Data	Input and Output require MIL PL-259

*FCC Type Accepted for frequency range 25-40 MHz only.

#FCC Type Accepted for AM use only.

SECTION II

2.1 UNPACKING:

Carefully remove the power supply from the carton. Examine it closely for signs of shipping damage. If inspection shows damage the delivering carrier must be contacted immediately and a claim filed.

The responsibility for safe delivery rests with the carrier. The responsibility in obtaining reimbursement rests with you. Prompt action

will speed adjustments. Our warranty does not cover malfunction or damage which is a result of improper handling by a carrier.

2.2 WARRANTY REGISTRATION:

Fill out the enclosed Warranty Card and mail immediately.

SECTION III INSTALLATION AND OPERATION

3.1 The location of the mounting is not critical, but consideration must be given to provide adequate ventilation. The amplifier may be used as either a base or mobile station when used with the appropriate power supply.

When used as a mobile station the amplifier may be mounted under the dash using a Hy-Gain Model 494 quick release mobile mounting bracket and the Model 489 DC Power Supply clipped onto the rear of the amplifier.

For base station operation use the Hy-Gain Model 490 AC Power Supply.

Follow the instructions furnished with the power supply for proper installation.

A length of RG-58/U coaxial cable should be installed between the transceiver and the XCVR socket (bottom) on the Amplifier, connect an antenna to the ANT socket (top) on the Amplifier. The Antenna should have a VSWR of less than 2 : 1 for best performance of your communication system.

IMPORTANT

It is recommended to put an additional fuse close to the battery. This prevents battery damage should the connecting cable develop a short circuit between the battery and the amplifier.

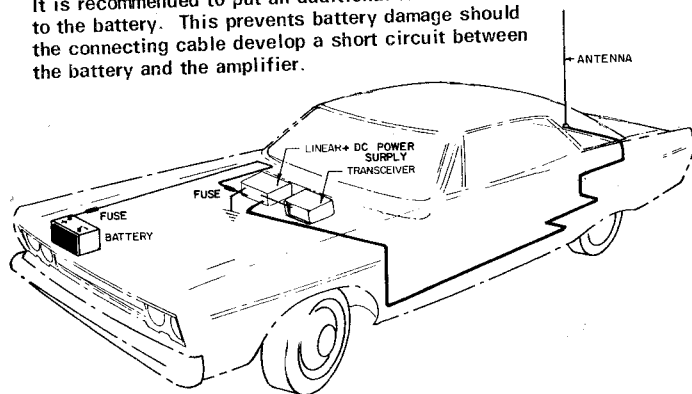

3.2 CONTROLS AND FUNCTIONS:

- ON-OFF Switch..... Controls power to amplifier
- AM-FM & SSB Switch Adjusts delay constant of automatic antenna relay
- XMT-Standby Switch..... Controls the automatic antenna relay circuit and also supplies power to the receive amplifier circuit.
- Rec Amp ON/OFF Switch Controls the integrated circuit receive amplifier.

NOTE: An integrated circuit amplifier increases the level of the incoming signals from the antenna before it is applied to the transceiver. This amplifier is controlled by the XMT Standby switch and the REC AMP switch. With the XMT Standby switch in the XMT position the receiving amplifier can be switched ON or OFF as required. With the switch in the Standby position, the receive amplifier is disabled and the receive amplifier switch should be in the OFF position.

Output Meter..... Visual indication of relative RF power output.

The side controls are for tuning and loading of the output circuit. Tune control (Bottom) adjusts resonant frequency of amplifier, the load control (Top) adjusts coupling of output circuit to antenna.

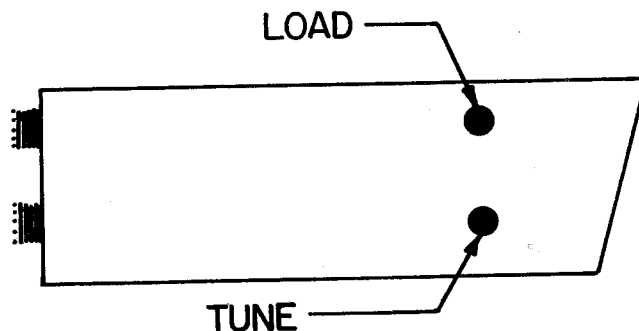

WARNING

WHEN THE AMPLIFIER IS USED IN THE BUSINESS BAND, ADJUSTMENTS MUST BE MADE BY A FCC LICENSED TECHNICIAN.

3.3 USAGE ABOVE 32 MHz TO 40 MHz:

The 488 Bi-linear Amplifier is factory adjusted for the range 25-32 MHz. Operation over the range 32-40 MHz requires a change in the number of turns in (RF Tank Coil). A shorting tap is placed on the end of the coil at the top to the first turn down.

This Amplifier must be used with a transmitter or transceiver capable of at least one watt output.

3.4 TUNING FOR AM USE:

Place the function switch in the AM-FM position. The load control should be positioned so that the capacitor is fully meshed (screw counter clockwise until tight).

Push the ON-OFF switch to ON. The meter illumination light will come on. After warm-up, push the XMT Standby to XMT. This will energize the automatic antenna relay control circuitry, and provide power to the integrated circuit receive amplifier.

Apply drive power by keying the exciter (transceiver) microphone and quickly adjust the tune control for maximum reading on the output meter. Remove drive power after adjustment.

NOTE

Do not apply drive power for more than five seconds without adjusting the tune control or damage to the tubes can result.

Reapply drive power and advance (clockwise) the load control, note the increase in reading of the output meter. Adjust the load control for maximum reading of the output meter. Now go back to the tune control and reset for maximum output. Remove drive power.

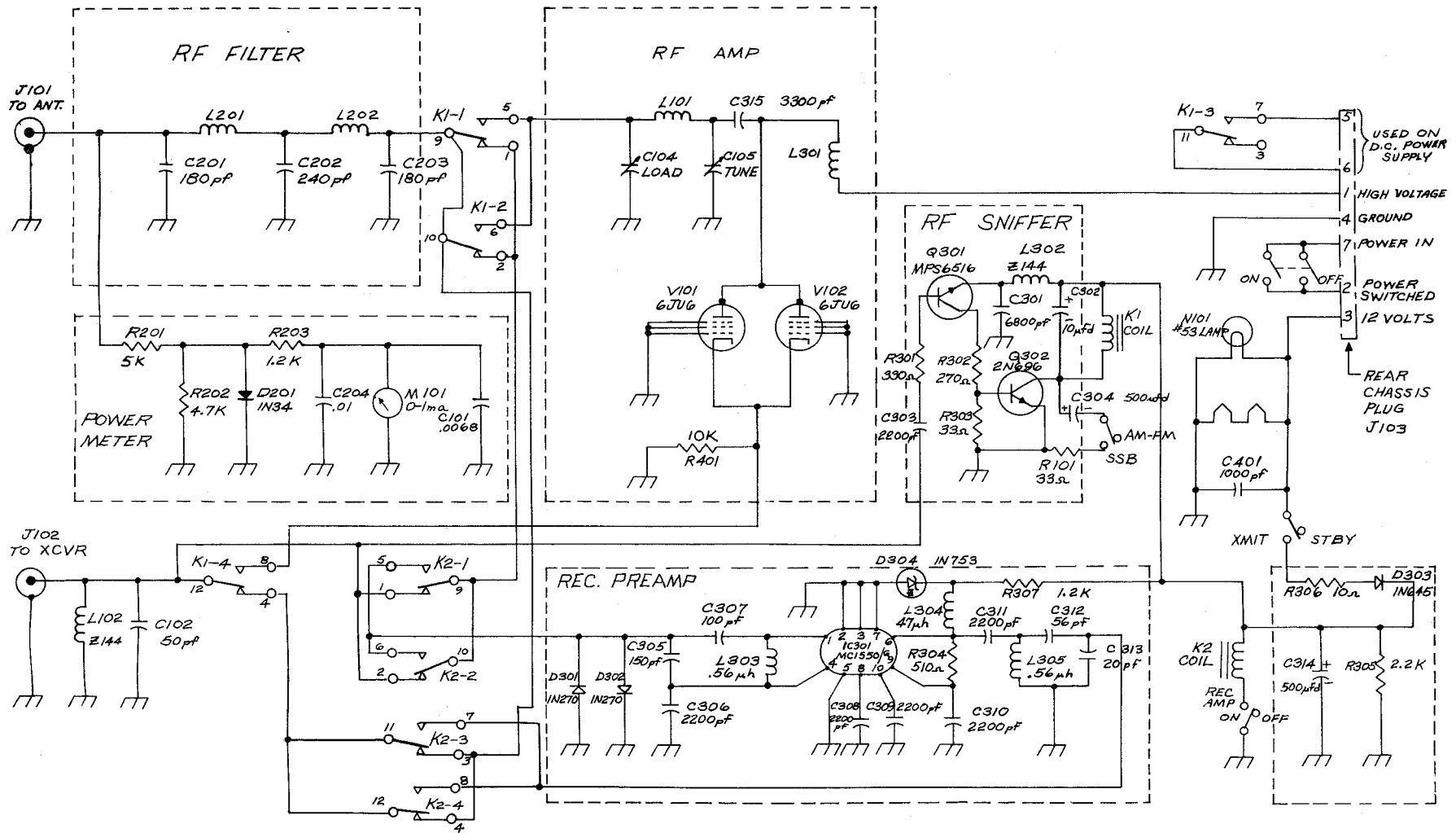

5. ALL SERIES 400 COMPONENTS ARE MOUNTED ON THE POWER BOARD ASSY.
 4. ALL SERIES 300 COMPONENTS ARE MOUNTED ON THE RELAY BOARD ASSY.
 3. ALL SERIES 200 COMPONENTS ARE MOUNTED ON THE LFF ASSY.
 2. ALL SERIES 100 COMPONENTS ARE CHASSIS MOUNTED.
 1. ALL RELAY CONTACTS ARE SHOWN IN RELAXED POSITION
- NOTES:

To provide for the extra power contained in the AM signal modulation it is necessary to "overcouple" the output circuit. This is necessary to insure an undistorted output with a minimum of adjacent channel "bleeding" (spatter).

Reapply drive power and advance the load control until the output meter drops perceptibly. Readjust the tune control for maximum output. The output circuit is now "overcoupled".

If the meter does not "flick" upward on voice peaks, the load control is improperly set (or the exciter is not capable of 100 per cent modulation or may have "downward modulation").

The tune control will always be the last adjustment.

The amplifier is now tuned and ready for operation.

Automatic antenna change over operation in the amplifier is provided by a special transistorized input sensing circuit. Should you desire to hold the amplifier in a "ready" condition, but not use it until needed, simply place the XMT-Standby switch in the Standby position. The sensing circuit will be disabled and the antenna connected to the exciter (transceiver) at all times.

3.5 TUNING FOR FM:

The amplifier is tuned for FM service in a manner identical to AM except the load and tune controls are set for maximum output.

3.6 TUNING FOR SSB & DSB:

Place the function switch in the SSB position. This will connect a delay circuit to the automatic relay control and extend the "drop-

out" approximately one second. This will prevent relay "chattering" and erratic operation.

If the exciter (transceiver) is capable of carrier output equal to the peak power of the voice SSB or DSB signal, simply adjust the tune and load controls for maximum deflection of the output meter while applying carrier.

If the exciter (transceiver) cannot supply a carrier equal to the peak power of the voice SSB or DSB signal then the tune and load controls must be set for maximum output while modulating. In this case, a modulation envelope indicator (monitor scope) is the most reliable method for adjustment of the amplifier.

3.7 TUNING FOR CW:

(continuous wave telegraphy)

Place the function switch in the SSB position, apply drive power, and adjust the tune and load controls for maximum output.

The delay circuit for SSB prevents "drop out" of the automatic antenna relay between characters.

3.8 50-54 MHz AMATEUR OPERATION:

For operation on the amateur six-meter band it is necessary to put a shorting tap on the tank coil three turns from the top down.

The low pass filter on the output must be shorted out. This can be done by soldering a wire from the input to the output and removing the three silver mica capacitors (180pF and 240 pF) from the small circuit board connected to the output socket.

SECTION IV SERVICE INFORMATION

4.1 RETURNING EQUIPMENT FOR SERVICE:

DO NOT ship equipment to the Manufacturer without prior authorization. We prefer to send special shipping labels which will avoid the delay of unexpected shipment.

If time is extremely important, wire or call for approval and we will rush labels to you. When a shipment is expected, even the time of sending the labels is less than that lost when an unexpected shipment is received.

It is VERY IMPORTANT that the shipment be well packed and fully insured. Damage claims must be settled between you and the carrier and will greatly delay any returns. Proper packing normally avoids this trouble.

ALL SHIPMENTS MUST BE SENT TO US PREPAID. We do not accept collect shipments. All returns should be made in our standard cartons only — so save your carton when unpacking the unit. When a shipment is returned it will be handled in one of three ways

1—Where all service is in warranty the shipment will be returned prepaid by a carrier of our choice.

2—If there are any charges not covered by warranty we will hold the shipment and advise you of costs, which you can then send.

3—Or, upon your written authorization, we will ship C. O. D. for any charges not covered by warranty, then the carrier will collect these charges and the transportation costs on arrival. Unclaimed or refused C. O. D. shipments will not be reshipped until payment of service and transportation charges is received. Shipment will then be made collect for reshipment transportation charges. Unclaimed equipment automatically becomes the property of the Manufacturer

60 days after date of refusal or return and will be disposed of for payment of charges due.

NOTE

We WILL NOT ship by means of a carrier that will not fully insure the shipment. Some carriers have a \$200.00 limit. The exception to this is when there is no other means (APO-FPO-etc.) of shipment than parcel post, and then we will ship by this means with your written agreement that you assume any loss over that which the carrier will insure. C. O. D. shipments cannot be made to APO-FPO addresses.

4.2 REPLACEMENT PARTS ORDERING:

All replacement parts orders must be prepaid or C. O. D. only.

Replacement part price quotes will be furnished on request for those who desire prepaid shipment or cannot accept C. O. D. shipments.

4.3 SHIPPING ADDRESS:

All requests, inquiries, warranty claims or equipment returns should be made to:

Hy-Gain Electronics Corporation
Rural Route 3
Lincoln, Nebraska 68505

Attn: Customer Service Manager

SECTION V

WARRANTY

Hy-Gain Electronics Corporation warrants each new product manufactured to be free from defects in material and workmanship and agrees to remedy any such defect, or to furnish a new part, in exchange for any part of any unit which under normal installation, use, and service discloses such defect within ninety days from the date of purchase by original owner. The unit serial number must be registered by the original owner at the time of purchase to validate the warranty.

This warranty does not extend to any of our products which have been subjected to mis-use, neglect, accident, incorrect wiring not our own, improper installation or to use in violation of instructions furnished by us. Nor does it extend to units which have been repaired or altered outside of our factory not to accessories used therewith not of our own manufacture, nor to any cases where the serial number has been removed, defaced, or changed.

Hy-Gain Electronics Corporation reserves the right to make any changes deemed necessary or desirable without advance notice or incurring any obligation to make like changes in units previously manufactured or sold.

This warranty does not cover transportation or installation costs that may be incurred. Hy-Gain Electronics Corporation's sole liability is the remedy of any defect for ninety days. Hy-Gain Electronics Corporation is not responsible for personal injury or property damage resulting from improper or careless installation not intended by the manufacturer.

No person is authorized to assume for us any other liability in connection with the sale of our products.

All warranties are void and terminated one year after the last unit of its type and design has been manufactured by us.

TYPICAL MOBILE SET-UP

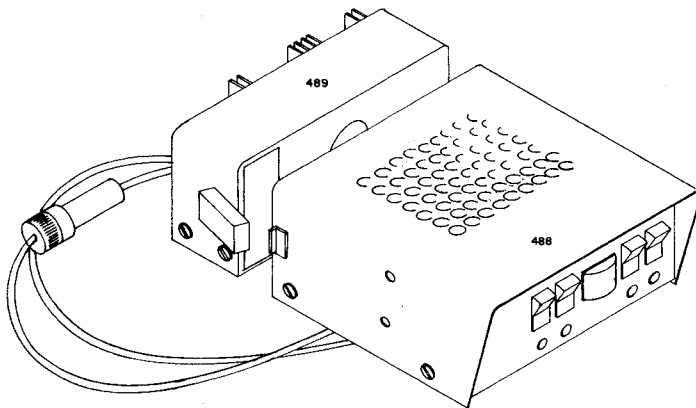

TYPICAL BASE STATION SET-UP

