



**ORDER NO.
640**

INSTALLATION & OPERATION INSTRUCTIONS

FOOTLOCKER AMATEUR RADIO LINEAR AMPLIFIER

SECTION I GENERAL DESCRIPTION

1.1 INTRODUCTION

The Footlocker Linear Amplifier is a precision built amplifier of advanced design. It utilizes two tubes, six transistors in a tuned grid tuned plate circuit for amplification of AM, FM, CW and SSB signals.

The Footlocker is designed for 12 DC negative ground mobile installation and is supplied with a remote ON/OFF switch which allows the operator to trunk-mount the Footlocker.

The Footlocker has a built-in automatic antenna change over relay, which operates without special external connections, making it perfect for operation with low power transceivers having no external amplifier control circuits.

The Footlocker has been designed and constructed to suppress radiation that may cause television interference. TVI problem has been given full consideration in the design and the layout of the chassis. There are, however, some types of TVI that cannot be prevented within the amplifier. This is particularly true in weak signal areas. In such cases, a good commercial low pass filter is recommended.

1.2 TECHNICAL SPECIFICATIONS

Mechanical

| | |
|------------------------------|---|
| Height (including feet)..... | 5 9/16" |
| Width..... | 14" |
| Depth..... | 11 1/2" |
| Net Weight..... | 9 lbs. |
| Shipping Weight..... | 10 lbs. |
| Construction..... | Lightweight aluminum chassis with rugged steel cover |

Electrical

| | |
|--|---|
| Frequency Range..... | Amateur 10 meter band |
| Types of Emission..... | AM, FM, CW, SSB, DSB |
| Power Output..... | 200 watts AM with full upward modulation |
| Drive Required to Trigger Antenna Relay..... | 1 watt |
| Max Drive (unmodulated carrier and FM)..... | 5 watts |
| (amplitude modulated carrier)..... | 3.5 watts |
| (amplitude modulated peak)..... | 14 watts PEP |
| Input Impedance (unbalanced)..... | 50 ohms nominal |
| Output Impedance (unbalanced)..... | 50 ohms fixed |
| Antenna Switching..... | Automatic provided by RF sensing circuit |
| Power Requirements..... | 13.6 volts (12v nominal) 50 amps |
| Cable Connector Data..... | Input & Output requires PL-259 |

SECTION II UNPACKING

2.1 UNPACKING

Carefully remove the Footlocker Amplifier from the carton. Examine it closely for signs of shipping damage. If inspection shows damage, the delivering carrier must be contacted immediately and a claim filed.

The responsibility for safe delivery rests with the carrier. The responsibility of obtaining reimbursement rests with

you. Prompt action will speed adjustment. Our warranty does not cover malfunction or damage which is a result of improper handling by a carrier.

2.2 WARRANTY REGISTRATION

Fill out the enclosed Warranty Card and mail immediately.

SECTION III INSTALLATION

3.1 LOCATION

The location of the mounting is not critical, however, the Footlocker was designed to be mounted on the floor of the trunk. Four support legs are provided to secure the Footlocker to the trunk floor. These support legs attach to the Footlocker by means of the screws that hold the feet on. Unscrew the feet, put the support legs on the screws and put the feet back on.

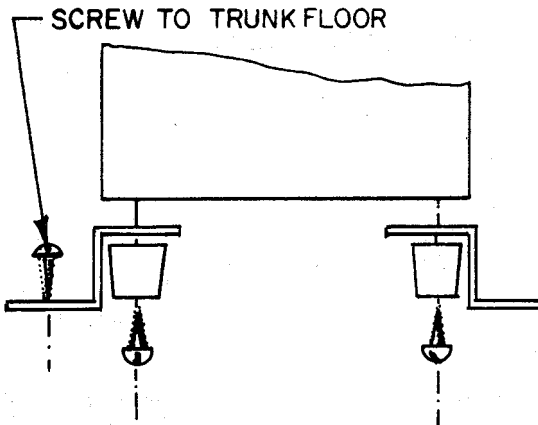

Consideration must be given to provide adequate ventilation and to enable the operator to set up and check the Footlocker when it is installed.

The Remote Switch should be mounted in a convenient position on the dash. The two wires should be routed back to the Footlocker and connected to the terminal strap marked "Remote". Make sure that the red wire goes to the red terminal and the black wire to the black terminal. A good ground should be made on the remote switch through the mounting lugs, otherwise the ON/OFF indicator lamp will not light when the Footlocker is switched to ON.

3.2 REGULATOR TEST

Before connecting the primary power cables to the supply and the battery terminals, the voltage output of the generator or alternator should be checked. Turn on the car headlights for five minutes without starting the motor. This will discharge the battery slightly. Connect an accurate voltmeter from the generator output terminal to ground and start the motor. WITH THE MOTOR AT A FAST IDLE, THE GENERATOR OR ALTERNATOR OUTPUT VOLTAGE SHOULD NOT EXCEED 14.5 VOLTS. If it does, the automotive voltage regulator should be recalibrated for a maximum output voltage from the generator or alternator of 14.5 volts. If the generator output voltage is between 13.5 and 14.5 volts, the regulator will not need adjustment. (For regulator adjustment, refer to the shop service manual for the automobile available from your car dealer.)

The Footlocker draws up to 50 amps of current when transmitting. If the electrical system of your vehicle is not capable of supplying this current at 13.6 volts, then full RF power output will not be achieved.

Connect the Footlocker directly to the vehicle battery using #6 or heavier wire for both positive and negative. The vehicle chassis is a poor ground return path at this current and should not be used. As an added safety precaution, it is strongly recommended that an additional 40 amp fuse and holder (the type obtainable from most electrical contractor supply stores) be inserted in the line directly at the positive terminal. This will protect battery should a short circuit develop in the wires going to the Footlocker.

CAUTION

OBSERVE POLARITY; positive to +12v terminal and negative to -12v terminal. REVERSING POLARITY WILL CAUSE DAMAGE TO VEHICLE AND FOOTLOCKER.

Connect a length of coaxial cable (RG 58/U or similar) between the transceiver and XCVR socket.

NOTE

The antenna system should be checked for VSWR of less than 2:1 before the Footlocker is used. For best performance of your communication system the VSWR should be as low as possible.

3.3 OPERATION

When the Footlocker is installed as outlined above, operation is simply achieved by switching the remote unit ON and OFF. This controls the Footlocker. A built-in delay in the automatic antenna change over holds the relay in for about one second. This is to prevent chatter when using SSB (single side band) transceivers.

Set the slide switch on the rear panel to the TUNE position. Adjust the drive control for midway position. Apply 3.5 watts drive power by keying the transceiver microphone and quickly adjust the tune control for maximum reading on the output meter. Remove the drive power after adjustment.

NOTE

Do not apply drive power for more than five seconds without adjusting the tune control or damage to the tubes can result.

Reapply drive power and adjust the drive control so that the amplifier produces about 100 watts (about 5-6 on the meter).

Adjustment of the input tuning coil (on the underside of the Footlocker), using a hex shaped plastic alignment tool, may be necessary to achieve maximum power output.

Set the Tune-Operate slide switch to the Operate position. Reapply drive power and adjust the drive control maximum output, readjust the Tune and Input tuning coil for maximum output.

NOTE

The load capacitor is factory adjusted to provide maximum output and should not be adjusted.

Adjust the drive control until the power output is about 150-200 watts. The amplifier is now adjusted to give 150 watts output with upward modulation to 300 watts.

NOTE

Always use a good peak reading watt meter such as the Hy-Gain 421A when adjusting an amplifier.

If the average output power decreases with modulation then either the transmitter (exciter) is incapable of upward modulation or the amplifier has not been tuned up correctly and the above procedure should be rechecked. If this does not correct the situation, the drive control (on the rear panel) should be adjusted for a slightly lower power level necessary to produce upward modulation than a carrier power of a higher level with downward modulation, this will increase your communication range and provide a clearer signal with much less distortion.

For best AM operation the linear must be tuned according to above procedures. Many misconceptions regarding linear operation exist among linear users. Reviewing a few points regarding proper linear operation will help to

provide better tune-up and communications for the user.

1. The linear amplifies the radio frequency (RF) signal.
2. If the output signal reproduced is identical to the input, except stronger, the amplifier is said to be linear. If not, the amplifier is non-linear.
3. Non-linear operation produces spurious outputs and distortion of the signal.
4. All spurious signals use up power.
5. All power used to produce distortion and spurious signals is power not being used for communication.
6. The Footlocker provides a 300 watt RF envelope maximum power output.
7. Any attempt to operate AM at the 300 watt carrier level will produce downward modulation with distortion and spurious signals.
8. Distortion and spurious signals (lost power) will occur in all linear amps of operation at maximum carrier power is attempted.
9. All linear amplifiers should be operated at about one half the maximum carrier output to allow for modulation expansion of the carrier.
10. Operation without leaving room for modulation expansion will not provide good communication. The carrier contributes nothing toward intelligibility, only good modulation can carry intelligence. Running higher carrier power and lower modulation is a detriment rather than an asset.

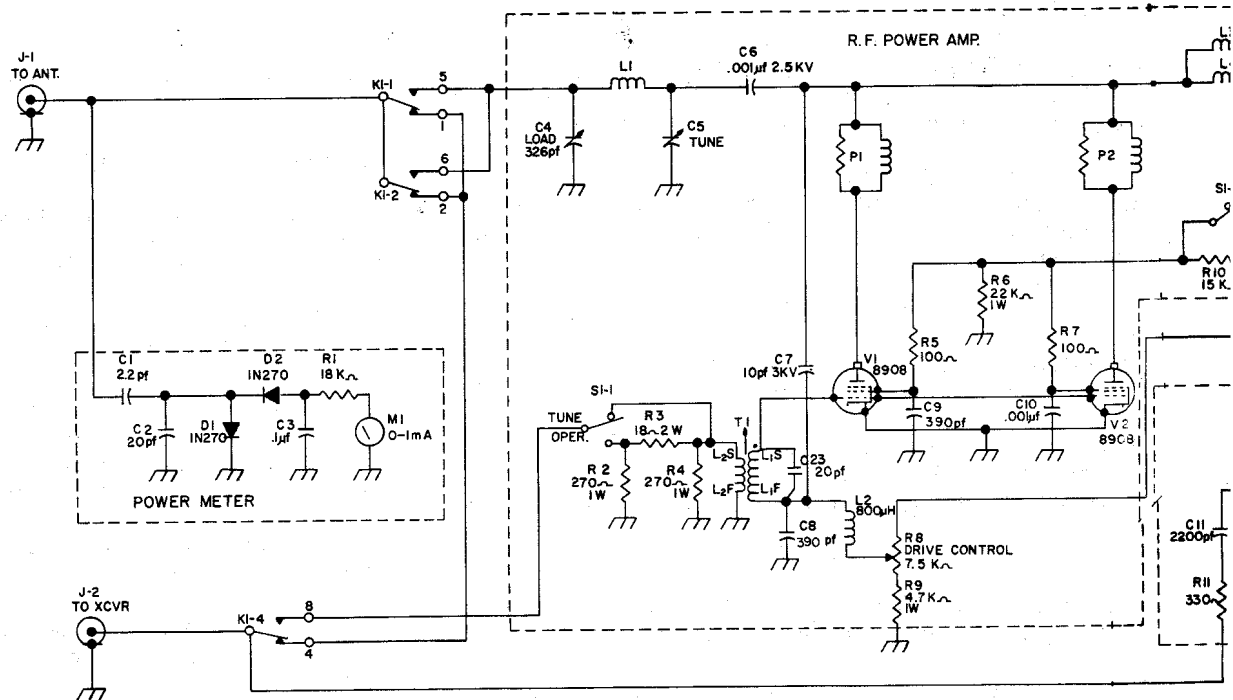

SECTION IV SERVICE INFORMATION

4.1 RETURNING EQUIPMENT FOR SERVICE

DO NOT ship equipment to the Manufacturer without prior authorization. We prefer to send special shipping labels which will avoid the delay of unexpected shipment.

If time is extremely important, wire or call for approval and we will rush labels to you. When a shipment is expected, even the time of sending the labels is less than that lost when an unexpected shipment is received.

It is VERY IMPORTANT that the shipment be well packed and fully insured. Damage claims must be settled between you and the carrier and will greatly delay any returns. Proper packing normally avoids this trouble.

ALL SHIPMENTS MUST BE SENT TO US PREPAID. We do not accept collect shipments. All returns should be made in our standard cartons only - so save your carton when unpacking the unit. When a shipment is returned it will be handled in one of three ways...

1 - Where all service is in warranty the shipment will be returned prepaid by a carrier of our choice.

2 - If there are any charges not covered by warranty we will hold the shipment and advise you of costs, which you can then send.

3 - Or, upon your written authorization, we will ship COD for any charges not covered by warranty, then the carrier will collect these charges and the transportation costs on arrival. Unclaimed or refused COD shipments will not be

reshipped until payment of service and transportation charges is received. Shipment will then be made collect for reshipment transportation charges. Unclaimed equipment automatically becomes the property of the Manufacturer 60 days after date of refusal or return and will be disposed of for payment of charge due.

NOTE

We WILL NOT ship by means of a carrier that will not fully insure the shipment. Some carriers have a \$200.00 limit. The exception to this is when there is no other means (APO-FPO-etc.) of shipment than parcel post, and then we will ship by this means with your written agreement that you assume any loss over that which the carrier will insure. COD shipments cannot be made to APO-FPO addresses.

4.2 REPLACEMENT PARTS ORDERING

All replacement parts orders must be prepaid or COD only.

Replacement part price quotes will be furnished on request for those who desire prepaid shipment or cannot accept COD shipments.

4.3 SHIPPING ADDRESS

All requests, inquiries, warranty claims or equipment returns should be made to:

Hy-Gain Electronics Corporation
8601 N.E. Highway 6
Lincoln, Nebraska 68507

Attn: Customer Service Manager

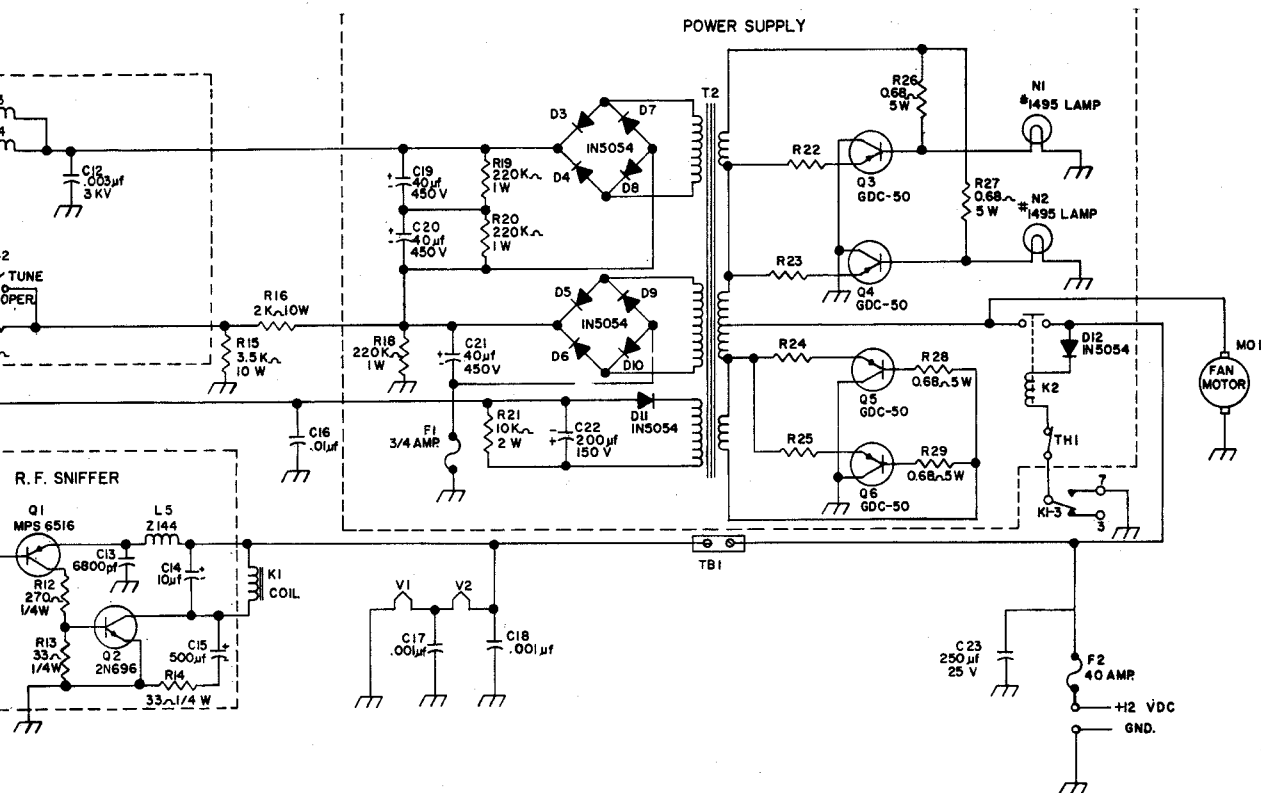

SECTION V WARRANTY

Hy-Gain Electronics Corporation warrants each new product manufactured to be free from defects in material and workmanship and agrees to remedy any such defect, or to furnish a new part, in exchange for any part of any unit which under normal installation, use, and service discloses such defect within ninety days from the date of purchase by original owner. The unit serial number must be registered by the original owner at the time of purchase to validate the warranty.

This warranty does not extend to any of our products which have been subjected to mis-use, neglect, accident, incorrect wiring not our own, improper installation or to use in violation of instructions furnished by us. Nor does it extend to units which have been repaired or altered outside of our factory nor to accessories used therewith not of our own manufacture, nor to any cases where the serial number has been removed, defaced, or changed.

Hy-Gain Electronics Corporation reserves the right to make

any changes deemed necessary or desirable without advance notice or incurring any obligation to make like changes in units previously manufactured or sold.

This warranty does not cover transportation or installation costs that may be incurred. Hy-Gain Electronics Corporation's sole liability is the remedy of any defect for ninety days. Hy-Gain Electronics Corporation is not responsible for personal injury or property damage resulting from improper or careless installation not intended by the manufacturer.

No person is authorized to assume for us any other liability in connection with the sale of our products.

All warranties are void and terminated one year after the last unit of its type and design has been manufactured by us.

PARTS LIST

| Symbol | Description | Part No. | Symbol | Description | Part No. |
|--------|--------------------------------|----------|--------|--------------------------------|----------|
| C1 | Capacitor 2.2pf Cer Disc | 721609 | Q3 | Transistor GDC-50 | 760259 |
| C2 | Capacitor 20 pf Cer Disc | 725717 | Q4 | Transistor GDC-50 | 760259 |
| C3 | Capacitor 0.1 uf Flat Film | 721574 | Q5 | Transistor GDC-50 | 760259 |
| C4 | Capacitor-Load 326 pf Variable | 720015 | Q6 | Transistor GDC-50 | 760259 |
| C5 | Capacitor-Tune 50pf Variable | 721157 | R1 | Resistor 18K Ω 1/2 watt | 721339 |
| C6 | Capacitor .001 uf 2.5 KV | 721660 | R2 | Resistor 270 Ω 1 watt | 720016 |
| C7 | Capacitor 10 pf 3KV | 721613 | R3 | Resistor 18 Ω 2 watt | 720017 |
| C8 | Capacitor .001 uf | 721158 | R4 | Resistor 270 Ω 1 watt | 720016 |
| C9 | Capacitor .390 pf | 721700 | R5 | Resistor 100 Ω 1/2 watt | 721285 |
| C10 | Capacitor .001 uf | 721158 | R6 | Resistor 22K Ω 1 watt | 721373 |
| C11 | Capacitor 2200 pf | 721161 | R7 | Resistor 100 Ω 1/2 watt | 721285 |
| C12 | Capacitor .003 uf 3KV | 721159 | R8 | Pot Linear 7.5K Ω | 721451 |
| C13 | Capacitor 6800 pf | 721160 | R9 | Resistor 4.7K Ω 1 watt | 721367 |
| C14 | Capacitor 10 uf Ele | 721121 | R10 | Resistor 15K Ω 1/2 watt | 721340 |
| C15 | Capacitor 500 uf Ele | 721120 | R11 | Resistor 330 Ω 1/2 watt | 721305 |
| C23 | Capacitor 20 pf Cer Disc | 725717 | R12 | Resistor 270 Ω 1/4 watt | 721112 |
| C17 | Capacitor .001 uf | 721158 | R13 | Resistor 33 Ω 1/4 watt | 721103 |
| C18 | Capacitor ,001 uf | 721158 | R14 | Resistor 33 Ω 1/4 watt | 721103 |
| C19 | Capacitor 40 uf 450VDC Ele | 721156 | R15 | Resistor 3.5K Ω 10 watt | 721515 |
| C20 | Capacitor 40 uf 450VDC Ele | 721156 | R16 | Resistor 2K Ω 10 watt | 721527 |
| C21 | Capacitor 40 uf 450VDC Ele | 721156 | R18 | Resistor 220K Ω 1 watt | 721383 |
| C22 | Capacitor 200 uf 150VDC Ele | 721779 | R19 | Resistor 220K Ω 1 watt | 721156 |
| D1 | Diode 1N270 | 765722 | R20 | Resistor 220K Ω 1 watt | 721156 |
| D2 | Diode 1N270 | 765722 | R21 | Resistor 10K Ω 2 watt | 721418 |
| D3-D11 | Diode 1N5054 | 765713 | R22 | Teflon Wire 6 in 22 Ga Str | 620001 |
| F1 | Fuse 3/4 amp AGC 3 AG | 710009 | R23 | Teflon Wire 6 in 22 Ga Str | 620001 |
| F2 | Fuse 40 amp AGU-40 | 710227 | R24 | Teflon Wire 6 in 22 Ga Str | 620001 |
| K1 | Relay 4 PDT | 730006 | R25 | Teflon Wire 6 in 22 Ga Str | 620001 |
| K2 | Relay SPST 12 VDC | 730238 | R26 | Resistor 0.68 Ω 5 watt | 722224 |
| L1 | Coil-Tank | 270014 | R27 | Resistor 0.68 Ω 5 watt | 722224 |
| L2 | Choke 800 uh | 721902 | R28 | Resistor 0.68 Ω 5 watt | 722224 |
| L3 & 4 | Choke-Plate | 721124 | R29 | Resistor 0.68 Ω 5 watt | 722224 |
| L5 | Coil Z144 | 728025 | S1 | DPDT Slide Switch | 700206 |
| M1 | Meter 0-1 mA Relative Power | 795680 | T1 | Coil- Input | 720018 |
| N1 | Lamp Bayonet Base #1495 | 710222 | T2 | Toroid Power Transformer | 730217 |
| N2 | Lamp Bayonet Base #1495 | 710222 | V1 | Beam Pentode Tube | 760004 |
| P1 | Parasitic Choke | 721950 | V2 | Beam Pentode Tube | 760004 |
| P2 | Parasitic Choke | 721950 | TH1 | Relay Thermal | 722167 |
| Q1 | Transistor MPS 6516 | 761115 | TB1 | Terminal Locking | 540226 |
| Q2 | Transistor 2N696 | 761114 | MO1 | Motor 12 VDC | 740004 |
| D12 | IN5054 Diode | 765713 | R30 | Resistor 33 Ω 1/4 watt | 721103 |

NOTE

For best results, always use matched pairs of type 8908 output tubes available from Hy-Gain Customer Service.