

JOHNSON ELECTRONIC EQUIPMENT

E. F. JOHNSON COMPANY
WASECA MINNESOTA

INSTRUCTION MANUAL

VIKING KILOWATT
AMPLIFIER



STANDARD WARRANTY

Adopted and Recommended by the
Radio - Electronics - Television Manufacturers Association

The E. F. Johnson Company warrants each new radio product manufactured by it to be free from defective material and workmanship and agrees to remedy any such defect or to furnish a new part, except for electron tubes, in exchange for any part of any unit of its manufacture which under normal installation, use and service disclosed such defect, provided the unit is delivered by the owner to us or to our authorized radio dealer or wholesaler from whom purchased, intact, for our examination, with all transportation charges prepaid to our factory, within ninety days from the date of sale to original purchaser and provided that such examination disclosed in our judgment that it is thus defective.

This warranty does not extend to any of our radio products which have been subjected to misuse, neglect, accident, incorrect wiring not our own, improper installation, or to use in violation of instructions furnished by us, nor extend to units which have been repaired or altered outside of our factory, nor to cases where the serial number thereof has been removed, defaced or changed, nor to accessories used therewith not of our own manufacture, nor to electron tubes.

Defective electron tubes and executed service report should be returned prepaid directly to the tube manufacturer for adjustment at the following addresses:

(a) RCA tubes to: Adjustment Service, RCA at the nearest of the following addresses:

34 Exchange Place Jersey City 2, N. J.	589 East Illinois Street Chicago 11, Illinois	420 So. San Pedro St. Los Angeles 13, Calif.
-------------------------------------------	--------------------------------------------------	-------------------------------------------------

(b) General Electric tubes to: (c) Eimac tubes to: (d) Amperex tubes to:

Adjustment Service Owensboro Tube Works General Electric Company Owensboro, Kentucky	Distributor from whom Kilowatt Amplifier was purchased or Eitel-McCullough, Inc. 798 San Mateo Avenue San Bruno, Calif.	Amperex Electronic Corp. 230 Duffy Avenue Hickville, Long Island, New York
-----------------------------------------------------------------------------------------------	-------------------------------------------------------------------------------------------------------------------------------------------	-------------------------------------------------------------------------------------

Any part of a unit approved for remedy or exchange hereunder will be remedied or exchanged by the authorized radio dealer or wholesaler without charge to the owner.

This warranty is in lieu of all other warranties expressed or implied and no representative or person is authorized to assume for us any other liability in connection with the sale of our radio products.

N - O - T - I - C - E

OPERATION OF THIS KILOWATT POWER AMPLIFIER SHOULD NOT BE ATTEMPTED UNTIL THIS MANUAL HAS BEEN READ CAREFULLY AND IS FULLY UNDERSTOOD TO AVOID IMPROPER OPERATION AND POSSIBLE DAMAGE TO THE COMPONENTS.

PARTICULAR ATTENTION SHOULD BE PAID TO THE FOLLOWING PARAGRAPHS:

1. MAIN POWER LINE AND FUSES - Pages 2 and 9
2. AMPLIFIER PLATE CURRENT - Page 13
3. TUNING PROCEDURE - Page 16
4. AM MODULATOR - Page 17

C O N T E N T S

	<u>Page</u>
DESCRIPTION AND SPECIFICATIONS	
1. General Description	1
2. Mechanical Description	1
3. Electrical Description	1
4. Specifications	2
 INSTALLATION	
1. Unpacking	5
2. Location	5
3. Installation of Cabinet and Amplifier Unit	5
4. Installation of Components	6
5. RF Amplifier	8
6. Panel Frame	8
7. Top Panel Cover	8
8. Front Panel Cover	9
9. Modification, 230 to 115 Volt Power	9
10. Main Power Line and Fuses	9
11. Exciter Cables	9
12. Amplifier Output Coaxial Cable	11
13. Ground Connection	11
14. Installation of Amplifier in Cabinet	11
 CIRCUITRY	
1. Line Power Control	12
2. Plate-Screen Voltage Control	12
3. Plate Voltage Change	12
4. Overload Control	12
5. Modulator Shorting	12
6. Mode of Operation Switch	12
7. Modulator Bias	12
8. Modulator Current	12
9. Amplifier Bias	12
10. Amplifier Plate Current	13
11. Amplifier Screen Voltage	13
12. Amplifier Grid Current	13
13. Amplifier Plate Voltage	13
14. Amplifier Grid Circuit	13
15. Amplifier Screen Circuit	14
16. Amplifier Plate Circuit	14
17. No Excitation Condition	14
18. RF Filtering and Shielding	14
 ADJUSTMENT	
1. Exciter, AM-CW	15
2. Kilowatt Amplifier, AM-CW	16
3. AM Modulator	17
4. SSB Operation	17
5. General Operation	18
6. Bias, Overload and Neutralization	18
7. Kilowatt Amplifier at 25 MC	19
8. Audio Driver	19

C O N T E N T S

Page 2

	<u>Page</u>
TVI AND ANTENNA COUPLING CONSIDERATIONS	
1. Television Interference	21
2. Antenna Coupling Unit	23
3. Fast Make - Slow Break Antenna Relay System	23
MAINTENANCE	
1. Routine	25
2. Switches and Relays	25
3. Ventilation Systems	25
4. Indicator Lamps	25
5. Fuses	25
6. Gear Drive	25
7. Inductor-Capacitor Drive and Stop Assembly	25
8. Protective Ball-Gap Adjustment	26
9. Vacuum Tubes	26
10. Bias and Screen Voltages	26
PARTS LIST	27
ILLUSTRATIONS	At Rear of Manual
FIG. 1 Amplifier and Pedestal	
FIG. 2 Amplifier, Pedestal and Desk Assembly	
FIG. 3 Amplifier Frame, Right Side View	
FIG. 4 Amplifier Frame, Left Side View	
FIG. 5 Amplifier Frame, Left Forward View	
FIG. 6 Amplifier Frame, Rear View	
FIG. 7 RF Amplifier, Left Interior View	
FIG. 8 Amplifier Tuning Panel	
FIG. 9 Power Control Panel	
FIG. 10 RF Amplifier Chassis, Bottom View	
FIG. 11 RF Amplifier Tube Chassis, Bottom View	
FIG. 12 RF Amplifier, Right Rear View	
FIG. 13 RF Amplifier, Left Rear View	
FIG. 14 TABLE A - RF Amplifier Tuning Positions	
TABLE B - Ranger Exciter Tuning Positions	
FIG. 15 TABLE C - Amplifier Current and Voltage Values	
FIG. 16 Amplifier Schematic Diagram	
FIG. 17 Amplifier Tuning Calibration Chart	

C A U T I O N

Operation of this equipment involves high voltages which are dangerous to life and the operator should observe proper safety precautions at all times. Do not make adjustments inside the amplifier with the power supplies operating or short out the interlock switch. Make a habit of using a grounding hook with an insulated handle which can be placed on the high voltage terminal of the filter condenser whenever working inside the amplifier

DESCRIPTION AND SPECIFICATIONS

1. GENERAL DESCRIPTION

The Johnson Viking Kilowatt Amplifier is designed to meet modern communication's demand for a self contained r. f. amplifier capable of CW, AM, and SSB operation over a frequency range of 3.5 to 30 megacycles. The unit incorporates a complete power system and modulator in addition to an amplifier rated at 1000 watts input with provisions for reduced power on CW and AM operation. Tested engineering techniques have been applied to its design and TVI reduction.

Each unit is completely adjusted and tested on all bands at the factory before shipment is made.

2. MECHANICAL DESCRIPTION

The entire amplifier unit is housed in a desk type pedestal to which may be attached an optional operating desk, either right or left hand. The complete sizes and weights are listed in the Specifications Section.

All the equipment is mounted in a steel box frame which slides into the pedestal on ball bearing rollers thus facilitating removal for servicing of the complete unit. In addition, the r. f. amplifier is a completely shielded and filtered plug-in unit which further facilitates servicing. The rear of the pedestal contains all cable entrances, cooling fan screens and two wing screws for securely anchoring the frame.

The r. f. amplifier panel, with its controls for bandswitching and tuning is located on the top front of the pedestal within easy reach of the operator. The two meters on the panel provide convenient observation of the cathode, grid and modulation currents. When not in use, the entire amplifier panel may be concealed by a cover which is normally nested to the right of the panel, in a built-in cavity.

The power control panel is recessed behind the lower front of the pedestal and contains the filament, overload and mode of operation switches in addition to the filament fuse, screen fuse and plate voltmeter. As a precaution against accidental application of power, the filament switch, which controls the power input relay, is a key lock type. A sliding door provided behind the pedestal front may be used to conceal the panel during periods of non-operation.

Ventilation in the pedestal is accomplished by a lower intake fan and an upper exhaust fan which provide a continuous flow of forced air. In addition, the r. f. unit contains two fans for cooling the amplifier tubes.

3. ELECTRICAL DESCRIPTION

The Kilowatt Amplifier is normally wired for a 230 volt 50/60 cycle, 3 wire single phase, grounded neutral source, although it may be converted to 115 volt, 2 wire 50/60 cycle single phase service by changing the wiring of relay RY303. A three wire power line plug is provided to fit into the socket located on the power input panel at the rear of the pedestal. The exciter transmitter power and control sockets are also located on this panel. The input panel interlock switch removes the plate and screen voltages whenever the transmitter frame is withdrawn from the pedestal.

Automatic protection is provided by an adjustable overload relay operating in the cathode circuit of the final amplifier and by a thermo-delay relay providing sufficient "warm up" time for tube filaments. Panel mounted fuses are also provided in the primary of the filament, bias and screen voltage supplies for their protection. The two sides of the 3 wire power line must have their own 20 ampere fuses located either at the main fuse box or where they enter the room.

Voltage requirements for plate, screen and bias are furnished by three separate supplies each having choke input with sufficient LC values to reduce ripple voltage to a satisfactory minimum. The high voltage supply uses two 872A rectifiers, the screen supply a 5R4GY rectifier and the bias supply a 5V4G rectifier. The proper bias, screen and plate voltages for each type of operation are selected by the mode of operation switch which is located on the power control panel. Power to the transformer primaries is controlled by three relays: RY300 which controls all line power to the amplifier and exciter; RY302 which controls the plate and screen power; and RY303 which selects high or low plate voltage as determined by the mode of operation switch. The rf amplifier screen voltage is regulated on AM and SSB by voltage regulator tubes.

The class B modulator is capable of 100% amplitude modulation of the 1000 watts input of the rf amplifier. It consists of two 310 tubes and a low noise level modulation transformer protected by ball gaps mounted on the secondary terminals. The grids of the modulator tubes are driven by an external source and are connected, as is the modulator bias, through the power panel octal socket. During CW and SSB operation, the modulator is allowed to dissipate some power to improve voltage regulation and is protected from accidental overload by shorting the modulator grids and transformer secondary by means of relay RY304. A modulation choke is placed in series with the screen voltage supply during AM operation to supply the necessary screen modulating voltage.

The rf amplifier employs two parallel 4-250A tubes in a conventional circuit using a PI network output and bridge neutralization. The variable plate capacitor and inductor are ganged and gear driven from a single control for continuous tuning with a switch for disengaging the capacitor at frequencies above 13 megacycles. Output coupling is provided by a dual variable capacitor and two fixed ceramic capacitors selected by the coupling switch. The grid drive is link coupled to a continuous coverage grid circuit. The amplifier is completely shielded and filtered and employs parasitic suppressors in all rf circuits for stabilized operation. Protection against accidental application of the high voltage to the output circuit is accomplished by a drain choke in that circuit.

A 117 volt receptacle is provided, at the rear of the equipment, which can be used to power the exciter and which is energized by the key operated filament switch. Remote control of the Kilowatt Amplifier is accomplished by use of an external switch as shown in the schematic diagram. This switch is normally provided in the exciter and thus permits single switch control of both exciter and amplifier. A plate power switch (S104) located on the amplifier panel permits exciter and amplifier grid adjustments without energizing the amplifier.

4. SPECIFICATIONS

Frequency coverage (3.5 to 30 mc) 3.5 - 4.7 mcs.
 4.5 - 6.6 mcs.
 6.0 - 8.8 mcs.
 8.0 - 11.7 mcs.
 11.0 - 15.8 mcs.
 15.3 - 22.0 mcs.
 21.8 - 30.0 mcs.

Emission 1. continuous wave
 2. amplitude modulated
 3. single side band, suppressed carrier

Amplifier Input Power 1000 watts AM-HI, CW-HI, SSB
 300 watts AM-LOW, CW-LOW (TUNE)

RF Output Impedance 50 to 500 ohms nominal

RF Drive Power 30 watts max. AM-HI, CW-HI
 3 watts peak SSB

Audio Drive Power 15 watts

Audio Drive Impedance 3500 ohms grid to grid

Power Source and Demand 230 V, 3 wire, 50/60 cycle, single phase,
 grounded neutral,
 or
 115 V 2 wire 50/60 cycle single phase

500 watts, filament and bias voltage

975 watts TUNE (CW-LO) (No Excitation Condition)
 1050 watts, TUNE (CW-LO) full power

950 watts, AM-LO (No Excitation Condition)
 1225 watts, AM-LO full power

1200 watts, CW-HI (No Excitation Condition)
 2000 watts, CW-HI full power

1150 watts, AM-HI (No Excitation Condition)
 2800 watts, AM-HI full power 100% MOD.

1350 watts, SSB (No Excitation Condition)
 1950 watts, SSB average peak power 1 KW input,
 2 tone signal

Dimensions: Pedestal, 19-3/4 inches wide, 29-13/16 inches high and 32-13/16 inches deep
 Desk, 43-13/16 inches wide, 29 inches high and 32 inches deep

Weights:	Complete pedestal	403 Lbs.
	Desk	151 Lbs.
	Pedestal and desk	554 Lbs.

C A U T I O N

Operation of this equipment involves high voltages which are dangerous to life and the operator should observe proper safety precautions at all times. Do not make adjustments inside the amplifier with the power supplies operating or short out the interlock switch. Make a habit of using a grounding hook with an insulated handle which can be placed on the high voltage terminal of the filter condenser whenever working inside the amplifier.

INSTALLATION

UNPACKING

Each Viking Kilowatt Amplifier is shipped with the heavier power components and vacuum tubes removed for separate shipment. Some items such as power plugs, mounting hardware etc. are also shipped separately. When opening the crates and boxes, care must be exercised so the equipment is not damaged or identification tags are not torn loose. Inspect all boxes and packaging material to make certain no loose hardware or small boxes are discarded.

The enclosed packing list, indicating the number of boxes and their contents, may be used as a check form to account for all items.

When the uncrating is completed, inspect all units and components for loose or damaged parts. The Kilowatt Amplifier was completely checked and tested at the factory and, except for removed parts, should be in operating condition. In the event the boxes or crates show evidence of abuse, all material including crates and packaging should be retained for inspection and the transportation agency should be promptly notified of your claim for damages. Do not write the factory relative to such claims.

LOCATION

The location of the Kilowatt Amplifier will vary with individual installations but each will require consideration of the weight of the equipment and the proximity of power, antenna and ground connections. In all installations, the back of the pedestal or combined pedestal-desk must be at least 8 inches from the wall to allow movement of the ventilating air and to provide accessibility to the power-control plugs.

INSTALLATION OF CABINET AND AMPLIFIER UNIT

After the equipment has been unpacked and all packing and foreign material has been removed from the unit, the following installation procedure is recommended.

Place only the pedestal in the desired location and adjust the height and level by rotating the four bottom glides.

If the unit is a pedestal-desk combination, the two units should be assembled, at the desired location, per the separate instructions furnished. The height and level of both pedestal and desk should be adjusted by rotating the glides. It is important that the leveling be carefully done to avoid twisting of the enclosure when the equipment frame is rolled into the pedestal.

To facilitate handling of the heavy equipment frame and its insertion into the pedestal, it is recommended that the frame be positioned directly in front of the pedestal before mounting the heavy transformer and choke components. Two wood blocks approximately 20 inches long, 3 inches wide and 1/8 inch higher (from floor level) than the front set of rollers in the pedestal will eliminate heavy lifting. Place one block parallel to and against the front edge of the pedestal and the other block about 15 inches in front of the first block. Without moving the blocks, move the pedestal toward the wall or away from the blocks.

The amplifier frame is placed on these blocks with its rear extending 4 inches over the first block. The components that were shipped separately can now be

installed. The blocks will provide sufficient space underneath the frame to use a tool when tightening the bolts holding the components.

INSTALLATION OF COMPONENTS

Certain component parts are shipped separately either because of their weight or their fragile construction and instructions for their installation are given below. The circuit diagram and photographic illustrations will be of assistance in the placement of the parts and their leads. Unconnected or removed wires are tagged for easy identification and connection to the proper component terminal.

(1) HIGH VOLTAGE TRANSFORMER

Place the transformer on the bottom shelf at the rear right corner so the mounting holes coincide and terminals (1, 2, 3, 4) are at the rear, as shown in FIG. 3. Use four 5/16-18 screws 5/8 inch long, four flatwashers, four lockwashers and four hex nuts to fasten the transformer to the shelf. The screw head and flatwasher should be on the top and the lockwasher and nut underneath the shelf.

Connect the two 4 inch long flexible leads with tube caps to terminals 5 and 9 of the transformer secondary. The bare copper ground wire should be connected to terminal 7 on the secondary. Primary terminals 2 and 3 should be connected together with the small wire loop which has soldering lugs at each end. Connect the red plastic covered wire to the primary terminal no. 1 and the black plastic covered no. 14 wire to the no. 4 terminal.

(2) HIGH VOLTAGE CHOKE

Locate the choke on the bottom shelf at the left rear corner so the mounting holes coincide and the two terminals face to the front (FIG. 4). Use four 5/16-18 screws 1 inch long, four flatwashers, four lockwashers and four hex nuts to fasten the choke to the shelf. The screw head and flatwasher should be on the choke mounting and the lockwasher and hex nut should be underneath the shelf.

Connect the center top lead of the rectifier filament transformer to the choke terminal next to the high voltage transformer. The other choke terminal is for the two high voltage insulated leads; one from the filter capacitor and the other from the modulation transformer.

(3) MODULATION TRANSFORMER

The modulation transformer should be placed on the top shelf at the right rear corner with the two terminals at the rear as shown in FIGS. 3 and 6 with the two insulated secondary leads extending under the transformers to the rear. Bolt the transformer to the shelf using four 5/16-18 1 inch long screws, four flatwashers, four lockwashers and four hex nuts with the lockwasher and nut underneath the shelf.

Connect the two 8 inch flexible leads with tube caps to the two outside terminals, marked "P", on the transformer primary. The two primary terminals, with "B" designations, connect together with the small loop of bare wire with tear drop terminals (packaged separately) and the high voltage lead from the shorting relay connects to either of these "B" terminals.

On the transformer secondary, place the ball gaps (packaged separately) on the terminals first with the adjustable screw half on the "RF" designated terminal. Next connect the high voltage lead coming from the power supply to the "B" terminal and the high voltage lead going to the rf amplifier to the terminal with the "RF" designation. Finally, connect the two leads from the relay to the two secondary terminals being sure that the lead connecting the "B" secondary terminal is on the same relay terminal as the lead going to the "B" primary terminal. Keep the ball gap brackets in the vertical position and opposite each other while tightening the two terminal nuts. The ball gap should be adjusted to .050 inch separation with the feeler gauge by turning the ball gap adjusting screw.

(4) VACUUM TUBES

Place the 872A rectifier tubes in their sockets next to high voltage transformer and place the connectors on the tube caps. At the initial operation of these tubes, the filaments should be operated for 15 minutes without high voltage applied to be sure the mercury has vaporized. Place the 810 modulator tubes in the sockets next to the modulation transformer and connect the grid and plate caps.

The voltage regulator tube sockets are located on a sub-chassis just behind the power control panel (FIG. 5). The VRL05 tube goes into the middle socket and the four VRL50 tubes go into the remaining sockets.

The bias rectifier, 5V4G, socket is located on the right side of the bias-screen voltage supply when viewed from the terminal strip end (FIG. 6). The socket on the left is for the 5R4GY rectifier of the screen voltage supply.

The socket for the time delay relay, TD-300, is located on the rear of the power control panel above the overload relay and switch (FIG. 3). This thermo-operated relay will provide approximately 30 to 45 seconds delay before high voltage can be applied whenever the station is placed in operation after the filaments are off for a period of time.

Before the two 4-250A amplifier tubes are installed, the two plate terminal connectors with parasitic suppressors must be connected to the bracket at the end of the plate blocking condensers as shown in FIG. 7. Space the leads so the connector is above the center of its tube socket and tighten the hardware on the bracket as tight as possible. Place the two tubes in the sockets, tighten the plate cap screws and replace the perforated shield and all the self tapping screws. Be certain that the screws are securely tightened but avoid excess force which might strip threads.

(5) CONTROL PANEL METERS

The amplifier is normally supplied with meters at an angle for observation from a desk located to the right of the pedestal.

The meter mounting angle may be changed for observation from the other side by removing the meter shield cover and the hardware holding the meter filter board (FIG. 7). Remove meter switch ring nut so switch may be removed with the board. Move the top of the meter board out of the shield using the attached leads as a pivot and remove the lockwashers and nuts fastening the meters to the panel. The meters can now be rotated and the equipment reassembled.

R. F. AMPLIFIER

The amplifier is ready for installation in the frame after the 4-250A tubes, the plate parasitic suppressors and, if required, the position of the meters have been changed. The unit should be carefully placed into the opening of the frame so the terminal plugs engage their respective jacks in the plug-in terminal board. Align the 5 panel mounting holes with those in the frame and insert a spacer under each hole between the panel and frame. Fasten the panel to the frame using five 10-32 flat head screws which, along with the spacers, are separately packaged in a container marked "PANEL MOUNTING HARDWARE".

PANEL FRAME

After the panel is securely in place, the panel frame may be installed with the door catch on the right side when viewed from the front of the pedestal. Position the frame against the front panel of the pedestal. Fasten the panel frame to the angle iron frame using the 4 clips and 4 self tapping screws which are in a package with the "PANEL MOUNTING HARDWARE" identification. The clip hooks are fastened as shown below:

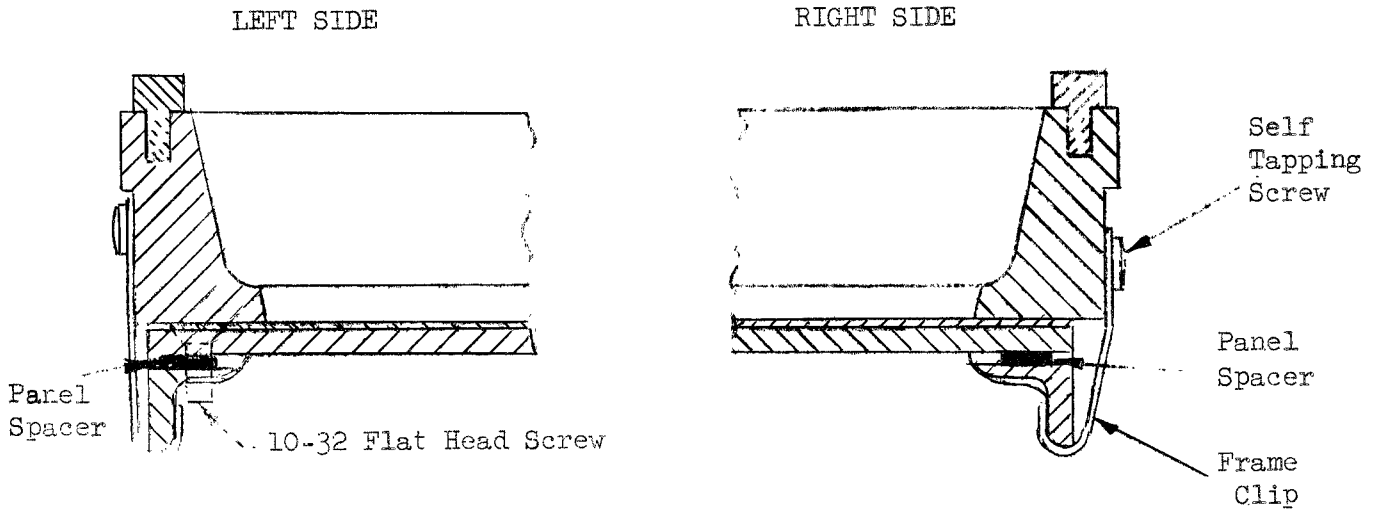

PANEL FRAME MOUNTING

TOP PANEL COVER

This cover is located at the front right side of the pedestal. When it is in the nested position, a slight downward pressure on the edge will release the cover, which is spring loaded, and it will move upward in position for handling. The cover can be lifted out and placed over the panel. To reinsert the cover, slide it into the guides and, when it is about fully inserted, push the small button on the frame toward the cover. Continue to slide the cover until its top is level with the frame top and the button has engaged the lock slot in the cover thus holding it in the down position. The cover should always be removed from the nest when the equipment frame is being moved into or out of the pedestal.

FRONT PANEL COVER

The front panel sliding door is installed behind the pedestal front panel when the unit is shipped. It may be operated by catching the bottom edge and moving it up or down in its guide grooves. Retaining catches are provided to hold the door in place when it is in the up position.

MODIFICATION, 230 TO 115 VOLT POWER

The amplifier is normally wired for a 230 volt, 3 wire, 50/60 cycle, grounded neutral, single phase power source as shown in the schematic diagram. The amplifier may be operated on 115 volt, 2 wire, 50/60 cycle, single phase power source by changing the connections of voltage change relay (RY303) as shown below. The 230 volt input is recommended as it will give the best input regulation.

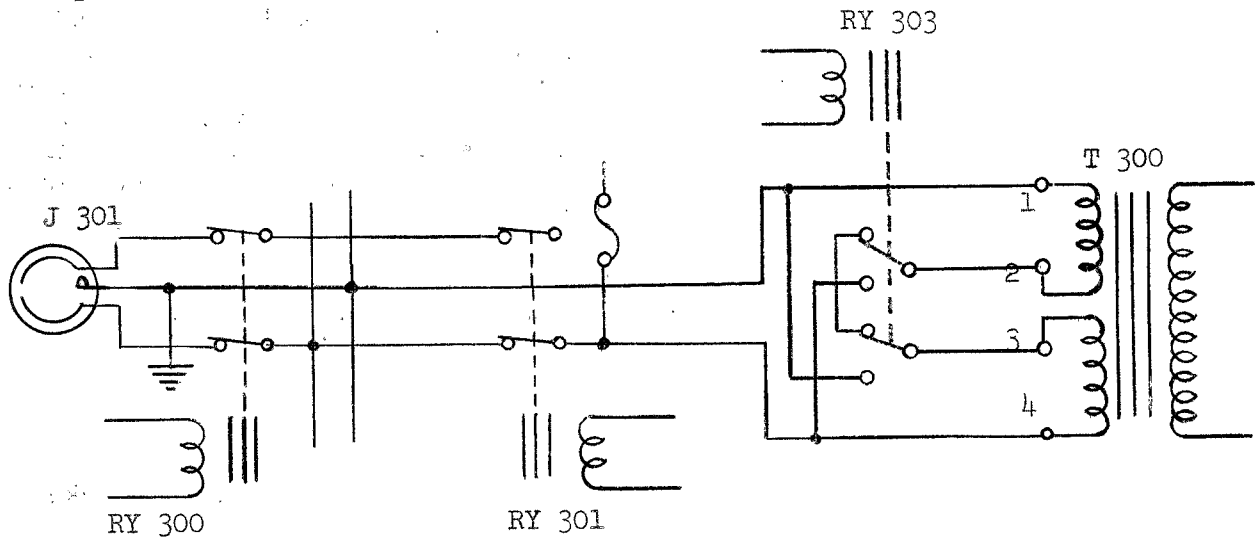

POWER INPUT MODIFICATION FOR 115 VOLTS
(RY 303 SHOWN IN LOW POWER POSITION)

MAIN POWER LINE AND FUSES

The wire connecting the power service entrance and the three wire plug should be at least No. 10 for 230 volts and No. 8 for 115 volts. For 230 volt input, the neutral should connect to the key terminal on the plug so that it contacts the white covered wire contact in the socket as shown in the schematic diagram. If 115 volts input is used, the two lines should be connected in the plug to contact the white and black wire contacts in the socket. Be sure the key lock is removed from the filament switch (S301) before connecting the power to the unit.

Each side of neutral of the 230 volt power line must be fused with 20 ampere fuses preferably at the power service entrance. If 115 volt primary power is used, 30 ampere fuses must be used in this circuit. This size fuse is sufficient to operate the amplifier at 1000 watts input and any abnormal loss of line fuses is a good indication that the amplifier is not operating properly and the trouble should be investigated.

EXCITER CABLES

Before any cables and connections are made between the exciter and amplifier, some consideration should be given as to the most desirable location of the exciter

and any future move that may be contemplated. The length of the cables, especially the coaxial cable, should be made as short as possible.

(1) POWER CABLE

The socket for the 115 volt exciter power plug is located on the rear power panel as shown in FIG. 6. There are no fuses in the amplifier unit for this power connection so the exciter should contain its own. If the exciter switch fails to control the plate voltage relay (RY301), it will be necessary to reverse the exciter power plug in its socket so the switch is on the proper side of the power line.

(2) AUDIO AND CONTROL CABLE

The number 3 and 5 pins of the octal plug should be connected to the secondary terminals of the audio driver output transformer using individually shielded wires. The same type of wire should be used to connect the modulator bias pin, No. 4, to the secondary center tap of the output transformer. The wire shields should be bonded together and connected to the No. 1 pin and the other end to the exciter chassis thus providing a common ground between units.

The lead from the exciter switch to the No. 8 pin of the plug should be at least No. 18 or equivalent in flexible stranded wire. If the Ranger is used as an exciter, this lead should go to the top pin of the antenna relay plug.

Ranger Socket
X13A

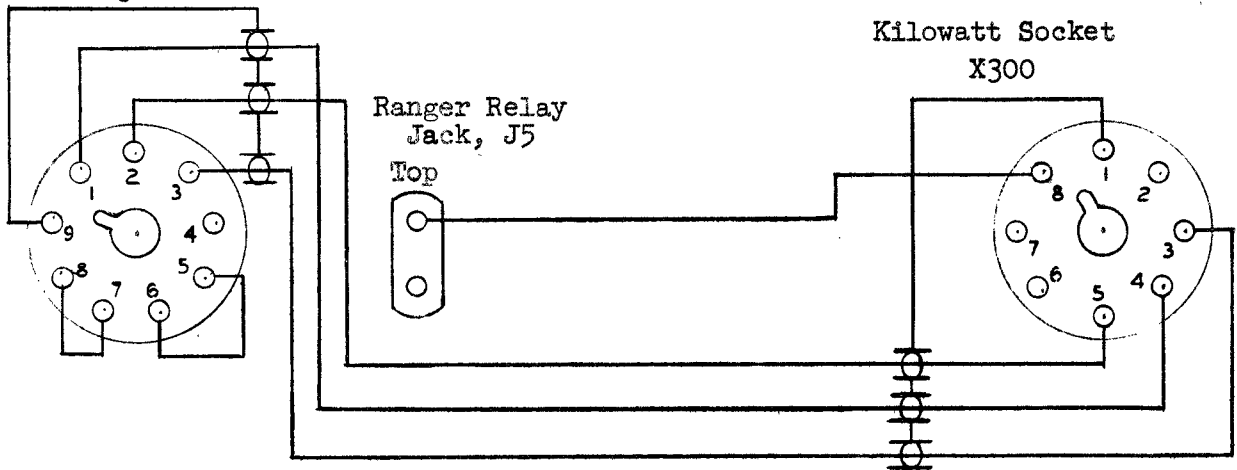

(3) EXCITER COAXIAL CABLE

The coaxial cable connecting the exciter output to the amplifier grid should have a 52 ohm impedance with an appropriate connector at each end. The amplifier unit has an 83-1R coaxial grid input receptacle which will require an 81-1SP cable plug. The length of the cable should reach from the exciter to the rear of the pedestal unit plus 48 inches to reach the terminal inside the unit. This will allow enough slack to partly slide the unit out of the pedestal without disconnecting the cable. The exciter cable entrance is in the lower left hand corner in the rear of the pedestal next to the power input panel, and is run under the side braces and up to the amplifier unit.

AMPLIFIER OUTPUT COAXIAL CABLE

The amplifier is designed to be used with a 52 ohm impedance coaxial line which should be fitted with an 81-1SP cable plug. Approximately 48 inches length should be added to the coaxial line to allow connection inside the pedestal when the amplifier unit is partly withdrawn. The output cable enters the pedestal at the rear lower right corner and is run under the side braces and up to the amplifier unit just behind the power control panel. Like the grid input termination, the output connection is available with the amplifier unit withdrawn about 1/4 of its length.

GROUND CONNECTION

A heavy soldering lug is located on one of the wing screws, which hold the frame to the pedestal, to provide a termination for the ground wire. This lead should be of No. 12 or larger copper wire and securely connected to a good ground. If the amplifier is rather remote from the ground level, a good ground may be secured on cold water pipes. However, if the lead to ground level is comparatively short, a couple of copper plated ground rods driven into the ground a number of feet will provide a good ground. In any situation, ground lead lengths of odd quarter wavelengths of the operating frequency must be avoided in securing a low impedance ground termination at the amplifier.

INSTALLATION OF AMPLIFIER INTO CABINET

When the components have been installed, the pedestal may be moved up to the first block and the frame should extend approximately 4 inches inside the pedestal. Raise up slightly on the front end of the frame to engage the rollers, remove the two blocks, lower the frame back to level, and slide the frame into the pedestal until it is against the back. Save the blocks of wood as they can be used whenever the frame is withdrawn more than 1/3 its length from the pedestal. The two wing screws fasten the frame to the rear of the pedestal. Do not forget to couple the input and output coaxial cables when the frame is approximately 3/4 engaged into the pedestal, prior to pushing the frame against the back of the pedestal.

C A U T I O N

Operation of this equipment involves high voltages which are dangerous to life and the operator should observe proper safety precautions at all times. Do not make adjustments inside the amplifier with the power supplies operating or short out the interlock switch. Make a habit of using a grounding hook with an insulated handle which can be placed on the high voltage terminal of the filter condenser whenever working inside the amplifier.

CIRCUITRY

The following description of controls, currents and voltages is given to familiarize the operator with the functions and operation of the amplifier. Frequent references to the photographs and schematic diagram will clarify the circuit and control locations.

1. LINE POWER CONTROL

The filament switch, S301, controls the relay, RY300, which applies power to the exciter and the amplifier filaments and bias.

2. PLATE -SCREEN VOLTAGE CONTROL

A series circuit of the exciter switch, interlock switch (S300), thermo-delay (TD300), contacts of overload relay (RY302) and plate power switch (S104) control the plate voltage relay (RY301).

3. PLATE VOLTAGE CHANGE

Selection made by the mode of operation switch, S200, and relay, RY303.

4. OVERLOAD CONTROL

Performed by the relay, RY302, operating in the 4-250A cathode circuit and adjusted by the resistor, R300. Reset of the overload relay is performed by the switch, S302.

5. MODULATOR SHORTING

Modulator grids and output are shorted by the relay, RY304, on TUNE, CW-HI and SSB when selected by the mode of operation switch, S200.

6. MODE OF OPERATION SWITCH

The switch, S200, selects the proper bias, screen and plate voltages for each mode as well as opens the modulator shorting relay during AM operation.

7. MODULATOR BIAS

Selected by mode of operation switch (S200) from the bias voltage divider. The bias value for AM-LO and CW-LO is fixed while the bias for AM-HI, CW-HI and SSB is adjusted by the resistor, R205, as given in TABLE C.

8. MODULATOR CURRENT

The modulator is biased for class B operation in AM operation and will draw a static plate current on CW and SSB operation to assist voltage regulation as shown in TABLE C. The modulator current peaks at 100% modulation using speech input is 90 to 100 ma. for AM-LO and 175-200 ma. for AM-HI operation.

9. AMPLIFIER BIAS

Bias is selected by the mode switch, S200, from the bias voltage divider and the series resistors, R208-R110. Fixed bias for CW-HI is adjusted

by the resistor, R206, while that for SSB operation is adjusted by the resistor, R202. Fixed and total bias voltage values are given in TABLE C.

10. AMPLIFIER PLATE CURRENT

The meter (M101) mounted on the control panel, reads total cathode current which is the sum of the plate current, screen current and the grid current of the 4-250A tubes. The final amplifier should be loaded until this meter reads the "Icath" current for the various modes of operation as listed in Table C. This "Icath" current loading of the amplifier permits the tubes to draw an actual plate current of the values listed for "Iplate" in Table C for the different modes of operation.

As an example, the AM-HI operation lists the proper "Icath" current for 1000 watts input as 495 ma. This results in 400 ma of plate current (Ip) which with 2500 volts plate voltage gives an input of 1000 watts to the amplifier.

The fixed bias is such as to allow a static plate current (below rated plate dissipation) with no excitation to improve voltage regulation. The additional bias developed across the grid resistor by grid drive results in a total bias as required for the specific mode of operation.

11. AMPLIFIER SCREEN VOLTAGE

The mode switch, S200, selects the screen supply primary tap and the various screen voltages determined by the resistors, R209 thru R213. Screen voltage regulation for AM and SSB operation is performed by regulator tubes (V202 thru V206). A choke, L202, is used to swing the screen voltage during AM modulation. Typical values of screen voltage for each mode of operation are given in TABLE C.

12. AMPLIFIER GRID CURRENT

Grid current is read by the grid-modulator current meter, M100, as selected by the meter switch, S103. The recommended grid current is 20 ma. in all modes of operation, except SSB, and this value of current should not be exceeded. In SSB operation, full peak power output will be realized without drawing grid current when a sine wave audio signal is used, and with 1 to 2 ma. peak grid current on voice operation.

13. AMPLIFIER PLATE VOLTAGE

The high and low voltage is selected by the mode switch, S200, and the relay, RY303. The plate voltage values for full load and standby conditions are given in TABLE C and are read on the PLATE VOLTMETER, M300.

14. AMPLIFIER GRID CIRCUIT

Link coupling is used to couple the exciter power into the grid circuit network consisting of two inductors, L100, L101, and a variable capacitor, C101. The links and inductors are changed by the switch, S100, for continuous coverage from 3.5 to 30 megacycles. The grids are loaded with the resistors, R101-R102, for more stable operation and have a choke-resistor, L104-R105, filter for parasitic suppression.

15. AMPLIFIER SCREEN CIRCUIT

The two screen terminals of each 4-250A are connected with a wide copper strap and are by-passed to ground at the strap center through a choke-resistor (L105-R106 and L106-R107) parasitic suppressor. No metering of the screen current is provided since this current will be of the proper value for the plate loading indicated for each type of operation.

16. AMPLIFIER PLATE CIRCUIT

Two parallel 4-250A tubes, shunt fed, are used in a conventional PI output network consisting of an inductor, L108, and the capacitors, C119 thru C122. The variable inductor and the capacitor, C119, are gear driven from a single dial and knob for continuous coverage from 3.5 to 30 megacycles. The plate tuning switch, S102, is used to open the capacitor for operation above 13 megacycles using only the inductor and circuit capacities. Load coupling is accomplished by selection of capacities by a shorting switch, S101, and adjusting the dual variable capacitor, C122, for proper amplifier current.

Protection of the high voltage circuit is provided by the ball gap, G100, which is adjusted for a spacing of .054 inches. If the gap arcs over, it is an indication that high transient voltages are being developed which are usually caused by opening the antenna relay at the same instant the primary power is removed from the high voltage transformer. This is discussed further on Page 23 in the section of FAST MAKE - SLOW BREAK ANTENNA RELAY SYSTEM. The chokes, L110, L111, provide protection in case of breakdown of the plate blocking capacitors, C116, C117, which would place the plate voltage on the antenna system.

17. NO EXCITATION CONDITION VOLTAGES AND CURRENTS

Table C lists the average voltages and currents that may be experienced when the amplifier is in a no RF excitation condition. This condition is secured by allowing the high voltage to stay on, but removing the RF excitation to the grids of the 4-250A tubes (note I_g reads zero in the chart). The fixed bias is such as to allow the 4-250A tubes and the 810 modulators to draw some current to improve voltage regulation. On AM operation, the audio drive must be removed with the RF excitation otherwise the modulation transformer safety gap will flash over. If the Ranger transmitter is used as an exciter the No Excitation Condition voltages and currents can be obtained by switching the Ranger OPERATE switch to the CW position with the key open. The RF excitation to the final amplifier is thereby removed along with the audio drive thus placing the power amplifier in the above condition and allowing these voltages and currents to be read.

18. R. F. FILTERING AND SHIELDING

Dual section filters are provided in each of the leads leaving the shielded rf amplifier via the plug-in the TERMINAL BOARD, TB100. Each lead to the shielded meters is also filtered with dual section filters in addition to a filter between the grid resistor, R110, and the choke, L112. Engineering laboratory measurements indicate a very low level of harmonic radiation from the unit because of these precautions. However, TVI may be experienced if the shielding is not completely "buttoned up" by leaving out some of the shielding screws.

ADJUSTMENT

EXCITER, AM - CW

The tuning adjustments of the exciter are the same as used for normal operation except that its output may have to be reduced in order not to overdrive the Kilowatt Amplifier grid. This may be done by reducing the exciter final grid drive and/or output coupling.

When the exciter has been completely connected to the Kilowatt Amplifier, the following procedure is used for adjusting the exciter output:

- (1) Set the PLATE POWER SWITCH (S104, TUNING PANEL) in the OFF position and turn the MODE OF OPERATION SWITCH (S200, POWER CONTROL PANEL) to the TUNE position.
- (2) Place the exciter control switch in the stand-by position and the GRID-MODULATOR METER SWITCH (S103, TUNING PANEL) to read GRID current. Set the GRID TUNING dials to the positions given in TABLE A, for the band desired.
- (3) Insert the lock key into the FILAMENT SWITCH (S301, POWER CONTROL PANEL) and turn to the ON position as indicated by the filament pilot light. Power is now available at the exciter and the Kilowatt Amplifier filaments and bias supply but not to the screen or plate voltage supplies.
- (4) Adjust the exciter drive and/or output for a maximum amplifier grid current of 20 ma. with the amplifier grid inductor and capacitor at the dial setting given in TABLE A. Tune the grid capacitor for maximum grid current, reducing the grid drive if necessary to avoid exceeding 20 ma. grid current.

If a Viking Ranger is used as an exciter, the approximate dial settings for coupling and final tuning are given in TABLE B. At other frequencies, adjust the Ranger drive and/or output for 2 or 3 ma. final grid current and tune the GRID CAPACITOR (C101, TUNING PANEL) for a peak grid current. This grid tuning position will be with the least reflected impedance and should be recorded for future use. The Ranger output may now be increased until a maximum of 20 ma. grid current is indicated on the amplifier meter. It is convenient to have the exciter grid drive a little below normal so only this control may be adjusted for 20 ma. grid current on other modes of operation. Resonate exciter final after each grid circuit adjustment.

When a transmitter of 100 watts or more power output is used as an exciter, the output usually cannot be reduced much below 50 watts without encountering difficulties if the reduction is made only by reducing the load coupling. The output can be further reduced by reduction of plate and/or screen voltages and grid drive to the exciter output amplifier. Another method, entailing no modification of the exciter, is to insert a non-inductive resistor load at the exciter output to absorb the difference between the minimum output and the 30 watts required to drive the Kilowatt Amplifier. This latter method also has the advantage of providing a well regulated driving source. The resistor or parallel resistors should have a resistance of 100 ohms and a total continuous rating of at least 20 watts.

The JOHNSON NON-INDUCTIVE POWER REDUCER LOAD, part No. 250-29 is available

in a TVI shielded enclosure with a rating of 25 watts at 100 ohms resistance. Type 83-1R coaxial receptacles are provided at each end of the enclosure for insertion into the exciter to amplifier coaxial cable.

KILOWATT AMPLIFIER, AM - CW

After the grid drive has been set at the proper value, the amplifier tank and output circuits may be adjusted as follows:

- (1) Set the PLATE TUNING DIAL and SWITCH (S102) as well as the COUPLING DIALS (C122-S101), all located on the tuning panel, to the positions given in TABLE A.
- (2) Place the PLATE POWER SWITCH (S104) in the ON position and rotate the tuning dial knob for minimum plate current. The grid current will drop off slightly but the lower value will be permissible while the plate circuit is being adjusted to resonance.
- (3) Once the minimum plate current adjustment has been made, the exciter output should be increased to give 20 ma. grid current. The COUPLING capacitor is adjusted to increase or decrease the value of minimum plate current keeping in mind that the PLATE TUNING must be readjusted for each change of COUPLING tuning. The PLATE CURRENT METER reads the cathode current and the minimum current reading should be that given in TABLE C.
- (4) The amplifier is designed to operate either with a FULL kilowatt input on AM-HI and CW-HI or with a 300 watt input on TUNE and AM-LO positions. Any deviation from these loads, especially on AM-HI, will result in the following:
 - (a) Screen current will increase with reduced loading of the amplifier on either AM or CW positions and damage may occur to the screen power supply if operated continuously under this condition.
 - (b) Reduced loading of the amplifier will result in a mis-match of the modulation transformer and excessive audio voltages will be imposed on the dc voltages at normal modulator plate current peaks. This condition becomes progressively worse as the loading of the final is reduced causing arc-overs of the G-100 Ball Gap, damage to by-pass capacitors, flash-overs inside the RF Unit, flash-overs and insulation breakdown of the tank switch S-102, and blowing of the main power line fuses.
- (5) The amplifier may now be changed to another type of operation as selected by the MODE OF OPERATION SWITCH (S200, POWER CONTROL PANEL). CAUTION MUST BE OBSERVED that the exciter and amplifier are in the standby position before moving the MODE OF OPERATION SWITCH. The exciter switch should be used to turn off the exciter and the Kilowatt Amplifier screen and plate voltages for this change.

Changing from one type of operation to another will require only a slight adjustment of driving power at the exciter except in SSB operation which will be discussed elsewhere in the instructions. In all types of operation, the grid, plate and loading dial settings should be approximately the same as that secured in the TUNE position. Proper bias, screen, and plate voltages are selected as the MODE OF OPERATION SWITCH is changed.

AM MODULATOR

The carrier can be 100% amplitude modulated when the MODE OF OPERATION SWITCH is in either the AM-LO or AM-HI positions. With speech input into the audio driver, the modulator current at 100% modulation should not exceed peak values of 90 to 100 ma in AM-LO operation and 175 to 200 ma in AM-HI operation. This value of peak current will vary with the voice characteristics of the operator and the response of the speech amplifier.

The meter which reads this current (M100) is the combination grid-modulator current meter switched by S103 to the modulator current position. It reads directly the modulator plate current, $I_p(\text{mod})$, as listed in Table C. Any peak current over the values given above and in Table C for $I_p(\text{mod})$ for AM-LO and AM-HI operation will result in overmodulation. During CW, SSB and No Excitation operation the modulators are allowed to draw some static current to improve the voltage regulation. Excessive modulator static current, with the proper plate voltage, indicates low bias or loss of bias on the modulator grids, or possible feed-back in the audio system. The connecting plug from the audio driver must be inserted into socket X300 to complete the bias circuit to the modulator grids.

SSB OPERATION

The amplifier may be adjusted for SSB operation by tuning it as described in the preceding instructions and properly loading the final in the AM-HI position. The MODE OF OPERATION SWITCH (S200) should then be changed to SSB position and a SSB signal fed into the amplifier grid. The proper bias and screen voltages, as listed in TABLE C, are selected by the MODE OF OPERATION SWITCH. The tuning adjustments should remain the same since the tube plate impedance is approximately the same value for both modes of operation. With voice or a single tone input, gradually advance the audio gain and peak the grid circuit of the amplifier for a slight upward kick in plate current. After the grid circuit is peaked, the gain may be advanced to a maximum plate current swing of 415 ma. which provides the maximum power permitted an amateur in SSB operation. During voice operation approximately 1 to 2 ma. peak grid current may be indicated when swinging the cathode current to 415 ma. peak.

In voice-controlled SSB operation, the amplifier may be left in the ON position during both receive and transmit periods since the amplifier will cause no noise in the receiver. However, the exciter must not contribute appreciable noise or it will be necessary to apply blocking or "quieting" bias to the exciter.

A SSB exciter capable of CW, AM and SSB operation may be used as the only exciter with the Kilowatt Amplifier if its power output is 30 watts on AM or CW and 2-3 watts peak power on SSB. With carrier inserted in the exciter, the tuning procedure is the same as described in the preceding paragraph. In this case, carrier is inserted and the amplifier loaded in the AM-HI position prior to switching to SSB in both the exciter and amplifier.

The Kilowatt Amplifier may be adjusted for SSB using only a SSB exciter with the MODE OF OPERATION SWITCH in the SSB position. With a small amount of single tone, carrier inserted, SSB signal to the grid input and plate voltage on the final, peak the grid tuning until the plate current begins to rise from its static value. Adjust the final tuning for minimum plate current, peak the grid circuit, and then increase the grid drive until the amplifier plate current is 415 ma. maximum. If the load is proper, the 415 ma. plate current will be reached just before there is an indication of grid current on the grid meter. If grid current is indicated before the specified plate current of 415 ma. is obtained, the loading is too light

and the coupling should be increased. When the loading is too light, the amplifier is driven into saturation sooner than with proper loading and the output is considerably reduced. If the coupling is too heavy, the stage will not saturate easily but the output will be below that of proper coupling. Excess coupling should be avoided by approaching from the lightly loaded direction. After each adjustment of the coupling control, the plate tuning should be readjusted for minimum plate current.

If a check of the linearity of the amplifier is desired, it may be performed in the following manner:

- (1) Inject carrier and feed a single sine wave tone into the microphone input of the SSB exciter. If a phasing exciter is used, feed one sine wave tone into the microphone input and place the exciter function switch in the AM position. The carrier and audio input must be of equal magnitude. The output will be a single sideband two-tone wave. Adjust the final amplifier as described in the preceding instructions.
- (2) Couple an oscilloscope into the output of the amplifier and observe the pattern. If the amplifier is operating properly, the envelopes on each side of the center line should be perfect sine waves with rounded top portions and the sides forming an X at the cross-over. If the tops of the envelopes become flat (when the SSB drive is increased) at a plate current below normal, the amplifier is too lightly loaded or the exciter is overloaded. This can be checked further by tuning the final slightly off resonance and, if the flats become round again, the amplifier is not loaded enough. When the flats still remain, the exciter and/or the coupling between exciter and amplifier should be made more efficient. A wide cross over at the center line of the oscilloscope pattern is an indication the amplifier bias is too high and should be reduced.

GENERAL OPERATION

After the amplifier has been adjusted at the desired frequencies and the dial settings recorded, the amplifier is ready for operation. In any of the modes of operation, the amplifier normally should be controlled along with the exciter by means of the exciter switch. However, when shifting frequency or zero beating, the PLATE POWER SWITCH (S104) is used to remove the amplifier screen and plate voltages allowing only the exciter to operate. If the exciter has a "zeroing" provision which does not actuate the Kilowatt plate contactor, the switch may be left in the ON position.

Band changing is accomplished by setting the exciter and amplifier dials and switches to the recorded positions for the desired frequency, and trimming the grid and plate currents after the PLATE POWER SWITCH is in the ON position. It is assumed that the amplifier load or antenna is the same as used when the dial settings were recorded.

BIAS, OVERLOAD AND NEUTRALIZATION

The Kilowatt Amplifier bias, overload relay, and neutralization have been adjusted at the factory. However, if there is any evidence that these controls have been moved, they may be readjusted as described in the following paragraphs:

(1) RF AMPLIFIER BIAS

All bias values are fixed except for the CW-HI and SSB modes of operation. The CW-HI bias is adjusted by potentiometer (R206, RESISTOR BOARD), with no grid drive, to give the standby plate current as given in TABLE C.

The SSB bias is adjusted by potentiometer (R202, RESISTOR BOARD) to a value (approximately - 100 volts) which gives 150 ma. standby plate current with no SSB signal at the amplifier grid.

(2) MODULATOR BIAS

The AM-HI modulator bias is adjusted by potentiometer (R205, RESISTOR BOARD) to 45 ma static modulator plate current (no audio signal) which is also the bias used in CW-HI and SSB operation. The AM-LO and TUNE position biases are fixed values.

(3) OVERLOAD RELAY

The normal operating position of the overload relay is 600 to 650 ma. current as indicated on the PLATE CURRENT METER. This operating current may be increased by turning potentiometer (R300, RESISTOR BOARD) in the clockwise direction, or decreased by counterclockwise rotation. Resetting of the overload relay is accomplished by momentarily depressing the OVERLOAD SWITCH (S302, POWER CONTROL PANEL).

(4) NEUTRALIZATION

The neutralization may be checked by moving the PLATE TUNING knob through the resonance point with full loading and observing the behavior of the grid meter. At proper neutralization, the grid current should fall off on both sides of resonance although a steady or slight rising current on the low frequency side is satisfactory. If the neutralization should require adjustment, it may be accomplished by turning the neutralizing condenser (C102) shaft with a tuning rod of insulation material. Neutralization should be adjusted on the 20 meter band. The panel hole for this adjustment is under the TUNING DIAL cover at the rear left corner. CAUTION: DO NOT ATTEMPT TO ADJUST THE NEUTRALIZATION WITH HIGH VOLTAGE ON.

KILOWATT AMPLIFIER AT 25 MC

If contemplated operation is in the vicinity of 25 megacycles, the RF choke (L101) shunt feeding the amplifier will have to be changed. The choke becomes series resonant near this frequency and can be modified by removal of a few of its top turns of wire. Measurements can be made with a grid-dip meter after removing the top connection of the choke from the amplifier and shorting the choke with a heavy wire.

AUDIO DRIVER

The audio driver should be capable of providing the required peak audio-frequency grid-to-grid voltage of the 810 tubes in the class B modulator. Since the grids of the modulators represent a variable load resistance, the driver stage must have good regulation. Improved regulation of the driver may be accomplished by placing a resistor across each half of the driver transformer secondary.

The following list of transmitters used as exciters and their respective output loading resistors may be used as indicative of the resistor values required. In the case of the 32V series transmitters, a 500 ohm line to push-pull grids transformer is required. In this case, the transformer and resistors may be mounted on the rear of the cabinet or on a small separate chassis. In all installations, leads leaving the excitor should be well filtered to avoid TVI trouble.

Johnson Viking I -- 1000 ohm, 20 watt resistor each side of output transformer C.T.

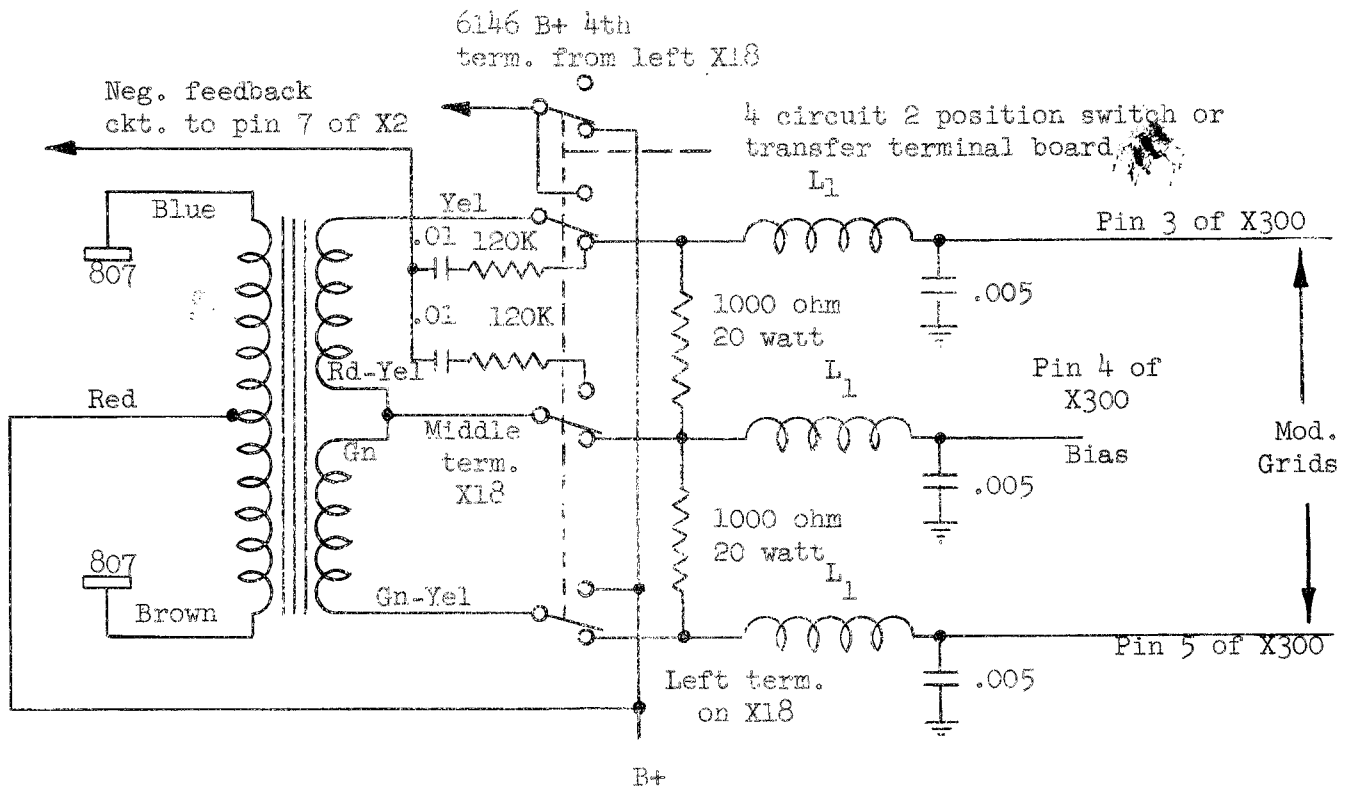

$L_1 = 4 - 10$ microhenry choke

Collins 32V -- 500 ohm line to 3300 ohm C.T. grid to grid transformer, such as:

Stancor part no. A-3802
 Thordarson part no. 22S78
 S N C part no 6P726

1500 ohm, 20 watt resistor each side of output transformer C.T.

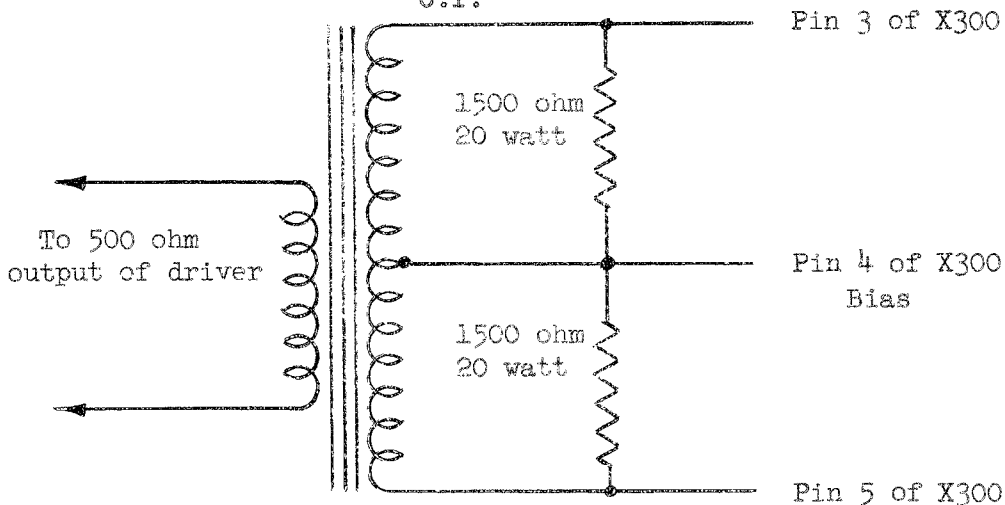

Johnson Viking II -- 1000 watt resistor, each side of output transformer C.T.

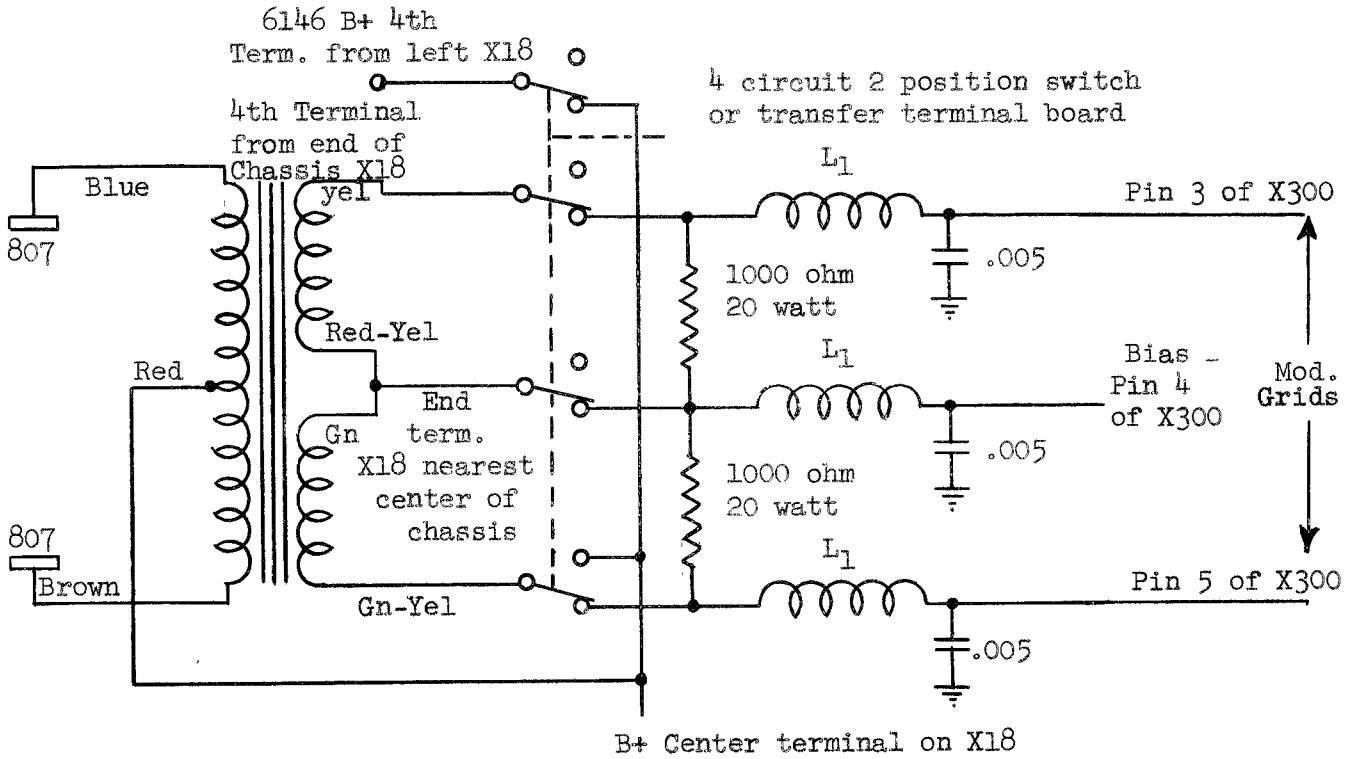

$L_1 = 4 - 10$ microhenry choke

TVI AND ANTENNA COUPLING CONSIDERATIONS

1. TELEVISION INTERFERENCE

In general, the problem of TV interference varies with the individual locations and might, in some instances, require additional filtering be added to the transmitter and/or receiver. The Kilowatt Amplifier unit has sufficient shielding and filtering to operate without TVI in normal signal areas.

When the amplifier is operated in "fringe" areas, a low pass filter (JOHNSON 250-20) in the output may be required to reduce the harmonic level substantially below that of the TV signal. Further harmonic reduction, such as offered by the JOHNSON Kilowatt Matchbox, may be required in the extreme fringe area.

Where the TV receiver and transmitter are in close proximity, the receiver may require the addition of a high pass filter at the antenna terminals and, in some cases, a power line filter installed at the chassis. Some receivers, not having adequate shielding, may also require some additional shielding. Instances of detection in the 2nd audio stage may be solved by the usual by-passing methods. As in the case of the transmitter, the filtering problem at the receiver becomes more acute in the weaker fringe areas.

Information on receiver TVI elimination is contained in various amateur and commercial publications.

(1) EXCITER

The exciter should not cause any TVI when operated on the different bands as the overall suppression will be no better than that of the exciter itself. If any leads are added to an existing TVI suppressed exciter, they must be thoroughly filtered.

(2) KILOWATT AMPLIFIER

The Kilowatt Amplifier rf unit is enclosed in a completely shielded enclosure with each meter and power lead containing a dual section filter. The meters are contained in their own shield compartment and each control shaft is grounded to suppress radiation. Laboratory measurements have substantiated that the level of harmonic radiation from the shielded enclosure is well below the minimum requirements.

The amplifier has been subjected to rigorous tests for parasitic oscillations and suppressors have been placed in the grid, screen and plate circuits to eliminate such oscillations.

(3) LOW-PASS OUTPUT FILTER

In areas where TVI is a problem, a well designed multi-section low pass filter, such as the JOHNSON 250-20, should be installed in the output coaxial line of the amplifier. The filter should be mounted on the back of the pedestal and securely bonded to it. The lead from the low pass filter into the amplifier should be long enough to allow the amplifier frame to be partially withdrawn from the pedestal. The SWR on the coaxial transmission line should be 2 or less when a low pass filter is used.

2. ANTENNA COUPLING UNIT

When the Kilowatt Amplifier is used with open wire transmission lines or direct end fed antennas, some system of coupling the high impedance line must be used. A coupler must also be used to transfer the higher line impedance to the lower impedance (usually 52 ohms) of a low pass filter.

For ease of operation, the coupler should provide panel bandswitching and tuning as well as transferring the antenna system from transmitter to receiver. A well designed and shielded coupler will also provide a substantial reduction in harmonic and spurious radiation from the transmission line and antenna and may be needed in extreme TV fringe areas.

The JOHNSON Kilowatt Matchbox fulfills the above requirements for an antenna coupler.

3. FAST MAKE - SLOW BREAK ANTENNA RELAY SYSTEM

In any high power phone operation, serious consideration should be given the very high transient voltages that can be developed in the final amplifier when the antenna load and primary power of the high voltage supply are opened at the same time. This high voltage can be further increased by modulation peaks and primary power cycle peaks at the time of switching. The voltages developed are very destructive to the antenna relay contacts and, in some instances, to high voltage by-pass condensers.

The above condition may be corrected by the use of a "fast make - slow break" antenna change-over relay system as shown in the circuit diagram.

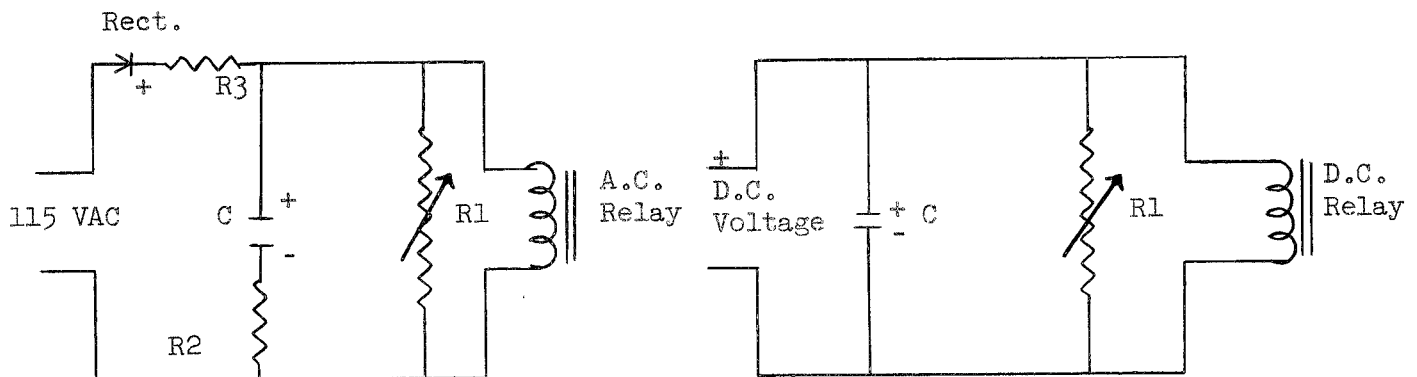

C = 60 mfd electrolytic condenser
R1 = 0.25 megohm potentiometer
R2 = 22 ohm 2 watt resistor
R3 = Voltage limiting resistor
Rect = Selenium rectifier

The correct values of C and R1 may be determined by a little experimenting and should give a time delay between 0.1 and 0.25 seconds which will be satisfactory for most installations. This time delay is secured by adjusting R1 and/or C until the arcing at the antenna relay contacts disappears on the break operation. Resistor R2 is a current limiting resistor and the

selenium rectifier should have a continuous current rating equal to the total current drawn by the resistor R1 and the relay coil.

When an ac relay is used in this system, the dc resistance of the coil is much less than the ac impedance and a resistor must be placed in series with the ac power lines. This resistor (R3 in diagram above) should reduce the dc voltage to the relay coil until there is no appreciable heating, but not low enough to materially effect the "fast-make-slow-break" action. The higher the dc resistance of the relay coil, the less capacity will be needed in the electrolytic capacitor (C above) for the same time delay.

If the pole of the A.C. type relay has a tendency to become magnetized when direct current is used, a small piece of thin paper glued to the top of the pole piece will prevent the armature from remaining in the ON position when current is removed.

MAINTENANCE

1. ROUTINE

Periodic inspection of both mechanical and electrical parts is one of the best assurances of continued trouble free operation. Excessive humidity, dirt and corrosion are the causes of most electronic equipment failure in a properly operating unit. A soft brush, a dry air jet, or a small nozzle vacuum cleaner may be used to remove dust or other foreign material.

2. SWITCHES AND RELAYS

All contacts on switches and relays should be given a periodic inspection which should include cleaning of the relay contacts with a burnishing tool (do not use sand paper or emery cloth) and wiping any dust off sliding switch contacts. Check the moving parts of relays and switches to see that they are not being hampered by accumulated dirt.

3. VENTILATION SYSTEM

All fans should be given a sparse oiling about every six months using a good grade of light machine oil. Do not use excessive oil which will only accumulate dust after running out of the motor. The fan blades should be adjusted, if accidentally bent, so that all blades are in line.

Both the intake and exhaust fan screens located at the rear of the pedestal should be cleaned frequently with a dry, clean cloth or a small nozzle vacuum cleaner.

4. INDICATOR LAMPS

The two indicator lamps on the operation panel can be replaced by removing the friction type jewel holder and unscrewing the bulb. The indicator light is a 6 watt 120 volt candelabra base type S6 bulb.

5. FUSES

The filament and screen voltage transformer primary fuses are located in their holders on the POWER CONTROL PANEL. These fuses are Littlefuse 3AB 5 amp. 250 volt fuses or similar types. The exciter should contain its own fuses since no fuse protection is offered at its amplifier socket. The power mains to the amplifier must also be fused on both sides of neutral as described in the DESCRIPTION SECTION of the instructions.

6. GEAR DRIVE

The bearings of gears driving the capacitor and inductor have been lubricated at the factory and no lubrication should be required for a number of years of normal usage.

7. INDUCTOR-CAPACITOR DRIVE AND STOP ASSEMBLY

In the event of any trouble with this assembly necessitating its removal from the unit, the factory should be contacted for either the detail assembly - adjustment print or other instructions.

8. PROTECTIVE BALL-GAP ADJUSTMENT

The modulation transformer secondary ball gaps, G300, must be adjusted so the .050 inch feeler gauge fits between the gap. The high voltage ball gap, G100, is adjusted at the factory for a spacing .064 inches. The spacings may be checked with an automobile type feeler gauge.

9. VACUUM TUBES

The vacuum tubes may be tested by replacing them with similiar tubes that are known to be good and observing any change in performance. Before this test is made, the amplifier should be checked for any fault that could have caused the original tube failure and would damage the new tube. In event of a failure within the tube warranty period, the tube and completed Service Report should be shipped to the appropriate manufacturer's address as given in the Standard Warranty.

10. BIAS AND SCREEN VOLTAGES

Bias and screen voltages may be measured at the various resistors attached to the resistor mounting board. This board has the schematic diagram resistor number stamped on it, on the side opposite the resistor. The voltage at the ends of each resistor is available at the mounting screw heads. Typical operating values of bias and screen voltages are given in TABLE C.

PARTS LIST

<u>Part No.</u>	<u>Item No.</u>	<u>Quantity</u>	<u>Description</u>
22.1106	V100-V101	2	Amplifier tube 4-250A
22.1107	V300-V301	2	Hi volt rectifier 872A
22.1108	V302-V303	2	Modulators 810
22.791	V200	1	Bias rectifier 5V4G
22.784	V201	1	Screen rectifier 5R4GY
22.1109	V202-V205	4	Regulator VR150
22.1110	V206	1	Regulator VR105
167-104	C101	1	75L15 variable condenser
159-375-2	C102	1	N375 variable condenser
22.1048	C103	1	1000 mmf mica condenser, 1200VW
22.828	C104-107	4	1000 mmf 1500 VW disc ceramic cond.
22.827	C108-115	8	5000 mmfd GMV 600VW disc ceramic cond.
22.1050	C116-117	2	1000 mmfd 5000VW ceramic condenser
22.1112	C118	1	500 mmfd 20 KV ceramic condenser
169-29	C119	1	190C70 variable condenser
22.1050	C120-121	2	1000 mmfd 5000VW ceramic condenser
154-513	C122	1	500ED20 variable condenser
22.827	C123-145	23	5000 mmfd GMV 600VW disc ceramic cond.
22.828	C146-147	2	1000 mmfd 1500VW disc ceramic cond.
22.1112	C148-149	2	500 mmfd 20KV ceramic condenser
22.1141	C200-201	2	8 mfd 1000 VW condenser
22.1052	C300	1	8 mfd 3000VW condenser
23.1087	L100	1	HF grid coil
23.1088	L101	1	LF grid coil
23.1083	L102-103	2	Plate parasitic choke
16.1180	L104	1	Grid parasitic choke
23.1084	L105-106	2	Screen parasitic ass'y (includes R106-R107)
236-6	L108	1	Final tuning inductor, variable
23.1085-2	L109	1	RF choke
23.1085-1	L110	1	RF choke
16.1179	L111	1	UHF choke
102-750	L112	1	RF choke
16.1181-3	L113-128	16	RF filter choke
16.1181-4	L129-135	7	RF filter choke
16.1181-3	L136-137	2	RF filter choke
22.1053	L200-202	3	12 HY 150 MA filter choke
22.1054	L300	1	6 HY 700 MA filter choke
22.803	R101-102	2	18,000 \pm 10% ohm 2 W carbon resistor
22.1030	R103-104	4	200 \pm 10% ohm 12 W resistor
22.1043	R105	4	470 \pm 10% ohm 2 W carbon resistor
22.1047	R106-107	2	100 \pm 10% ohm 2 W carbon resistor
22.864	R108	1	2.2 \pm 10% ohm 1/2 W carbon resistor
23.914-1	R109	1	.2 \pm 10% ohm wire resistor
22.1134	R110	1	2500 ohm 10 W wire resistor
22.1055	R200	1	40,000 \pm 20% ohm 20 W wire resistor
22.1033	R201	1	10,000 ohm 10 W wire resistor
22.1037	R202	1	10,000 ohm 4 W wire potentiometer
22.1034	R203	1	400 ohm 20 W wire resistor

<u>Part No.</u>	<u>Item No.</u>	<u>Quantity</u>	<u>Description</u>
22.1039	R204	1	200 ohm 10 W wire resistor
22.1036	R205-206	2	200 ohm 4 W wire potentiometer
22.1056	R207	1	250 ohm 10 W wire resistor
22.1032	R208	1	3000 ohm 10 W wire resistor
22.1035	R209	1	1000 ohm 10 W wire resistor
22.1042	R210	1	8,000 ohm 50 W wire resistor
22.1031	R211	1	1500 ohm 20 W wire resistor
22.1032	R212	1	1,500 ohm 10 W wire resistor
22.1028	R213	1	1500 ohm 50 W wire resistor, variable
22.1038	R300	1	50 ohm 4 W wire rheostat
22.1057	R301-302	2	25,000 ohm 200 W wire resistor
22.1058	R303-305	3	1 meg. \pm 1% 1.5 W resistor
22.1059	RY300-301	2	DPST N.O. 20 amp. relay 115V 60C coil
22.1061	RY302	1	SPST over load-reset relay 115V 60C coil
22.1060	RY303	1	DPDT 15 amp. relay 115V 60C coil
22.1062	RY304	1	DPST N.C. 10 amp. relay 115V 60C coil
22.1045	S100	1	Grid band switch
23.1100	S101	1	Coupling switch
23.1078	S102	1	Tuning capacitor switch
22.1064	S103	1	DPDT meter switch 3 amp. 125V AC
22.1065	S104	1	SPST control switch 3 amp. 125V AC
22.1046	S200	1	Operation mode switch 5 pos. 4 steat. wafer
22.18-1	S300	1	SPST N.O. interlock switch 12 amp. 125V AC
22.1066	S301	1	SPST lock switch 6 amp. 125V AC
22.1063	S302	1	SPST N.O. reset switch 6 amp 125V AC
22.1067	T100	1	5 volt 20 amp. filament transformer 115V PRI.
22.1068	T200	1	Bias-Filament transformer 115V PRI.
22.1069	T201	1	Screen voltage transformer 115V PRI.
22.1070	T300	1	Power transformer 115-230V PRI.
22.1071	T301	1	5 volt 20 amp. filament transformer 115V PRI.
22.1072	T302	1	Modulation transformer
22.1073	T303	1	10 volt 10 amp. filament transformer 115V PRI.
22.1074	TD300	1	40 sec time-delay SPST relay 115V heater
22.1075	B100	1	2 1/2" fan CW
22.1076	B101	1	4" fan CW
22.1077	B300	1	6" fan CW
22.1078	B301	1	6" fan CCW
22.1079		4	fan motor
22.746	J100-101	2	83-1R coax receptacle
22.1087	J300	1	115V AC exciter power receptacle
22.1083	J301	1	230V AC power receptacle
147-1002-3	I200	1	Filament indicator
147-1002-2	I201	1	Power indicator
22.21	IB200-201	2	Type S6 115V AC 6W cand. base bulb
23.1097	TB100	1	9 terminal plug-jack board
22.1088-6	TB200	1	6 position screw terminal board

<u>Part No.</u>	<u>Item No.</u>	<u>Quantity</u>	<u>Description</u>
22.1088-5	TB201	1	5 position screw terminal board
23.1075	G100	1	High Voltage ball gap
23.1074-1	G300	1	Modulation transformer ball gap
23.1074-2	G300	1	Modulation transformer ball gap
22.742	F300-301	2	5 amp. 3AG type or MTH type 250 volt fuse
22.1081	M100	1	50-500 milliammeter DC grid-modulator current
22.1080	M101	1	750 milliammeter DC final plate current
22.1082	M300	1	3000 voltmeter DC final plate voltage
22.800	PX300	1	8 pin octal plug Amphenol 86-PM8
22.1084	PJ301	1	230V AC power plug
22.1085	X300	1	8 pin octal recessed socket
122-275	XV100-101	2	4-250A tube socket
22.849-2	XV200-206	7	8 pin octal mica filled socket
123-211	XV300-303	4	4 pin jumbo socket
22.739-2	XF300-301	2	Fuse extractor post

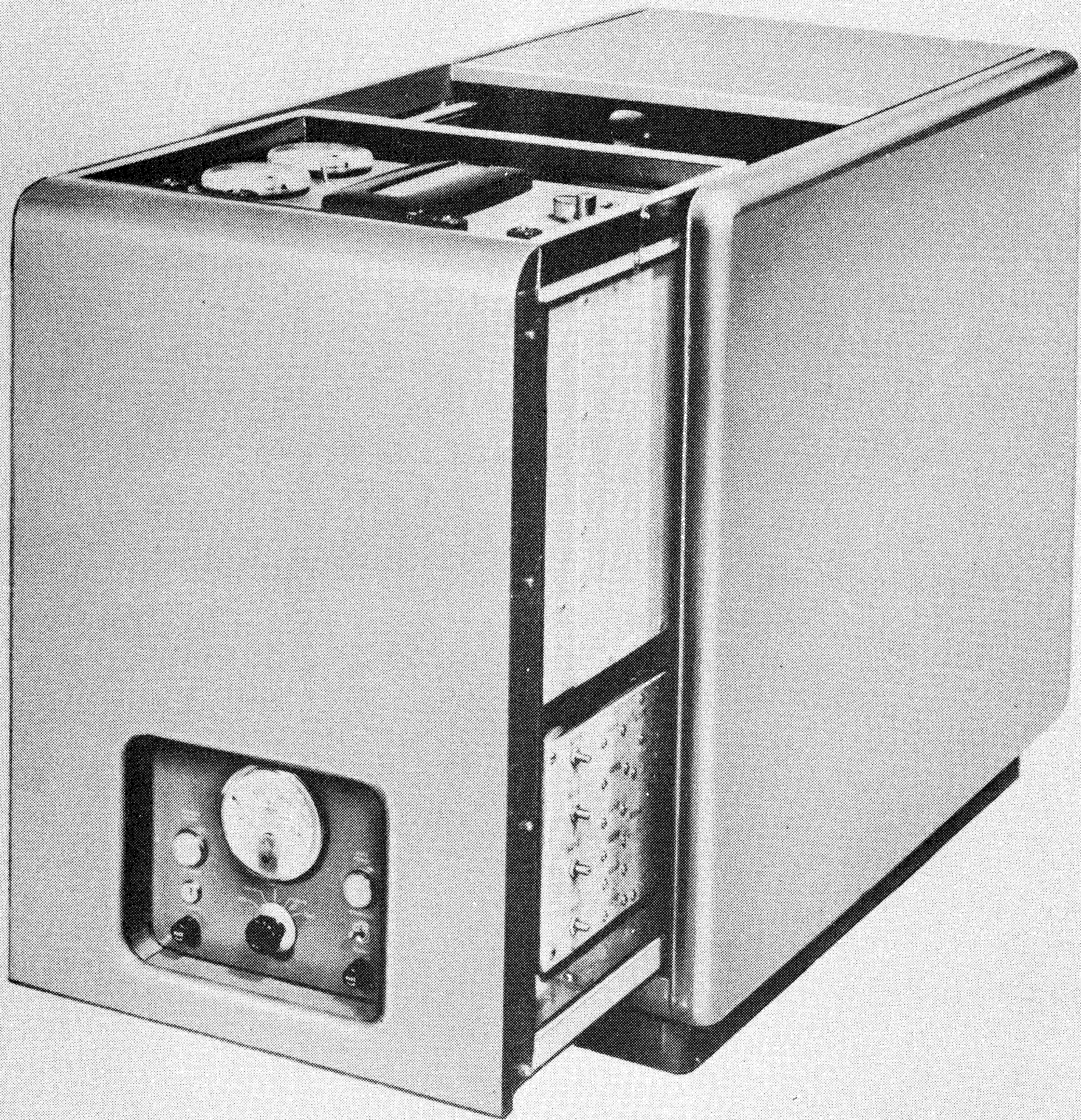

FIGURE 1

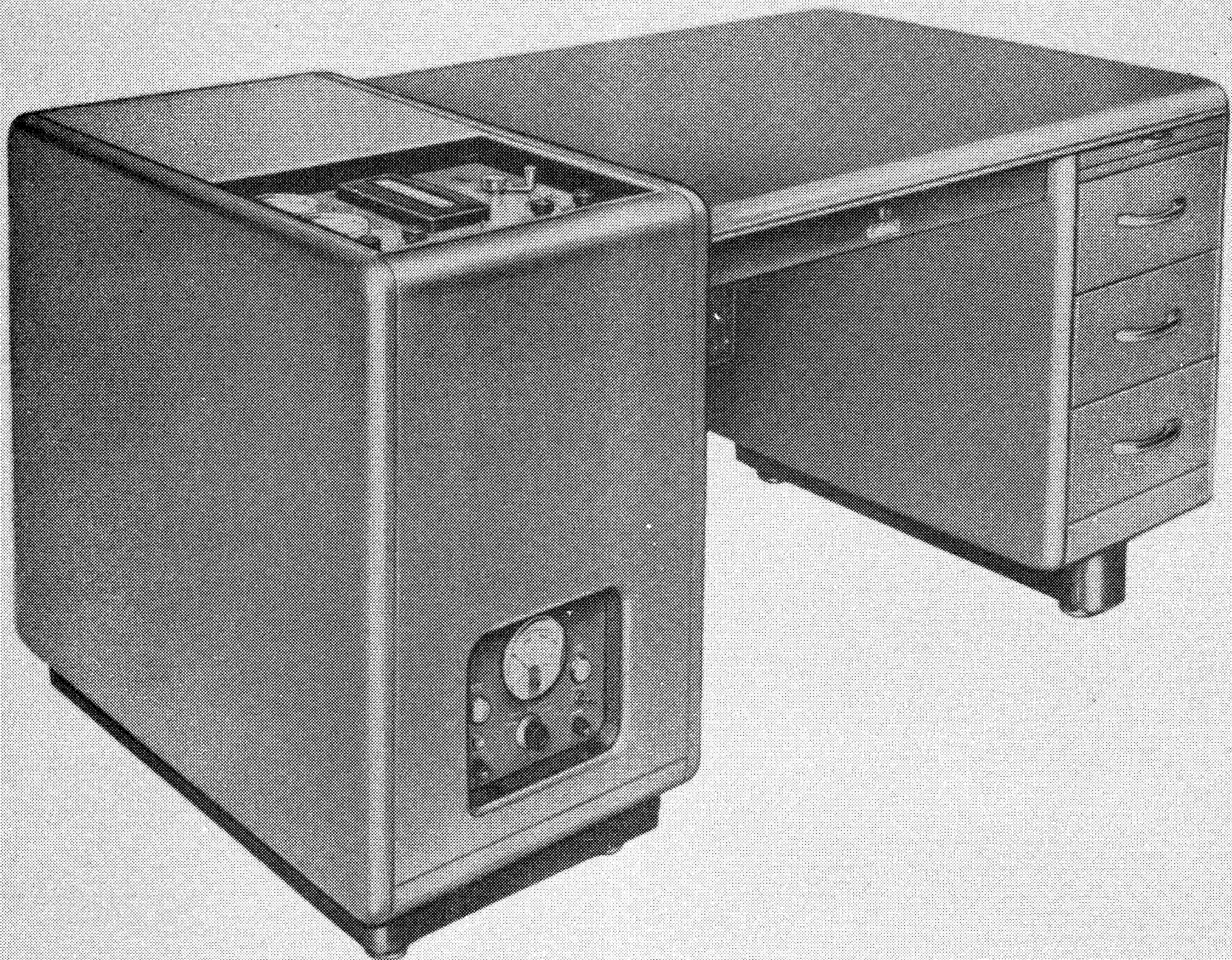

FIGURE 2

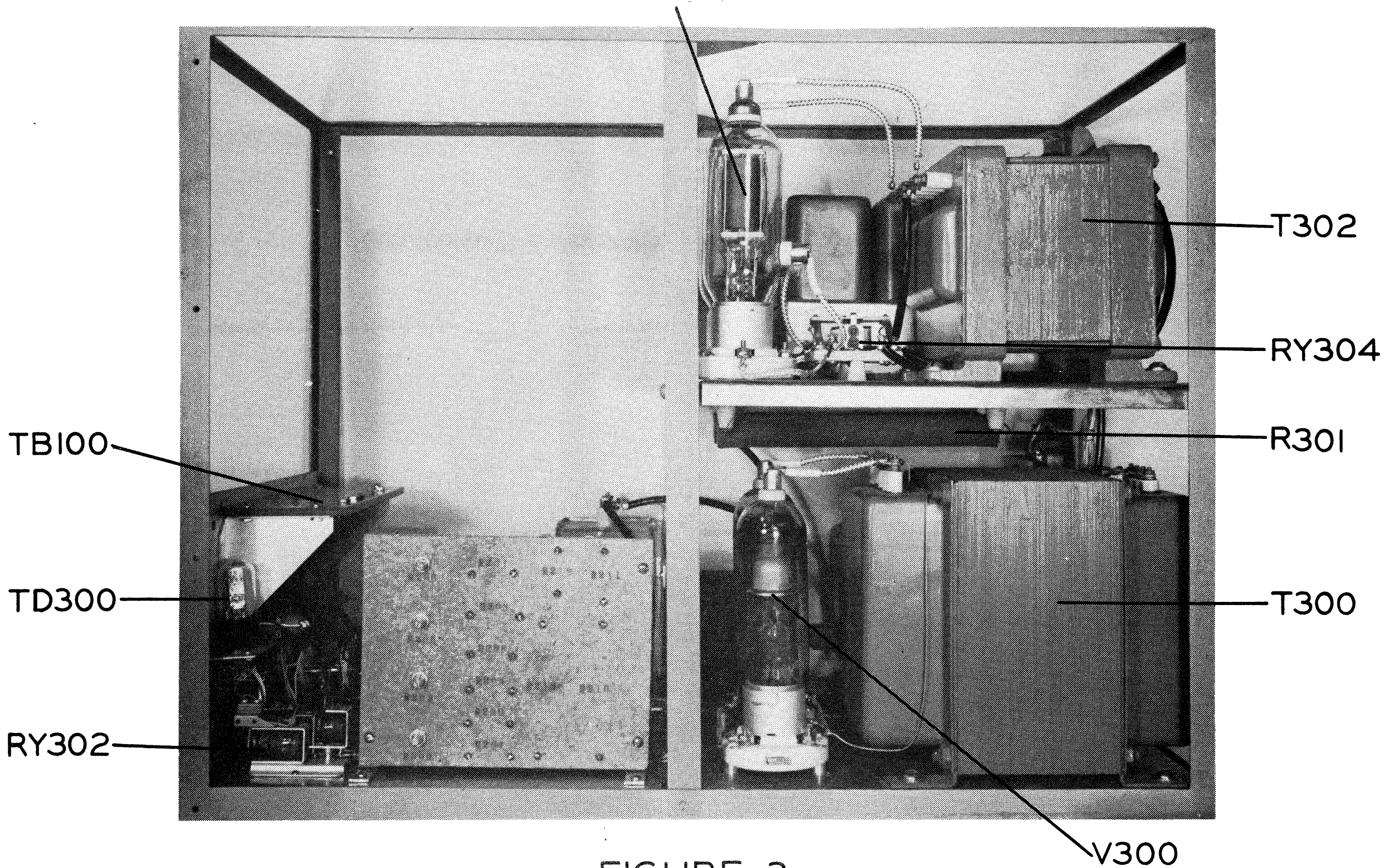

FIGURE 3

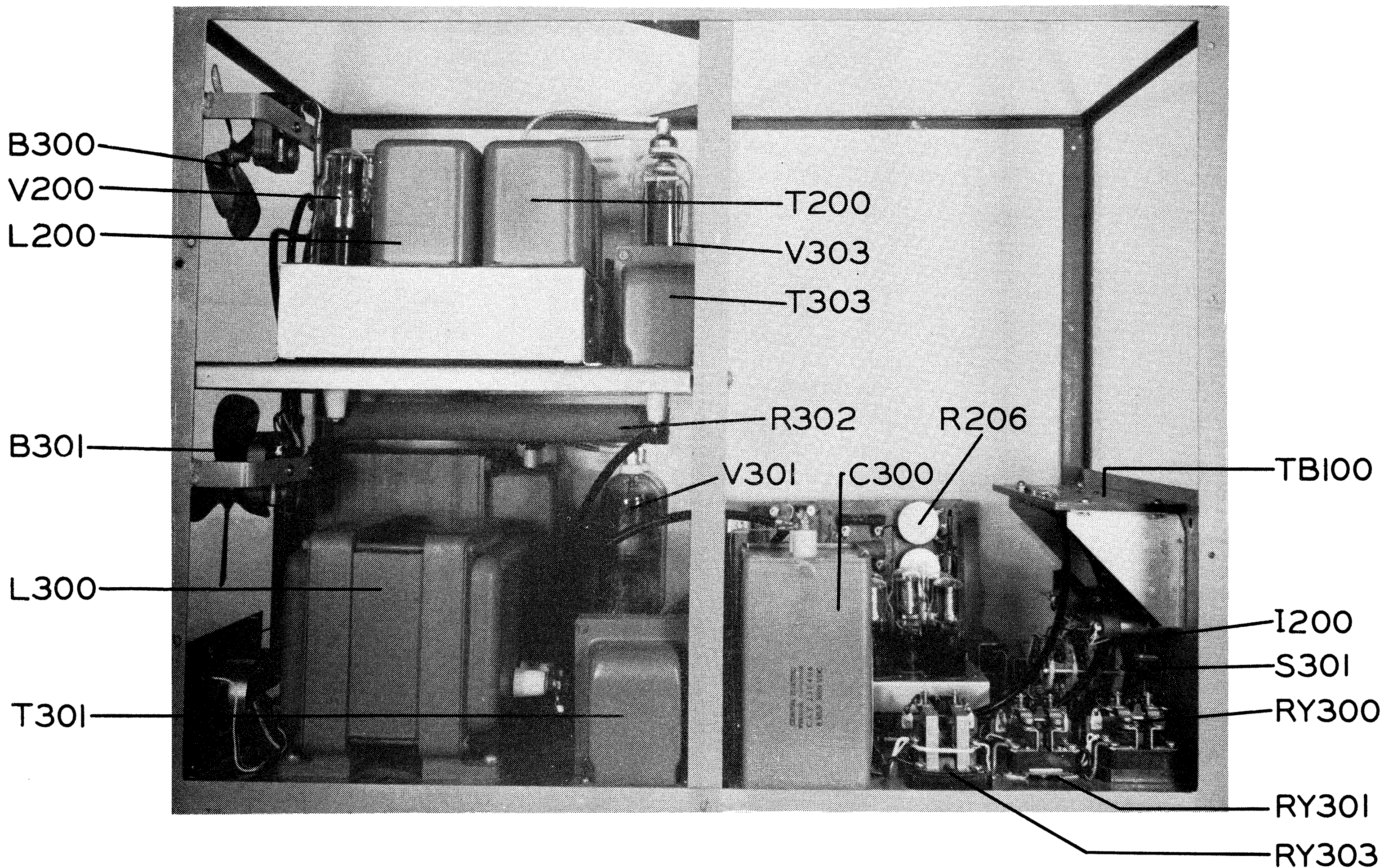

FIGURE 4

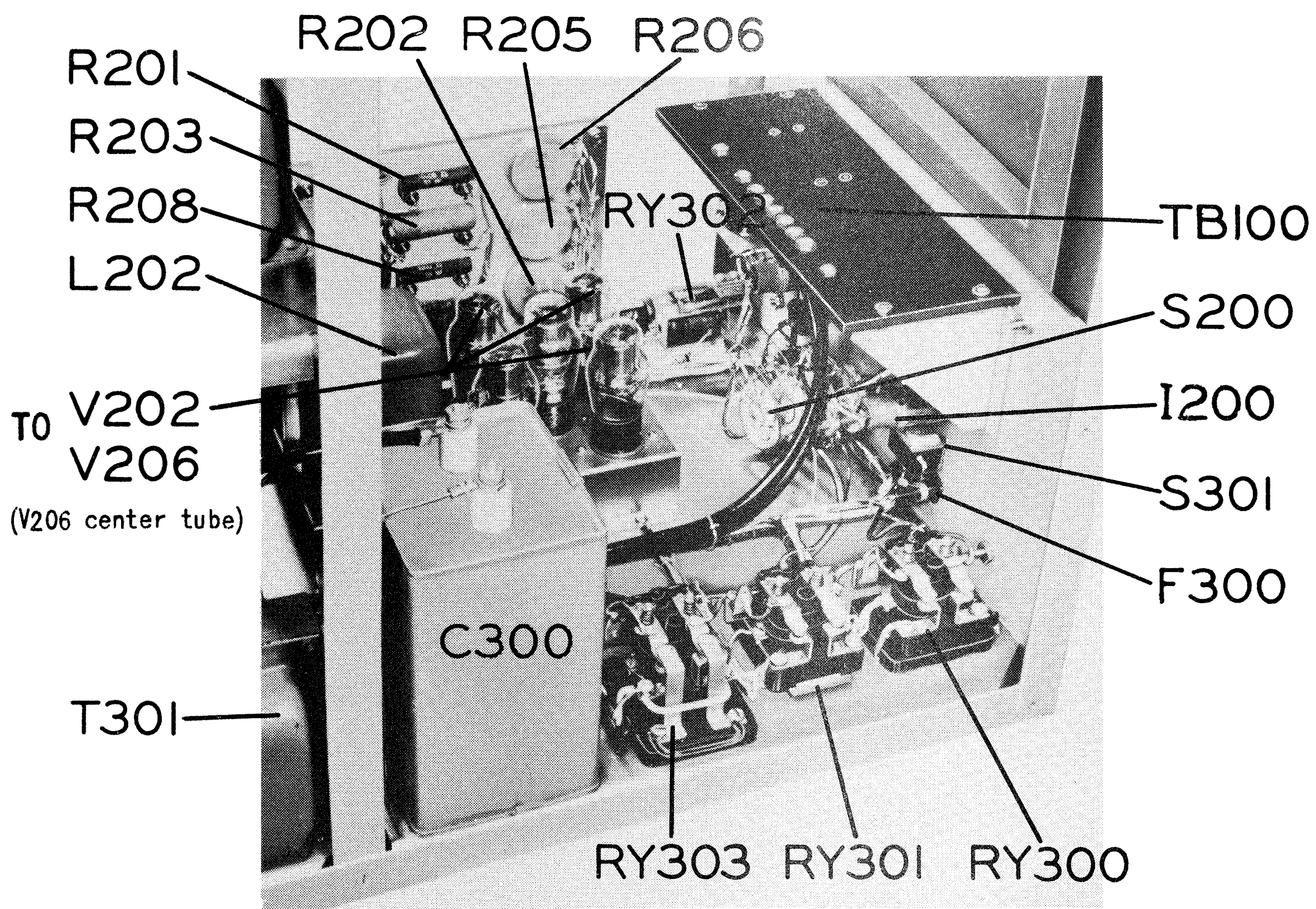

FIGURE 5

FIGURE 6

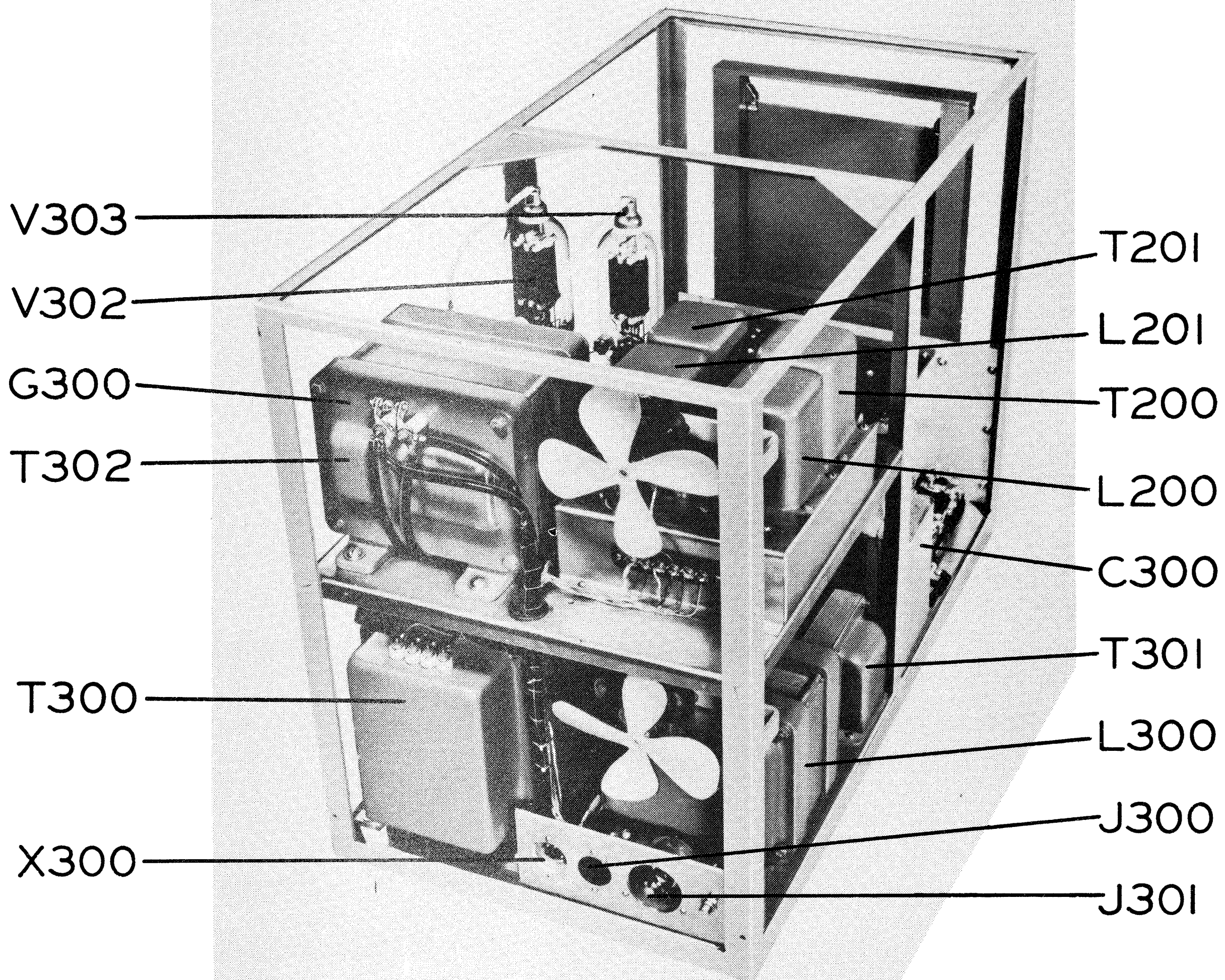

FIGURE 7

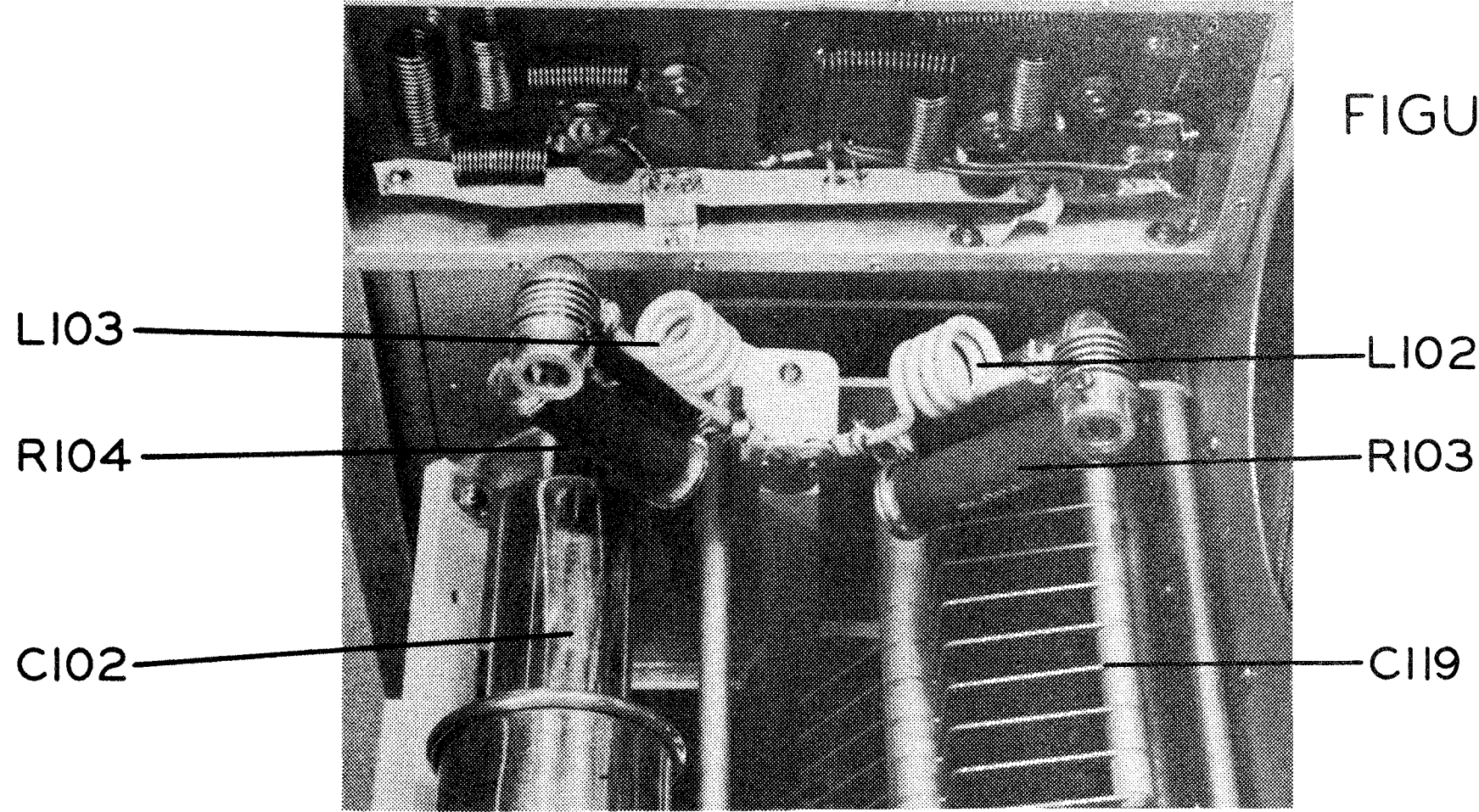

FIGURE 8

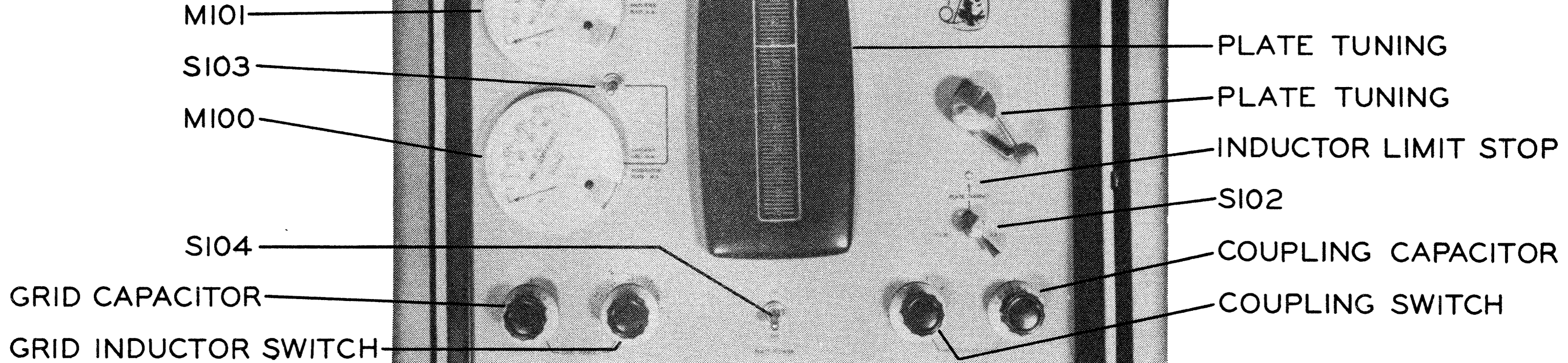

FIGURE 9

M300

I200

S301

F300

S200

I201

S302

F301

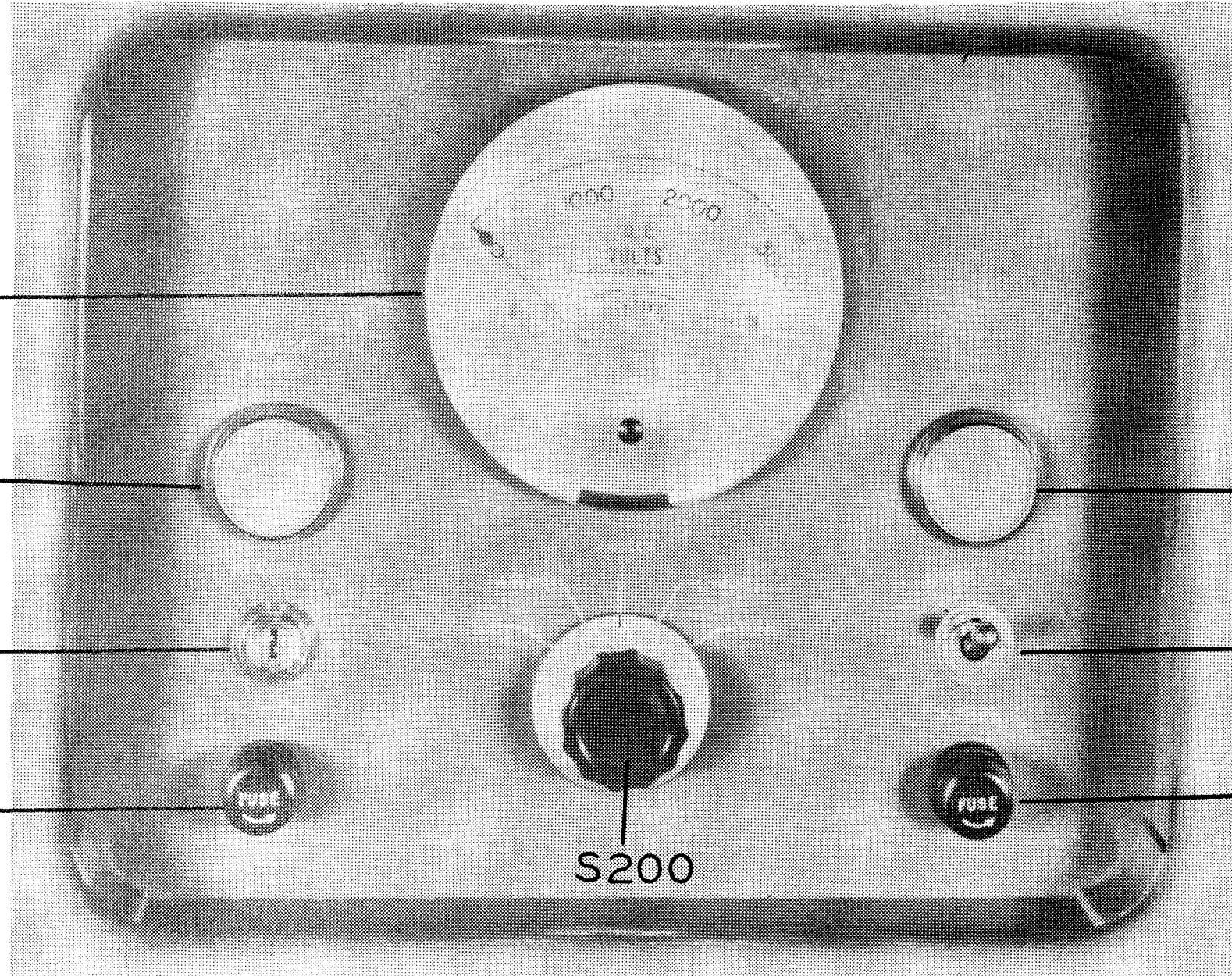

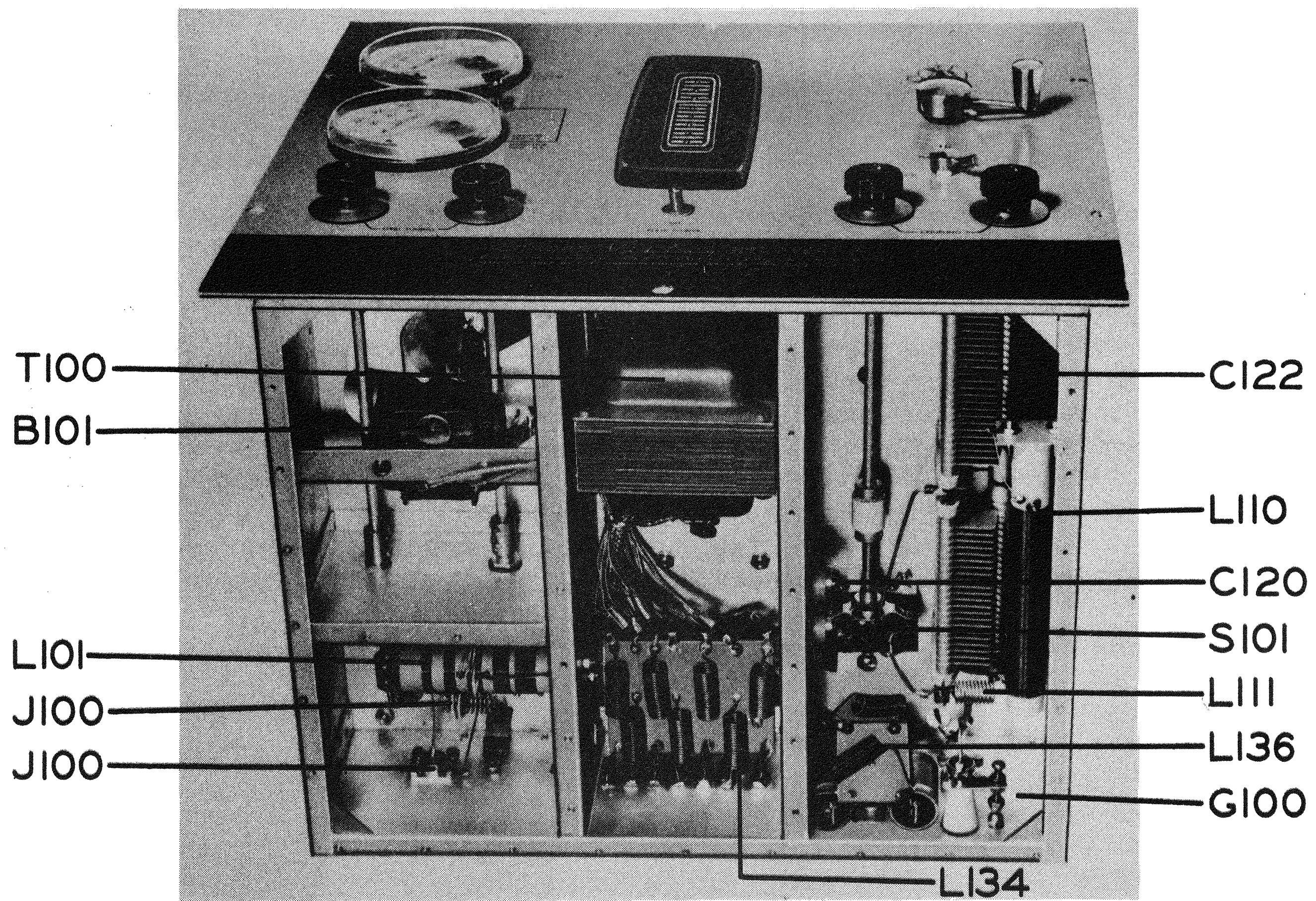

FIGURE 10

C112-C113

C106-C107

C114-C115

C103

L112

B100

L106-R107

R102

R105

L104

C101

R110

L105-R106

FIGURE II

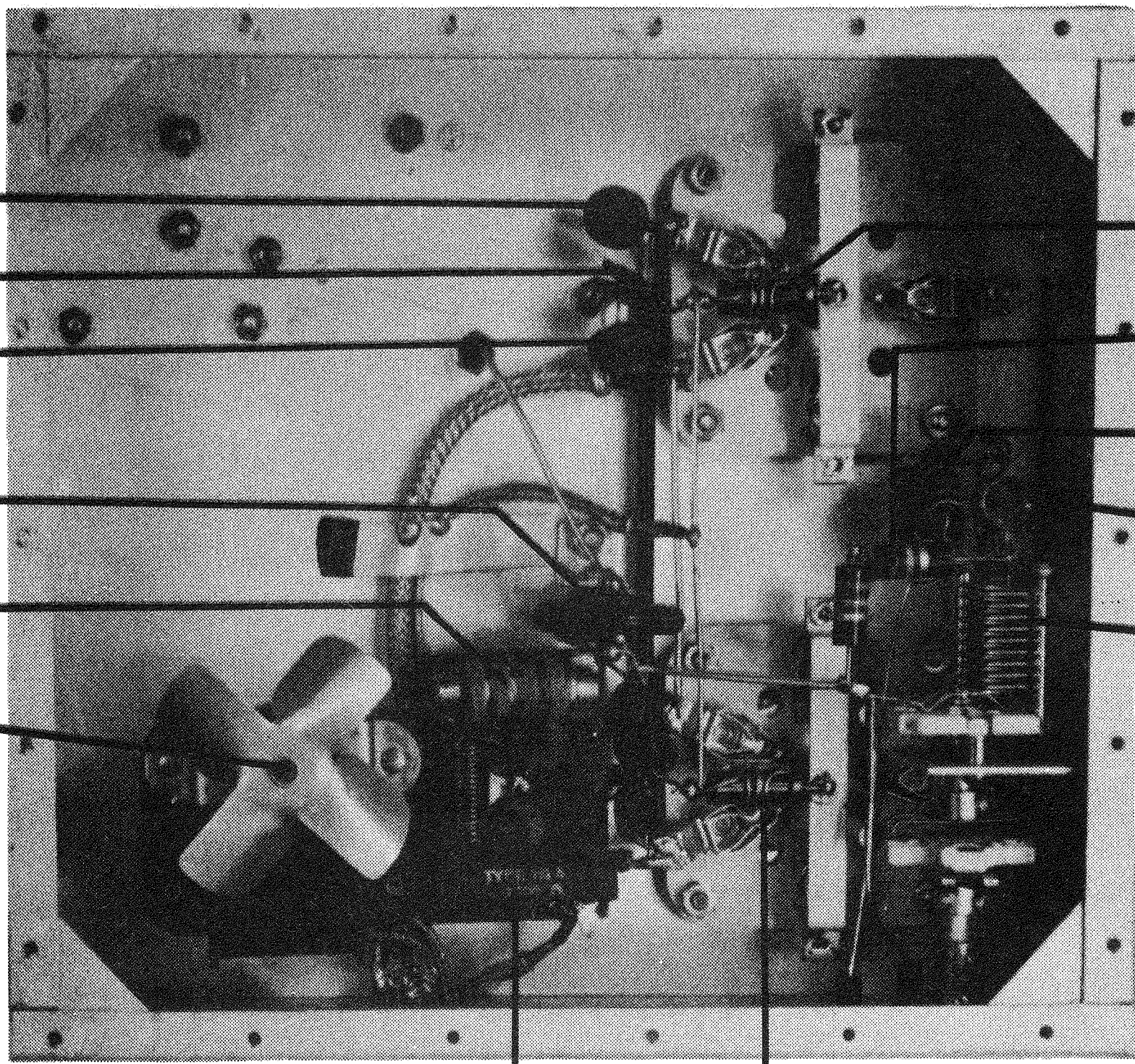

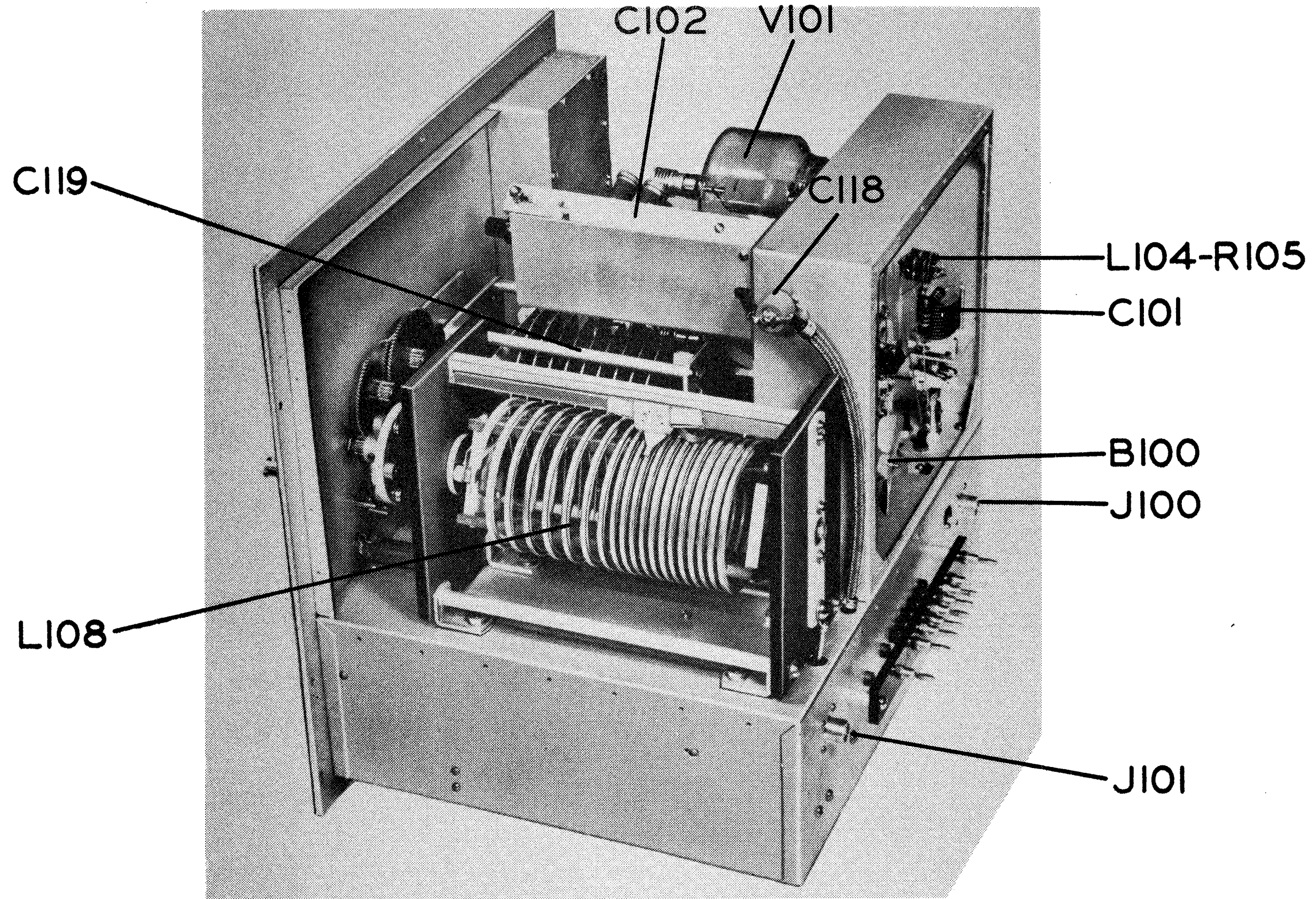

FIGURE 12

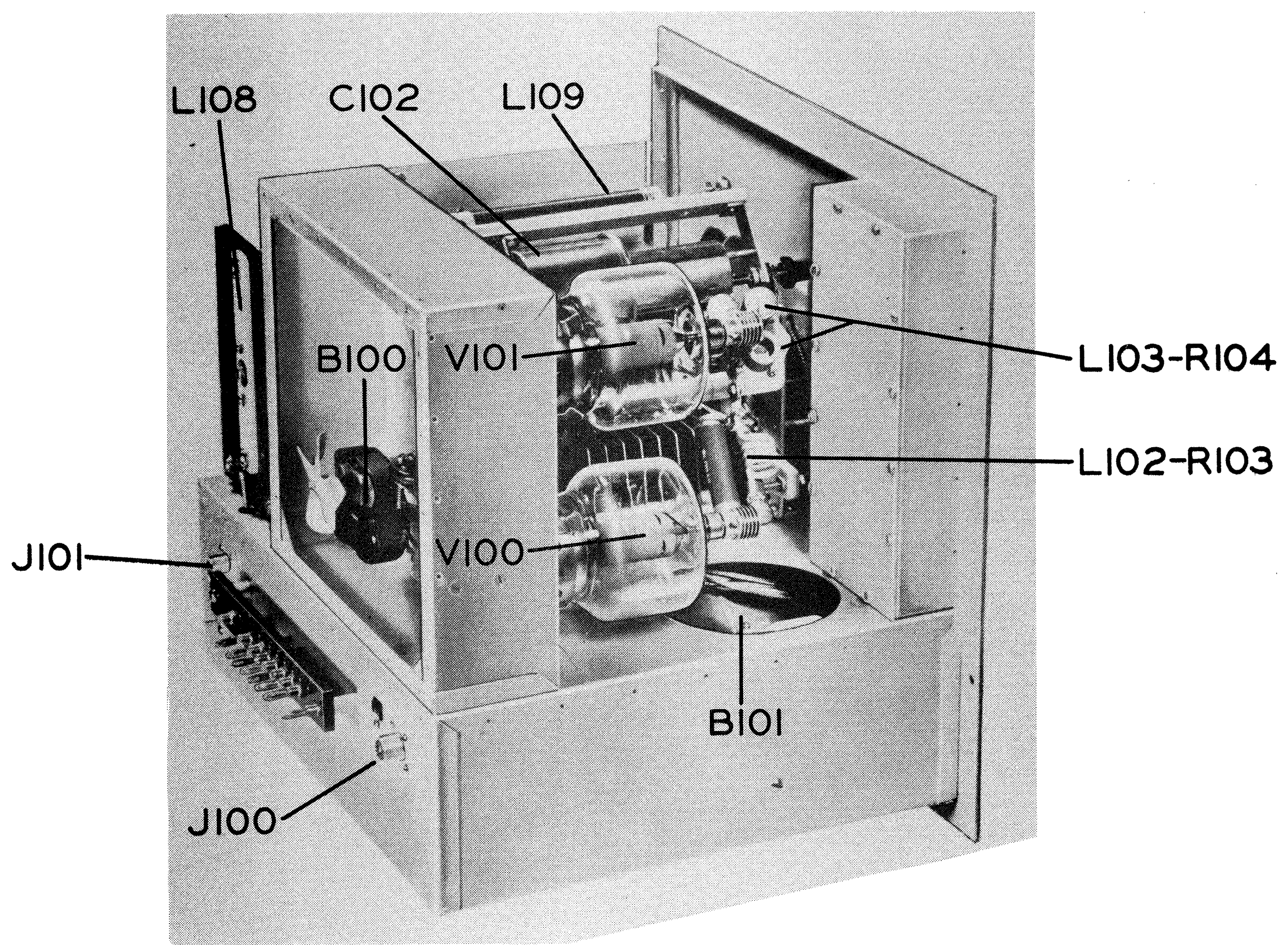

FIGURE 13

TABLE A

TYPICAL DIAL POSITIONS
VIKING KILOWATT AMPLIFIER
50 OHM LOAD

FREQUENCY MCS.	GRID CAPACITOR	GRID INDUCTOR	PLATE DIAL	COUPLING SWITCH	COUPLING CAPACITOR	PLATE-TANK SWITCH
3.5	70	4.7	98	3	52	3.5
4.0	28	4.7	88	3	40	3.5
7.0	42	8.8	51	2	88	3.5
7.3	30	8.8	49	2	88	3.5
14.0	22	15.8	20.5	2	50	3.5
14.35	19	15.8	20	2	48	3.5
21.0	11	22	15	1	61	30
21.45	9	22	14	1	61	30
26.96	34	30	8.5	1	35	30
27.23	29	30	8.3	1	35	30
28.0	24	30	7.5	1	35	30
29.7	8	30	5.5	1	37	30

NOTE: These dial settings should be considered as approximate positions and are only for general preliminary adjustments. Grid settings will vary with different exciters and tank settings with various output loads.

The plate dial positions on 10 meters should agree within 1 or 2 numbers of the published values. If an apparent resonance is secured outside this range, the coupling switch and/or condenser should be changed to secure resonance closer to the chart plate dial settings.

TABLE B

TYPICAL RANGER EXCITER DIAL POSITIONS

FREQ. MCS.	3.5	4.0	7.0	7.3	14.0	14.35	21.0	21.45	26.96	27.23	28.0	29.7
FINAL TUNING	2	65	45	51	58	62	68	65	73	75	76	80
AUX. COUPLING	1	1	2	2	7	7	6	6	7	7	7	7
COUPLING	0	0	0	0	7	7	0	5	5	5	5	7

FIGURE 14

TABLE C
TYPICAL OPERATING VALUES

	TUNE (CW-LO)	CW-HI		AM-LO	AM-HI		SSB	
		TRANS.	NO EXCITATION		TRANS.	NO EXCITATION	TRANS.	NO EXCITATION
E_B (AMP.) VOLTS	1300	2500	2600	1300	2500	2600	2500	2500
$I_{CATH.}$ MA.	330	480	95	330	495	100	415	150
I_{PLATE} MA.	235	400	95	235	400	100	400	150
E_{G2} VOLTS	250	350	500	250	400	450	600	600
E_{G1} VOLTS	105	150	90	105	200	82	102	102
E_{G1} (FIXED) VOLTS	60	95	90	60	90	82	102	102
I_{G1} MA.	20	20	0	20	20	0	1-2 *	0
E_{BIAS} SUPPLY VOLTS	150	150	150	150	150	150	150	150
E_{SCREEN} SUPPLY VOLTS	520	510	590	520	550	550	720	720
E_B (MOD.) VOLTS	1300	2500	2600	1300	2500	2600	2500	2500
I_P (MOD.) MA.	25	55	110	90-100*	175-200*	110	45	75
E_G (MOD.) VOLTS	33	65	60	33	65	60	65	65
AMP. DISP. WATTS	---	---	245	---	---	260	---	375
MOD. DISP. WATTS	---	135	285	---	---	285	---	188
AMP. INPUT WATTS	300	1000	---	300	1000	---	1000	---

* These current values are the peak meter indications at 100% modulation using speech input.

FIGURE 15

Lift from top of R202 at clip 12 to Pin 6 of X300
 A lead from 2 of X300 to clip 12
 A lead from top R202 to 7 x300

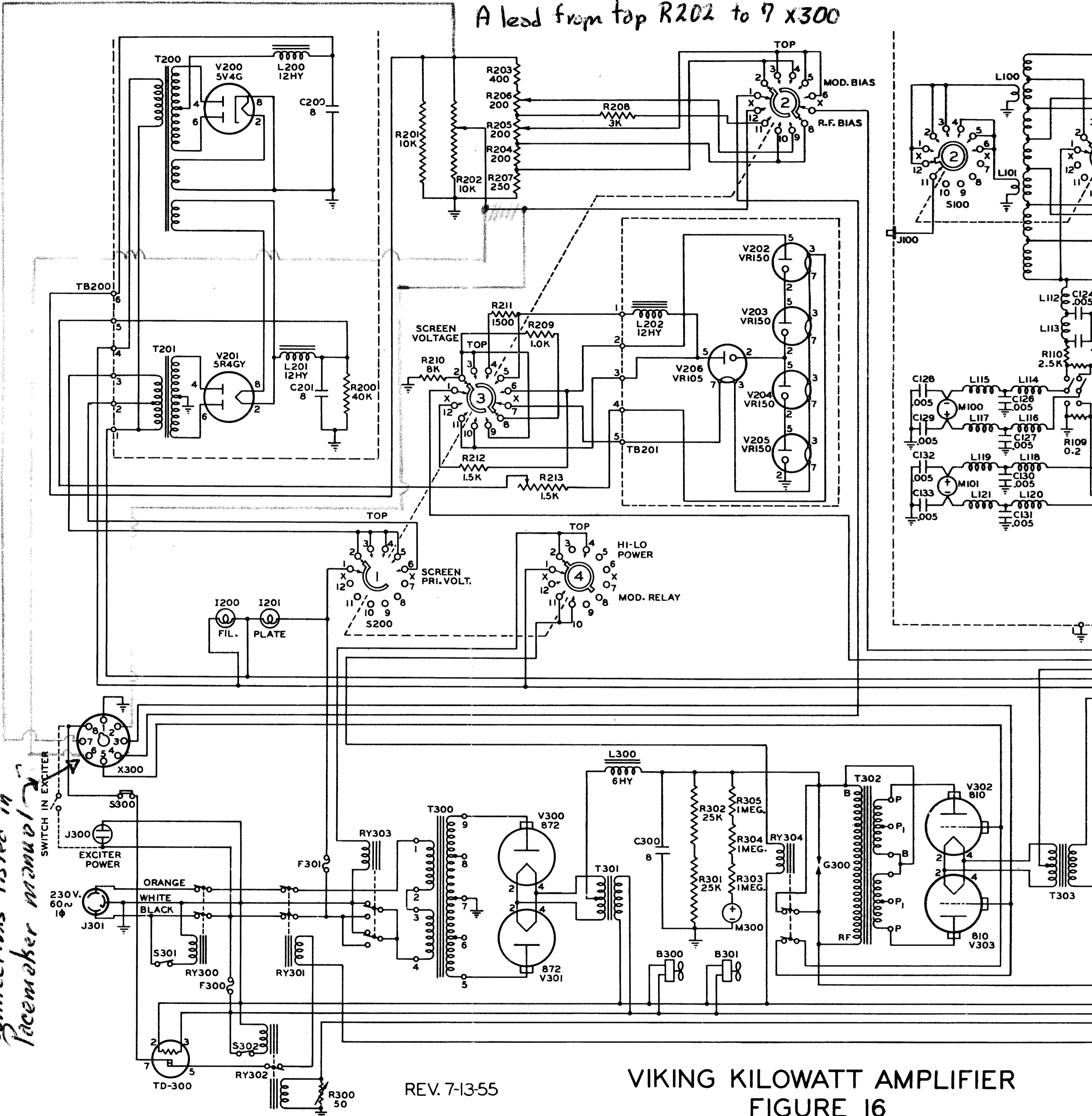

Will correspond to connections listed in Pacemaker manual

REV. 7-13-55

VIKING KILOWATT AMPLIFIER
 FIGURE 16

from top of R202 at clip 12 to Pin 6 of X300

from 2 of X300 to clip 12

from top R202 to 7 X300

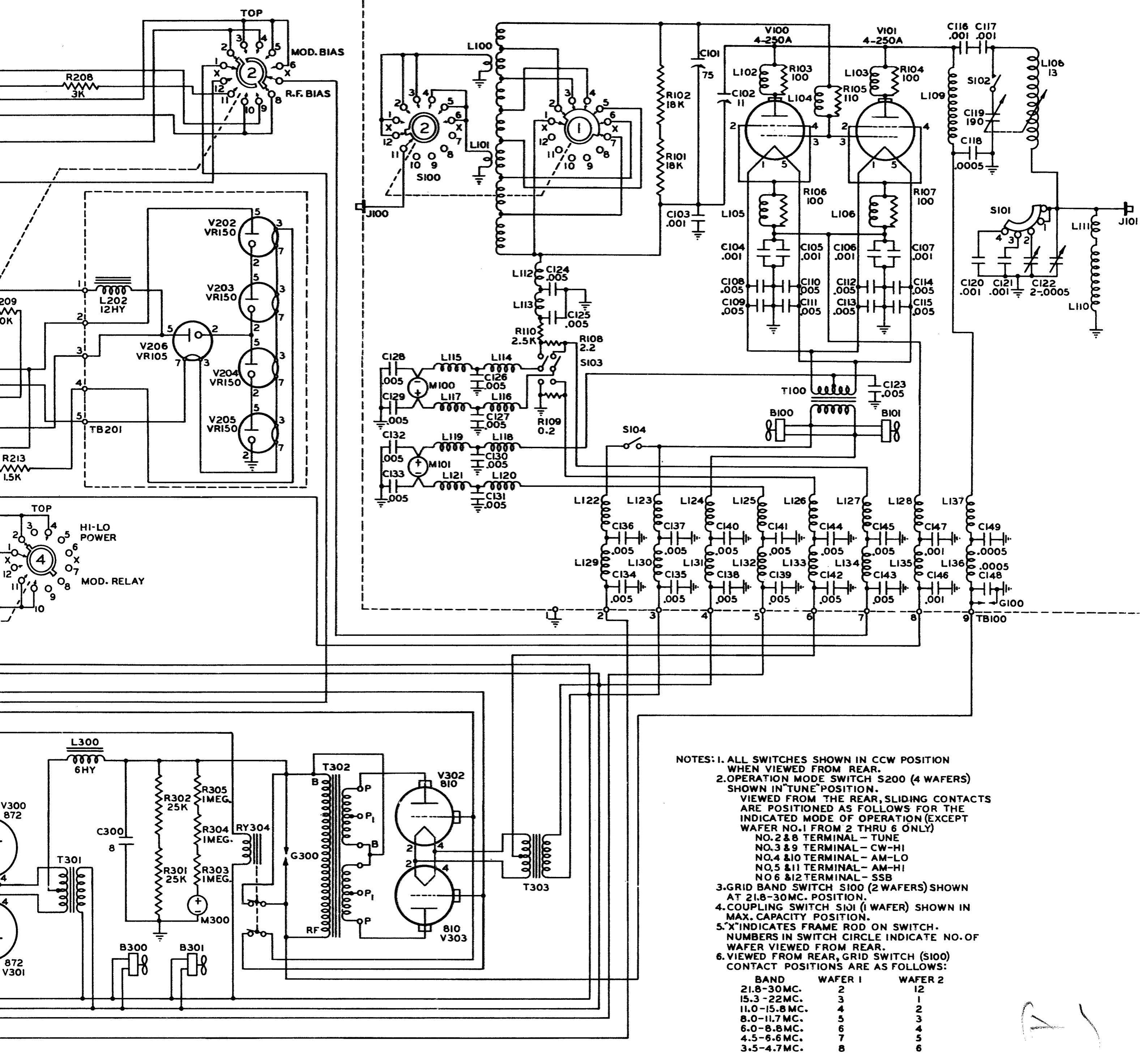

NOTES: 1. ALL SWITCHES SHOWN IN CCW POSITION WHEN VIEWED FROM REAR.
 2. OPERATION MODE SWITCH S200 (4 WAFERS) SHOWN IN "TUNE" POSITION. VIEWED FROM THE REAR, SLIDING CONTACTS ARE POSITIONED AS FOLLOWS FOR THE INDICATED MODE OF OPERATION (EXCEPT WAFER NO.1 FROM 2 THRU 6 ONLY)
 NO.2 & 8 TERMINAL - TUNE
 NO.3 & 9 TERMINAL - CW-HI
 NO.4 & 10 TERMINAL - AM-LO
 NO.5 & 11 TERMINAL - AM-HI
 NO.6 & 12 TERMINAL - SSB
 3. GRID BAND SWITCH S100 (2 WAFERS) SHOWN AT 21.8-30MC. POSITION.
 4. COUPLING SWITCH S101 (1 WAFER) SHOWN IN MAX. CAPACITY POSITION.
 5. "X" INDICATES FRAME ROD ON SWITCH. NUMBERS IN SWITCH CIRCLE INDICATE NO. OF WAFER VIEWED FROM REAR.
 6. VIEWED FROM REAR, GRID SWITCH (S100) CONTACT POSITIONS ARE AS FOLLOWS:

BAND	WAFER 1	WAFER 2
21.8-30MC.	2	12
15.3-22MC.	3	1
11.0-15.8 MC.	4	2
8.0-11.7 MC.	5	3
6.0-8.8MC.	6	4
4.5-6.6 MC.	7	5
3.5-4.7MC.	8	6

VIKING KILOWATT AMPLIFIER
 FIGURE 16

CALIBRATION CHARTS

KILOWATT AMPLIFIER DIAL POSITIONS

OHM LOAD

FREQUENCY MCS.	GRID CAPACITOR	GRID INDUCTOR	PLATE DIAL	COUPLING SWITCH	COUPLING CAPACITOR	PLATE-TANK SWITCH

RANGER EXCITER DIAL POSITIONS

FREQ. MCS.	3.5	4.0	7.0	7.3	14.0	14.35	21.0	21.45	26.96	27.23	28.0	29.7
FINAL TUNING												
AUX. COUPLING												
COUPLING												

FIGURE 17

QUESTIONNAIRE ON VIKING KILOWATT POWER AMPLIFIER

Your cooperation in returning this questionnaire along with your warranty card to the E. F. Johnson Company at your earliest convenience will help us in designing our future amateur equipment.

1. Was your Kilowatt Amplifier delivered from your distributors stock? _____
2. If not, how long did you wait for delivery? _____
3. Was the workmanship satisfactory? _____
4. Were there any obvious defects? _____
5. Was there any shipping damage? _____
6. Was any difficulty experienced in assembling the amplifier? _____

7. Was any difficulty experienced in placing the amplifier on the air? _____

8. Are the colors used on the cabinet and panel pleasing? _____
9. Is the panel layout pleasing? _____
10. Are the controls convenient to use? _____

11. Is the matching accessory desk used? _____
12. If so, is the desk to the left or right of the amplifier? _____
13. What make and model of receiver do you use? _____
14. What exciter is used with the amplifier? _____
15. What percentage of time is spent operating SSB _____ AM _____ CW _____ ?
16. What percentage of time is spent operating Low Power _____ High Power _____ ?
17. Are you entirely satisfied with your Kilowatt Power Amplifier and its performance on the air? _____

18. What features do you find the most desirable in this amplifier? _____

19. What features do you like least in this amplifier? _____

20. What improvements would you recommend in this amplifier? _____

21. What amateur transmitter do you believe to be the best buy on the market considering its price, power and features? _____

22. What type of antenna(s) is used with this amplifier? _____

23. Are you using an antenna coupler? _____

24. What operating accessories (such as monitors, calibrators, etc) do you use?

25. What percentage of operating time is spent of the following? DX _____

Ragchewing _____ Contests _____ Experimenting _____

26. How do you rate Johnson equipments in terms of:

Quality Good _____ Fair _____ Poor _____

Value Good _____ Fair _____ Poor _____

Performance Good _____ Fair _____ Poor _____

Appearance Good _____ Fair _____ Poor _____

27. What additional items of amateur equipment would you like to see on the market?



REPRESENTATIVES:

Atlanta 5, Ga., James Millar Associates, 1036 Peachtree St. N. E., ELgin 0910
Baltimore 14, Md., S. K. Macdonald, Inc., 2016 Winford Rd., CLifton 4-9966
Boston 16, Mass., Paul R. Sturgeon, 25 Huntington Ave., COMmonwealth 6-7705
Cedar Rapids, Ia., Jerry Vrbik, 621 Guaranty Bldg., 40833
Chicago 31, Ill., Ellinger Sales Corp., 6540 N. W. Highway, RODney 3-1570
Columbus 15, Ohio, William E. McFadden, 150 East Broad St., CAPitol 1-3363
Dallas 1, Texas, Robert E. Nesbitt Co., 1925 Cedar Springs, PROspect 5824
Detroit 38, Mich., A. B. M. Sales Co., 2450 Fenkell Ave., UNiversity 2-1300
Kansas City 8, Mo., H. A. Roes & Co., 2601 Cherry St., HARRison 2036
Los Angeles 15, Calif., Don C. & William H. Wallace, Bendix Building,
1206 Maple Ave., RICHmond 7-0401
Milford, Conn., Paul R. Sturgeon, 2½ Broad St., P. O. Box 170, MILford 2-6080
Minneapolis 16, Minn., Fred B. Hill Co., 6110 Excelsior Blvd., MOhawk 9-6727
New York 6, N. Y., F. Edwin Schmidt Co., 136 Liberty St., WORth 2-6550
Philadelphia 2, Pa., S. K. Macdonald, Inc., 1531 Spruce St., KINGsley 5-1205
Phoenix, Arizona, Harry A. Moore Sales, P. O. Box 7245, AMherst 5-4662
Pittsburgh 22, Pa., S. K. Macdonald, Inc., 715 State Theatre Bldg., ATLantic 1-2253
Portland 10, Oregon, Dave M. Lee, 2712 Northwest Raleigh St., BEacon 2241
San Francisco 2, Calif., Logan Sales Co., 154 8th St., HEMlock 1-1527, 1-0692
Seattle 1, Wash., Dave M. Lee, 2517 Second Ave., MAIn 5512
South Plainfield, N. J., F. Edwin Schmitt Co., 130 Madison Drive
St. Louis 10, Mo., H. A. Roes & Co., 4030 Chouteau, Room 512, OLive 2-0784
Syracuse 4, N. Y., Wally B. Swank, 2310 Bellevue Ave., 4-2141
Washington 10, D. C., S. K. Macdonald, Inc., 217 Riggs Bank Building,
14th & Park Rd., COLumbia 5-3938

CANADA

Toronto 12, Ont., Canada, A. C. Simmonds & Sons Ltd., 100 Merton St., MAYfair 9111

EXPORT

New York 7, N. Y., M. Simons & Son Co., Inc., 25 Warren St., BARclay 7-5513
Cable Address—Simonrice

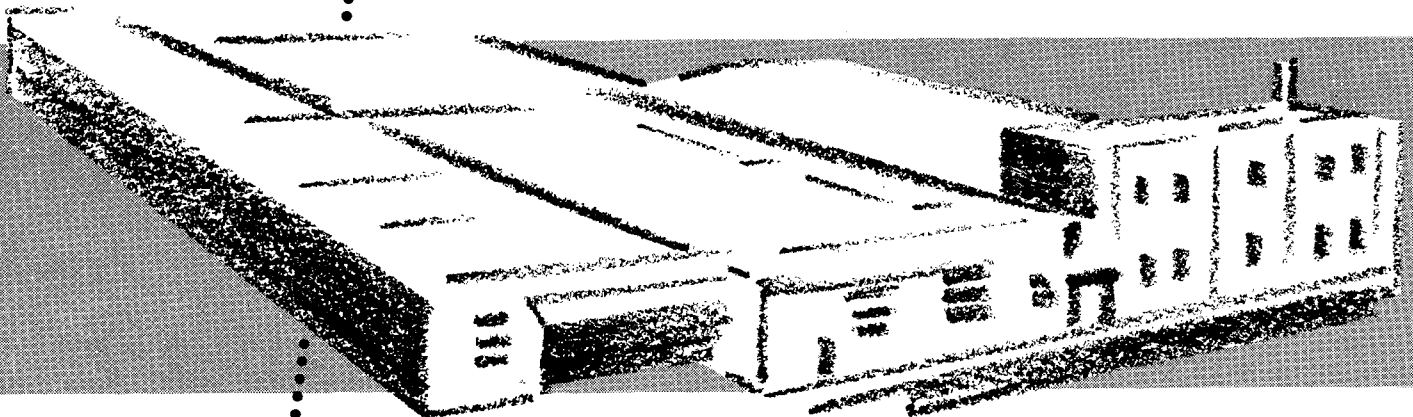

E. F. JOHNSON COMPANY
WASECA, MINNESOTA • U. S. A.