

## LINEAR VHF AMPLIFIERS CLASS "AB" FM/CW/SSB/AM

This series of amplifiers is designed for 143 to 149 Mhz 2 meter band operation. The designs use the latest in micro-stripline techniques and highest quality state of the art transistors. Relay switching is automatic RF sensing. These units do not require any tuning. The boardband design offers the ultimate in flat input VSWR, 1.4:1 or less, and produces rated power output or better across the entire two meter band. This amplifier can be used for AM or SSB operation as well as FM and CW.

The front panel switch on all models switches the amplifier in or out. With the switch "in", the 13.5 VDC is supplied to the RF sensing and relay circuit inside the amplifier, however, the unit will not draw any current until the transceiver or transmitter is keyed and RF is applied to the amplifier. At this point an audible click of the relay can be heard and the LED light on the front panel will light. The amplifier will now amplify the RF applied. In the "out" position, the amplifier will bypass the RF through the amplifier.

Forced DC keying can be used by applying + 9 to +15 VDC through a 10k resistor to the base of the MPSA 13 relay driver.

### TYPICAL SPECIFICATIONS FOR ALL MODELS

IMPEDANCE:	50 ohms input and output
SUPPLY VOLTAGE:	13.5 VDC (usable from +11 to +14.5 VDC)
INPUT VSWR:	1.4:1 144-148 MHz
DUTY CYCLE:	CAS (Intermittant Commerical Amateur Service)
RF CONNECTORS:	SO239

MODEL NUMBER	RF POWER INPUT (watts)	USUABLE PWR. INP. (watts)	NOM. PWR. OUTPUT (watts)	NOM. CUR. (amps)	SIZE	FUSE 3AG SIZE (amps)
PA 10-160BL	10	5-15	160	22	6.5x10x2	30
PA 2-70BL	2	1-4	70	10	6.5x7.5x2	15
PA 10-80BL	10	5-15	80	10	6.5x7.5x2	15
PA 10-40BL	10	5-15	40	5	6.5x5x2	7 <sup>1/2</sup>
PA 10-70BL	10	5-15	70	8	6.5x7.5x2	10
PA 10-140BL	10	5-15	140	18	6.5x10x2	25
PA 30-140BL	30	15-45	140	15	6.5x10x2	20

**PA10-70BL/PA10-80BL**

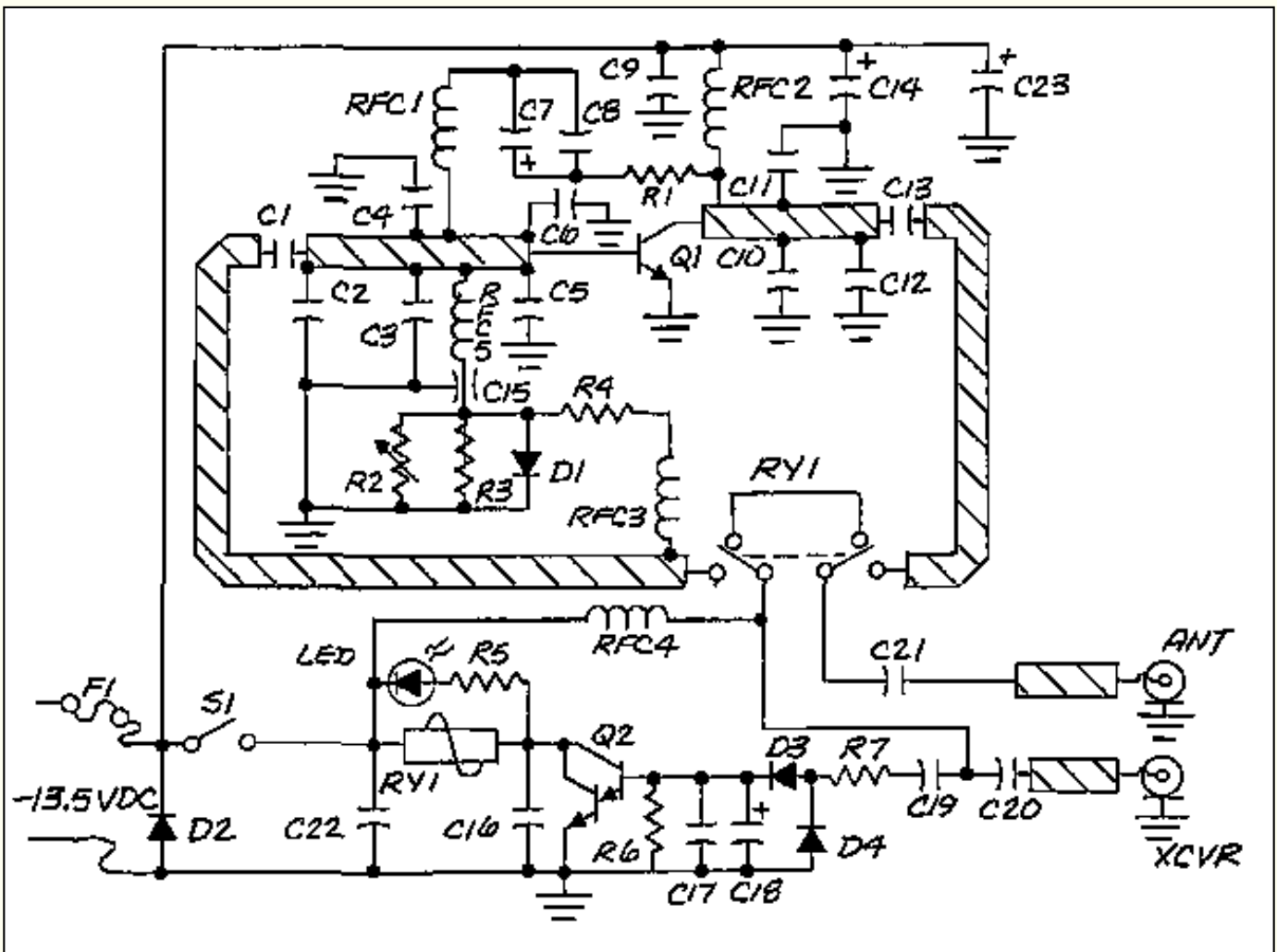

C2,3,4	68 pf	Underwood
C5,6	200 pf	Underwood
C8,9,16,17,22	.001 MFD	disc
C7,14		1/35 VDC TANT
C10,11	100 pf	Underwood
C2,12	47 pf	Underwood
C1,13,20,21	750 pf	DM15
C19	5pf	disc
C23		25/15 VDC Eletrolytic
C18	47 MFD	63 VDC
C15	1000pf	Feed Thru Allen Bradley
D3,4	1N914	
R6	22k	1/4 Watt
R5	560 OHM	1/2 Watt
RFC1,3,5	.15uH	
Q1	MRF245	Motorola
Q2	MPSA13	Motorola
R7	560 OHM	1/4 Watt
R2	100 OHM	Pot
R3	3 OHM	1/4 Watt

R4	50 OHM	5 Watt
S1	Alco	SPDT
LED	MV5053	
R1	15 OHM	1/2 Watt
RFC2	5T#16	1/4" Dia. x 1/2" Ig.
RY1	Relay 1355/1365	
D2,1	1N4003 Diodes	
F1	Fuse	15A
RFC4	4.7uH	

**PA30-140BL**

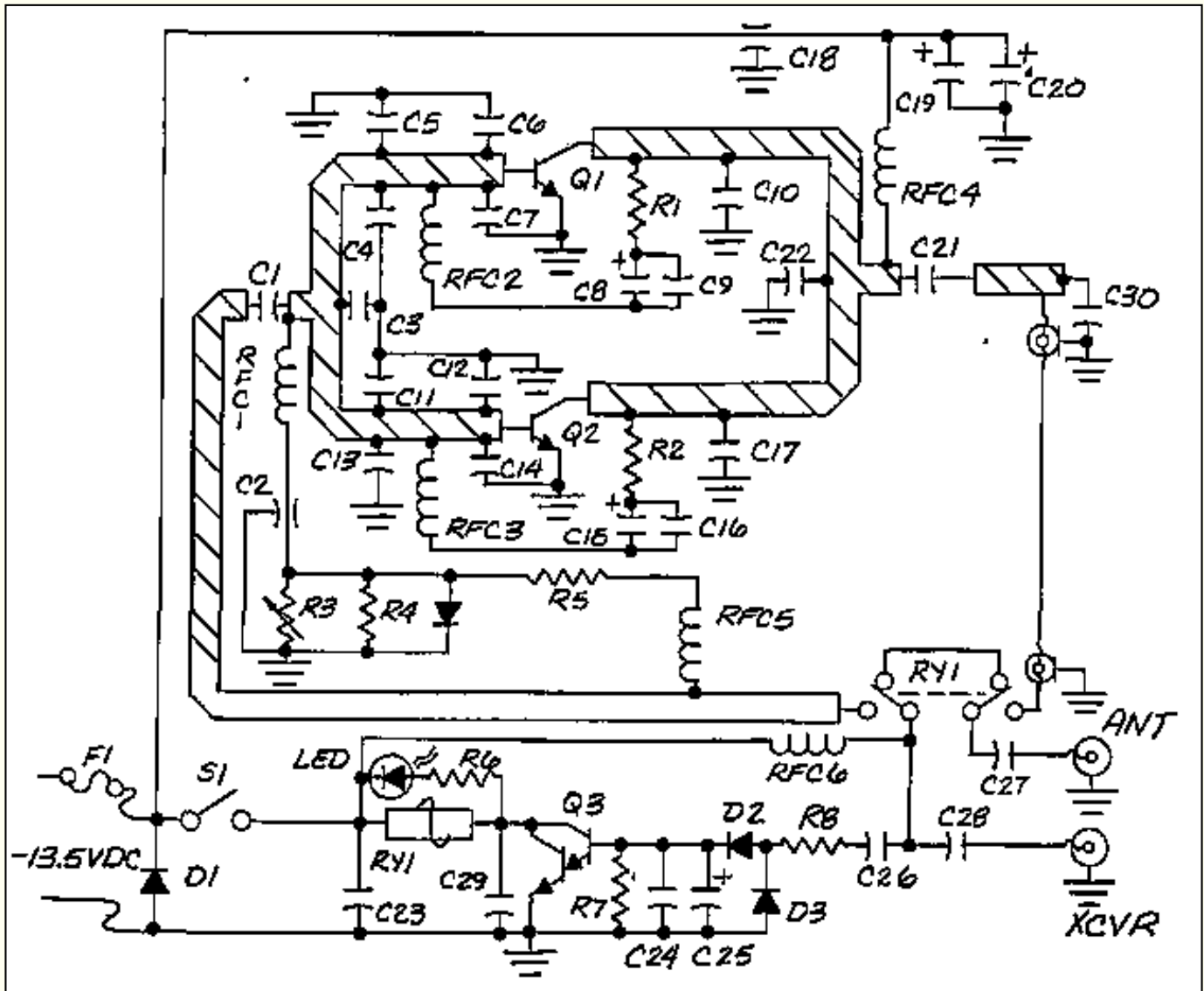

C3,4,5,11,13	68 pf	Underwood
C6,7,12,14,10,17	200 pf	Underwood
C9,16,24,23,29	.001 MFD	disc
C8,15,19		1/35 VDC TANT
C22	47 pf	Underwood

C1,21,27,28	750 pf	DM15
C26	5pf	disc
C20	25 MFD	16 VDC
R7	22k	1/4 Watt
RFC2,3,1,5	.15uH	
RFC6	4.7uH	
Q1,2	MRF245	Motorola
Q3	MPSA13	Motorola
RY1	Relay #1355/1365	Guardian
D2,3	1N914	
D1,4	1N4003	
R8	560 OHM	1/4 Watt
R6	560 OHM	1/2 Watt
R3	100 OHM	Pot
R4	3 OHM	1/4 Watt
R5	50 OHM	5 Watt
R1,2	15 OHM	1/2 Watt
S1	Alco	SPDT
LED	MV5053	
C30	33 pf	Underwood
RFC4	5T#16	1/4" Dia.
C25	47/63V	Electrolytic
C18,2		Feed Thru Allen Bradley
F1	Fuse	15A

---

**PA10-160BL**

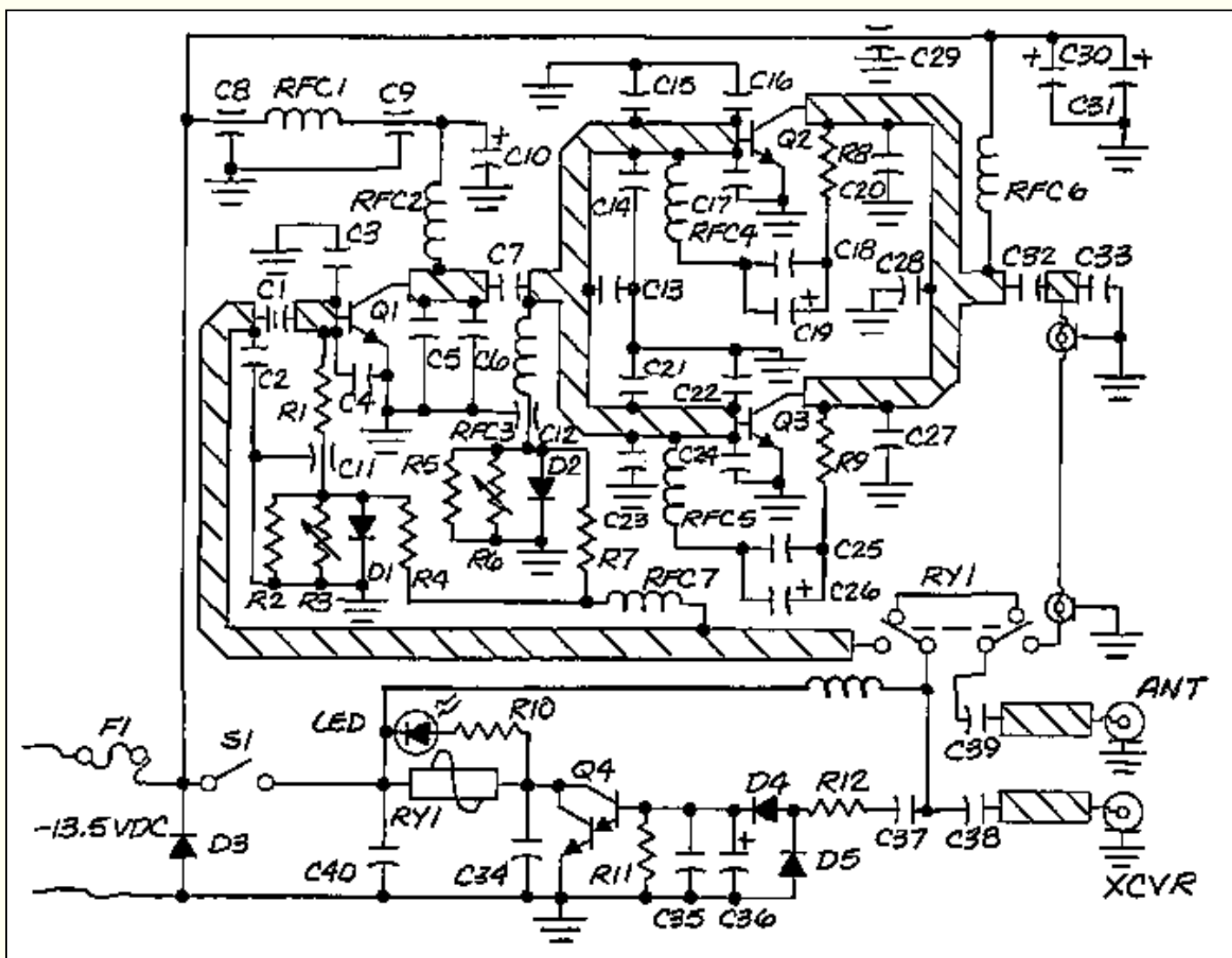

C36	47 MFD	63 VDC
C13,14,15,21,23	68 pf	Underwood
C16,17,22,20, 24,27	200 pf	Underwood
C18,25,34,35,40	.001 MFD	disc
C19,26,30,10		1/35 VDC TANT
C2,6,28	47 pf	Underwood
D1,7,32,38,39	750 pf	DM15
D37 C31	5pf 25 MFD	disc 25 VDC
D8,9,29,11,12	470 pf	Allen Bradley
D5	100 pf	Underwood
R12	560 OHM	1/4 Watt
R10	560 OHM	1/2 Watt
B1	15 OHM	1 Watt
D4,5	1N914	
D1.2.3	1N4003"	
Q2,3	MBF 245	Motorola
Q4	MPSA13	Motorola
Q1	2N6084	Motorola

BFC3,4,5	.15uH	Choke
RFC8	4.7uH	Choke
B11	22k	1/4 Watt
B3,6	100 OHM	Pot
B2,5	3 OHM	1/4 Watt
B4,7	50 OHM	5 Watt
BFC1,2,6	5T#16	1/4" dia.
BY1		Belay 1355/1365
F1		Fuse 25A
LED		LED and Mount MV5053
S1		Alco SPDT

**PA10-40BL**

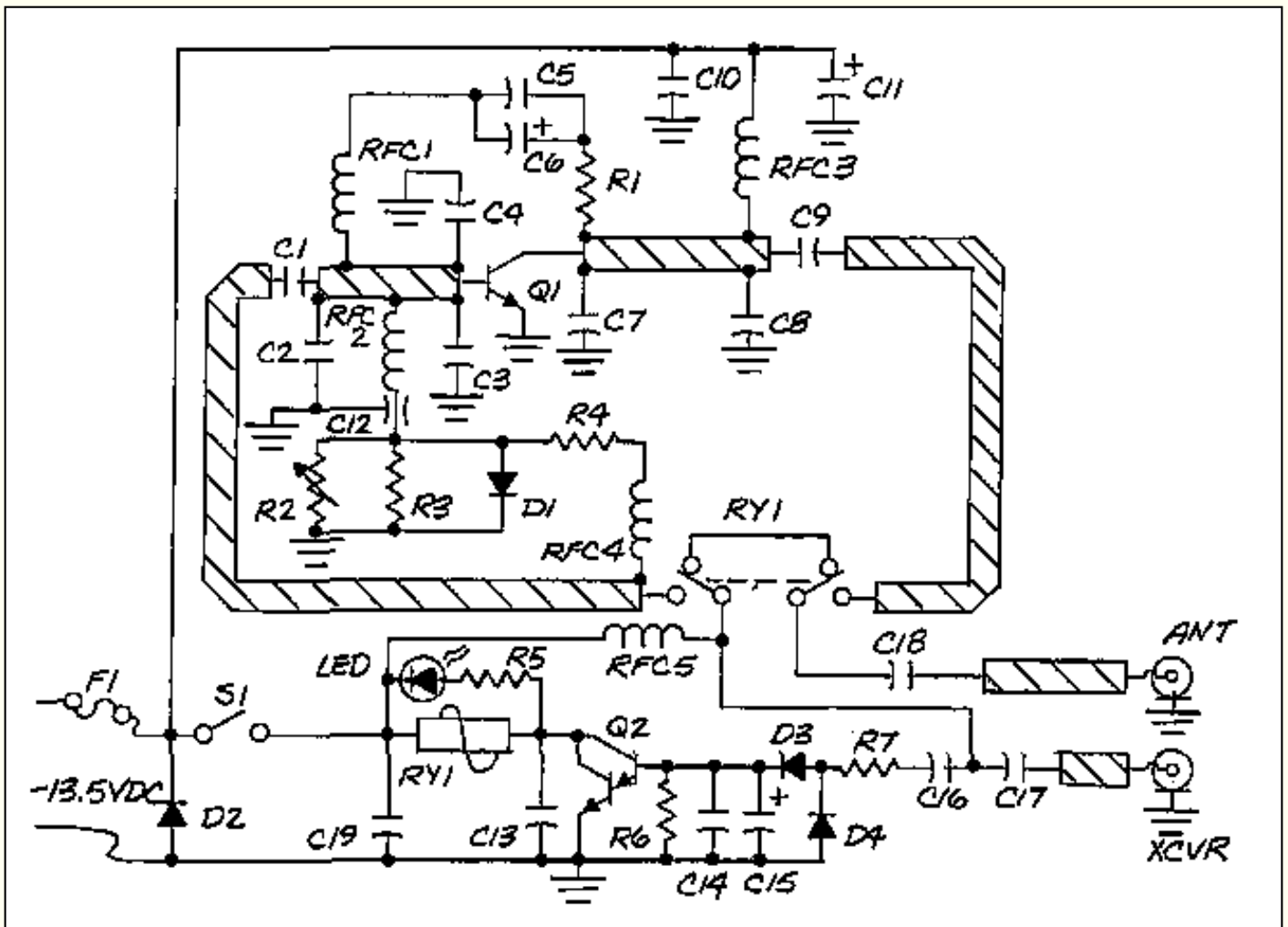

C1,9,17,18	750 pf	DM15
C2,8	68 pf	Underwood J101
C3,4,7	200 pf	Underwood J101
C5	.01	disc
C6.11	1 MFD	35 VDC TANT

C13,19,10	.001 MFD	disc
RFC1,4,2	.15uH	
RFC5	4.7 nH	
C16	5pf	disc
Q1	B40-12	CTC/2N6084
Q2	MPSA13	Motorola
B1	15 OHM	1/2 Watl
B6	22k OHM	1/4 Watt
R5	560 OHM	1/2 Watt
R7	1000 OHM	1/4 Watt
R2	100 OHM	Pot
R3	3 OHM	1/4 Watt
R4	50 OHM	5 Watt
LED	MV5053	
S1	Alco	SPDT
C15	47/63	Electrolytic
D3,4	1N914	
RFC3	5T#16	1/4" Dia.
RY1	Relay 1355/1365	
D4,5	1N4148 or 1N914	
D1,2	1N4003 Diode	
F1	Fuse	7 1/2A
C12		Allen Bradley

---

**PA 2-70BL**

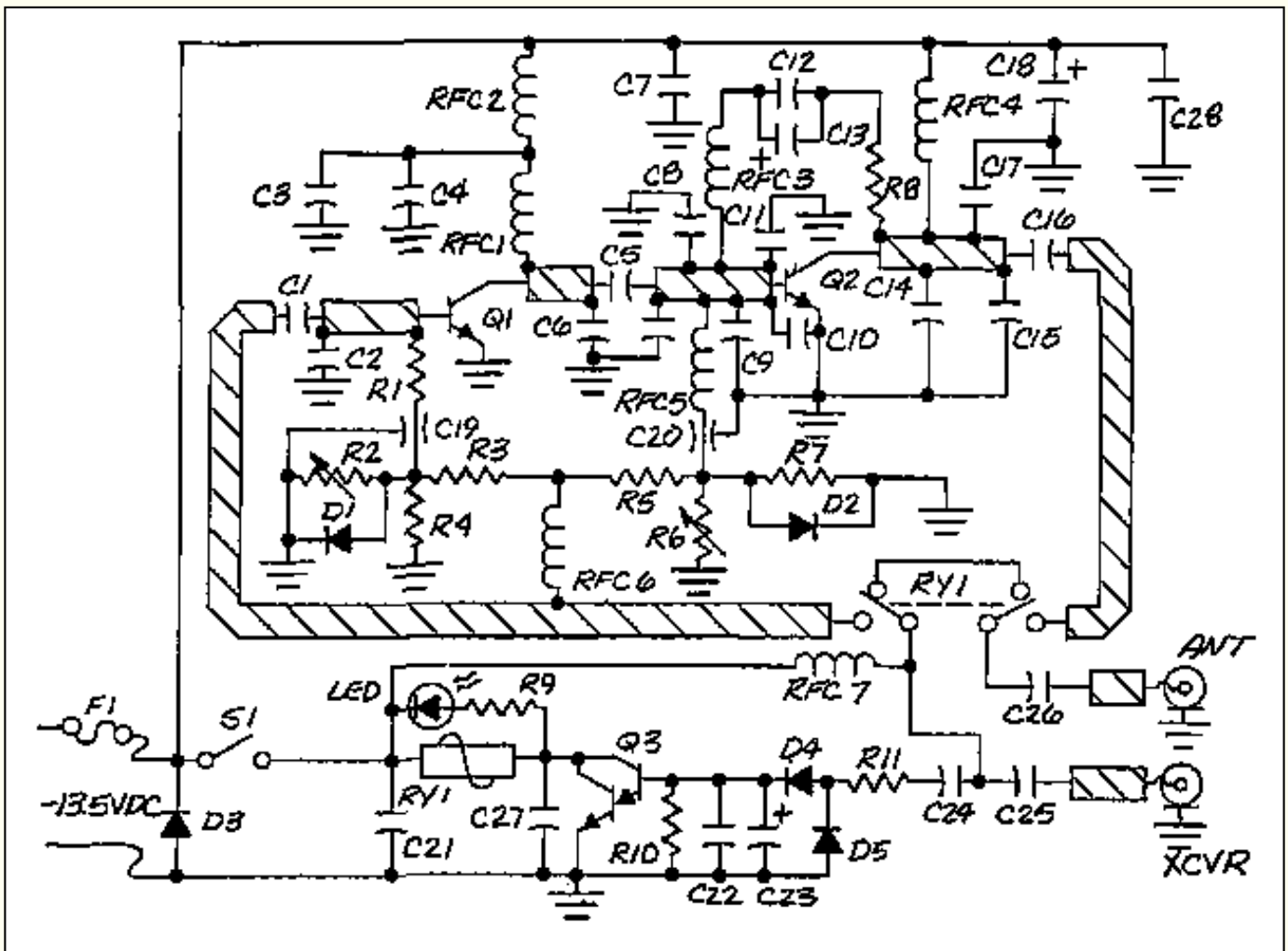

C2,14,17	100 pf	Underwood
C6,15,29	47pf	Underwood
C10,11	200 pf	Underwood
C8,9	66 pf	Underwood
C1,5,16	750 pf	DM15
C3,12,21,22,27,28	.001 MFD	disc
C13,4,18	1 MFD	35 VDC TANT
C24	5pf	disc
C23	47/63V	Electrolytic
R11	560 OHM	1/4 Watl
R10	22k OHM	1/4 Watt
R9	560 OHM	1/2 Watl
R8	15 OHM	1/2 Watt
RFC3,5,6	.15uH	Choke
Q3	MPSA13	Darlington
RFC7	4.7uH	Choke
C7	22 MFD	16 VDC
D4,5	1N914	
Q1	B12-12	
Q2	MRF245	



R2,6	100 OHM	Pot
R3,5	50 OHM	5 Watt
R4,7	3 OHM	
LED	MV5053	
S1	Alco	SPDT
RFC1,2	5T#16	1/4" Dia.
RY1	Relay 1355/1365	
RFC4	7T#16	1/4" Dia.
D1,2,3	IN4003 Diodes	
C19,20		Feed Thru Allen Bradley
F1	Fuse	15A
R1	15 OHM	1 Watt

### **INSTALLATION INSTRUCTIONS:**

Connect the positive supply voltage to the red fused lead Connect the gnd lead to the negative or ground side of the power source Number 12 AWG wire or larger is recommended if the supply leads need to be lengthened Connect the amplifier between the transmitter or transceiver and the antenna RG-8A/U or equivalent coax is recommended for the connection between the amplifier and the antenna The amplifier may be mounted in any position

### **INSTALLATION HINTS:**

- 1 Check all coax cables for proper impedance (50 ohms) and freedom from shorts and/or opens
- 2 Although the maximum input SWR to the amplifier is 1.4:1, some transceivers may still be unable to produce power into the amplifier If this occurs, try a different length of coax between the transceiver and the amplifier One half wave multiples is probably the best choice (Belden foam 8214 31.5 inches RG-8LJ 26.75 inches )
  - b High antenna SWR (Try adding another 1/4 wave to the feed line )
  - c RF getting back into the transceiver caused by close antenna proximity, poor mic shielding, etc
- 4 If the amplifier appears to produce low power out, check the following
  - a A watt meter between the amplifier and the transceiver will check the drive level
  - b Measure the voltage during amplifier operation as close to the amplifier as possible Voltage for spec output is 13.5 VDC
  - c Even the best watt meters have an accuracy tolerance and they can be fooled if harmonic or parasitic energy is present Check the power at least two positions in the input and output line of the amplifier, there should be no significant change in power
- 5 The amplifier when installed should draw no current (less than 10 MA)