

PRIDE DX-300 Service Manual



Amp Series
Copyright © 2004 CBTricks.com
Version. 1.0

Be sure to stop by the CBTricks web site and check it out.

<http://www.cbtricks.com/>

A WORD OF THANKS TO THE FOLLOWING PEOPLE FOR HELPING WITH THIS MANUAL.

Chris Reifsteck (Nomad Radio) , Joe Piatt, and N-Channel.

Safety Instructions



READ FIRST BEFORE SERVICING THIS AMPLIFIER



Lethally high voltages are present inside the amplifier unit. Never remove either top or bottom cover when power line is connected. DO NOT attempt to operate unit when covers are removed:

- 1) Lethal voltages would be open to contact.
- 2) Protective interlock on top cover will short circuit the high voltage power supply; attempting to operate under these conditions can cause damage to power supply, amplifier tube, or both.
- 3) Attempting to operate the unit with bottom cover removed causes loss of air pressure to the tube, and can cause rapid failure of the tube.
- 4) Attempting to operate the unit with top cover removed (with the interlock blocked) may make the amplifier erratic in tuning and performance due to the high level of R.F. on the top chassis coupling to the coaxial input cable at the rear of the chassis. If repairs should be necessary, contact the factory, or a repair facility with proper equipment and technical experience for the servicing of high power amplifiers.

If covers need be removed, allow two minutes after turning the unit off and unplugging the line cord before removing covers.

Disclaimer: Although the greatest care has been taken while compiling these documents, we cannot guarantee that the information is 100% correct with that said we do feel that this is the most accurate information out there. The publisher assumes no liability for damages resulting from errors or omissions, or the violation of any law from use of this information. This also covers unsuccessful attempts to repair the equipment covered in this manual.

The service and modification information shown here are provided for properly licensed operators only!

The user is solely responsible for making sure that any modifications made to the unit must meet all Federal and State Regulations for the Country of use! Liability of damages to any equipment is the sole responsibility of the user!
Modifications are provided for information / educational purposes only!

Copyright © 2004 CBTricks.com / Bennie Bolin

All rights reserved. No part of this publication may be reproduced, stored in a retrieval system or transmitted in any form or by any means, electronic, mechanical, photocopying, or otherwise, without the prior written permission of the copyright holder (CBTricks.com).
All logos and Brand Names are the property of their respective owners.

<http://www.cbtricks.com/>

	PAGE
CHAPTER 1 Introduction	
1.0 Introduction:	1
1.1 Specifications:	1
CHAPTER 2 Operation	
2.0 Installation:	2
2.1 Operation:	3
CHAPTER 3 Circuit Description:	
3.0 Introduction:	5
3.1 High Voltage Supply:	5
3.2 Screen and Bias Supplies:	6
3.3 Low Voltage Supply:	6
3.4 R.F. Input and Control:	7
3.5 Safety Interlock:	9
3.6 Wattmeter:	9
CHAPTER 4 Maintenance	
4.0 Plate Current Measurement:	10
4.1 Bias Voltage Adjustment:	11
4.2 Wattmeter Calibration:	12
4.3 Input SWR Adjustment:	12
4.4 Voltage Checks:	13
4.5 Preventive Maintenance:	13
4.6 Tube Replacement:	14
CHAPTER 5 PCB Layouts	
5.0 Low Voltage Supply PCB:	15
5.1 High Voltage Supply PCB (Board #1):	16
5.2 High Voltage Supply PCB (Board #2):	17
5.3 Wattmeter PCB:	18
5.4 RF Input and Control PCB:	19
5.5 Safety Interlock PCB:	20
5.6 PCB Trace Layouts:	21
PCB Trace Layouts (Cont.):	22
5.7 Chassis Layouts Front and Rear:	23
5.8 Chassis Layouts Top and Bottom:	24
CHAPTER 6 Parts Lists	
6.1 High Voltage Power Supply PCB #1:	25
6.2 High Voltage Power Supply PCB #2:	26
6.3 Safety Interlock PCB:	26
6.4 Low Voltage Power Supply PCB:	27
6.5 RF Input and Control PCB:	28
6.6 Wattmeter PCB:	29
6.7 Chassis:	29
Chassis (cont.):	30

CHAPTER 7 Circuit Modifications

7.0	Introduction:	31
7.1	Screen LED Modification:	31
7.2	Screen Supply Modification:	31
7.3	Tube Oscillation:	31
7.4	Wattmeter PCB Modification:	31
7.5	Bias Circuit Modification Version 1:	32
7.6	Bias Circuit Modification Version 2:	32

CHAPTER 8 Component Information

8.0	Introduction:	33
8.1	Antenna Change Over and Preamp Relay Information:	33
8.2	Band Switch:	33
8.3	Input Coil Detail:	33
8.4	Z1 Detail:	33
8.5	Z2 Detail:	33
8.6	Blower Detail:	34
8.7	Part Suppliers:	34
	Nomad Radio Replacement HV Power Supply Kit Information	35

CHAPTER 9 Schematics

9.0	Introduction:	36
	Main Schematic:	37
	Power Supplies:	38
	RF Section:	39
	Inter-Connection Diagram:	40

1.0 INTRODUCTION:

In putting together this manual I started with the Pride DX300 factory manual added information that was missing and in error, put together new updated schematics and PCB layouts.

The Pride DX-300 is a high frequency linear amplifier covering the Amateur bands from 3.5 to 30 MHz. Pride Electronics in San Diego CA was a manufacturer of RF amplifiers and VFO's, as well as frequency counters. The products that Pride built were assembled by handicap people hence the slogan printed on the back of the amplifier "**Manufactured with Pride by the Handicap**". I think that most of the DX300's were built between 1977 and 1978. Some people say that Pride was in the business of selling CB amplifiers under the guise of amateur radio amps.

The Pride DX300 has no screen regulation, no feedback, and no screen or grid metering it was designed to provide a medium power amplifier with high power gain at LOW COST. It does have a receiver preamplifier, and automatic RF actuated switching. The amp has no mistuning protection but with care anyone should have not problems with tuning it using the TUNE mode.

1.1 SPECIFICATIONS:**Power Ratings:**

Mode	Drive	Power
SSB	15 watts peak.	1000 watts PEP input 650 watts nominal peak output any band.
CW	10-12 watts.	750 watts input, 50% duty cycle, 500 watts nominal output any band
AM	4-6 watts.	500 watts input, 5-minute cycle, 300 watts nominal output any band.

Frequency Coverage:

3.5 to 4.0 MHz
7.0 to 7.3 MHz
14.0 to 14.35 MHz
21.0 to 21.45 MHz
28.0 to 29.70 MHz

Device Complement:

1 4CX250B ceramic/metal tetrode
1 2N2905 receiver preamp transistor
1 2N2905 RF switching transistor
24 1N4007 rectifier diodes
5 1N4001 rectifier diodes
3 1N914 small signal diodes

Metering Functions:

Meter reads RF power output.
Amplifier tube screen current is monitored by an LED indicator.
Receive amplifier and power amplifier status are also monitored by LED indicators.

Front Panel Functions:

Power On/Off switch
Receive preamp on/off switch
SSB delay on/off switch
Tune/Standby/Operate switch
Plate tuning control
Band selector switch
Plate Loading control

Rear panel Functions:

Bias adjustment pot, Metering Jack and Input / Output RF connections.

AC Power Requirements:

120VAC 60 Hz, 500watts average 1000watts absolute peak.

Dimensions:

12" wide x 9" high x 12" deep.

Weight:

29lbs.

2.0 INSTALLATION:

- 1) Select a location for your amplifier. RF amplifiers need ventilation, so choose a location that will not restrict the air flow around the amp and where it won't get water, coffee, or soft drinks spilled on or in it.
- 2) Connect a short length of coaxial cable from the exciter to the amplifier input connector. RG58/U or RG8/U may be used and a PL 259 connector is required at the amplifier end of the cable. This cable should be as short as is practical, preferable less than five feet.
- 3) Connect antenna or suitable high power dummy load to the output connector of the amplifier using RG8/U coax. The smaller RG58/U coax may be used with matched antenna systems (better than 1.5 to 1 SWR) but will have somewhat higher loss. The amplifier will match most loads from 25 to 100ohm.
- 4) Exciter power levels above 12 watts PEP or 5 watts carrier level should be avoided as over drive of the amplifier will occur.
- 5) The unit should be grounded for R.F. by attaching a ground strap of coaxial shield or 10-12 gauge wire to the ground post on the amplifier. This should be connected by a short run to a ground rod or cold water pipe. The idea is to have a short direct earth ground to keep the chassis at radio frequency ground. In many cases normal operation can be had without such a ground, but a good ground can help prevent television interference, and make tuning straightforward.
- 6) The A.C. line cord should be plugged into a three-wire outlet. The electrical circuit should be capable of handling a 10-ampere load.

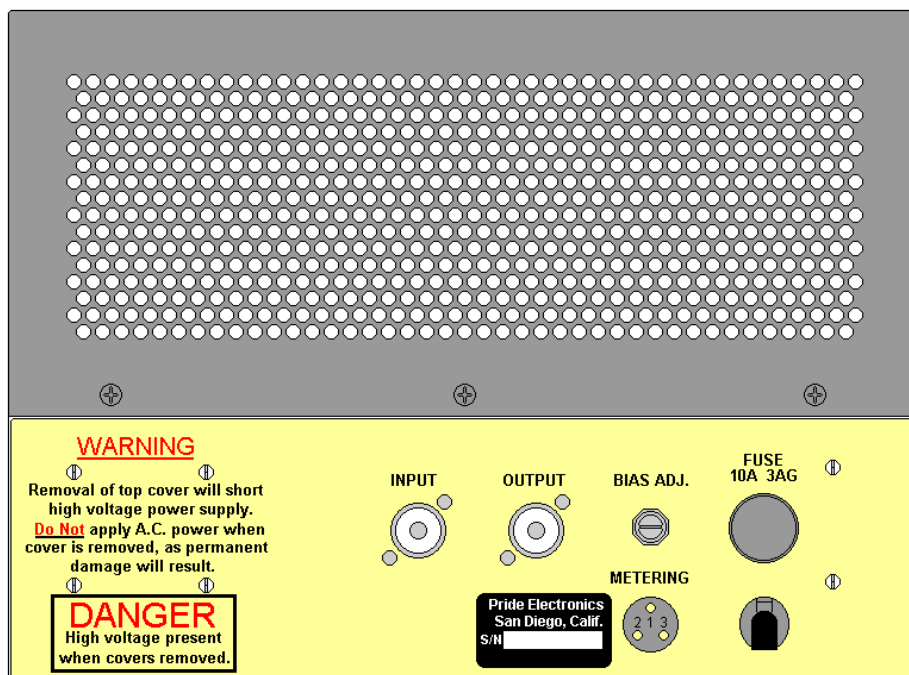

Figure 2-0 Rear Panel

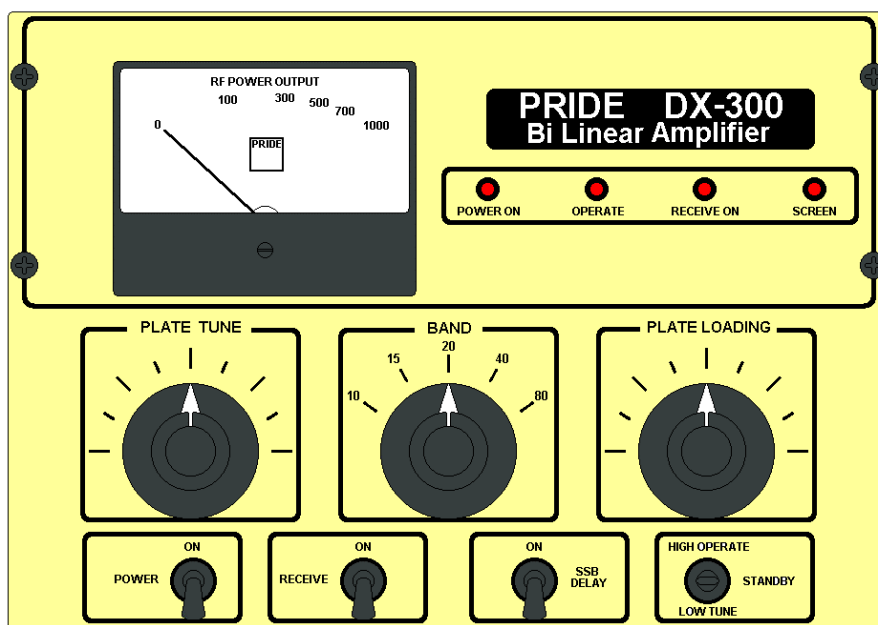

Figure 2-1 Front Panel

2.1 OPERATION:

- 1) Check to see that the **TUNE/STANDBY/OPERATE** switch is in the center or **STANDBY** position. Apply power to the unit by switching the **POWER** switch to the **ON** position. You will hear the cooling blower come up to speed. Wait 60 seconds for the tube to come up to operating temperature.
- 2) During the time that the amplifier is warming up or at any time that the **TUNE/STANDBY/OPERATE** switch is in the **STANDBY** position, the exciter may be operated normally "straight through" the amplifier.
- 3) Set the band switch to the same band as that the exciter is tuned to.
- 4) After warm up, place the **TUNE/STANDBY/OPERATE** switch into the **TUNE** position. The **OPERATE** indicator will light up, indicating that the unit is ready for operation. If the **RECEIVE** switch is on, the **RECEIVE** indicator will light also, indicating operation of the receive preamplifier.
- 5) Rotate the **PLATE LOADING** control to the nine o'clock (counter clockwise) position.
- 6) Apply several watts of drive from the exciter and quickly peak the **PLATE TUNE** control for maximum output as indicated on the front panel wattmeter. The **SCREEN** overload indicator may glow at this time, and will peak in brilliance at approximately the same place of tuning that maximum output occurs.
- 7) The **PLATE LOADING** control is then turned clockwise 1/2 division or so, and the **PLATE TUNING** control is peaked again for maximum output. The brilliance of the **SCREEN** indicator will peak again, but not quite as brightly as before. This process is continued until a further increase in the **PLATE LOADING** control will give no further increase in power output. This will normally result in approximately 100watts output for three to four watts of driving power.
- 8) Un-key the exciter, and place the **TUNE/STANDBY/OPERATE** switch in the **OPERATE** position. When the exciter is keyed again, the power output will be somewhat higher, and the **SCREEN** indicator may glow brightly again. Repeat the procedure as before, tuning the **PLATE LOADING** and **PLATE TUNING** controls alternately for maximum output. The **PLATE TUNING** control should always be the last control that is adjusted. Power output should be about 250watts for five watts drive at this point in the tune up procedure. When proper loading is accomplished, the **SCREEN** indicator should glow only dimly. The plate current, as read on an external meter, should be in the neighborhood of 200-250ma.

- 9) For SSB operation, drive power should now be gradually increased to 10 or 12 watts, and the unit peaked for maximum output. This can be done using the carrier insertion control on some exciters, or if this is not available, a steady tone may be applied to the microphone input. When maximum power has been achieved, operation consists of simply keying the microphone and speaking. The SSB delay switch should be in the on position, which will give the R.F. actuated relays a time delay, so that they won't chatter during transmission. During the SSB transmission, power output peaks will occur so rapidly that the output meter will not be able to follow the signal. If a monitor scope is available, it can be seen that the peak power is considerably better than the 400 watts or so that was obtained during tune up. The **SCREEN** indicator will flicker with the transmission level, and will reach full brilliance at high peak power levels. This is a faster indicator of peak drive conditions than is the power output meter.
- 10) For CW operation, tune up as in step nine above. Power output will be nominal 250 watts for 5 watts of driving power. The SSB delay switch may be left in the on position to prevent relay chatter during keying.
- 11) The 4CX-250B transmitting tube has been proven in commercial and military uses where long life and reliability are major factors. Although it is designed to work a little harder in amateur service, it will still be extremely reliable if a few common sense rules are applied.
- a) Make sure that the tube always receives a good airflow. Remember that a lot of watts are being packed into that rather small package, and that the only way to keep it cool is to get air through the tube fins. Do not block the top of the cabinet, or stack other equipment on the amplifier. Make sure that the rear of the chassis (where the blower gets its air) is open to cool room air. If the bottom cover of the unit has to be removed for service, see that it is replaced properly prior to plugging in the unit (for safety also). The bottom chassis must be pressurized in order to force air through the tube fins.
- b) Wait 60 seconds before applying drive to the tube. Allowing the tube to properly warm up will help you get the longest service from it.
- c) After a long period on the air, let the amplifier run in the **STANDBY** mode for a minute or so before turning off the power switch. This allows the blower to bring the tube down to a cooler temperature fairly rapidly.
- d) Avoid excessive R. F. drive to the amplifier.
- e) Use care in tuning most tube failures are the result of operator error, not equipment failure. These transmitting tubes are used for thousands of hours in commercial service, and similar results should be yours with reasonable precautions.

3.0 Circuit Description:

The DX-300 power amplifier uses a 4CX-250B Tetrode ceramic/metal construction, and utilizes forced air-cooling. It is in a grounded cathode, driven grid configuration that provides very high power gain, high peak power output, and excellent linearity and harmonic suppression. The use of tuned input circuits and broadband matching transformers permits low drive operation combined with additional rejection of exciter harmonics. Class AB operation of the tube permits high peak powers with low distortion products and harmonics. The amplifier has a tune function that restricts the power gain of the amplifier for easy, safe tune-ups. The use of a single tube in the design avoids the problem of matching tubes and it also simplifies repairs. RF actuated switching eliminates the need for switching contacts on the exciter, which are not found on some of the lower powered rigs on the market. An internal receiver preamp provides approximately 10db of gain on the higher frequencies.

Power supplies:

3.1 High Voltage Supply PCB:

The high voltage supply consists of the plate supply transformer located on the top of the chassis, and the two rectifier filter boards below chassis directly under the plate transformer. A bridge rectifier circuit is used, which allows good utilization of the transformer. Both circuit boards are the same, with the exception of the jumpers (JP1 and JP2), which determine whether the filter capacitors are on the high side of the series filter string, or on the low side. The low side board also contains two 6.8ohm, 2W metering resistors (R24, R25).

Each board contains one half of the bridge rectifier circuit, with appropriate jumpers between the boards. The filter string consists of six 100µf electrolytic capacitors (C11, C12, C13, C22, C23, C24) in series, with voltage equalizing resistors (R9, R10, R21, R22, R23) across each one. The time constant of the filter when no current is being drawn is approximately 20 seconds, so that supply will be largely discharged 60 seconds after turn off (ALWAYS CHECK). The high voltage developed by the supply is approximately 2200 VDC no load, and 1800 VDC at 500mA.

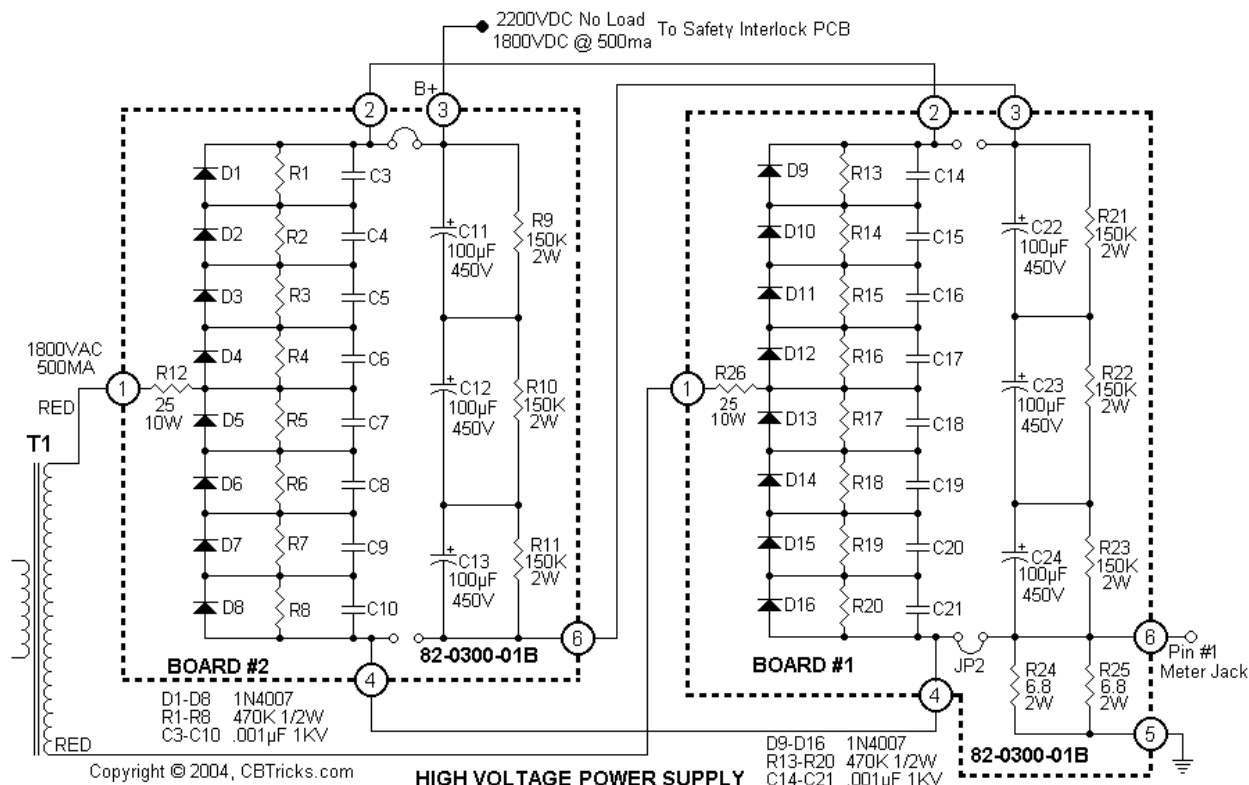

Figure 3-1 High Voltage Power Supply

3.2 Screen and Bias Supplies PCB:

The screen and bias supply is also bridge rectified, but with a center tapped transformer and filter string that allows a split output voltage. Approximately 700 VDC is developed across the two 40µf filter caps (C33, C34), but due to the circuit configuration this shows up as +350 and -350 VDC. The +350 VDC is fed through a 30ohm metering resistor (R36) to the screen current. The -350VDC is fed through two power resistors to provide source current for an 82 volt Zener diode (D25) that provides a stable bias supply voltage. This -82 volt supply is dropped in a voltage divider consisting of the back panel bias pot and two 3300ohm, 2W resistors (R40, R41) to provide an adjustable, stable bias source for the tube control grid.

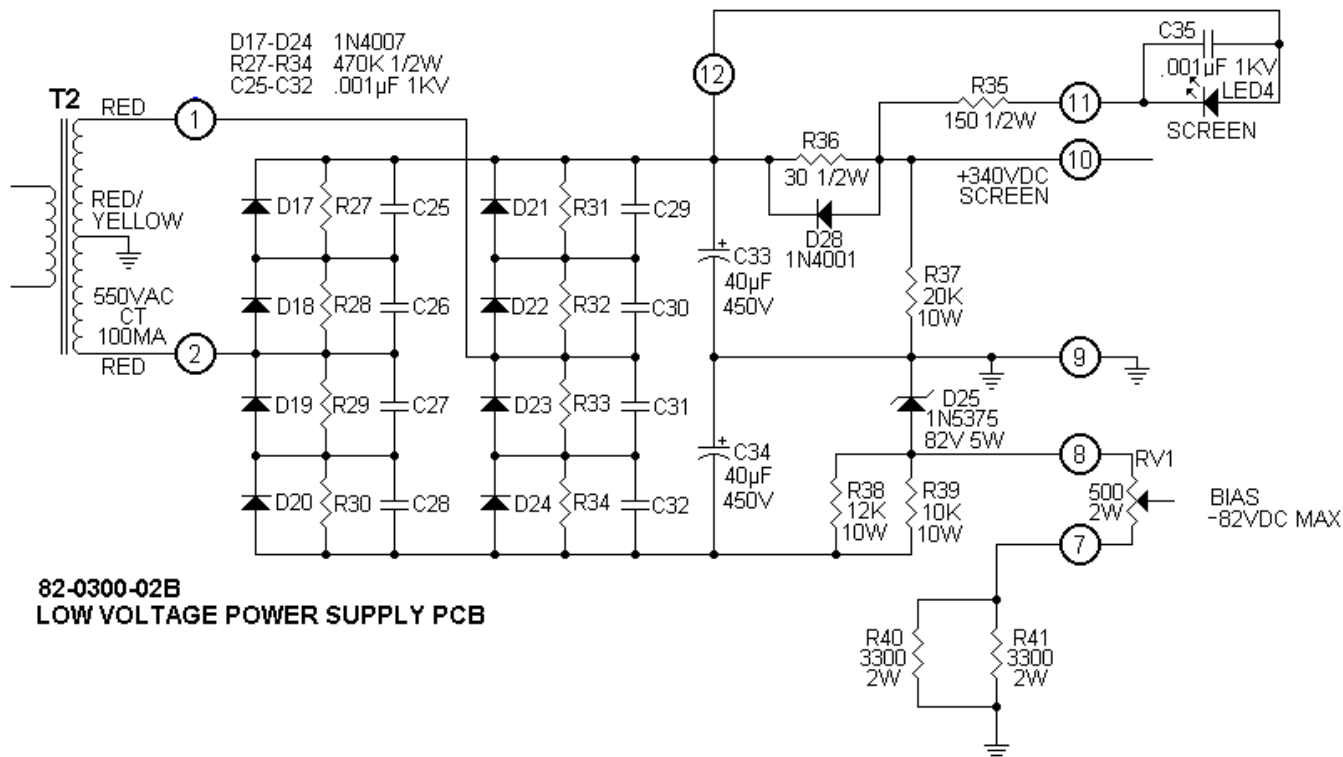

Figure 3-2 Screen and Bias Voltage Power Supply

3.3 Low Voltage Supply PCB:

This supply consists of a full wave voltage doubler, which is supplied from the 6.3volt filament winding on the smaller transformer. 12 to 15 VDC is developed for use of the receive preamp, relays and indicators.

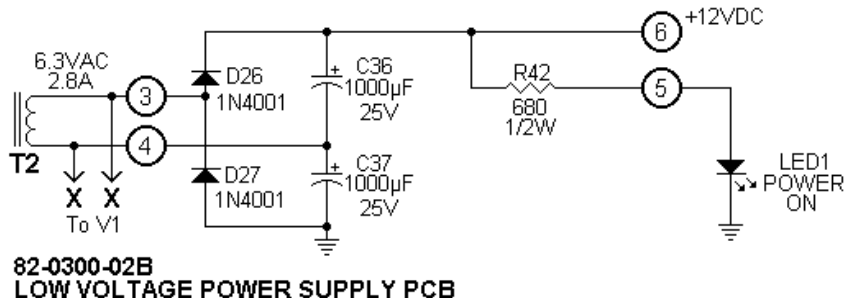

Figure 3-3 Low Voltage Power Supply

3.4 R.F. Input and Control Board:

This board is located under chassis near the tube socket, and is mounted horizontally. It contains the R.F. switching circuitry, input matching transformer and tuned toroid input coils, the receiver preamp, and some of the control circuitry.

Control

Drive power from the exciter is fed to one set of contacts on the (RL1) 4PDT relay and coupled also to a 2N2905 (Q1) relay-switching transistor. When the amplifier is in the standby mode, drive is fed through the relay to the output connector. In the operate or tune mode, drive is switched to the 9:1 input matching transformer (T3), which steps the impedance up from 50ohm to 450ohm to feed the input circuitry. The rear deck of the Band Switch selects a tuned circuit for the appropriate band. Two 1500ohm, 2W resistors (R44, R45) are in parallel with the resonant input circuit to provide proper loading and bandwidth. Adjustable bias voltage is fed to the grid through a 200uH choke (L14), an input toroid, and the parasitic choke (Z1) on the tube grid connection.

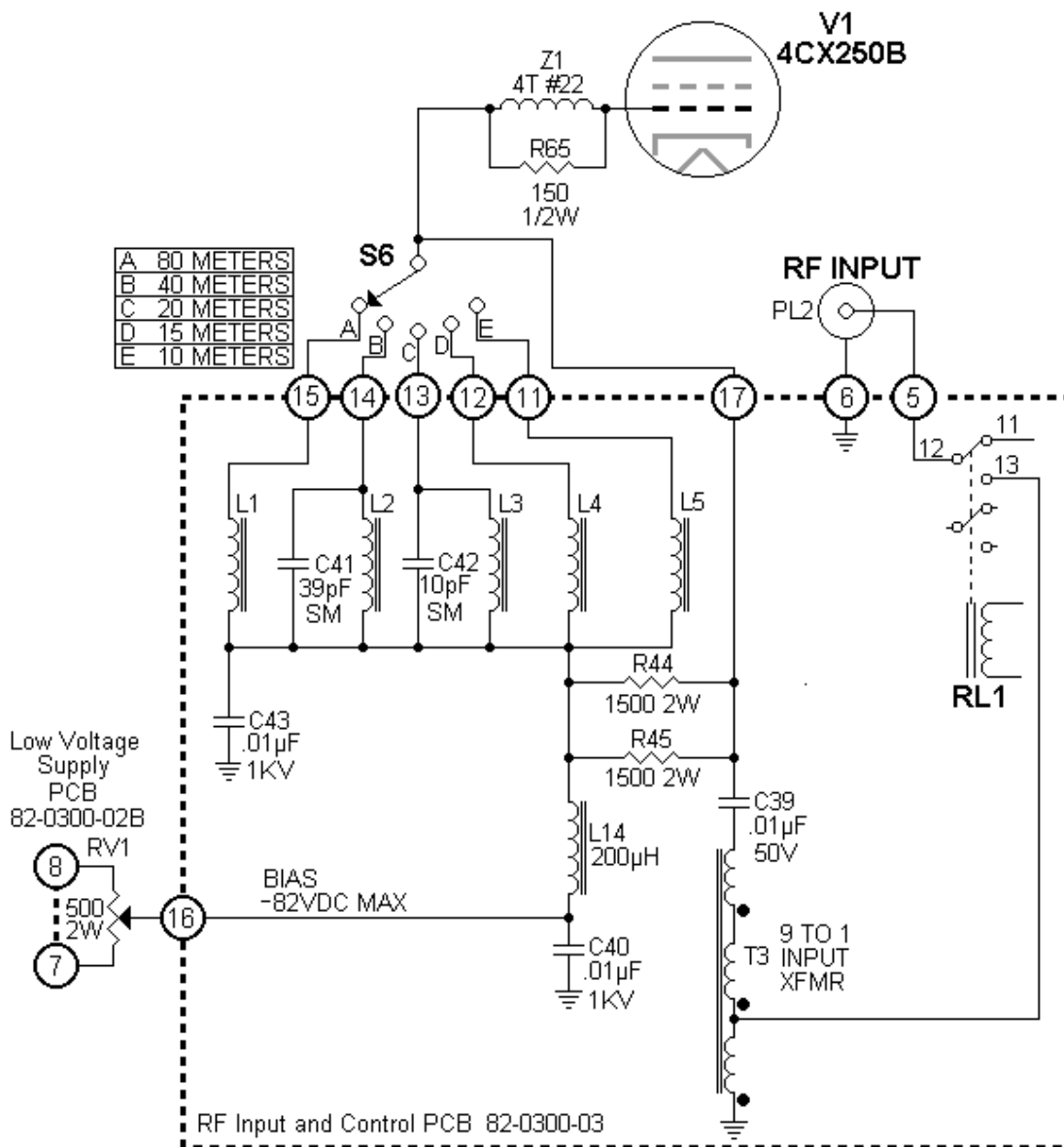

Figure 3-4 RF Input Circuit

Another set of contacts on the (RL1) 4PDT relay switches the cathode circuit of the tube to ground when the amplifier goes into the "on the air" condition. When not transmitting, two 18K, 2W resistors (R46, R47) provide a cathode blocking bias that prevents the tube from pulling current. The two 270ohm, 2W resistors (R48, R49) that are in series with the cathode line provide some additional bias during the TUNE mode, causing a loss in power gain and making it easy to tune up at lower power. These resistors are shorted out by a section of the TUNE/STANDBY/OPERATE switch when in the OPERATE mode.

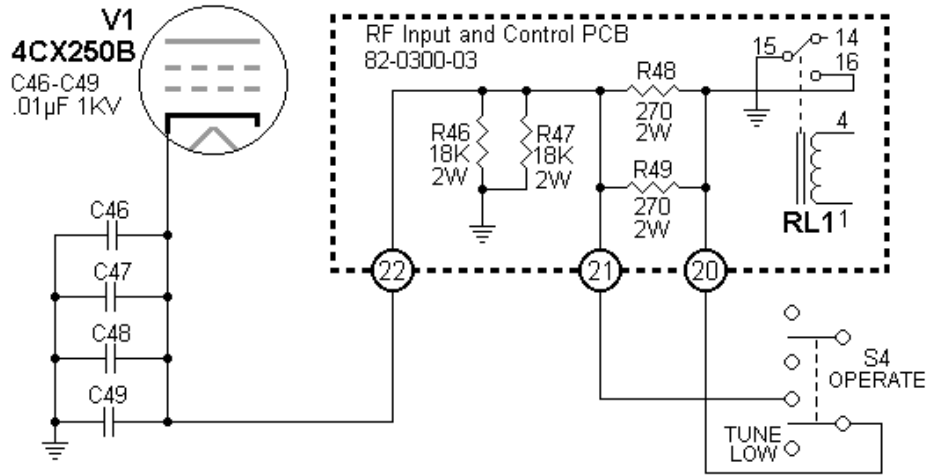

Figure 3-41 Cathode Circuit

The (RL2) DPDT relay on the main R.F. board is used solely for switching the receiver preamp in and out of the antenna circuit. It is controlled by both the RECEIVE switch on the front panel and the grounding contact on the (RL1) 4PDT relay.

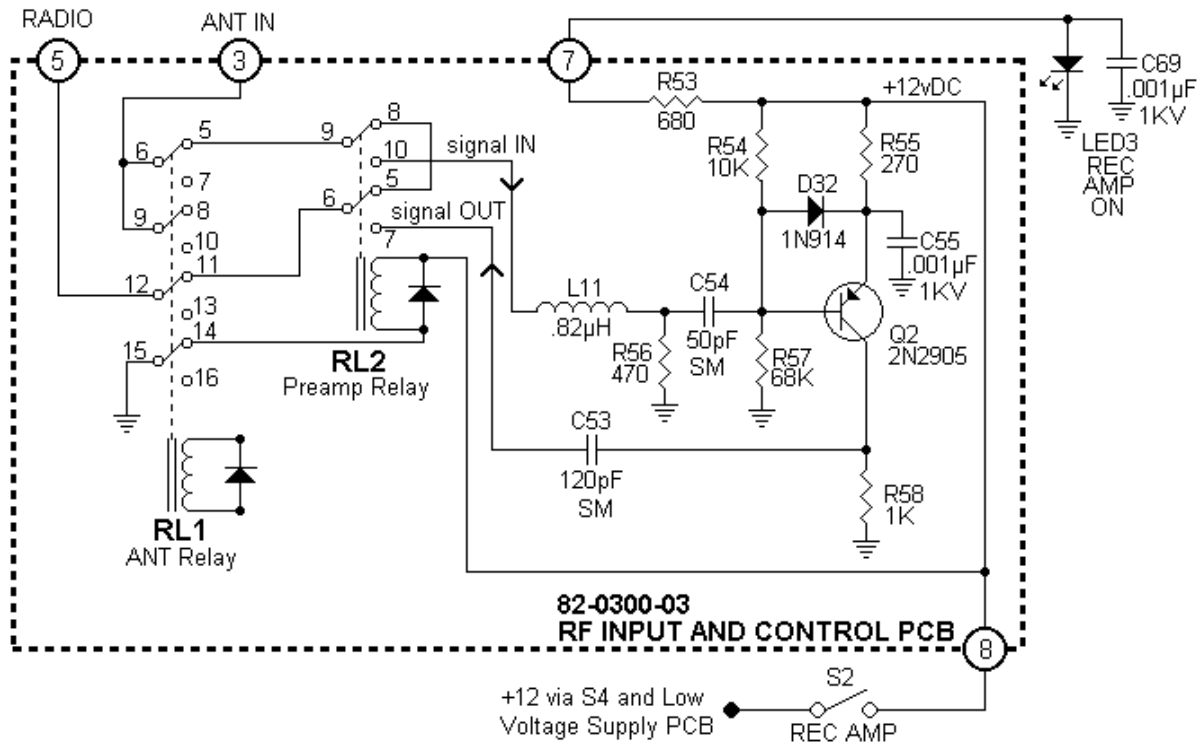

Figure 3-42 Receiver Preamp Circuit

3.5 Safety Interlock PCB

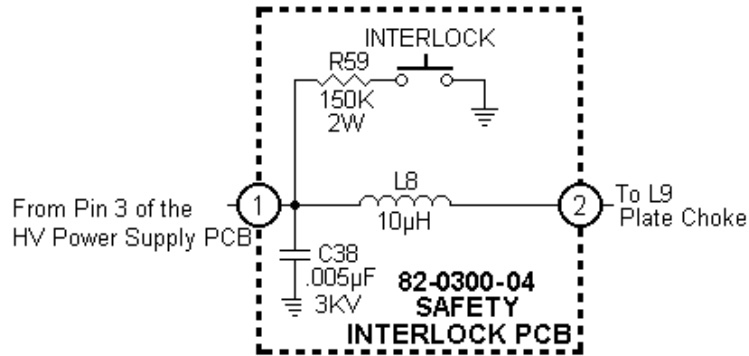

Figure 3-5 Safety Interlock Circuit

Never turn on the amp with cover off:
 The shorting safety switch will cause the high voltage to short out.
 If this happens it will usually takes out R59 or the bridge rectifier.

3.6 Wattmeter PCB:

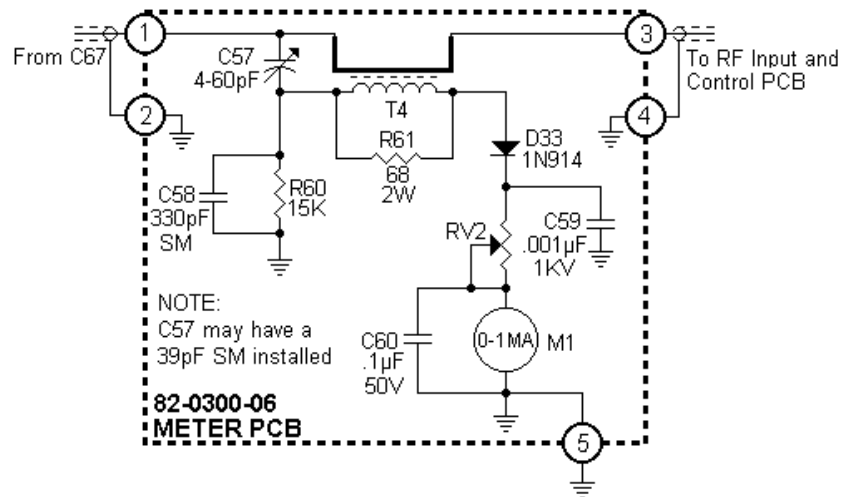

Figure 3-6 Wattmeter Circuit

Maintenance

The following information is presented so that the competent service technician should have no trouble in performing routine service on the Pride DX-300.

Lethally high voltages are present inside the amplifier unit. Never remove either top or bottom cover when power line is connected. **DO NOT** attempt to operate unit when covers are removed:

- 1) Lethal voltages would be open to contact.
- 2) Protective interlock on top cover will short circuit the high voltage power supply; attempting to operate under these conditions can cause damage to power supply, amplifier tube, or both.
- 3) Attempting to operate the unit with bottom cover removed causes loss of air pressure to the tube, and can cause rapid failure of the tube.
- 4) Attempting to operate the unit with top cover removed (with the interlock blocked) may make the amplifier erratic in tuning and performance due to the high level of R.F. on the top chassis coupling to the coaxial input cable at the rear of the chassis. If repairs should be necessary, contact the factory, or a repair facility with proper equipment and technical experience for the servicing of high power amplifiers.

If covers need be removed, allow two minutes after turning the unit off and unplugging the line cord before removing covers.

4.0 Plate current measurement:

Plate current can be monitored by means of an external meter plugged into the METERING jack on the back panel. The voltmeter should be connected as below:

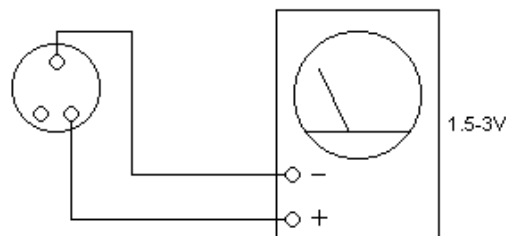

Figure 4-0 Meter Connection

The following chart converts voltage as read at the metering jack to actual plate current.

.17V = 50mA	1.02V = 300mA
.34V = 100mA	1.19V = 350mA
.51V = 150mA	1.36V = 400mA
.68V = 200mA	1.53V = 450mA
.85V = 250mA	1.70V = 500mA

4.1 Bias voltage adjustment:

The following adjustment is from the factory manual you may want to do it another way.

The bias voltage should rarely need attention. If, however, the tube is changed or the adjustment is otherwise disturbed, the following procedure should be adhered to.

1) Be sure the amplifier has been off for several minutes to allow enough time to discharge the power supplies. Remove the bottom cover.

2) Place a jumper wire or clip lead from point (A) on the main circuit board to ground. Refer to pictorial for specific placement of the jumper.

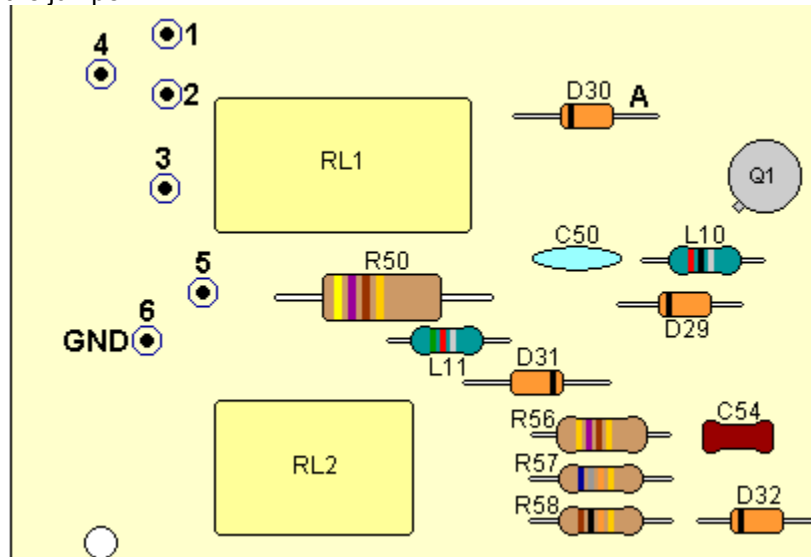

Figure 4-1 Jumper A

3) Replace bottom cover.

4) Place a 50ohm dummy load on the output connector of the amplifier.

5) Turn the unit on and allow it to warm for 60 seconds.

6) Place the TUNE/STANDBY/OPERATE switch into the OPERATE position and adjust bias control for a reading of 35mA or .12V as read at the metering jack.

7) Turn off unit and allow it to discharge for several minutes before restoring it to normal configuration.

This completes the bias adjustment.

4.2 Wattmeter Calibration:

The following adjustment is from the factory manual you may want to do it bypassing the safety interlock and adjust it with the top removed but use caution.

If adjustment becomes necessary, it should be performed only if the following equipment is available:

Exciter: 100 to 200watts output at 28 MHz

Dummy load: 50ohm with an accurately calibrated wattmeter.

Calibration procedure:

- 1) Remove the top cover after allowing several minutes for the unit to discharge to a safe level.
- 2) Disconnect the right hand (as viewed from the front of the unit) coax cable at the wattmeter board and attach a short length of RG58/U coax cable from the wattmeter board to the output of your exciter.
- 3) Disconnect the left hand coax cable and attach a short length of RG58/U from the wattmeter board to the input of the dummy load/wattmeter.
- 4) Apply power and adjust the exciter for an output of 100 to 200watts as read on the dummy load/wattmeter.
- 5) Set the potentiometer on the wattmeter board for the same reading.

This now completes the calibration of the wattmeter. Restore the unit to its original configuration.

4.3 Input SWR adjustment:

If the input SWR should require adjustment on any particular band, the following procedure should be used:

- 1) Remove the bottom cover after allowing sufficient time for the power supply to discharge to a safe level.
- 2) Apply +12 VDC to point (B) as identified on the pictorial of the main circuit board.

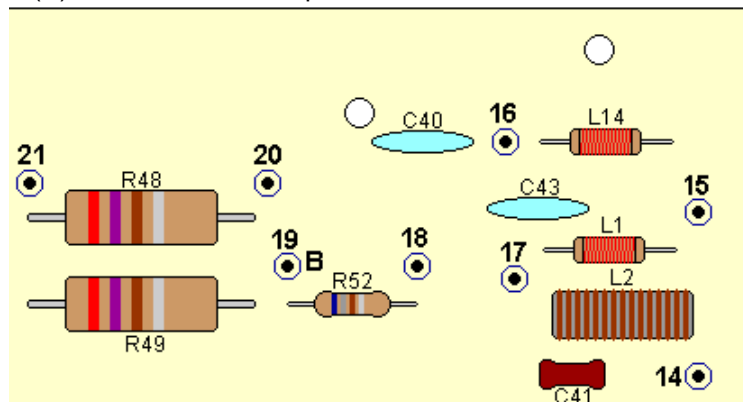

Figure 4-3 Jumper B

- 3) Place the TUNE/STANDBY/OPERATE switch into the operate position.
- 4) Apply approximately three watts of drive to the input of the amplifier (with band switch set to the appropriate band).
- 5) Spread or compress the turns of the toroid for the band in use to obtain the lowest SWR reading possible.
- 6) Restore the unit to its original configuration.

4.4 Voltage Checks

As the voltages present on the DX-300 chassis are potentially lethal, the procedure below must be followed when checking voltages.

- 1) Make sure that the unit is unplugged and has been off for several minutes to allow all voltages to bleed to zero.
- 2) Remove the top cover. Doing so will engage the safety interlock so never apply A.C. power when this cover is removed.
- 3) Loosen and remove the anode clamp from the 4CX-250B tube (**V1**). Remove the tube, the ceramic chimney, and the anode clamp from the chassis. Make sure the parasitic suppressor (**Z2**) is suspended away from any chassis parts.
- 4) Replace the top cover on the amplifier.
- 5) Lay the amplifier on its side or top and remove the bottom cover. Remember the tube must be removed or it will be damaged by the loss of cooling air when the unit is powered without the bottom cover.
- 6) Apply A.C. power to the unit. **WARNING:** Extreme caution must be used when working with voltages of this level. Always be cautious and alert while working on the live chassis.
- 7) Refer to the individual circuit board pictorials for voltage readings and locations. Voltages on the tube socket are as follows:

Pin 1	+350 VDC, \pm 10%
Pins 3 and 7	6.3VAC, \pm 10%
Grid Connection	-82 to -64 VDC, depending on the setting of bias control and mods installed.

Caution: When measuring the B+ supply (+2200 VDC), use only a meter, which is designed to measure 2kv plus safety during operation at high voltage levels.

- 8) Restore the unit to its original condition.

4.5 Preventive Maintenance

There are four circuit boards in the bottom compartment have all the wires attached to them with small spring-metal socket contacts. Pull each of the socket contacts one at a time. If any of them that feel loose when you pull on it should be GENTLY squeezed with a small pair of pliers so that it has some friction when you push it back onto its circuit-board pin. Check for burnt components on each of the circuit boards replace as needed and look for reason for failure.

Important

When you put the bottom cover back on check the seal and be sure that you put all the screws in. Also be sure that the 3 screws on the back of the top cover are installed.

Now take a close look at that big copper hair-pin (**Z2**) that attaches to the tube clamp topside. If the resistors look like toast, new resistors should be installed before you try to run it.

If the resistors look okay, and it has all 3 of them, leave it alone. If you replace them, we recommend using a 5-Watt rated 100-ohm carbon-film or metal-film resistor. They will withstand more abuse than the original 2 Watt-rated parts. DO NOT use wire wound resistors. Period. Both Mouser Electronics and Westgate Labs sell this resistor.

Check the main fuse (**F1**) in the back, and check the rating printed on it. The correct size is 10 Amp, 125 Volt or 250 Volt. A 32-Volt fuse is NOT the right type for this amplifier.

4.6 Tube Replacement:

If a tube failure does occur, a likely reason for this would be a loss of one or more of the required operating voltages at the tube socket. Thus, before a tube is replaced, the voltage measurement procedure should be followed to determine if further repairs are necessary. If all required voltages are present, the tube can then be replaced safely.

The 4CX250R is a 'ruggedized' 4CX250B with a better cathode and more gain. It is pin and heater compatible with the 250B. The Eimac catalogue says: "The 4CX250R/7580W will replace the 4CX250B in equipment where the range of bias adjustment will tolerate this higher perveance tube and where the tuning range can compensate for the small differences in input and output capacitances. It means you may need a bit more negative G1 bias to set the required standing current (100mA per tube).

Brand of tube types that work in the DX300

Eimac	Best
Taylor	Very Good
Svetlanta (Russian)	Very Good
Edcom	Not Good

Tubes that will work
4CX250B, 4CX250R,

Have heard of people using a 4CX350B but I haven't tested that.



4CX250B/7203	4CX250R/7580W
Characteristics	Characteristics
Plate Dissipation (Max.) 250 Watts	Plate Dissipation (Max.) 250 Watts
Screen Dissipation (Max.) 12 Watts	Screen Dissipation (Max.) 12 Watts
Grid Dissipation (Max.) 2 Watts	Grid Dissipation (Max.) 2 Watts
Frequency for Max. rating (CW) 500 MHz	Frequency for Max. rating (CW) 500 MHz
Amplification Factor 5	Amplification Factor 5
Filament/Cathode Oxide Coated	Filament/Cathode Oxide Coated
Voltage 6.0 Volts	Voltage 6.0 Volts
Current 2.6 Amps	Current 2.6 Amps
Capacitance Grounded Cathode	Capacitance Grounded Cathode
Input 4.5 pf	Input 4.8 pf
Output .04 pf	Output .04 pf
Feedthrough 15.7 pf	Feedthrough 17.5 pf
Capacitance Grounded Grid	Capacitance Grounded Grid
Input 4.5 pf	Input --- pf
Output .01 pf	Output --- pf
Feedthrough 13.0 pf	Feedthrough --- pf
Cooling Forced Air	Cooling Forced Air
Base 9 Pin Special	Base 9 Pin Special
Air Socket SK-600A	Air Socket SK-600A
Air Chimney SK-606	Air Chimney SK-606
Boiler ---	Boiler ---
Length 2.46 in; 62.50 mm	Length 2.46 in; 62.50 mm
Diameter 1.64 in; 41.70 mm	Diameter 1.64 in; 41.70 mm
Weight 4 oz; 113 gm	Weight 4 oz; 113 gm

5.0 Low Voltage Supply PCB:

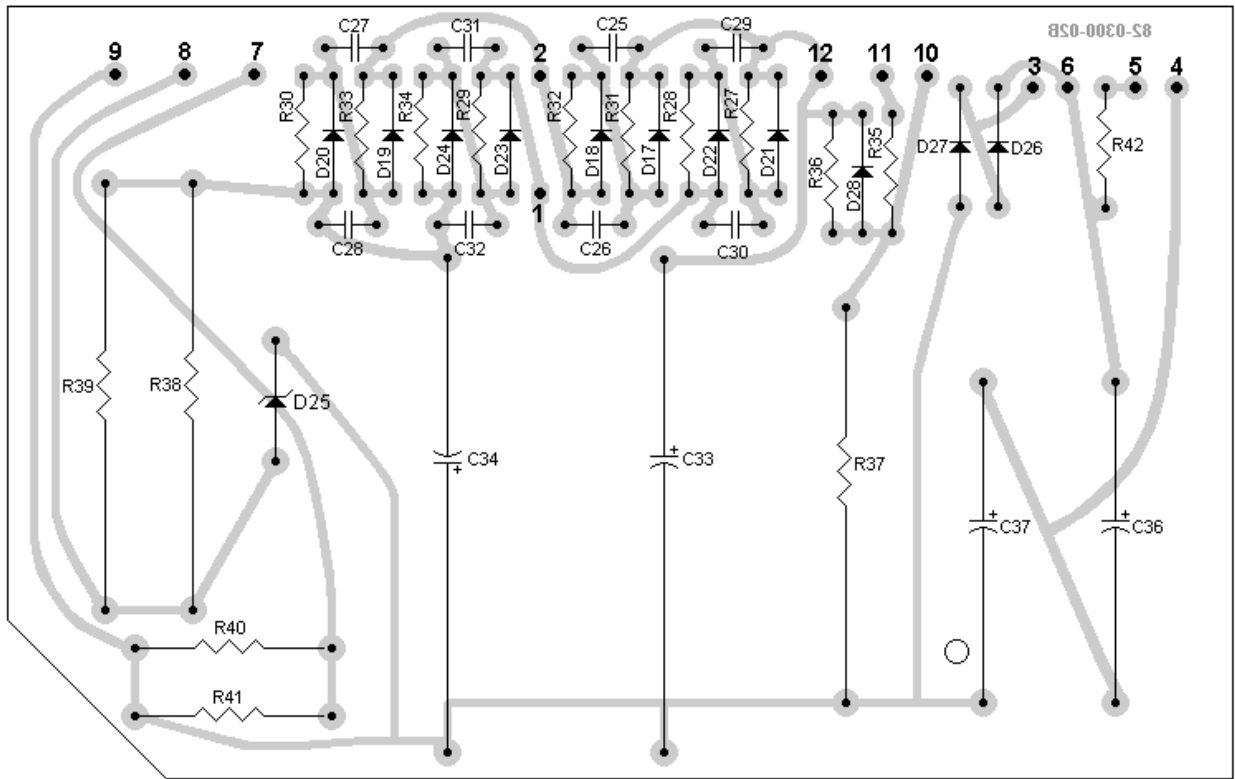
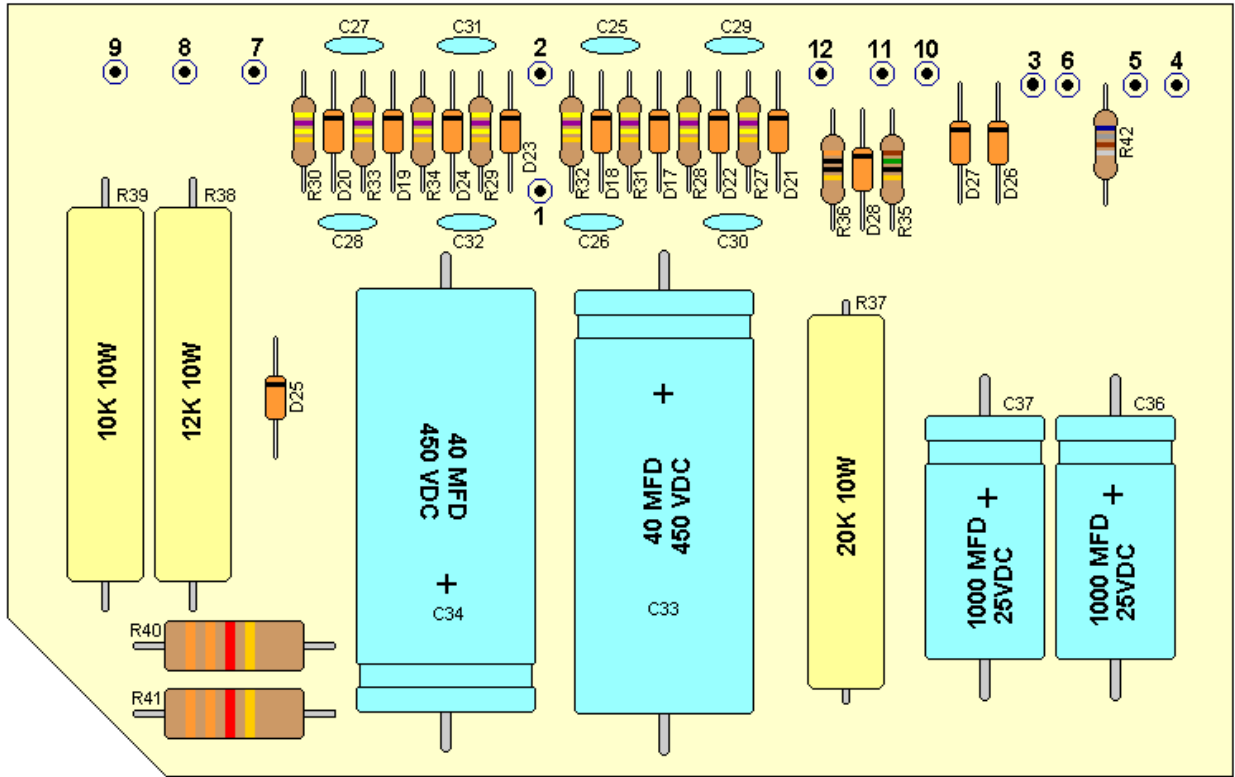

PRIDE DX300 Bi Linear Amplifier
LOW Voltage Power Supply PCB
82-0300-02B

Copyright © 2004, CBTricks.com All Rights Reserved
Rev.# 1.0

5.1 High Voltage Supply PCB (Board #1):

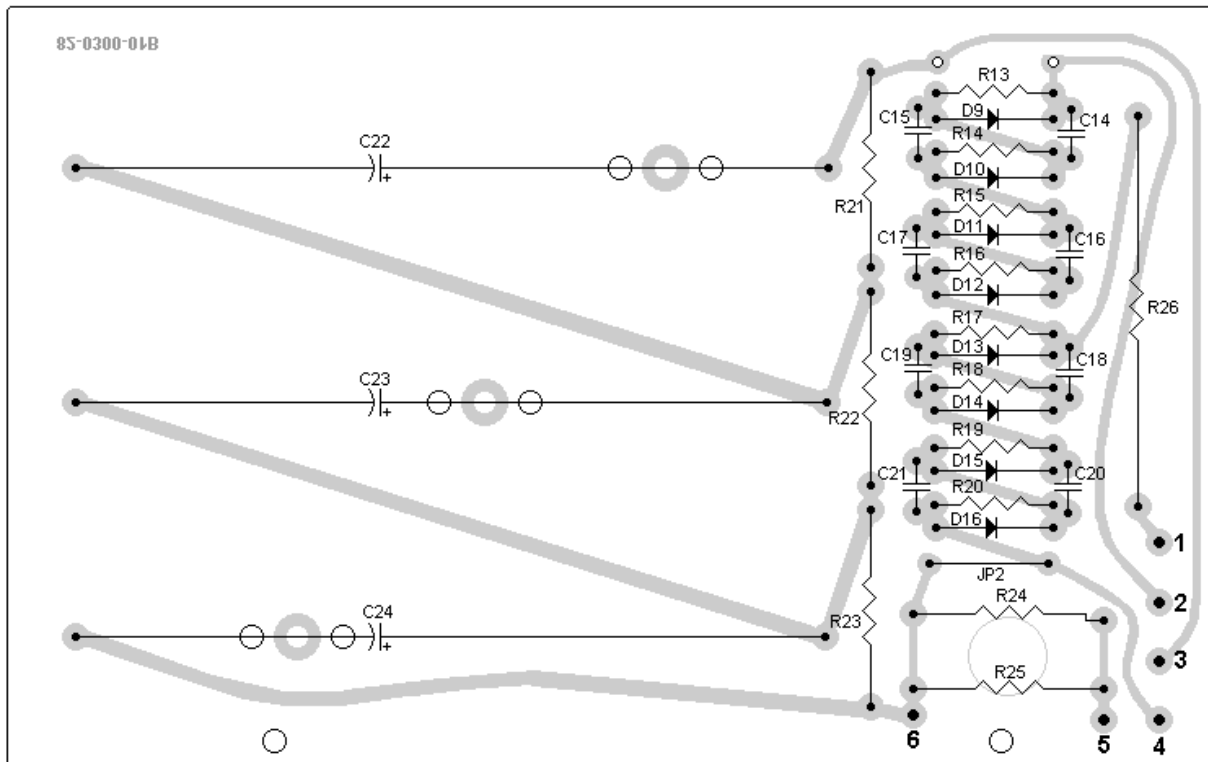
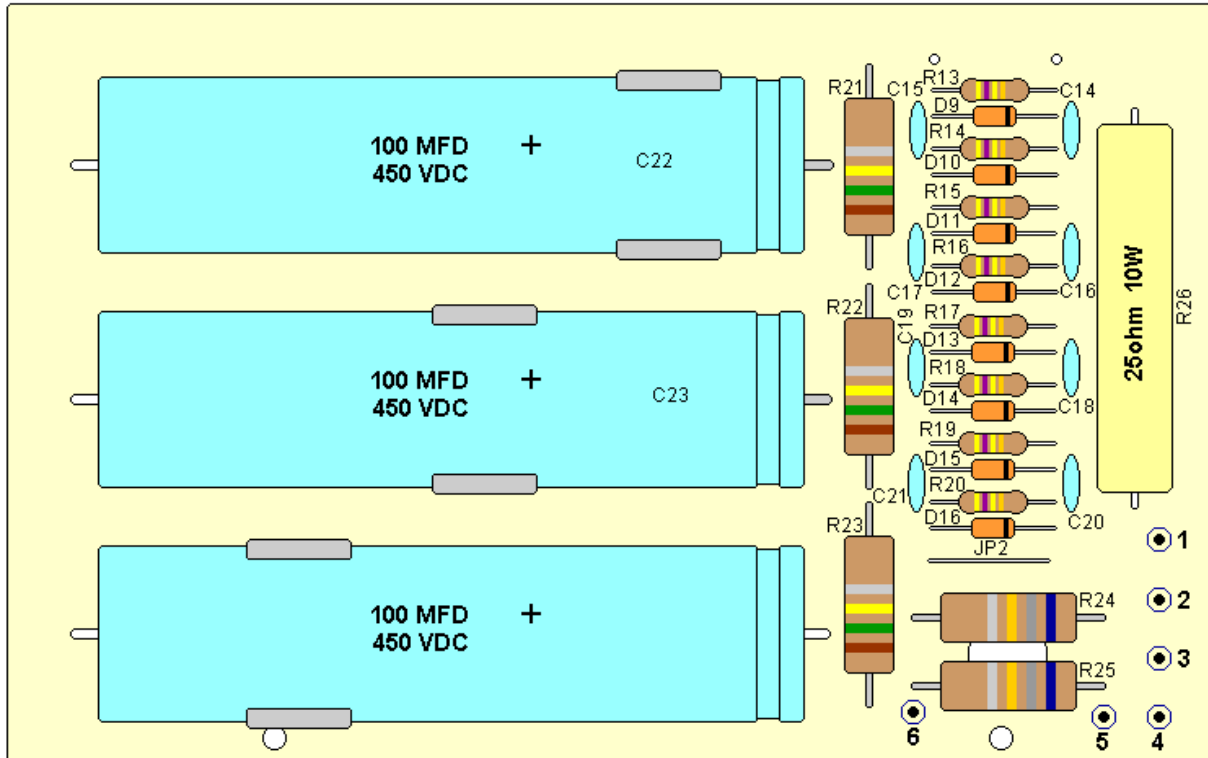

PRIDE DX300 Bi Linear Amplifier
HIGH Voltage Power Supply PCB (Board #1)
82-0300-01B
 Copyright © 2004, CBTricks.com All Rights Reserved
 Rev.# 1.0

5.2 High Voltage Supply PCB (Board #2):

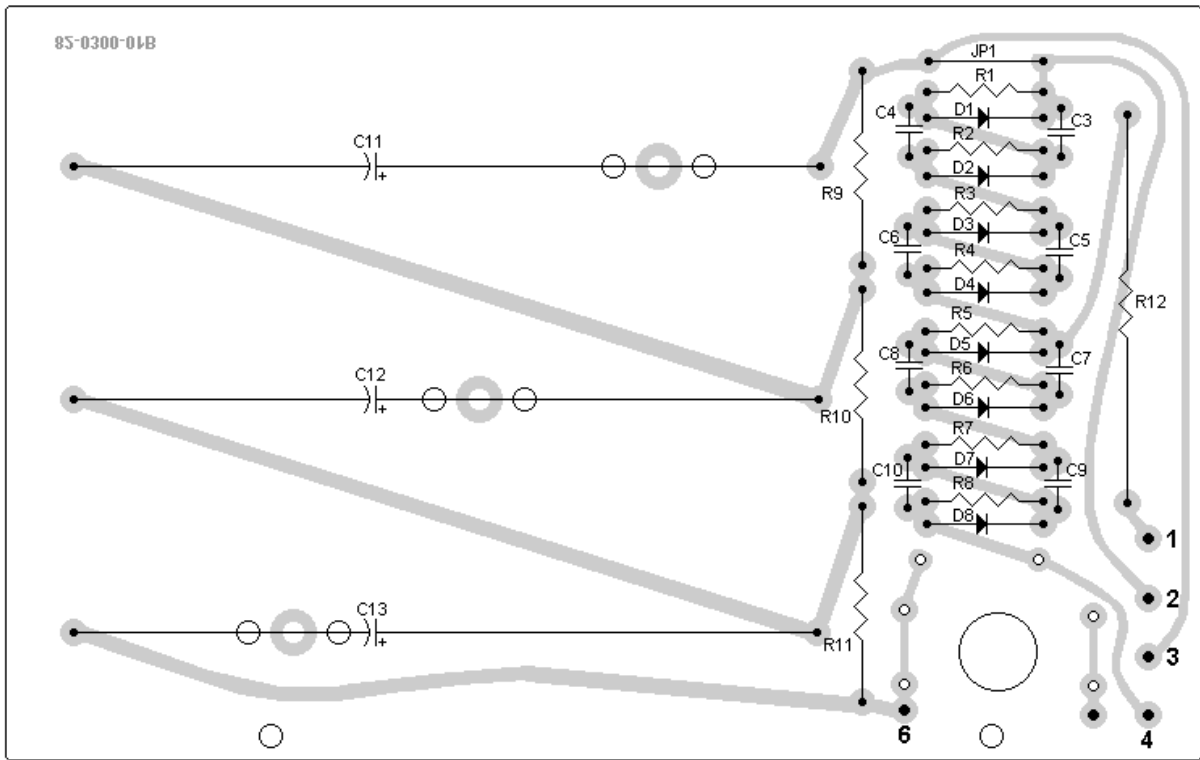
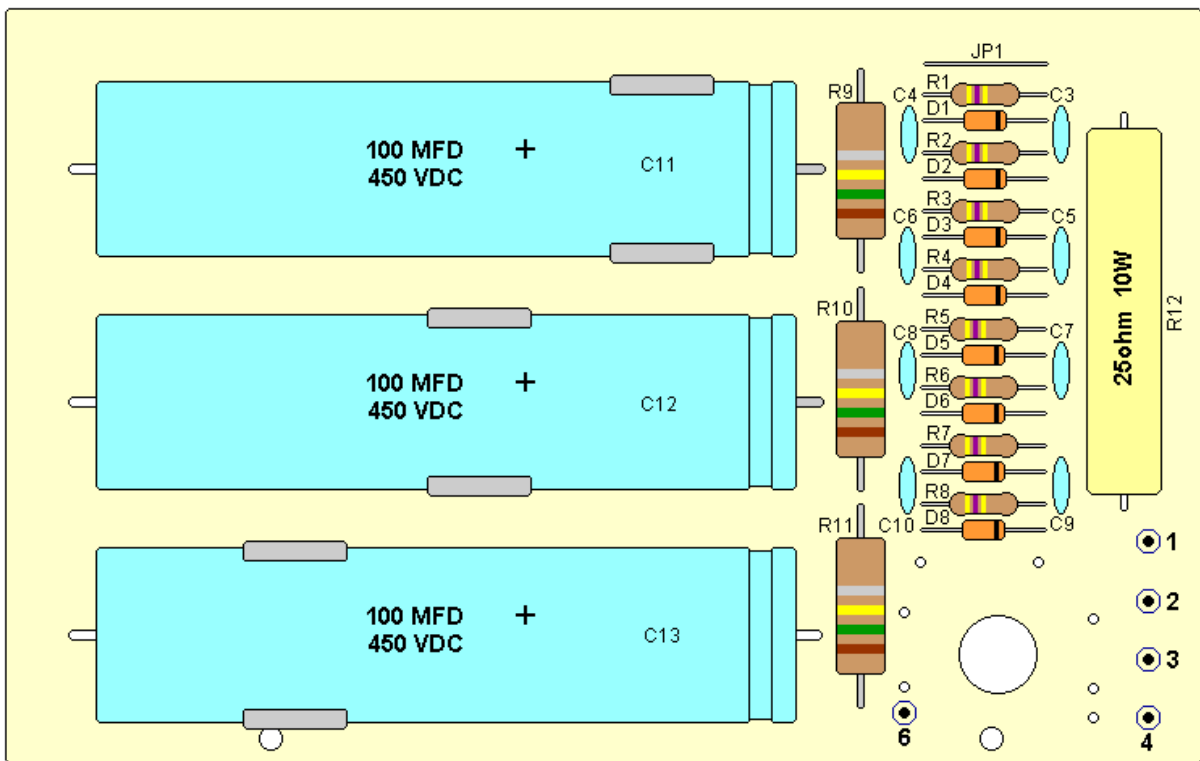

PRIDE DX300 Bi Linear Amplifier
HIGH Voltage Power Supply PCB (Board #2)
82-0300-01B
 Copyright © 2004, CBTricks.com All Rights Reserved
 Rev.# 1.0

5.3 Wattmeter PCB:

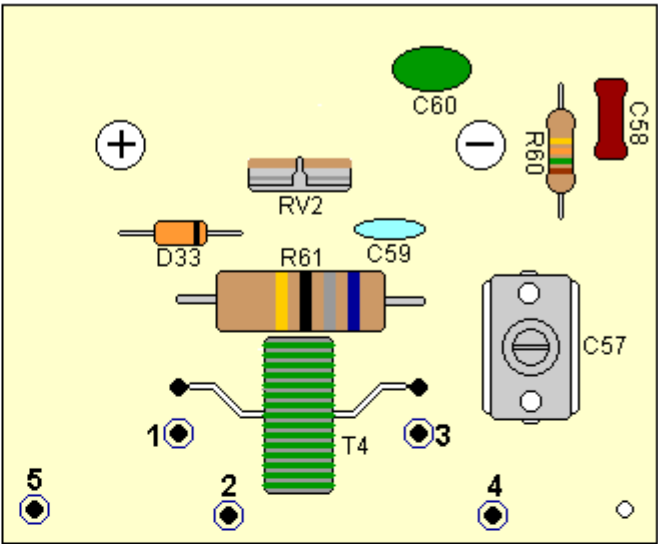
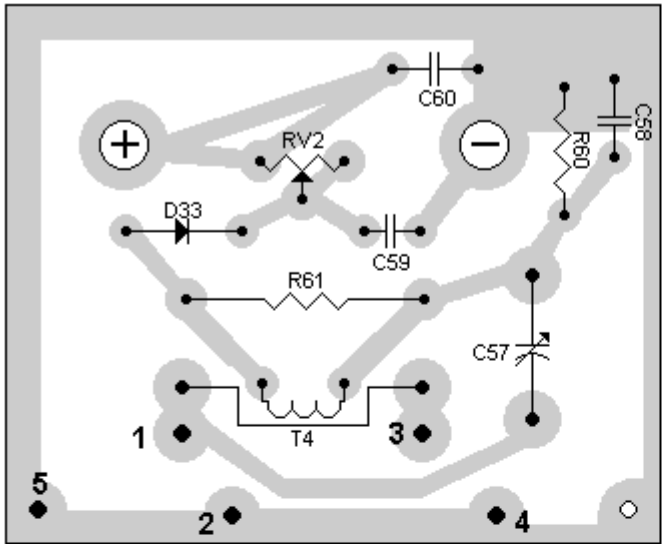

Component Side View

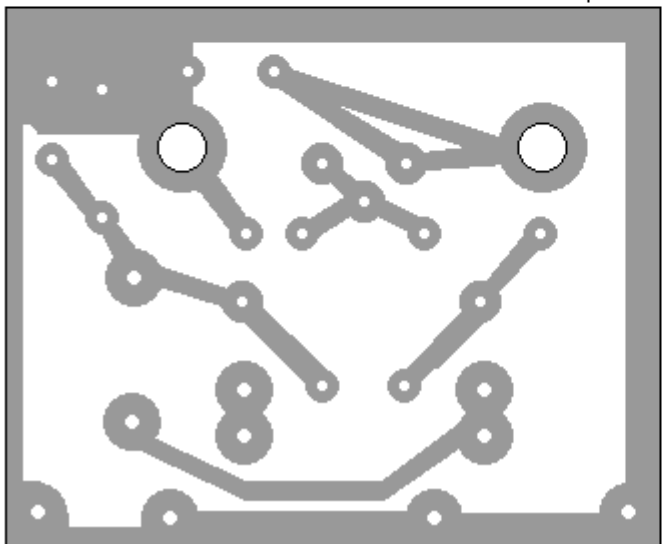

Copper Side View

**PRIDE DX300 Bi Linear Amplifier
Meter PCB
82-0300-02B**
Copyright © 2004, CBTricks.com All Rights Reserved
Rev.# 1.1

5.4 RF Input and Control PCB:

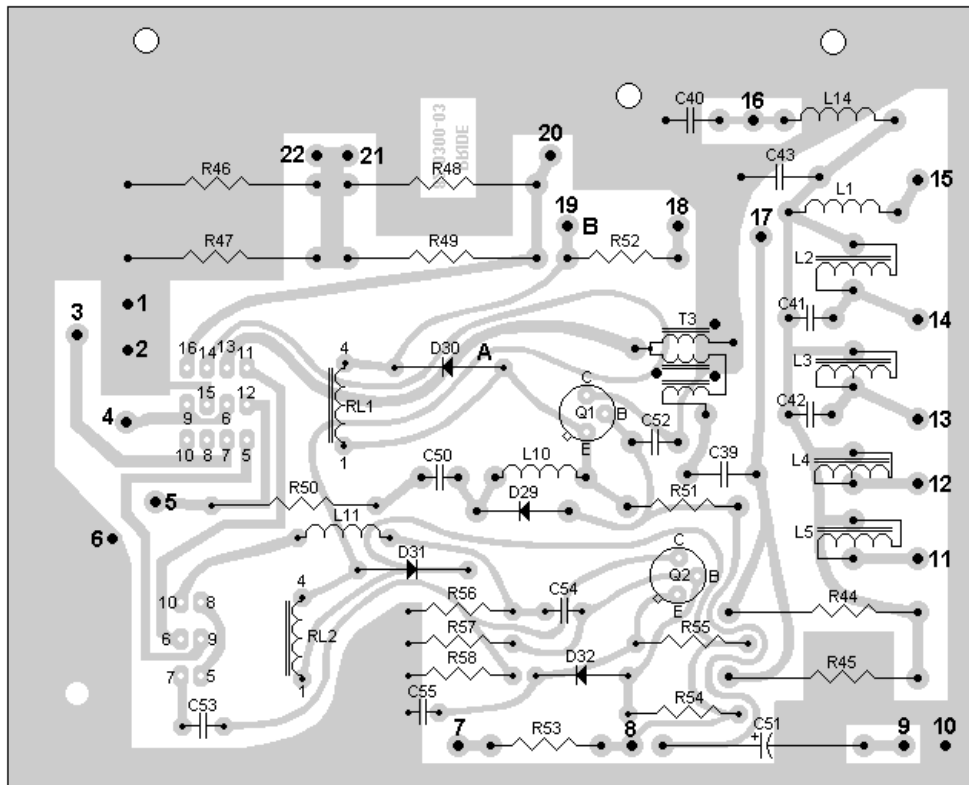
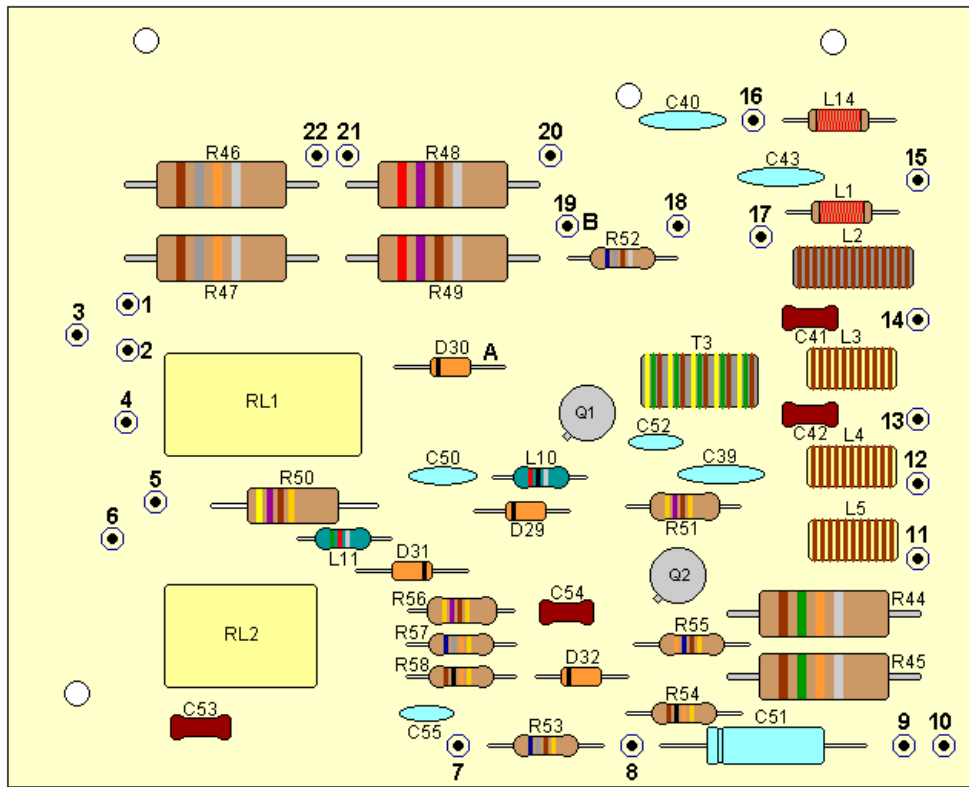

PRIDE DX300 Bi Linear Amplifier
RF Relay and Control PCB 82-0300-03
Copyright © 2004, CBTricks.com All Rights Reserved
Rev.# 1.2

5.5 Safety Interlock PCB:

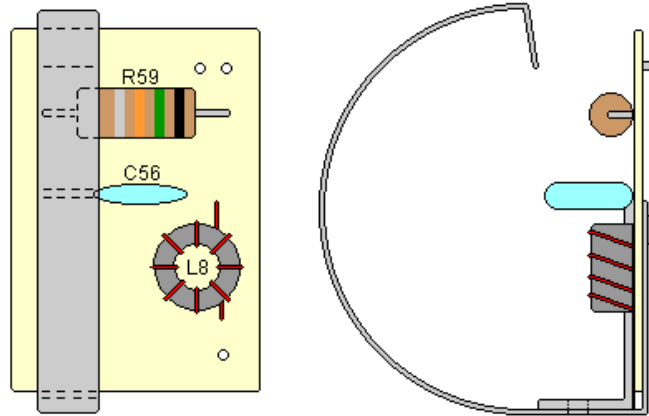

PRIDE DX300 Bi Linear Amplifier
HV Safety Interlock PCB 82-0300-04
Copyright © 2004, CBTricks.com All Rights Reserved
Rev.# 1.0

5.6 PCB Trace Layouts:

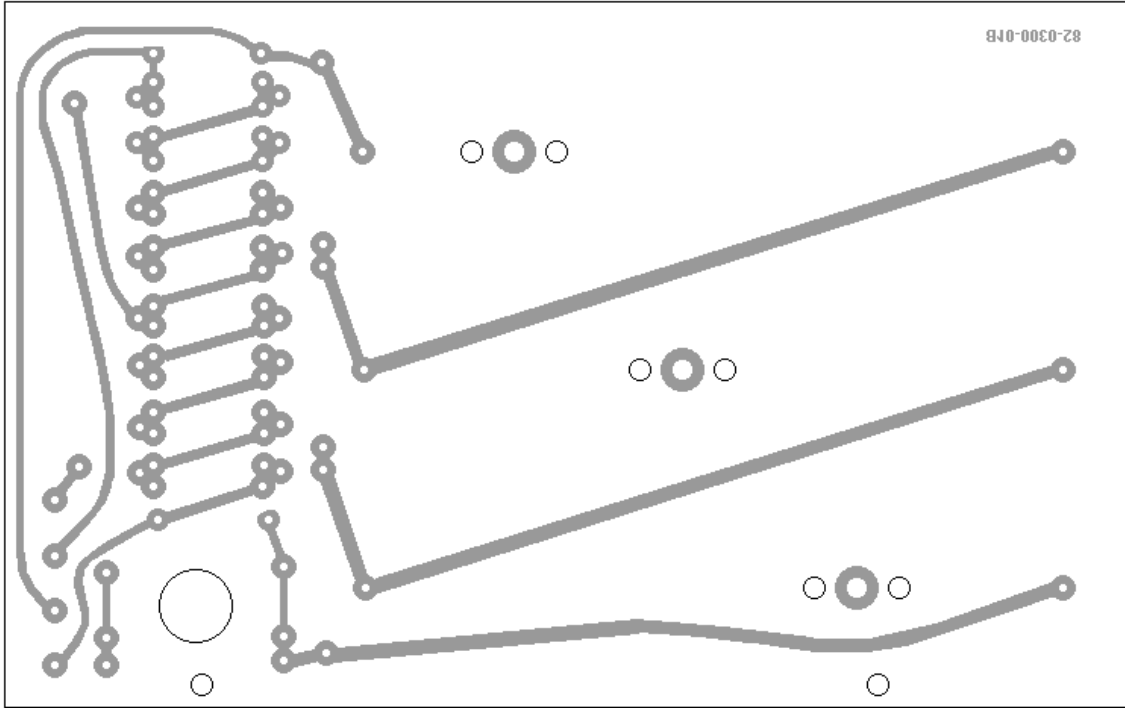

**PRIDE DX300 Bi Linear Amplifier
HIGH Voltage Power Supply PCB
82-0300-01B**
Copyright © 2004, CBTricks.com All Rights Reserved
Rev.# 1.0

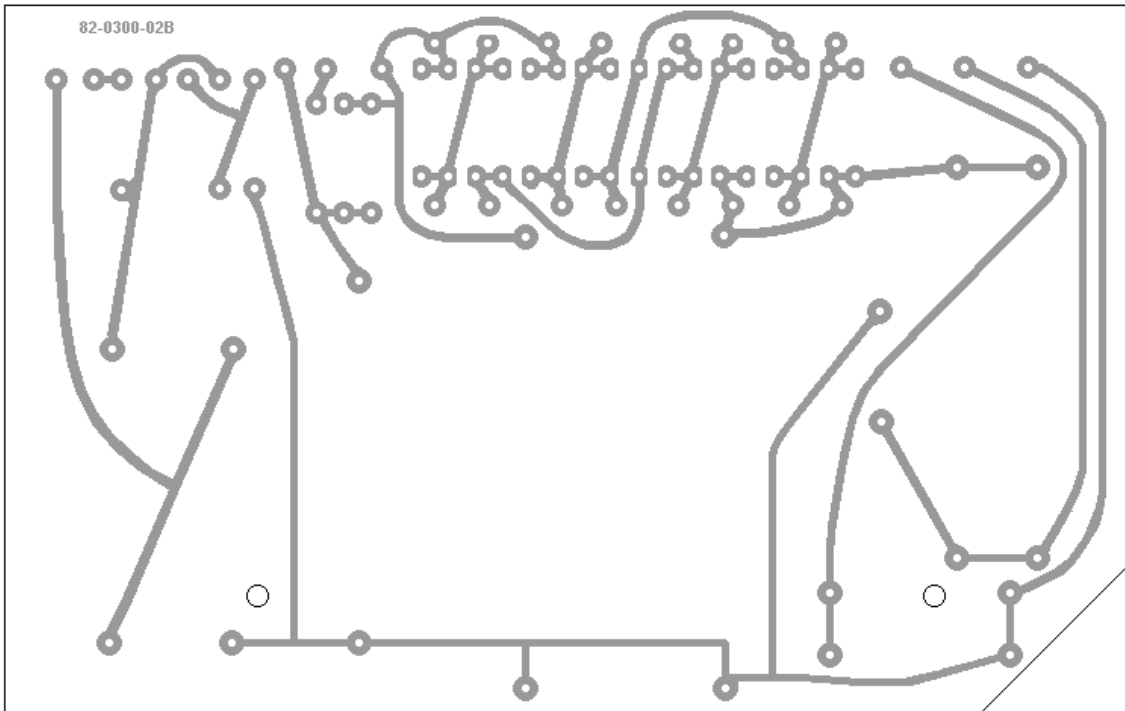

**PRIDE DX300 Bi Linear Amplifier
LOW Voltage Power Supply PCB
82-0300-02B**
Copyright © 2004, CBTricks.com All Rights Reserved
Rev.# 1.0

PCB Trace Layouts (Cont.):

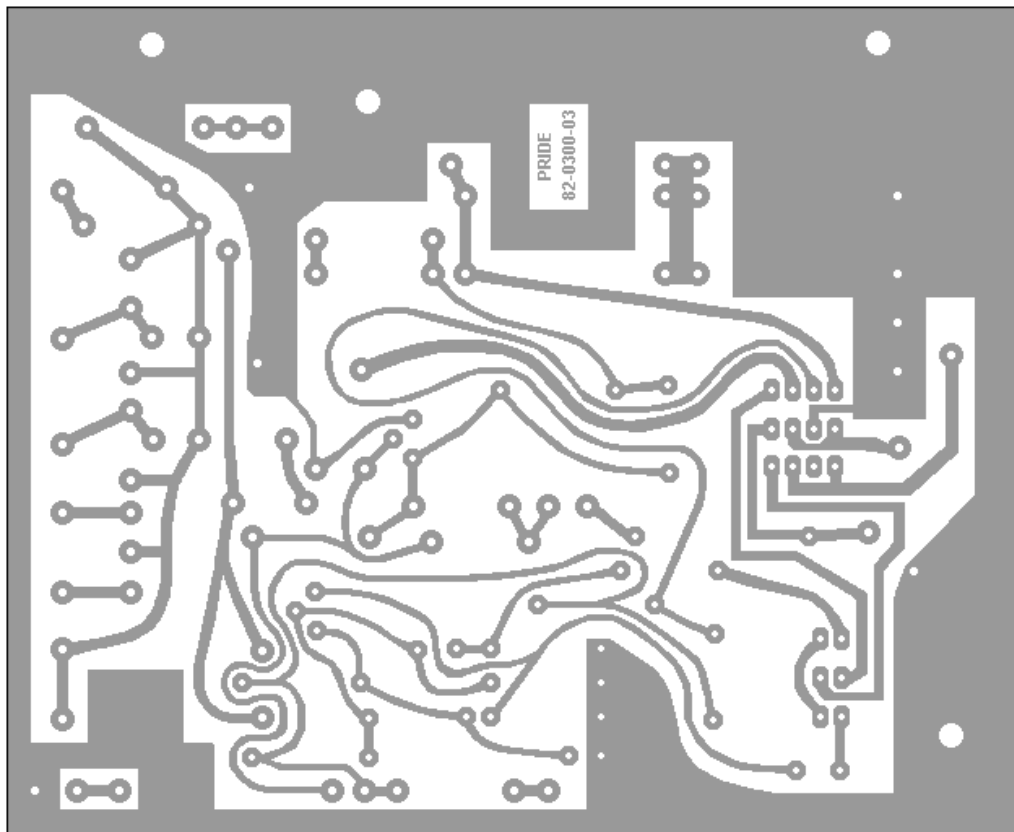

**PRIDE DX300 Bi Linear Amplifier
RF Relay and Control PCB 82-0300-03**
Copyright © 2004, CBTricks.com All Rights Reserved
Rev.# 1.0

5.7 Chassis Layouts Front and Rear:

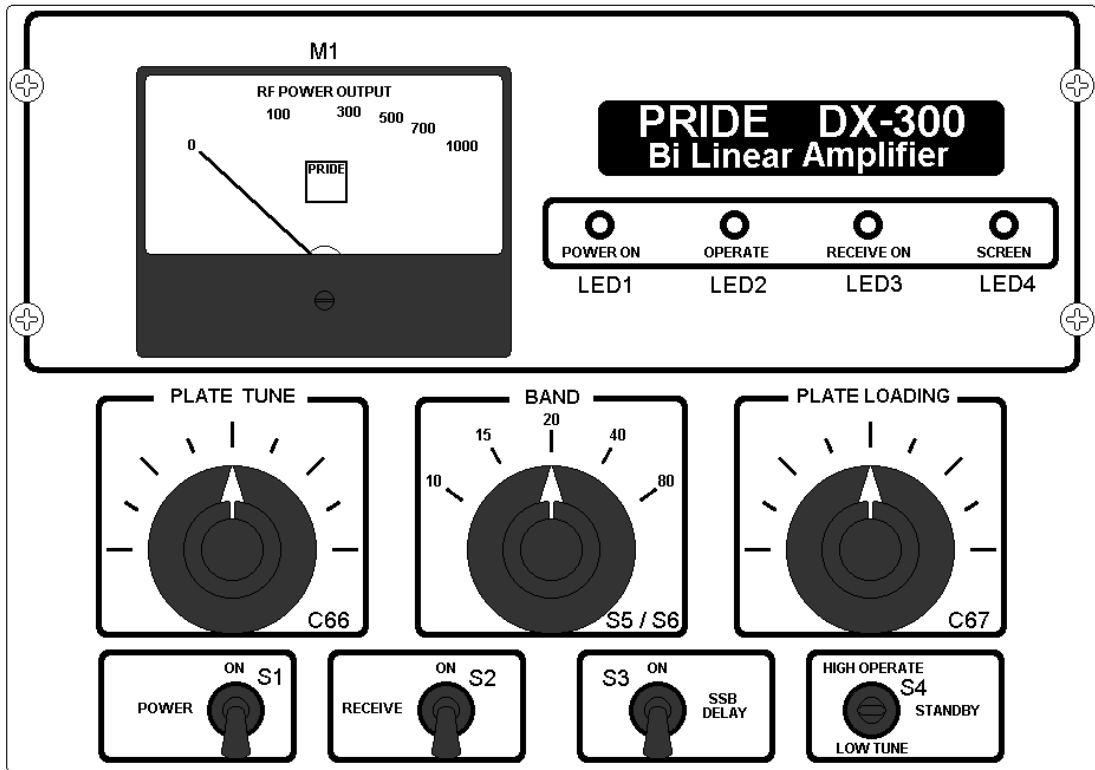

FRONT VIEW

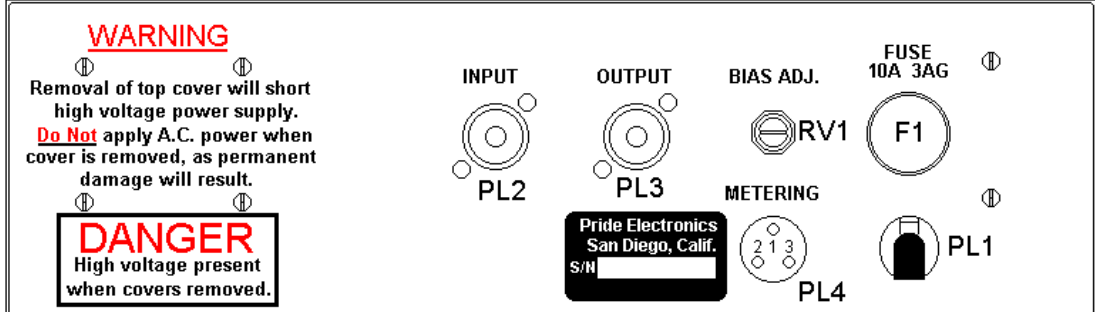
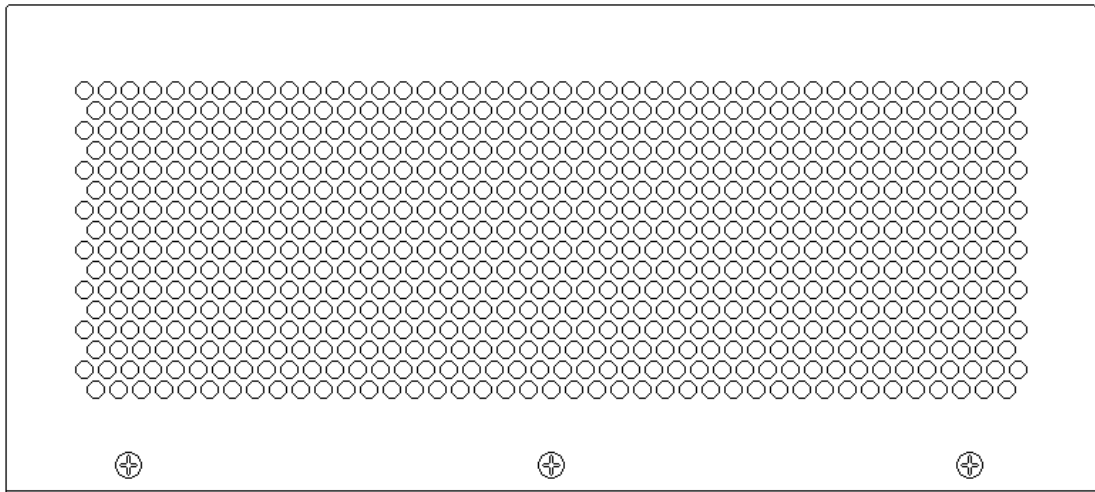

REAR VIEW

5.8 Chassis Layouts Top and Bottom:

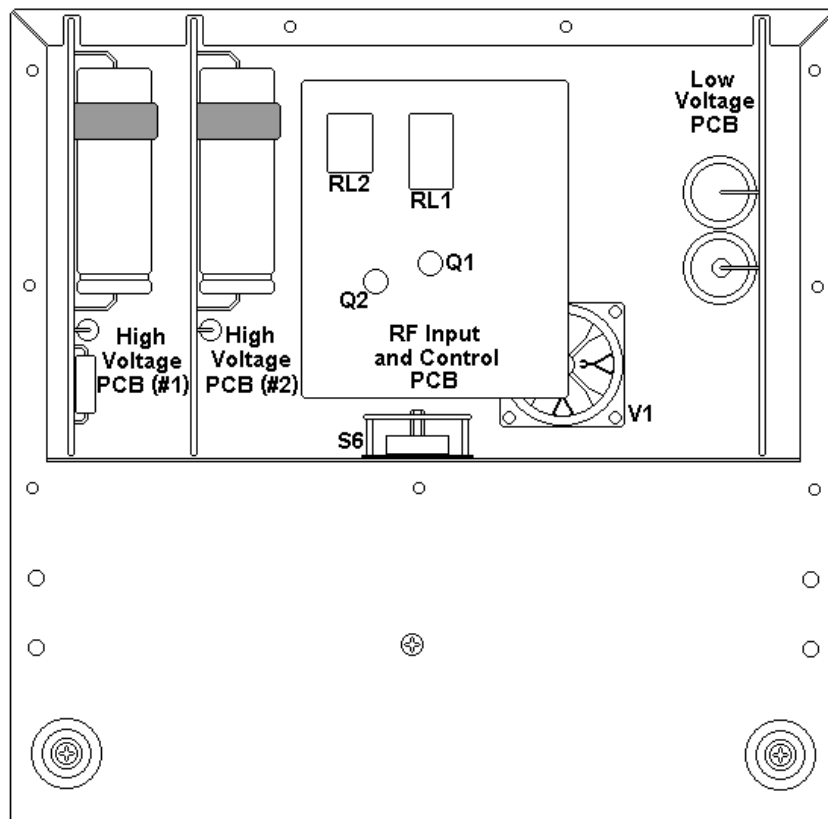
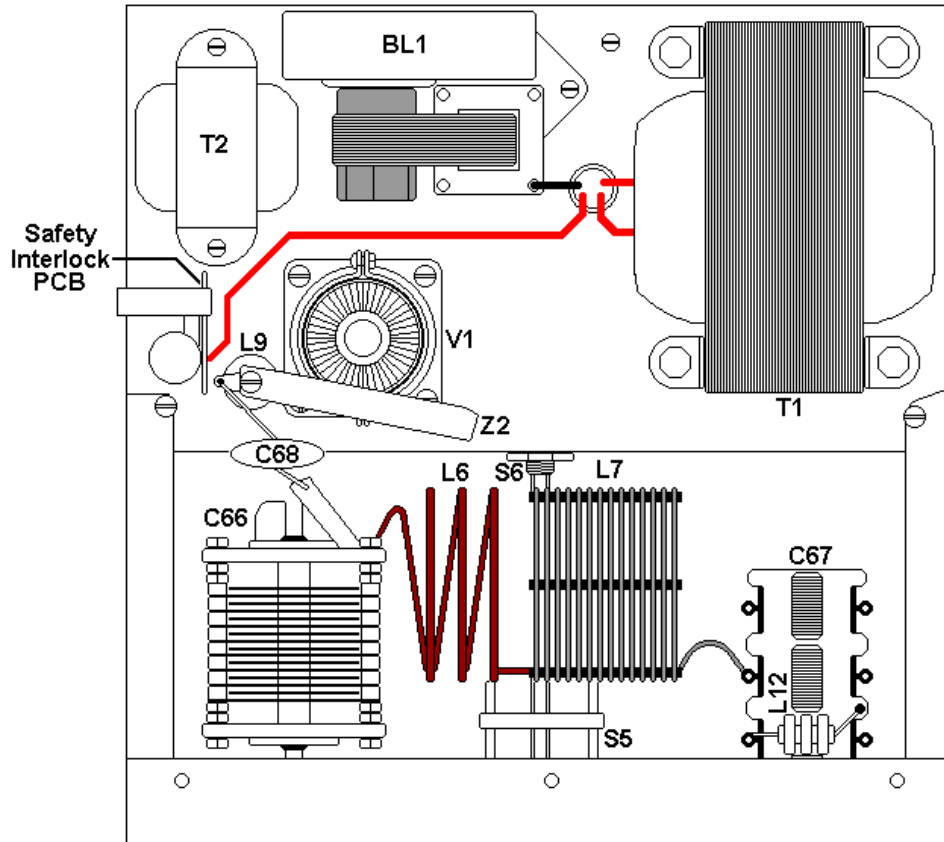

6.1 HIGH VOLTAGE PWR SUPPLY #1:

Ref. #	Description	MFR. Part No.
	ASSY DX-300 HIGH VOLTAGE PWR SUPPLY #1	01-0300-01
	PCB DX-300 HIGH VOLTAGE PWR SUPPLY	82-0300-01

Resistors

Ref. #	Description	MFR. Part No.
R13	Resistor, Carbon Film 470K Ohm 1/2W	06-4704-00
R14	Resistor, Carbon Film 470K Ohm 1/2W	06-4704-00
R15	Resistor, Carbon Film 470K Ohm 1/2W	06-4704-00
R16	Resistor, Carbon Film 470K Ohm 1/2W	06-4704-00
R17	Resistor, Carbon Film 470K Ohm 1/2W	06-4704-00
R18	Resistor, Carbon Film 470K Ohm 1/2W	06-4704-00
R19	Resistor, Carbon Film 470K Ohm 1/2W	06-4704-00
R20	Resistor, Carbon Film 470K Ohm 1/2W	06-4704-00
R21	Resistor, Carbon Film 150K Ohm 2W 10%	06-1504-02
R22	Resistor, Carbon Film 150K Ohm 2W 10%	06-1504-02
R23	Resistor, Carbon Film 150K Ohm 2W 10%	06-1504-02
R24	Resistor, Carbon Film 6.8 Ohm 2W 5%	06-0680-02
R25	Resistor, Carbon Film 6.8 Ohm 2W 5%	06-0680-02
R26	Resistor, Wire wound 25 Ohm 10W 10%	17-2500-10

Capacitors

Ref. #	Description	MFR. Part No.
C14	Capacitor, Ceramic Disk 0.001 μ F 1KV	08-0102-00
C15	Capacitor, Ceramic Disk 0.001 μ F 1KV	08-0102-00
C16	Capacitor, Ceramic Disk 0.001 μ F 1KV	08-0102-00
C17	Capacitor, Ceramic Disk 0.001 μ F 1KV	08-0102-00
C18	Capacitor, Ceramic Disk 0.001 μ F 1KV	08-0102-00
C19	Capacitor, Ceramic Disk 0.001 μ F 1KV	08-0102-00
C20	Capacitor, Ceramic Disk 0.001 μ F 1KV	08-0102-00
C21	Capacitor, Ceramic Disk 0.001 μ F 1KV	08-0102-00
C22	Capacitor, Electrolytic 100 μ F 450V	23-0107-45
C23	Capacitor, Electrolytic 100 μ F 450V	23-0107-45
C24	Capacitor, Electrolytic 100 μ F 450V	23-0107-45

Diodes

Ref. #	Description	MFR. Part No.
D9	Diode, Rectifier 1N4007 1 AMP 1000PIV	48-4007-00
D10	Diode, Rectifier 1N4007 1 AMP 1000PIV	48-4007-00
D11	Diode, Rectifier 1N4007 1 AMP 1000PIV	48-4007-00
D12	Diode, Rectifier 1N4007 1 AMP 1000PIV	48-4007-00
D13	Diode, Rectifier 1N4007 1 AMP 1000PIV	48-4007-00
D14	Diode, Rectifier 1N4007 1 AMP 1000PIV	48-4007-00
D15	Diode, Rectifier 1N4007 1 AMP 1000PIV	48-4007-00
D16	Diode, Rectifier 1N4007 1 AMP 1000PIV	48-4007-00

6.2 HIGH VOLTAGE PWR SUPPLY #2:

Ref. #	Description	MFR. Part No.
	ASSY.HIGH VOLTAGE PWR SUPPLY #2	01-0300-00
	HIGH VOLTAGE PWR SUPPLY PCB	82-0300-01

Resistors

Ref. #	Description	MFR. Part No.
R1	Resistor, Carbon Film 470K Ohm 1/2W	06-4704-00
R2	Resistor, Carbon Film 470K Ohm 1/2W	06-4704-00
R3	Resistor, Carbon Film 470K Ohm 1/2W	06-4704-00
R4	Resistor, Carbon Film 470K Ohm 1/2W	06-4704-00
R5	Resistor, Carbon Film 470K Ohm 1/2W	06-4704-00
R6	Resistor, Carbon Film 470K Ohm 1/2W	06-4704-00
R7	Resistor, Carbon Film 470K Ohm 1/2W	06-4704-00
R8	Resistor, Carbon Film 470K Ohm 1/2W	06-4704-00
R9	Resistor, Carbon Film 150K Ohm 2W 10%	06-1504-02
R10	Resistor, Carbon Film 150K Ohm 2W 10%	06-1504-02
R11	Resistor, Carbon Film 150K Ohm 2W 10%	06-1504-02
R12	Resistor, Wire wound 25 Ohm 10W 10%	17-2500-10

Capacitors

Ref. #	Description	MFR. Part No.
C3	Capacitor, Ceramic Disk 0.001 μ F 1KV	08-0102-00
C4	Capacitor, Ceramic Disk 0.001 μ F 1KV	08-0102-00
C5	Capacitor, Ceramic Disk 0.001 μ F 1KV	08-0102-00
C6	Capacitor, Ceramic Disk 0.001 μ F 1KV	08-0102-00
C7	Capacitor, Ceramic Disk 0.001 μ F 1KV	08-0102-00
C8	Capacitor, Ceramic Disk 0.001 μ F 1KV	08-0102-00
C9	Capacitor, Ceramic Disk 0.001 μ F 1KV	08-0102-00
C10	Capacitor, Ceramic Disk 0.001 μ F 1KV	08-0102-00
C11	Capacitor, Electrolytic 100 μ F 450V	23-0107-45
C12	Capacitor, Electrolytic 100 μ F 450V	23-0107-45
C13	Capacitor, Electrolytic 100 μ F 450V	23-0107-45

Diodes

Ref. #	Description	MFR. Part No.
D1	Diode, Rectifier 1N4007 1 AMP 1000PIV	48-4007-00
D2	Diode, Rectifier 1N4007 1 AMP 1000PIV	48-4007-00
D3	Diode, Rectifier 1N4007 1 AMP 1000PIV	48-4007-00
D4	Diode, Rectifier 1N4007 1 AMP 1000PIV	48-4007-00
D5	Diode, Rectifier 1N4007 1 AMP 1000PIV	48-4007-00
D6	Diode, Rectifier 1N4007 1 AMP 1000PIV	48-4007-00
D7	Diode, Rectifier 1N4007 1 AMP 1000PIV	48-4007-00
D8	Diode, Rectifier 1N4007 1 AMP 1000PIV	48-4007-00

6.3 B+ CIRCUITRY (Safety Interlock):

Ref. #	Description	MFR. Part No.
	ASSY. B+ CIRCUITRY (Safety Interlock)	01-0300-16
	PCB, B+ CIRCUITRY	82-0300-04

Inductors

Ref. #	Description	MFR. Part No.
L8	ASSY. Toriod Inductor 10 μ H 10 Windings	01-0300-28

Resistors

Ref. #	Description	MFR. Part No.
R59	Resistor, Carbon Film 150K Ohm 2W 10%	06-1504-02

Capacitors

Ref. #	Description	MFR. Part No.
C56	Capacitor, Ceramic Disk 0.005 μ F 3KV	08-0502-00

Ref. #	Description	MFR. Part No.
	Ground Strap, Safety Interlock	85-0300-15
	Bracket, B+ Circuitry	85-0300-18

6.4 LOW VOLTAGE PWR SUPPLY:

Ref. #	Description	MFR. Part No.
	ASSY. LOW VOLTAGE PWR SUPPLY	01-0300-02
	LOW VOLTAGE PWR SUPPLY PCB	82-0300-02

Resistors

Ref. #	Description	MFR. Part No.
R27	Resistor, Carbon Film 470K Ohm 1/2W	06-4704-00
R28	Resistor, Carbon Film 470K Ohm 1/2W	06-4704-00
R29	Resistor, Carbon Film 470K Ohm 1/2W	06-4704-00
R30	Resistor, Carbon Film 470K Ohm 1/2W	06-4704-00
R31	Resistor, Carbon Film 470K Ohm 1/2W	06-4704-00
R32	Resistor, Carbon Film 470K Ohm 1/2W	06-4704-00
R33	Resistor, Carbon Film 470K Ohm 1/2W	06-4704-00
R34	Resistor, Carbon Film 470K Ohm 1/2W	06-4704-00
R35	Resistor, Carbon Film 150 Ohm 1/2W 10%	06-1501-00
R36	Resistor, Carbon 30 Ohm 1/2W 5%	06-0301-00
R37	Resistor, Wire wound 20K Ohm 10W	17-2003-10
R38	Resistor, Wire wound 12K Ohm 10W 10%	17-1203-10
R39	Resistor, Wire wound 10K Ohm 10W 10%	17-1003-10
R40	Resistor, Carbon 3.3K Ohm 2W 5%	06-3302-02
R41	Resistor, Carbon 3.3K Ohm 2W 5%	06-3302-02
R42	Resistor, Carbon Film 680 Ohm 1/2W 5%	06-6801-00

Capacitors

Ref. #	Description	MFR. Part No.
C25	Capacitor, Ceramic Disk 0.001 μ F 1KV	08-0102-00
C26	Capacitor, Ceramic Disk 0.001 μ F 1KV	08-0102-00
C27	Capacitor, Ceramic Disk 0.001 μ F 1KV	08-0102-00
C28	Capacitor, Ceramic Disk 0.001 μ F 1KV	08-0102-00
C29	Capacitor, Ceramic Disk 0.001 μ F 1KV	08-0102-00
C30	Capacitor, Ceramic Disk 0.001 μ F 1KV	08-0102-00
C31	Capacitor, Ceramic Disk 0.001 μ F 1KV	08-0102-00
C32	Capacitor, Ceramic Disk 0.001 μ F 1KV	08-0102-00
C33	Capacitor, Electrolytic 40 μ F 450V	23-0406-45
C34	Capacitor, Electrolytic 40 μ F 450V	23-0406-45
C36	Capacitor, Electrolytic 1000 μ F 25V	22-0108-00
C37	Capacitor, Electrolytic 1000 μ F 25V	22-0108-00

Diodes

Ref. #	Description	MFR. Part No.
D17	Diode, Rectifier 1N4007 1 AMP 1000PIV	48-4007-00
D18	Diode, Rectifier 1N4007 1 AMP 1000PIV	48-4007-00
D19	Diode, Rectifier 1N4007 1 AMP 1000PIV	48-4007-00
D20	Diode, Rectifier 1N4007 1 AMP 1000PIV	48-4007-00
D21	Diode, Rectifier 1N4007 1 AMP 1000PIV	48-4007-00
D22	Diode, Rectifier 1N4007 1 AMP 1000PIV	48-4007-00
D23	Diode, Rectifier 1N4007 1 AMP 1000PIV	48-4007-00
D24	Diode, Rectifier 1N4007 1 AMP 1000PIV	48-4007-00
D25	Diode, Zener 82V 5W 1N5375	48-5375-00
D26	Diode, Rectifier 1N4001 1A 600PIV	48-4001-00
D27	Diode, Rectifier 1N4001 1A 600PIV	48-4001-00
D28	Diode, Rectifier 1N4001 1A 600PIV	48-4001-00

6.5 RF INPUT AND CONTROL BOARD:

Ref. #	Description	MFR. Part No.
	ASSY. RF INPUT AND CONTROL	01-0300-03
	RF INPUT AND CONTROL PCB	82-0300-03

Inductors

Ref. #	Description	MFR. Part No.
L1	Choke, SUB MIN 200 μ H NIN Q47 80 METERS	24-2000-00
L2	ASSY. Coil Input Toroid 40 METERS	01-0300-26
L3	ASSY. Coil Input Toroid 20 METERS	01-0300-25
L4	ASSY. Coil Input Toroid 15 METERS	01-0200-24
L5	ASSY. Coil Input Toroid 10 METERS	01-0300-23
L10	Choke, RF 22 μ H	24-2200-00
L11	Choke, RF 0.82 μ H	24-0820-00
L14	Choke, SUB MIN 200 μ H NIN Q47	24-2000-00
T3	ASSY. Input Transformer 3 Wires 10 Windings	01-0300-22

Resistors

Ref. #	Description	MFR. Part No.
R44	Resistor, Carbon 1.5K Ohm 2W 10%	06-1502-02
R45	Resistor, Carbon 1.5K Ohm 2W 10%	06-1502-02
R46	Resistor, Carbon 18K Ohm 2W 10%	06-1803-02
R47	Resistor, Carbon 18K Ohm 2W 10%	06-1803-02
R48	Resistor, Carbon 270 Ohm 2W 10%	06-2701-02
R49	Resistor, Carbon 270 Ohm 2W 10%	06-2701-02
R50	Resistor, Carbon Film 1K Ohm 1W	06-1002-01
R51	Resistor, Carbon Film 470 Ohm 1/2W 5%	06-4701-00
R52	Resistor, Carbon Film 680 Ohm 1/2W 5%	06-6801-00
R53	Resistor, Carbon Film 680 Ohm 1/2W 5%	06-6801-00
R54	Resistor, Carbon Film, 10K Ohm 1/2W 5%	06-1003-00
R55	Resistor, Carbon Film 270 Ohm 1/2W 5%	06-2701-00
R56	Resistor, Carbon Film 470 Ohm 1/2W 5%	06-4701-00
R57	Resistor, Carbon Film 68K Ohm 1/2W 5%	06-6803-00
R58	Resistor, Carbon Film 1K Ohm 1/2W 5%	06-1002-00

Capacitors

Ref. #	Description	MFR. Part No.
C39	Capacitor, Ceramic Disk 0.01 μ F 1KV	08-0103-02
C40	Capacitor, Ceramic Disk 0.01 μ F 1KV	08-0103-02
C41	Capacitor, Dipped Mica 39pF 5% DM15	21-1390-00
C42	Capacitor, Dipped Mica 10pF 5% DM15	21-1100-00
C43	Capacitor, Ceramic Disk 0.01 μ F 1KV	08-0103-02
C50	Capacitor, Ceramic Disk 0.01 μ F 50V	05-0103-00
C51	Capacitor, Electrolytic 35 μ F 25V Axial	22-0356-00
C52	Capacitor, Ceramic Disk 0.001 μ F 1KV	08-0102-00
C53	Capacitor, Dipped Mica 120pF 5% DM15	21-1121-00
C54	Capacitor, Dipped Mica 50pF 5% DM15	21-1500-00
C55	Capacitor, Ceramic Disk 0.001 μ F 1KV	08-0102-00

Diodes

Ref. #	Description	MFR. Part No.
D29	Diode, Signal 1N914	48-0914-00
D30	Diode, Rectifier 1A 50V Plastic	48-4001-00
D31	Diode, Rectifier 1A 50V Plastic	48-4001-00
D32	Diode, Signal 1N914	48-0914-00

Relays

Ref. #	Description	MFR. Part No.
RL1	Relay, 4PDT Allied Control TY154-4C-12DC	41-1024-00
RL2	Relay, 2PDT Potter & Brumfield R10-E1-Y2-V185	41-1022-01

Transistors

Ref. #	Description	MFR. Part No.
Q1	Transistor, 2N2905 PNP SI Switching	48-2905-00
Q2	Transistor, 2N2905 PNP SI Switching	48-2905-00

6.6 WATTMETER PCB:

Ref. #	Description	MFR. Part No.
	ASSY. WATTMETER PCB	01-0300-09
	WATTMETER PCB	82-0300-06
Inductors		
Ref. #	Description	MFR. Part No.
T4	ASSY. Toroid Coil 17 Winding	01-0300-27
Resistors		
Ref. #	Description	MFR. Part No.
RV2	Potentiometer, Trimpot 50K Ohm 1/4 W	19-5003-00
R60	Resistor, Carbon Film 15K Ohm 1/2W 5%	06-1503-00
R61	Resistor, Carbon Film 68 Ohm 2W 5%	06-6800-02
Capacitors		
Ref. #	Description	MFR. Part No.
C57	4-60pF	
C58	Capacitor, Dipped Mica 330pF 5% DM-15	21-1331-00
C59	Capacitor, Ceramic Disk 0.001 μ F 1KV	08-0102-00
C60	Capacitor, Ceramic 0.1 μ F 100V	08-0104-02
Diodes		
Ref. #	Description	MFR. Part No.
D33	Diode, Signal 1N914	48-0914-00
Meters		
Ref. #	Description	MFR. Part No.
M1	Meter, 1ma F.S. With Special Scale	49-0300-00

6.7 CHASSIS

Ref. #	Description	MFR. Part No.
C1	Capacitor, Ceramic Disk 0.01 μ F 1KV	08-0103-02
C2	Capacitor, Ceramic Disk 0.01 μ F 1KV	08-0103-02
C35	Capacitor, Ceramic Disk 0.001 μ F 1KV (Across LED4)	08-0102-00
C44	Capacitor, Ceramic Disk 0.01 μ F 1KV	08-0103-02
C45	Capacitor, Ceramic Disk 0.01 μ F 1KV	08-0103-02
C46	Capacitor, Ceramic Disk 0.01 μ F 1KV	08-0103-02
C47	Capacitor, Ceramic Disk 0.01 μ F 1KV	08-0103-02
C48	Capacitor, Ceramic Disk 0.01 μ F 1KV	08-0103-02
C49	Capacitor, Ceramic Disk 0.01 μ F 1KV	08-0103-02
C62	Capacitor, Ceramic Disk 0.01 μ F 1KV	08-0103-02
C63	Capacitor, Dipped Mica 360pF 1KV	21-1361-01
C64	Capacitor, Dipped Mica 360pF 1KV	21-1361-01
C65	ASSY. CAPACITOR 165pF TEFLON DIELECTRIC	01-0300-13
	Teflon Sheet 4.50 X 3.50	85-0300-04
	Teflon Plug 1.0 DIA	85-0300-05
	Brass Sheet 4.00 X 3.00	85-0300-06
	Teflon Sheet 2.00 X 2.00	85-0300-07
	Brass Sheet 1.40 X 1.40	85-0300-08
C66	Capacitor, Variable, Panel 10-110pF 3KV	20-1101-03
C67	Capacitor, Variable, Panel 1350pF 750V (450pF x 3)	20-2450-00
C68	Capacitor, Ceramic Disk 0.0022 μ F 7.5KV	08-0222-07
C69	Capacitor, Ceramic Disk 0.001 μ F 1KV (Across LED3)	08-0102-00
C70	Capacitor, Ceramic Disk 0.01 μ F 1KV	08-0103-02
Ref. #	Description	MFR. Part No.
S1	Switch, SPST, 10A	40-8006-00
S2	Switch, 3A SPST	40-1606-00
S3	Switch, 3A SPST	40-1606-00
S4	Switch, DPDT, Center Off 10A	40-8706-00
S5	Switch, Band Ceramic 2 Wafer 5 Position	40-9002-00
	Coupler, Shaft	26-0138-00
S6	Switch, Phonetic 1 Pole 5 Position	40-3000-00

CHASSIS (Cont.)

Ref. #	Description	MFR. Part No.
L7	ASSY. Tank Coil 15-80 Meters	01-0300-15
L12	Choke, RF 1mH 160 MA	24-1006-00
	Capacitor Strap	85-0300-17

Ref. #	Description	MFR. Part No.
	Dial, Figure Black DX-300	32-0299-00
	Knob, Black DX-300	32-2912-00
	Knob, Black DX-300	32-2912-01
	CAP. Knob DX-300	42-0290-00
LED1	L.E.D. Red Diffused	49-5024-00
LED2	L.E.D. Red Diffused	49-5024-00
LED3	L.E.D. Red Diffused	49-5024-00
LED4	L.E.D. Red Diffused	49-5024-00
	Clip & Ring, LED Panel Mounting	05-5024-00
Z1	Parasitic Suppressor, Grid 4Turns #22	01-0300-07
	Resistor, Carbon Film 150 Ohm 1/2W (R65)	
Z2	ASSY. Parasitic Suppressor	01-0300-05
	Resistor, Carbon Film 100 Ohm 2W (R62)	
	Resistor, Carbon Film 100 Ohm 2W (R63)	
	Resistor, Carbon Film 100 Ohm 2W (R64)	
L9	Choke, RF Plate 55µH	24-0014-00
T1	Transformer, DX-300 High Voltage	25-0300-01
T2	Transformer, DX-300 Low Voltage	25-0300-02
BL1	Blower, High Output Modified	87-1250-00
	Flange, Outlet For Blower PN 87-1250-00	87-1250-01

Ref. #	Description	MFR. Part No.
V1	Tube, 4CX250B	65-0250-00
	Socket, Electron Tube E.F. Johnson 124-110	09-0250-00
	Screen bypass Cap, Round Frame E.F. Johnson 124-113-001	
	Socket Chimney, E.F. Johnson 124-0111-011	09-0250-01

Ref. #	Description	MFR. Part No.
PL-1	Line Cord. 3 Wire 1118W Molded Plug	28-3186-00
PL-2	SO239 (RF Input)	
PL-3	SO239 (RF Output)	
PL-4	Recept 3-COND Round (Metering Jack)	09-7135-00
RV1	POT. 500 Ohm 2.25W 10% SCR. ADJ. .625 SHFT	18-5001-02
F1	Fuse, AGC 10 AMP	65-0010-00
	Fuse Extractor Post	67-1200-00

Ref. #	Description	MFR. Part No.
	Foot, Rubber 31/32"	75-2135-00
	Cover	85-0300-11
	Bottom Plate	85-0300-14

Circuit Modifications

7.0 Introduction

NOTE:

**Exercise a great deal of care with any Modifications done
Due to the high Voltage, and close proximity of the surrounding components.
If done wrong you could destroy components / or KILL yourself.**

**If you have even the slightest doubts or the proper equipment, it would be wise to have someone else
you trust perform the mod for you.**

SO TAKE YOUR TIME AND DOUBLE CHECK YOUR WORK!!!!

7.1 Screen LED Modification

The 'Screen' LED (**LED4**) seldom lasts long, but we use a 2W part for R35 and R36, same resistance values. The LED will still die if there's a surge on the screen, but the larger resistors take it better than the stock 1/2W parts.

7.2 Screen Supply Modification

The Pride DX300 has no screen regulation and should, Nomad Radio (<http://www.nomadradio.com>) is working on a new Low Voltage PCB. I have seen Prides with a 25K 10W to ground on the +350v supply. A person could build a regulator for the supply. So check his web site for details.

7.3 Tube Oscillation

Adding another capacitor on the B+ side of the plate choke can stop oscillation of the tube. Typically .001 μ F at 3000Volts

7.4 Wattmeter PCB Modification (Nomad Radio Mod)

On the small circuit board bolted to the rear of the meter, the output coax should be **SOLDERED DIRECTLY TO THE BOARD**. First unplug the two coax cables from it. Loosen the nuts on the meter posts, and **GENTLY** pull the board away from the meter body.

You will need to unsolder the bare ground wire from the inboard-lower corner.

Heat the solder to the four pins where the two coaxes were plugged in, and pull them completely out of their holes. You will need to ream the two ground holes (the ones on the outside edge) out to a hole size of about 3/32 of an inch. You also need to clear any leftover solder from the two holes where the coax center wires attach.

Remove the spring contacts from both the coax cables that you unplugged from the meter board. Strip about 3/8 of an inch from the end of each. You should also pull off the shrink tubing that covers the coax braid. Tin each of these wire ends to hold all those loose strands together. Now insert the tinned wire ends back into the four holes in the meter board. Solder them in place, and that skinny bare ground wire on the corner of the board. When the meter board is mounted back onto the meter posts.

7.5 Bias Circuit Modification Version 1 (Nomad Radio Mod)

The Bias voltage is a Negative 82 Volt supply which is set between -65 and -68 volts to the tube. The most common part failure is the bias pot (RV1) 500ohm 2W linear pot and an 82-Volt 5-Watt zener (D25). One substitute for the stock (D25) setup is three 20 Volt 5 Watt zeners in series. For people who want a bias control that will turn all the way down past cutoff, use a string of six for the "-R" version of the tube, and five of them for the stock "-B" tube. It looks a little over-the-top, but never comes back blown.

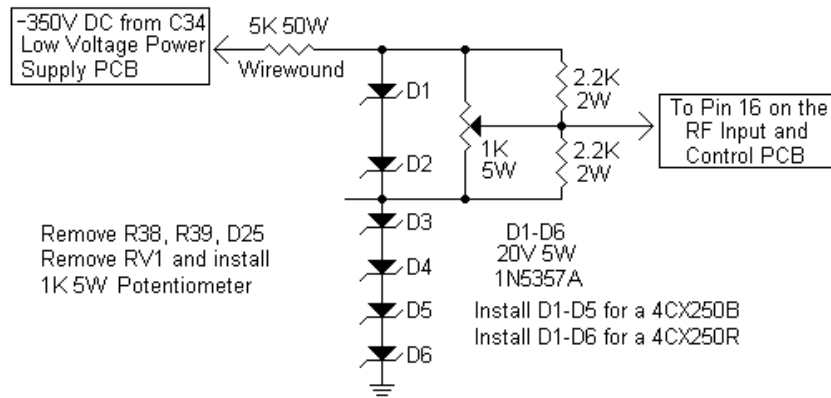

Figure 7-1 Zener Bias Mod

The space the zeners occupy here is normally where the two very-hot 10-Watt resistors R38 and R39 go. You can locate a single 5K 50W resistor off the board to do that job. It runs cooler and leaves room for five or six zeners in series on the low voltage power supply PCB.

With six zeners installed the pot has an end-to-end range of 40 Volts, more or less. For the '250R, this is from -120 to -80. For the '250B, with just five zeners installed, is -100 to -60. This permits biasing the tube past cutoff, and provides a "rollback" or carrier control for a radio that doesn't have one built in. And it helps to reduce the heat load on the tube from the carrier power.

7.6 Bias Circuit Modification Version 2

Another way is to use a transistor and zener. The following uses two TIP50's (you can use one transistor as long as the one you use can handle the current and voltage). Every shop has a pile TIP50's laying around and they are cheap. You can use the stock D25 for the zener or series as many lower voltage 1W zeners you need to get the voltage range you like.

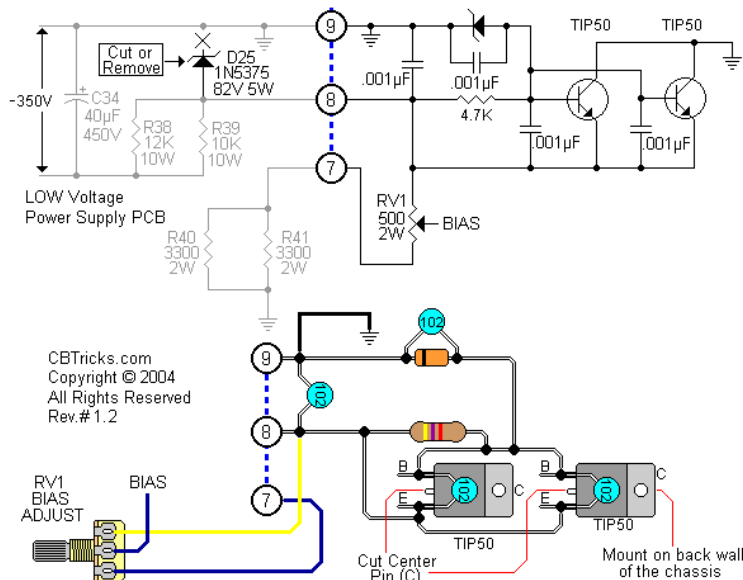

Figure 7-2 Transistor / Zener Bias Mod

8.0 Introduction:

In this section I have information on some of the components use in the DX300.

8.1 Antenna Change Over and Preamp Relay Information:

The antenna change over relay (**RL1**) is a 4- pole double throw (4PDT) relay with 10 amp contacts and a 12 volt 185ohm coil. I've always seen an Allied Control relay here. Part number TY154 CC-CC 12VDC. The current part number to order would be TY154 4C 12VDC with only change being the way the "C's" are entered. Potter & Brumfield have a similar relay with contacts rated at only 7.5 amps but it would probably work in a pinch. That part number would be R10-E1-W4-V185.

The pre-amp relay (**RL2**) is usually a Potter & Brumfield. The original part number would be R10-E1-Y2-V185. That crosses over to a NTE R16 11D3 12. It is a 2PDT type with 3 amp contacts and a 12 volt 185ohm coil.

8.2 Band Switch:

If the amp is keyed up and the band switch (**S5**) is turned while still keyed, the band switch is ruined for good - the contacts will burn so badly that the entire switch will have to be replaced. The Band switch I haven't found a replacement.

8.3 Input Coil Information:

T3, the 9-1 (impedance) step-up input transformer "3 wires, 10 windings" "trifilar"

- L5: 10 meters is 12 turns #24 shows 0.75 μ H.
 13 TURNS, APPROX 0.9 μ H, works better on 27 MHz.
 Core: 7/16" OD x 7/32" ID x 5/32" thick. Yellow/black
 Probably a "-6" powdered-iron core.
- L4: 15 meters is 17t. shows 1.4 μ H. same core
- L3: 20 meters is 23t. shows 2.4 μ H same core
- L2: 40 meters is 31t. on a larger core, shows 6 μ H.
 Core: 11/16" OD (T-68?) x 3/8" ID x 7/32" thick red,
 probably "-2" powdered-iron mix.
- L1: 200 μ H RF choke.

8.4 Z1 Information:

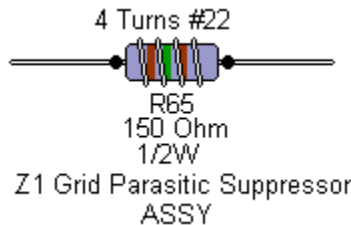

8.5 Z2 Information:

If the resistors look like toast, new resistors should be installed before you try to run it.

If the resistors look okay, and it has all 3 of them, leave it alone. If you replace them, we recommend using a 5-Watt rated 100-ohm carbon-film or metal-film resistor.

They will withstand more abuse than the original 2 Watt-rated parts.

DO NOT USE WIRE WOUND RESISTORS Period. Mouser Electronics, Westgate Labs and RF Parts sell this resistor.

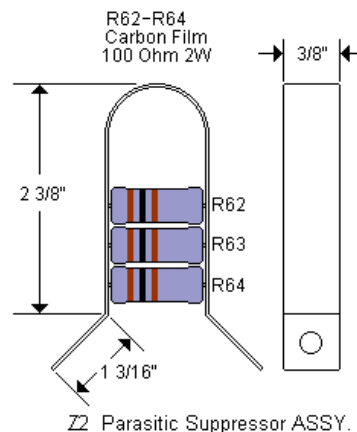

8.6 Blower Detail:

HOWARD INDUSTRIES PART NUMBER FOR THE BLOWER: 3-20-1250
 I think this translates to "3-inch wheel", 20 CFM at 1250 rpm.
 RF Parts has this Blower #87-1250 for \$39.95

8.7 Repair Part Suppliers

<p>RF Parts Company 435 South Pacific Street San Marcos, CA 92078 http://www.rfparts.com/ Orders and Information (800) 737-2787 (760) 744-0700 7:00 a.m. to 4:00 p.m. PST Mon-Fri Technical Help and Customer Service (760) 744-0750 10:00 a.m. to 4:00 p.m. PST Mon-Fri Tech Help is NOT available through the 800 line Fax (888) 744-1943 (760) 744-1943</p>	<p>WESTGATE LABORATORIES L.L.C. 1859 Caravan Trail, Suite #106 Jacksonville, FL 32216 http://www.westgateparts.com/ 1-800-213-4563 Local: (904) 997-2031 Fax: (904) 997-2041 Email: WestgateParts@aol.com</p>
<p>Surplus Sales of Nebraska 1502 Jones Street Omaha, NE 68102-3112 http://www.surplussales.com/ Toll free: (800) 244-4567 Local: (402) 346-4750 Fax: (402) 346-2939 e-mail: grinnell@surplussales.com</p>	<p>Mouser Electronics, Inc. 1000 North Main Street Mansfield, Texas 76063 http://www.mouser.com/ (800) 346-6873 Local: (817) 804-3888 Fax: (817) 804-3899 sales@mouser.com</p>
<p>Nomad Radio 1615 Bardstown Road Louisville, KY 40205 http://www.nomadradio.com info@nomadradio.com Add-on" and replacement accessories for various amateur, CB radios and amplifiers.</p>	

Nomad Radio Heavy-Duty High-Voltage power-supply board kit for the Pride DX-300 base amplifier.

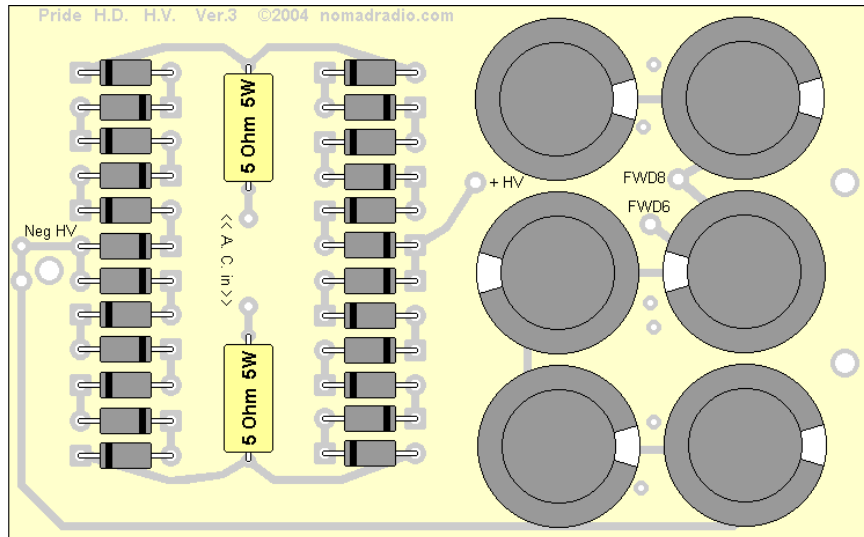

The Kit includes all the parts to build a single PCB HV Power Supply that replaces both HV PCB in a Pride DX300. This PCB lets you completely remove the original two H.V. circuit boards and install the single-piece replacement.

The Kit has the following components.

- 1) HDHV version 3 printed-circuit board
- 6) 180 μ F 450-Volt radial "snap-in" electrolytic capacitors.
- 2) 5-ohm 5-Watt wirewound power resistors
- 7) 240K ohm 2-Watt carbon-film bleeder resistors
- 26) 1N5408 3-Amp 1000-Volt rated rectifier diodes.

Nomad Radio
 1615 Bardstown Road
 Louisville, KY 40205
<http://www.nomadradio.com>
info@nomadradio.com

