

1 - P

QRO HF-1000 QSK LINEAR AMPLIFIER

INSTRUCTION MANUAL

Ser. No. 5475



TM

QRO TECHNOLOGIES, INC.

1117 West High Street
P.O. Box 939
Bryan, OH 43506 USA
Tel: (419) 6362721/Fax: (419) 636-6039
Email: qrotec@bright.net
Internet: <http://www.qrotec.com>

PUBLICATION DATE: JUNE 1995

Rev. 1/97

COPYRIGHT 1995 BY QRO TECHNOLOGIES, INC. ALL RIGHTS RESERVED.
THIS MANUAL OR ANY PART THERE OF MAY NOT BE REPRODUCED IN ANY FORM WITHOUT
PERMISSION FROM QRO TECHNOLOGIES, INC.

SPECIFICATIONS

Band Coverage:	160, 80, 40, 20, 17, and 15 (12 & 10 export only) meter amateur bands. 12 & 10 meter also useable in USA with proof of license and user modification.
Drive Power Required:	80 Watts Typical
Maximum Output Power:	1,000 Watts SSB, 800 Watts CW, 400 Watts RTTY, FM, SSTV
Duty Cycle:	100% SSB Continuous Voice Modulation 80% CW 50% RTTY, FM, SSTV. Continuous Carrier (Dead Key) 15 minute time limit at 400 watts with Auxiliary cooling
Automatic Limiting Control (ALC):	0 to -20 Volts negative going, adjustable from Front Panel
Harmonic Suppression:	2nd -45 db or better, 3rd - 10th -50 db or better
Keying:	Requires contact closure or sink of +12 VDC @ 80 ma or +15 VDC on transmit supplied by transceiver
Input Impedance:	50 ohms unbalanced
Output Impedance:	50 ohms unbalanced with SWR 2:1 or less
Tube Requirement (1):	3-500Z, 3-500ZG
Power Line Requirement:	100/120 VAC, 50/60 Hz at 20 amperes maximum 200/240 VAC, 50/60 Hz at 10 amperes maximum
Front Panel: (See Front Panel Pictorial)	Multimeter (Plate Voltage, Plate Current, Power Output PEP, Relative ALC) Grid Current Meter Multimeter Function Switch Transmit LED Indicator Power LED Indicator Power On/Off Switch Tune & Load Controls with 6-1 Reduction Drives Bandswitch
Rear Panel: (See Rear Panel Pictorial)	RF Input (SO-239) RF Output (SO-239) Transmit Keying Line (RCA Phono Socket) or

+15 V Supplied by Transceiver on Transmit (RCA Phono Socket)

ALC Output (RCA Phono Socket)

Tuned Input Adjustments (160, 80, 40, 20, 17, 15, 12, and 10 meters)

Ground Post

→ Fuses (two 20 ampere for 100/120 VAC or two 10 ampere for 200/240 VAC)

2x10A

Dimensions:

18w x 15d x 8-1/2h (Inches)

45.7w x 38.1d x 21.6h (Centimeters)

Net Weight:

65 lbs. or 29.5 kgs.

TABLE OF CONTENTS

Warranty	4
Proprietary Notice	4
Safety Notification	5
Unpacking & Inspection	6
Transformer & Tube Installation	6, 7
Line Voltage Selection Power Block Wiring	7
Reshipment Instructions	7
Introduction	8
Location	7
AC Power Line Considerations	8,9
Antenna	9
Grounding	9
Equipment Interconnections	10
Safety Interlock Switch	10
Driving Power	10
Tube	11
Reading the Meters	11
Tune-Up Procedure	11,12
Using the ALC Adjust Control	13
Tuned Input Adjustments	13, 14
Periodic Maintenance	14
Troubleshooting Chart	14-17
Circuit Descriptions	18-22
Addendum #1	Power Block Wiring
Addendum #2	Schematics
Addendum #3	PCB Layouts
Addendum #4	Front & Rear Panel Pictorials

WARRANTY

The HF-1000 is warranted against defects in material and workmanship for a period of two years for the original date of sale. This warranty does not cover the 3-500 triode which carries a separate warranty issued by its manufacturer. Please check the warranty card which comes with the tube. During the warranty period, QRO Technologies, Inc. will repair or replace the amplifier at our option if it is defective in any way in material and workmanship. The warranty does not cover any defects resulting from improper use by the buyer or inadequate maintenance. In such cases the repair will be billed at prevailing service rates.

For warranty service or repair, the amplifier must be returned to the factory for authorized service. The buyer shall prepay shipping and insurance charges, QRO Technologies, Inc. will pay shipping and insurance charges to return the amplifier to the buyer. Please call the factory at 1-800-956-2721 for shipping instructions. Make sure when returning the amplifier you have insured the instrument for the full replacement cost. QRO Technologies, Inc. is not liable for any damage incurred during return shipments.

PROPRIETARY NOTICE

This instruction manual, schematic diagrams, and technical data herein disclosed, are proprietary to QRO Technologies, Inc. and shall not, without express written permission of QRO Technologies, Inc., be used, in whole or part to solicit quotations from a competitive source or used for manufacturing by anyone other than QRO Technologies, Inc. The information herein has been developed at private expense, and may only be used for operation and maintenance reference purposes or for purposes of engineering evaluation and incorporation into technical specifications and other documents which specify procurement of products from QRO Technologies, Inc. This amplifier is covered by copyrights both in the United States of America and throughout the world.

ALWAYS THINK SAFETY

THIS LINEAR AMPLIFIER DESCRIBED IN THIS MANUAL CONTAINS VOLTAGE HAZARDOUS TO HUMAN LIFE AND SAFETY WHICH IS CAPABLE OF INFLICTING PERSONAL INJURY. NEVER OPERATE THE AMPLIFIER WITH THE TOP COVER REMOVED AND THE TOP COVER SAFETY SWITCH DEFEATED. BEFORE REMOVING THE TOP COVER MAKE SURE THE AC LINE POWER CORD HAS BEEN DISCONNECTED FROM THE AC POWER SOURCE. ALLOW A MINIMUM OF 5 MINUTES TO ELAPSE BEFORE REMOVING THE TOP COVER AFTER POWER HAS BEEN REMOVED. THIS IS NECESSARY TO ALLOW THE PLATE VOLTAGE FILTER CAPACITORS TO BLEED DOWN TO A SAFE LEVEL.

If this amplifier is to be powered from the AC line (mains) through an autotransformer (such as a Variac or equivalent) ensure that the common connector is connected to the neutral (earth pole) of the power supply.

Before operating this unit ensure that the protection conductor (green wire) is connected to the ground (earth) protective conductor of the power outlet. Do not defeat the protective features of the third protective conductor in the power cord by using a two conductor extension cord or a three-prong/two-prong adapter.

Before operating this unit:

1. Ensure that the instrument is configured to operate on the voltage available at the power source. (See Installation Section)
2. Ensure that the proper fuses are in place in the amplifier's AC line fuse holders located on the rear panel.
3. Ensure that all other devices connected to or in proximity to this amplifier are properly grounded or connected to the protective third-wire earth ground.

If at any time the amplifier shows visible damage, has sustained stress, emits a foul smell, fails to operate satisfactorily, it should not be used until its performance has been checked by qualified service personnel.

UNPACKING AND INSPECTION

The amplifier is shipped in three cartons: amplifier, transformer, tube. Before unpacking each carton, check the exterior of the shipping carton for any sign of damage. All irregularities should be noted. Unpack and remove each component carefully from its carton, preserving the factory packaging as much as possible. Inspect each component for any noticeable defect or damage. Notify QRO Technologies if any defect or damage is apparent.

TRANSFORMER AND TUBE INSTALLATION

Before performing any of the following installation procedures, make sure that the amplifier has not been plugged into the AC supply line.

The Amplifier is shipped with the tube and transformer each shipped in a separate carton. As part of the installation process, you must install the tube and transformer. You will need the following tools:

1. Phillips Screwdriver
2. Awl or suitable hole alignment tool
3. Adjustable wrench

Remove the Amplifier's top cover by removing the nine 6-32 x 3/8 Phillips Head machine screws and their associated flat washers. The sides of the top cover may bend outward when the screws are removed. This is normal, and they will return when you replace the screws and washers.

TRANSFORMER: Remove the transformer from its shipping carton. You will notice two connectors on the ends of the transformer leads. The smaller connector is for the primary leads, and the larger connector is for the secondary leads. Position the amplifier so the front panel is facing you. Position the transformer so the primary leads are on your right and the secondary leads are on your left. The amplifier's transformer compartment should be on the right side. Observe there are matching primary and secondary leads coming from the amplifier. The primary leads originate on the back panel, and there are three black leads and three white leads. The nine secondary leads originate from the center divider panel. The primary and secondary leads of the transformer and amplifier have matching "mate & lock" connectors. Place the transformer into the transformer compartment with the secondary leads on the right and the primary leads on the left. The transformer's four mounting holes should align with the four mounting screws coming out of the amplifier's bottom panel. Secure the transformer with two 1/4-20 hex nuts on the two right side mounting screws. Connect the primary and secondary "Mate & Lock" connectors together. Each connector is indexed so they connect only one way, and you will hear a distinctive click when they are correctly mated. **Make sure the primary leads coming from the transformer do not obstruct or prevent the free movement of the cooling fan. Check to see if the step-start relay contact arm, located on the rear panel just above the cooling fan, has not been placed out of position during installation. Make a check of all chassis wiring around the transformer to make sure no wiring has been pinched by the transformer's mounting plate. Correct any observed problems.**

TUBE: The tube sockets are located on the left side of the amplifier. They have five contacts which match the five pins on the 3-500 triode. Insert the tube into the socket making sure that the

pins align with the socket contacts. If the tube pins and socket contacts are not aligned, the amplifier will not function properly and damage to the tube may result. After you have properly inserted the tube into its socket, connect the parasitic suppressor choke coming from the top of the plate choke to the plate connector pin located in the top of the tube. The connector should snugly slide over the plate connector pin.

LINE VOLTAGE SELECTION POWER POWER BLOCK WIRING

Before performing any of the following installation procedures, make sure that the amplifier has not been plugged into the AC supply line.

Refer to the four Power Block Wiring Diagrams while reading this section. Locate the Line Voltage Power Block. It is located inside the just above the AC line Cord, and it contains 5 screw connection terminals. It also has black and white leads connected to it.

120 VAC: Two wire jumpers (J1 & J2) are connected to terminals. J1 is connected to terminals 1 & 4. J2 is connected to terminals 2 & 6. If there is a white wire connected to left side of terminal 5, remove it and connect it to left side of terminal 6. Also, if there is a black wire connected to the left side of terminal 2, remove it and connect it to the left side of terminal 1. Make sure all screws are tightened.

240 VAC: One wire jumper (J1) is connected to terminals. If a second Jumper was previously connected to the terminal block, you may discard it. J1 is connected to terminals 2 & 3. If there is a white wire connected to left side of terminal 5, remove it and connect it to left side of terminal 6. Also, if there is a black wire connected to the left side of terminal 2, remove it and connect it to the left side of terminal 1. Make sure all screws are tightened.

You are now ready to replace the amplifier's top cover. **The hot air exhaust holes should be located on the top left and the cooling air entry holes should be on the right side.** Align the mounting holes with the corresponding threaded inserts located on the chassis. You may also need to use an alignment tool such as an awl. You may need to lightly tap the top cover into place with your hand. The left and right sides of the top cover may need to be pushed inward as you place the mounting screws into place. Replace the nine 6-32 x 3/8 mounting screws and washers. Partially tighten each screw. When all nine screws have been inserted, tighten all the screws. **Double check to make sure that the cooling air entry holes are on the right side, and the hot exhaust air exit holes are located on the top left directly over the tube.**

RESHIPMENT INSTRUCTIONS

Use the original packaging if it is necessary to return the amplifier, transformer, or tube to QRO for servicing. The original shipping carton and the interior corner pads are designed to provide the necessary support for safe shipment or reshipment. If the original carton along with the internal packaging is not available, contact the factory and a new carton will be shipped to you at a nominal cost. Always insure the package for the full replacement value and ship via UPS ground service. **QRO Technologies, Inc. will not be responsible for any damage or loss during return shipment.**

INTRODUCTION

The QRO Model HF-1000 Linear Amplifier is a completely self-contained, grounded grid, linear amplifier. It is designed to operate at 1,000 watts PEP output on SSB, 850 watts on CW, and 500 watts on such high duty cycle emissions as RTTY, SSTV, and FM.

The HF-1000 is designed to be used with any transceiver which will deliver 100 watts or more output. It can be used with less driving power, but it will have a lower output.

A broad-band tuned input circuit for each band feeds the 3-500 triode tube which is connected in a grounded grid configuration.

An ALC circuit develops negative voltage that can be fed back to the transceiver to reduce its gain when the amplifier is overdriven.

The antenna transmit-receive (T/R) relay is normally actuated by relay contacts, or an electronic switch, in the transceiver to place the amplifier in the transmit mode. The relay contacts must be connected to ground. Operation problems will occur if the contacts have more than zero volts DC. A +15 VDC contact is provided for transceivers utilizing a + 15 VDC on transmit for T/R switching.

LOCATION

Do not operate the Amplifier in excessively warm locations or near heating vents or radiators. Be sure air can circulate freely around and through the Amplifier cabinet, and can provide an unobstructed air inlet for the internal cooling fan. Do not place any books, magazines, manuals, or equipment that will impede the free flow of air near the sides and the hot air exhaust holes located on the top of the cabinet.

The internal fan allows an air flow of approximately 50 CFM. Do not use an external auxiliary cooling fan with less than 50 CFM capacity. The exhaust air becomes quite warm at high power levels. Do not position any heat-sensitive objects in the exhaust airflow path.

AC LINE POWER CONSIDERATIONS

Before operating the amplifier, verify that the AC Voltage Power Block located inside the amplifier has been wired correctly for the local AC supply you will be using. See the Voltage Power Block Wiring Diagram for the correct wiring. **Make sure the AC line cord has been disconnect and filter capacitors have no charge on them before removing the top cover.**

Verify that the rating of the line fuses located in the rear panel fuse holders is suitable for the AC line voltage you will be using. The fuse should be the glass cartridge slo-blow type. The rating should be either of the following:

100/120 VAC	20 Ampere
200/240 VAC	10 Ampere

Use only AC power outlets having a protective ground for connection to the amplifier. **DO NOT USE 2 conductor extension cords or 3 prong to 2 prong adapters that do not provide a protective**

ground connection. Connection of the power cord to the power outlet must be made in accordance with the following standard color code:

	American	European
Live	Black	Brown
Neutral	White	Blue
Ground (Earth)	Green	Green/Yellow

Use the following NEMA plug configurations according to the corresponding AC line voltage:

100/110 VAC 20 Ampere 5-15P
200/240 VAC 10 Ampere 6-15P or 6-20P

Due to the power involved, this Amplifier should have its own 240 VAC electric service line. This line should have three 12-gauge conductors, and 10 ampere fuses in each "hot" wire. If a single 240 VAC line serves the entire station, make an effort to connect your equipment so the load is balanced between the two "hot" wires.

If you have only 120 VAC available, use a separate line made up of 10 gauge conductors and 20 ampere fuses in each leg of the circuit.

DO NOT use this Amplifier at its full ratings on a regular house wiring circuit, as the ratings of the wire will almost certainly be exceeded.

Avoid excessively long runs of wire between your service entrance and the Amplifier. A heavy flow of current in such a line results in a voltage drop which can affect the performance of your equipment.

The plug on the power cord of your Amplifier, if wired for 120 VAC operation, is for standard 120 VAC outlets (NEMA 5-15P). If the Amplifier is wired for 240 VAC operation, no plug is supplied with the line cord. Use a plug that matches your 240 VAC receptacle (NEMA 6-15P or 6-20P). Your power connection must conform to section 210-21 (b) of the National Electric Code, which reads, in part:

"Receptacles connected to circuits having different voltage, frequencies, or types of current (AC or DC) on the same premises shall be of such circuits are not interchangeable."

When you install a new plug, make sure it is connected according to your local electrical code. Keep in mind that the green line cord wire is connected to the Amplifier chassis.

ANTENNA

The output circuit of the Amplifier is designed to be connected to an unbalanced transmission line that has a 50 ohm characteristic impedance. Lines of other characteristic impedance may be used providing the SWR (standing-wave-ratio) does not exceed 2:1. In addition, the built-in wattmeter is only accurate at 50 ohms.

The RF OUT connector is a UHF type SO-239. You will need a mating PL-259 plug for your transmission line.

Use coaxial cables like RG-8U, RF-11U, or similar types, for the transmission line. Due to the power level, the smaller types RG-58U, RG-8X, and RG59/U are not recommended.

The "A.R.R.L. Antenna Book" is readily available and includes comprehensive reference work on transmission lines and antennas. Other similar handbooks for the radio amateur are offered for sale and can often be found in a public library.

GROUNDING

Connect a good earth or water pipe ground to the ground post on the rear of the Amplifier. Use the heaviest and shortest connection possible. Before you use a water pipe ground, inspect the connections around your water meter and make sure that no plastic or rubber hose connections are used. These connections interrupt the continuity to the water supply line. Install a jumper around any insulating water connectors you may find. Use heavy copper wire and pipe clamps. It is best to ground all equipment to one point at the operating position and then ground this point as described above.

EQUIPMENT INTERCONNECTIONS

Interconnection between the Amplifier and a typical transceiver is shown in the "Interconnection Diagram" located inside your transceiver owners manual. Many brands of equipment usually follow the same general pattern. Please refer to this diagram plus the amplifier's Rear Panel Pictorial while reading the following:

RF IN Connect this socket to the RF output connector of your transceiver.

RF OUT Connect this socket to the cable coming from your antenna.

Note: Use shielded cable, such as audio-type cable, for the following connections.

KEY XMT Connect this socket to the Relay socket or keying contact on your transceiver. This connector requires contacts that are normally open in the receive mode and closed in the transmit mode. ***This contact sinks 12 VDC to ground at 80 mA.***

+15 V XMT If your transceiver has a provision for +15 VDC on transmit for keying external devices, such as linear amplifiers, connect this socket to the appropriate socket on your transceiver.

Note: If your transceiver has neither of the above keying methods, you will have to use some other means. For instance, you could use a shorted RCA phono plug by placing it in the Key XMT socket. Then, you would have to manually turn off and on the Operate/Standby switch located on the front panel.

ALC OUTPUT Connect this socket to the ALC input of your transceiver. A 0 to 20 V negative ALC voltage is present at this socket. Refer to your transceiver manual for proper connection information. Whenever the Amplifier is overdriven, the ALC circuitry creates a negative voltage that is fed back to the transceiver to reduce its gain and help prevent "flat-topping". Protective circuitry of this nature is a valuable circuit element, but it is not a substitute for proper adjustment of the transceiver drive.

SAFETY INTERLOCK SWITCH

While the Amplifier's top cover is in place, the interlock switch closes to allow AC line voltage to reach the power transformer. When the top cover is removed, the interlock switch opens and disconnects the line voltage. This does not discharge the bank of power supply filter capacitors. Be sure to allow the filter capacitors to discharge before you touch anything inside the Amplifier. You can select the High Voltage function of the Multimeter to check the high voltage potential.

DRIVING POWER

This Amplifier is designed to operate at full ratings when it is driven by a transceiver that has approximately 100 watts of RF output. You can use a transceiver that has lower output power, but the Amplifier's output will be less. If you use a transceiver that delivers more than 100 watts, carefully adjust the driving power to avoid "overdrive" and the creation of spurious signals, which create needless interference to other operators.

IMPORTANT: In no case should you advance the power output control of your transceiver beyond the point where the Amplifier's power output indication ceases to increase. If you turn the control past this point, nonlinear operation may occur.

TUBE

It is not abnormal for the tube to show a dull red color. But if the plate shows a bright orange or yellow color, immediately investigate the tuning and drive conditions and make any necessary corrections. After prolonged operation, let the Amplifier run for several minutes without drive applied so the fan will cool the tubes before you turn the Amplifier off.

READING THE METERS

Refer to Front Panel Pictorial while you read the following information:

Multimeter: The Multimeter switch on the front panel of the Amplifier selects the right-hand meter functions. Read the meter scale which corresponds to the setting of the Multimeter switch as shown in Table A.

Grid Meter: The left-hand meter always indicates grid current between 0 and 300 milliamperes. Each Division indicates 10 milliamperes.

Table A

Multimeter Switch Position	Measures	Scale Indication
Plate Voltage (PV)	Plate Voltage	Center scale indicates 0 to 3500 volts (normal operating range is 2700 to 3400 volts) Each division represents 100 volts.

Plate Current (IP)	Plate Current	Top meter scale indicates 0 to 1400 milliamperes. Each division represents 40 milliamperes.
Power Output (PO)	Peak RF Power	Bottom meter scale indicates 0 to 2000 (PEP) watts. Does not measure average or RMS power. It measures only SSB voice peak power.
ALC	ALC Detector	Indicates relative ALC Output

TUNE-UP PROCEDURE

Please refer to the Front Panel Pictorial while reading the following.

The current and voltage figures given in this section are approximate. Actual indications will vary at each installation with such factors as line voltage, transceiver drive, and load impedance.

The following procedure for tuning the Amplifier should only take a few seconds after you go through it a few times. Note the Tune control position and the Load control position so you can preset it the next time you use a particular band and frequency.

For your convenience, the following chart shows typical settings:

TUNE-UP TABLE (50 Ohm Resistive Load, 240 VAC)

Serial No. 5475

Freq (Mhz)	Band	Drive	Tune Control	Load Control	Plate Voltage	Plate Current	Grid Current	Power Output
1.80	160	100w	62	66	2500	500mA	150mA	900W
1.90	160	100w	26	64	2500	500mA	150mA	900W
3.60	80	100w	60	82	2500	500mA	150mA	1000W
3.90	80	100w	36	70	2500	500mA	150mA	1000W
7.20	40	100w	90	52	2500	500mA	150mA	1000W
14.20	20	100w	38	28	2500	500mA	150mA	1000W
18.10	17	100w	36	24	2500	500mA	150mA	950W
21.30	15	100w	20	22	2500	500mA	150mA	700W
24.90	12	100w	14	16	2500	500mA	150mA	900W
28.50	10	100w	10	16	2500	500mA	150mA	800W

CW, RTTY, SSTV Procedure

Make sure you have the Amplifier connected as described in the Equipment Interconnections Section. **IMPORTANT:** Before you proceed, make sure you have a dummy load or an appropriate antenna is connected to the Amplifier RF Output connector.

1. Preset the Amplifier controls as follows:

On/Off	Off
Operate/Standby	Standby
Multimeter	PV
ALC Adjust	Minimum (Fully counter clockwise)

2. Plug the line cord into a proper AC outlet.

3. Set the On/Off switch to On. The meter lamps should light and the fan should run. The red power indicator LED should also be lite. The 0 to 3500 V scale on the Multimeter should indicate approximately 3000 to 3400 volts.

4. Make sure your transceiver has been turned on and its drive level control has been set to minimum.

5. Turn the Band Switch to the same band as you have selected on the transceiver. Then preset the Tune Control and the Load Control to the positions indicated in the above chart for the band you have selected.

6. With the transceiver drive still at minimum, set the Multimeter Switch to Plate Current (IP). The 0 to 1400 ma scale should indicate zero. Now set the Operate/Standby switch to the Operate position.

7. Key the transceiver (with no drive applied) and observe the plate current on the 0 to 1400 ma scale. The plate current should read 80 to 120 ma.

8. Apply only enough drive to obtain 50 ma of **grid current** and no more than 400 ma of **plate current**. Now tune the Tune Control for maximum grid current. Unkey the transceiver. **NOTE:** It is normal for the plate current to dip (be reduced) when you have maximum grid current. **If the grid current goes over 100 ma, immediately reduce the drive.**

9. Again key your transceiver and observe the peak RF watts on your wattmeter. Adjust the Tune Control and Load Control for maximum output on your wattmeter. This is accomplished by going back and forth between each control.

10. Increase the transceiver drive until you obtain 125 ma of grid current. Now readjust the Tune Control and Load Control for maximum output. The grid current should decrease.

11. Increase the transceiver drive for 200 ma of grid current. Then readjust the Tune Control and Load Control for maximum output power. The output should now be around 800 watts with 90 - 100 watts of transceiver drive power.

12. Apply only enough drive to indicate either 800 watts of output power, or 200 ma of grid current. Repeat the Tune Control and Load Control. Note: The grid current, plate current. and output

power must not exceed the following limits:

Grid current	200 ma
Plate current	620 ma
Output Power	900 watts

13. When you operate in CW, reduce the drive power until the plate current is 550 ma or less. Also when operating RTTY or SSTV, reduce the drive power until the plate current is 300 ma or less.

The Amplifier is now fully loaded for operation on CW, RTTY, or SSTV.

SSB Procedure

1. Tune up the Amplifier as described for CW operation.
2. Advance the transceiver drive and audio levels so that the modulation crest does not exceed 400 ma of plate current, 100 ma of grid current, or 1,000 watts of PEP output.

USING THE FRONT PANEL ALC CONTROL TO ADJUST AMPLIFIER OUTPUT POWER.

You may want to utilize an alternative to adjusting the drive power at the transceiver. The Front Panel ALC Adjustment Control allows you to adjust the ALC for the amount of output power you desire. Using this procedure, you would set the ALC Control to minimum (fully counter-clockwise). Tune the amplifier for maximum output. Then advance the ALC Control (clockwise) for the amount of output power you want. The ALC circuit of the amplifier supplies negative feedback voltage to the transceiver which reduces the amount of drive coming into the amplifier. **Only use this feature after your Amplifier has been properly tuned.**

TUNED INPUT ADJUSTMENTS

Please refer to the Rear Panel Pictorial while reading the following.

Your Amplifier's tuned input circuits have been factory preset for the optimum match. However before your initial operation, you may want to check the tuned input circuits for each band to see if it has the proper match. A nominal match will show no more than 10 watts reflected with 100 watts of drive applied.

To check the tuned input match, follow the following procedure:

1. Place a wattmeter in line between the transceiver and the Amplifier which reads reflected RF power.
2. Select one of the HF bands on your transceiver, and then select the corresponding band on the amplifier.
3. Place the amplifier in the Operate mode, and tune the amplifier according to the tune up procedure.

4. Observe the reflect power between the transceiver and the amplifier. If it exceeds 5 watts, adjust the corresponding mica trimmer capacitor located on the rear panel. This trimmer capacitor is located through the corresponding rear panel access hole in the area marked Tuned Input Adjustments. Use only a non-conductive flat blade adjustment tool.
5. Advance the mica trimmer capacitor's adjustment screw either clockwise or counter-clockwise and observe the reflected power indication on the watt meter. Adjust for minimum reflected power.
6. Repeat this procedure for each band.

PERIODIC MAINTENANCE

Make sure the Amplifier has been disconnected for the AC power source and the high voltage filter capacitors have bleed down to zero.

Remove the top cover from the Amplifier at least once a year and remove the dust. Dust accumulation can help cause the variable capacitors to arc between plates. Use the blower connection on a vacuum cleaner or a soft bristle brush.

Also, remove the tube from its socket and check to see if any tarnish buildup has developed on the tube socket contacts. If so, use a Q Tip and Tarn-X solution, and clean each of the socket contacts.

TROUBLESHOOTING CHART

The following charts lists specific difficulties that could occur in your Linear Amplifier. Several possible causes may be listed for each difficulty. Refer to the Printed Circuit Board diagrams (PCB) and the Schematic Diagrams to locate and identify the parts listed in this chart. If a particular part is mentioned as a possible cause, check that part and other components connected to it to see if they are defective. **AS ALWAYS, BE SURE THE AMPLIFIER POWER CORD HAS BEEN REMOVED FROM THE AC LINE RECEPTACLE AND THE HIGH VOLTAGE FILTER CAPACITORS HAVE BLED DOWN TO ZERO VOLTS BEFORE REMOVING THE TOP COVER FOR YOUR INSPECTION.**

TROUBLESHOOTING CHART

DIFFICULTY	POSSIBLE CAUSE
No AC power	<ol style="list-style-type: none"> 1. Fuse F1 or F2 rear panel 2. Jumpers missing on Terminal Block TB1 3. Transformer T1 4. On/Off Switch SW2A or SW2B 5. Interlock Safety Switch SW1 6. Step Start Relay K1 or related circuitry
Multimeter inoperative in High Voltage Function	<ol style="list-style-type: none"> 1. Resistors R301, R302, R303, R304, High Voltage PCB-110 2. Multimeter Switch SW401A or SW401B Meter Switch PCB-510 3. M-2 Multimeter
Multimeter inoperative in Plate Current Function	<ol style="list-style-type: none"> 1. Resistors R308 - R310 LV & Bias PCB-260 2. Switch SW401A&B Meter Switch PCB-510 3. M-2 Multimeter
Multimeter inoperative in Power Output Function	<ol style="list-style-type: none"> 1. Components on ALC/Power PCB-610 <ol style="list-style-type: none"> a. Capacitors C601 -C603, C604, C608, C609 b. Diodes D601, D602 c. Resistors R601, R605, R606 d. POT R605 e. Transistor Q601 2. Switch SW401A&B Meter Switch PCB-510 3. M-2 Multimeter 4. +12V Regulated Power Supply on LV & Bias PCB-260
Multimeter inoperative in ALC Function	<ol style="list-style-type: none"> 1. Components on ALC/Power PCB-610 <ol style="list-style-type: none"> a. Capacitors C606 & C607 b. Resistors R602 & R603 c. Diodes D603 & D604 2. POT R13 on front panel 3. Resistor R312 LV & Bias PCB-260 4. Switch SW401A&B Meter Switch PCB-510 5. M-2 Multimeter
Plate idle current over 80 ma or does not read zero in standby mode	<ol style="list-style-type: none"> 1. Components on LV & Bias PCB-260 <ol style="list-style-type: none"> a. Transistor Q302 b. Diodes D303 - D310 c. Resistor R304 d. Transient Voltage Suppressor TSD301 e. Capacitor C302 f. Resistors R308 - R310

No Plate idle current	<ol style="list-style-type: none"> 1. Components on LV & Bias PCB-260 <ol style="list-style-type: none"> a. Transistor Q302 b. Diodes D303 - D310, D311 c. Resistor R301 &R304 d. Transient Voltage Suppressor TSD301 e. Capacitor C302 f. Resistors R308 - R310 g. Relay K301A
No Plate Voltage or only 50% Plate Voltage	<ol style="list-style-type: none"> 1. Components on HV Capacitor PCB-105 <ol style="list-style-type: none"> a. Capacitors C201 - C208 b. Resistors R201 - R208 2. Components on HV Diode PCB-110 <ol style="list-style-type: none"> a. Diodes D101 - D110 b. Capacitors C101 - C110 c. Resistor R209
No Plate Idle current cut-off when amplifier is not keyed or is in standby mode	<ol style="list-style-type: none"> 1. Components on LV & Bias PCB-260 <ol style="list-style-type: none"> a. Transistor Q302 b. Diodes D303 - D310, D311 c. Resistor R301 &R304 d. Transient Voltage Suppressor TSD301 e. Capacitor C302 f. Resistors R307 - R310 g. Relay K301A 2. Components on HV Diode PCB-110 <ol style="list-style-type: none"> a. Resistors R301 - R304
Meter Lamps do not light	<ol style="list-style-type: none"> 1. Components on LV & Bias PCB-260 <ol style="list-style-type: none"> a. Fuse F302 b. Bridge Rectifier D311 c. Capacitors C303 - C305 d. +12v Regulator Q303 2. Associated +12v Supply wiring 3. Meter Lamps PL1 - PL4 Meter Switch PCB-510
No Grid Current Meter Indication with Plate Current Indication OK	<ol style="list-style-type: none"> 1. Components on LV & Bias PCB-260 <ol style="list-style-type: none"> a. Resistor R311 b. Capacitor C306 2. Grid Meter M-1
Amplifier will not key when transceiver is keyed to transmit	<ol style="list-style-type: none"> 1. Components on LV & Bias PCB-260 <ol style="list-style-type: none"> a. Fuse F301 b. Bridge Rectifier D302 c. Capacitor C301 2. Components on RF I/O Switching PCB-350 3. Operate/Standby SW4 Front Panel 4. Improper keyline connection between transceiver and amplifier

ALC Inoperative	<ol style="list-style-type: none"> 1. Improper connection between transceiver and amplifier 2. POT R13 (ALC Adjust) on front panel
No RF Output	<ol style="list-style-type: none"> 1. Improper connections between transceiver, amplifier, and antenna 2. Transceiver and amplifier are set to different bands 3. Improper Tuned Input adjustment 4. Defective RF I/O Switching PCB-350 5. Defective RF Output T/R Relay RY1 6. Defective Band Switch SW3A, SW3B 7. Defective Tuned Input Band Switch SW3C
Tuned Input can not be adjusted for proper match	<ol style="list-style-type: none"> 1. Defective Component Tuned Input PCB-450 2. Defective Tuned Input Band Switch SW3C 3. Components on LV & Bias PCB-260 <ol style="list-style-type: none"> a. Fuse F302 b. Bridge Rectifier D311 c. Capacitors C303 - C305 d. +12v Regulator Q303 4. Associated +12v Supply wiring 5. Transceiver and amplifier are set to different bands 6. Improper connections between transceiver, amplifier, and antenna
Red Power LED not functioning	<ol style="list-style-type: none"> 1. +12 VDC supply located on LV & Bias PCB-260 and related wiring 2. LED D1 defective
Green Transmit LED not	<ol style="list-style-type: none"> 1. +12 VDC supply located on LV & Bias PCB-260 and related wiring 2. LED D2 defective 3. Relay K301 and related keying circuitry

CIRCUIT DESCRIPTIONS

Refer to the Appropriate Schematic Diagrams and PCB Layouts while you read the following paragraphs.

POWER SUPPLY

Power transformer T1 supplies the power required to operate the Linear Amplifier. A dual-winding primary allows the amplifier to be operated from 100/120 VAC or 200/240VAC. These winding are connected in parallel for 100/120 VAC operation or in series for 200/240 VAC operation. Two 10 ampere or two 20 ampere fuses protect the transformer against overload depending on the

primary voltage. Capacitors C11 & C12 provide AC line bypassing.

This amplifier uses a special combination safety interlock/step-start circuit. Interlock switch SW1, On/OFF power switch SW2A&B must be closed before power is supplied to the primary of transformer T1. Relay K-1 provides a step-start when the amplifier is switched on. Components C12, R10, D10 provide the time delay to minimize the inrush current. Resistors R11 & R12 limit the inrush current while the delay circuit cycles. After a 1 to 2 second delay the contacts on relay K-1 close allowing the full current to be applied to the primary of T-1.

Terminal Block TB1 allows for the selection of the line voltage to be used. See the Terminal Block Wiring Diagram for the correct wiring. Cooling Fan B1 is provided 100/120 VAC by connection across only one of the primary windings at TB1. B1 always operates on 100/120 VAC regardless of which AC line voltage is used.

The secondary windings of T1 provides the following secondary voltages:

5.6 VAC	Tube filament
12.0 VAC	+12 VDC Power Supply
110 VAC	RF I/O Switching Supply
1200 VAC	Plate Voltage Supply

PLATE VOLTAGE

The 1200 VAC output of T1 is connected to a full-wave voltage doubler circuit consisting of the components on HV Capacitor PCB-105 and HV Diode PCB-110. Diodes D101 - D110 rectify the secondary AC voltage and capacitors C201 - C208 filter this voltage. Capacitors C101 - C110 are connected across the diodes to protect them against transients. Resistors R201 - R208 are connected across the filter capacitors to equalize the voltage drop across each capacitor. These resistors also act as bleeder resistors for the filter capacitors to discharge them when the amplifier is turned off. One of the red 1200 VAC secondary lead is connected to the junction of C204 & C205, and the other red 1200 VAC secondary lead is connected to the junction of D105 & D106. During the AC line cycle when the lead at C204 & C205 junction is positive, diodes D101 - D105 conduct and capacitors C201 - C204 are charged. During the other half of the AC line cycle, the red lead connected to the junction of D105 & D106 becomes positive. Capacitors C205 - C208 charge and Diodes D106 - D110 conduct. The two capacitor strings are in series across the load, and the voltages of each capacitor group add together. The capacitor bank charges to twice the peak voltage of the 1200 VAC secondary voltage ($1200 \text{ VAC} \times 1.414 \times 2 = 3,393 \text{ VDC}$). Resistor R209 is a protection resistor connected in series with the Plate Voltage Circuit. If a short develops, this resistor prevents the B- from rising to the B+ potential. Thus providing protection for all the components within the B+ circuit including the 3-500 triode. Resistors R301 - R304 are discussed under Metering Circuits.

TUBE FILAMENT AND BIAS

The 5.2 VAC secondary windings on T1 secondary supplies 15 amperes for the amplifier's tube filament. The filament voltage is fed to tube V1 through RFC2 which is a bifilar wound coil on a ferrite rod core. This coil forms a choke to raise the tube filaments above RF ground potential so that the driving voltage is not short circuited. Capacitors C59 & C60 keep RF out of the filament supply circuit. In the transmit mode, the center tap of the filament winding (5.2 VAC) is connected to ground through the bias circuit located on the LV & Bias PCB-260. This circuit consists of

transistor Q302, transient suppressor TSD301, bypass capacitor C302, Resistors R304 & R311, Relay K301A, Diodes D303 - D310. This bias circuit develops +11 VDC operating bias for tube V1 and limits the idling plate current. In Standby (receive) Mode, a +24 VDC voltage is formed across resistor R307. This voltage is applied to the tube filaments, in addition to the AC voltage, to bias the tube beyond cut off so that no plate current flows.

12 VAC SUPPLY

The 12 VAC secondary winding of T1 supplies the voltage for the +12 VDC supply circuit located on the LV & Bias PCB-260.

110 VAC ISOLATION SUPPLY

The 110 VAC secondary winding of T1 provides an isolated supply voltage for the +110 VDC power supply located on the LV & Bias PCB-260.

RF INPUT CIRCUITS

When the amplifier is in the Standby Mode (receive), Relay RY1 and Relay RY2 (located on the RF I/O Switching PCB) are in their normally open state. Thus, RF energy supplied from the transceiver passes through RF Input Connector (J2), RY2, RY1, and RF Output Connector (J1) to the antenna. The amplifier has been bypassed. Capacitors C70 & C71 tune the mismatch that occurs with the relay contacts located inside RY1 & RY2.

When the amplifier has been keyed (Transmit Mode), RY2 closes and the RF energy supplied by the transceiver passes through RY2's closed contacts to the Tuned Input PCB-450. The signal then passes through the selected input matching network and then on to coupling capacitors C57 & C58 located at the tube filaments.

TUBE

The amplifier's tube is connected in a class AB 2 grounded grid circuit. RF driving power is applied to the filaments in the normal cathode driven configuration. As mentioned in the Filament & Bias Section, RFC2 holds the filaments above RF ground. Pins 2, 3, and 4 of the tube are internally connected together and are connected to ground. Parasitic choke PC1 is connected to the plate lead to suppress any VHF parasitic oscillations. The positive side of the power supply (B+) is connected to the tube's plate through RFC3 (Plate Choke). Capacitor C56 provides a low impedance path to ground for any RF energy that may get through RFC3. Capacitors C54 & C55 are DC blocking capacitors. They allow the RF signal to enter the output tank circuit, and they block the DC high voltage from entering the tank circuit. Fan B1 circulates cooling air around the tube.

RF OUTPUT CIRCUITS

The tuned output circuit of the Amplifier is a pi network in conjunction with a 4:1 transformer (L3). The pi circuit transforms the plate load impedance down to 200 ohms. The 4:1 transformer further transforms the 200 ohms down to 50 ohms. L3 has a secondary function to provide a broadband L coil for harmonic suppression. Band Switch SW3A progressively shorts out the unused portions of tank coils L1 & L2. The tank coil turns in use are tuned to resonance by Tune Capacitor C51A

& C51B. Load Capacitor C50 is tuned to complete the impedance match between the tube and the 4:1 transformer L3. Transformer L3 is then connected to RF Output connector J1 through T/R relay RY1. Tuning Capacitor C51A is switched in the tank circuit on 160 & 80 meters by one pole of Switch SW3B. Tuning capacitor C51B is solely used for 40 through 10 meters. This Tuning Capacitor switching is required because of the high internal capacitance of tube V1 at higher frequencies. Capacitor C52 provides additional capacitance for C51A on 80 & 160 meters. Capacitor C53 provides additional capacitance for C51A on 160 meters. If DC plate voltage should enter the tank circuit due to a short in either DC Blocking Capacitors C54 & C55, the DC voltage has a path to ground through the 4:1 Xfmr (L3). This will short-circuit the high voltage supply which will blow the AC line fuses. Also, DC plate will be prevented from entering the Antenna.

ALC CIRCUIT

ALC Adjust Control (R13) located on the front panel allows you to set the ALC threshold to match your Transceiver. Please refer to the Schematic and PCB drawing for the ALC/Power PCB-610. Capacitors C606 & C607 form a voltage divider that couples some of the RF driving voltage to Diodes D603 & D604. When the RF driving voltage exceeds the ALC threshold, the diodes rectify the negative half cycles. Capacitor C605 filters and bypasses this voltage, while resistor R603 provides isolation. The negative voltage appearing at ALC Output connector (J5) is coupled back to the transceiver to control its gain and reduce "flat topping" voice peaks due to overdrive. This allows you to control the output of your transceiver without reducing your transceiver's drive.

GRID METER CIRCUIT

Grid current meter M-1 provides an indication of grid current between 0 and 300 milliamperes. The grid current meter is connected in parallel with shunt resistor R311 located on the LV & Bias PCB-260. The grid return circuit is through bias diodes D303 -D310, transistor Q302 to the center tap of filament winding of power transformer T1. From this secondary winding, the grid current flows to the filaments via the tube filament circuit.

PV (PLATE VOLTAGE) MULTIMETER CIRCUIT

When you select this function, resistors R301 - R304 located on the HV Diode PCB-110 form a voltage divider to measure plate voltage. Resistors R302 - R304 form a series multiplier resistance for meter M-2 while resistor R301 forms a current shunt for the meter. Diodes D311 & D312 plus capacitor C307 provide M-2 with transient protection.

IP (PLATE CURRENT) MULTIMETER CIRCUIT

When you select this function, meter M2 indicates the plate current drawn by the tube between 0 and 1400 milliamperes. It is switched in parallel with resistors R308 - R310 located on the LV & Bias PCB-260. The voltage drop across these resistors is measured. The meter scale is calibrated to indicate the plate current by using the fixed parallel resistance values of R308 - R310 and the voltage across them. Diodes D313 & D314 plus capacitor C306 provide M-2 with transient protection.

PO (POWER OUTPUT) MULTIMETER CIRCUIT

Please refer to the Schematic and PCB drawing for the ALC/Power PCB-610. Capacitors C601, C602, and C603 form a RF voltage divider for a portion of the RF output voltage. This voltage is passed to a rectifier circuit consisting of diodes D601 & D602. Capacitor C604 provides filtering and bypassing. The resulting DC voltage then passes through resistor R601 through POT R604 and to the base of transistor Q601. Q601 and its associated components form an amplifier circuit. The resulting DC voltage then passes through multiplier resistor R606. From R606 the voltage goes through the Multimeter which is calibrated to indicate peak output power (PEP) between 0 and 2000 watts. POT R604 allows you to calibrate the Multimeter for this function.

ALC MULTIMETER CIRCUIT

When you select this function, a portion of the negative ALC voltage developed in the ALC/Power PCB-610, described earlier, passes through resistors R603 and R312 (LV & Bias PCB-260) to multiplier meter M-2.

RF I/O SWITCHING PCB AND BIAS RELAY SWITCHING CIRCUITS

All RF T/R relays (RY1 & RY2) and bias relay (K301) are connected in series in the amplifier keying circuit. The switching voltage is supplied by the +110 VDC 80 milliampere supply located on the LV & Bias PCB-260. This circuit includes bridge rectifier D302 & filter capacitor C301. The +160 VDC output is fed to voltage divider resistors R305 & R306 which are surface mounted on the chassis. +110 VDC keying voltage is dropped across resistor R306 and fed back to R301 and K301 located on the LV & Bias PCB. 12 volts is dropped across relay K301 and resistor R301. The remaining +98 VDC is passed to RY1 and R601 located on the RF I/O Switching PCB-350. 24 volts is dropped across R601 and RY1. 12 VDC is then dropped across RY2 and R603. The remaining +62 VDC is dropped across resistor R604. Capacitor C601 and resistors R601 & R602 plus diode D602 form a break make delay circuit for RY1 & RY2. This helps to make the proper latching and unlatching sequence for relays K301, RY1, and RY2. Transistor Q601 plus associated components form a electronic switch to key the Amplifier utilizing +15 VDC on transmit supplied by the transceiver through connector J4. The Amplifier can also be keyed by sinking the 80 milliamperes to ground through connector J3 and the transceiver's keying relay. The Operate/Standby Switch SW4 located on the front panel must be closed for the keying circuit to work. Otherwise the amplifier will be bypassed.

TUNED INPUT CIRCUITS

The eight matching circuits contained on the Tuned Input PCB-450 provide a Q of 2. This Q allows for sufficient bandwidth. The matching network for each band consists of a L-C-L "T" circuit. Mica trimmer capacitors C705 - C712 provide a means to make adjustments.

The appropriate input circuit is selected by the Tuned Input Band Selector Switch SW3C. SW3C provides +12 VDC to the corresponding relay coil (K701 - K708) which closes the relay contacts. The RF Input signal supplied by relay RY2 enters the selected matching circuit. It then leaves the matching circuit and goes to the filament of V1 through coupling capacitors C57 & C58.

ADDENDUM # 1

POWER BLOCK WIRING

QRD HF-1000/2000
POWER BLOCK
WIRING DIAGRAM

120 VAC

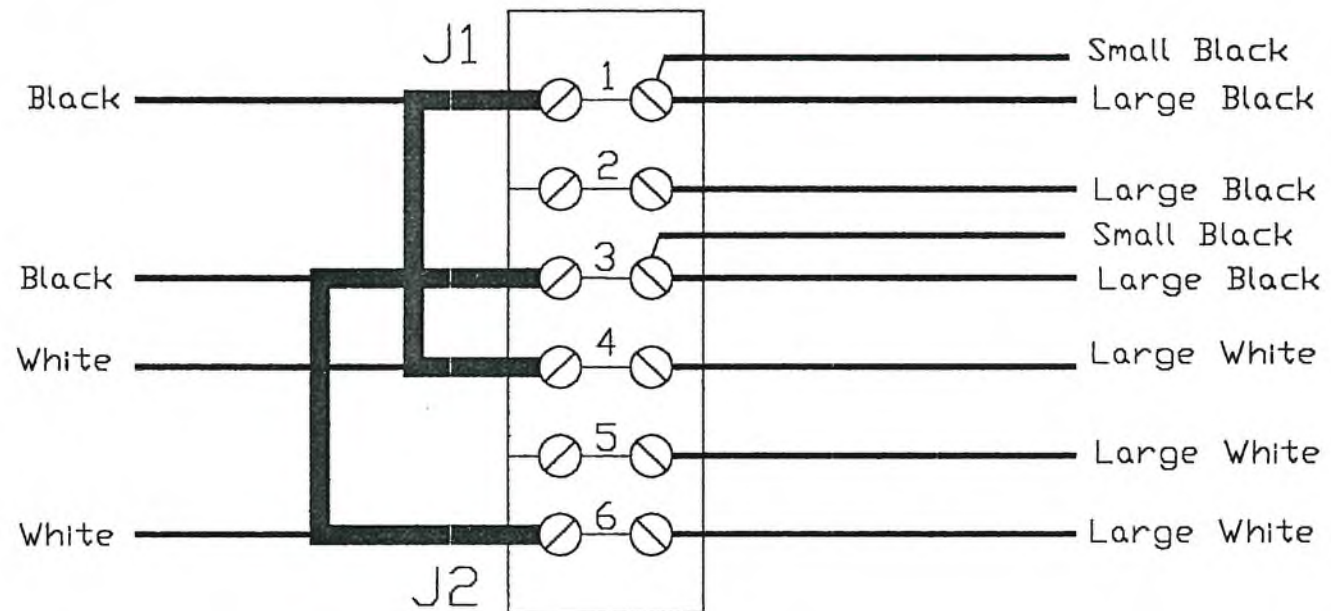

QR0 HF-1000/2000
POWER BLOCK
WIRING DIAGRAM

240 VAC

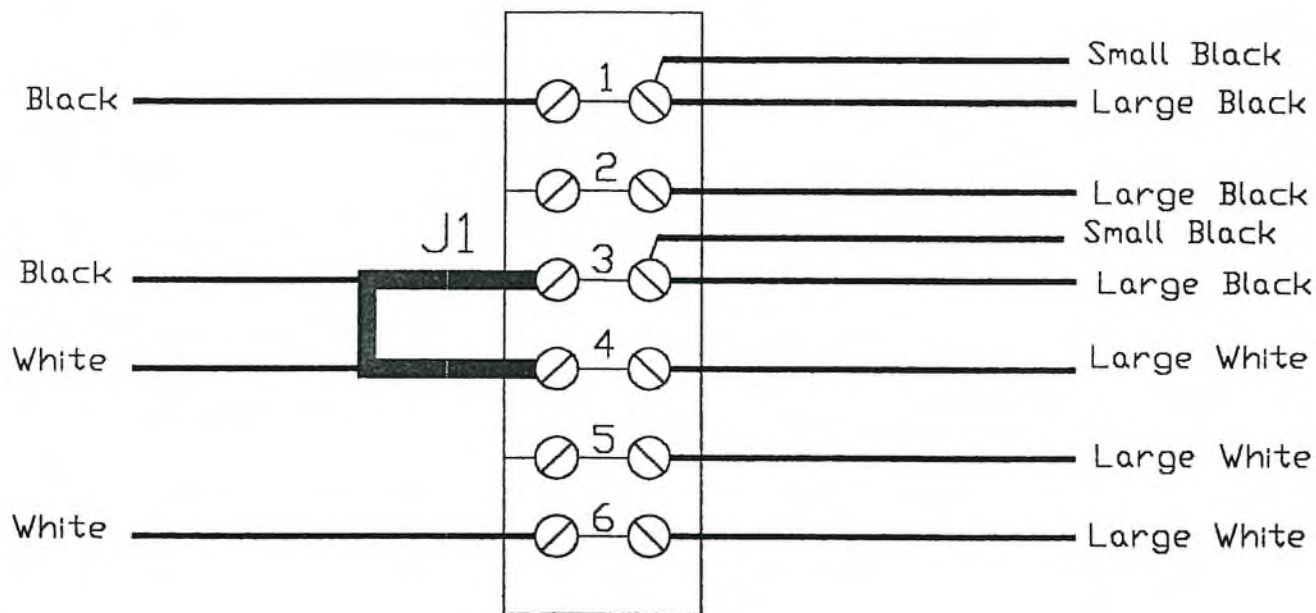

ADDENDUM # 2

SCHEMATICS

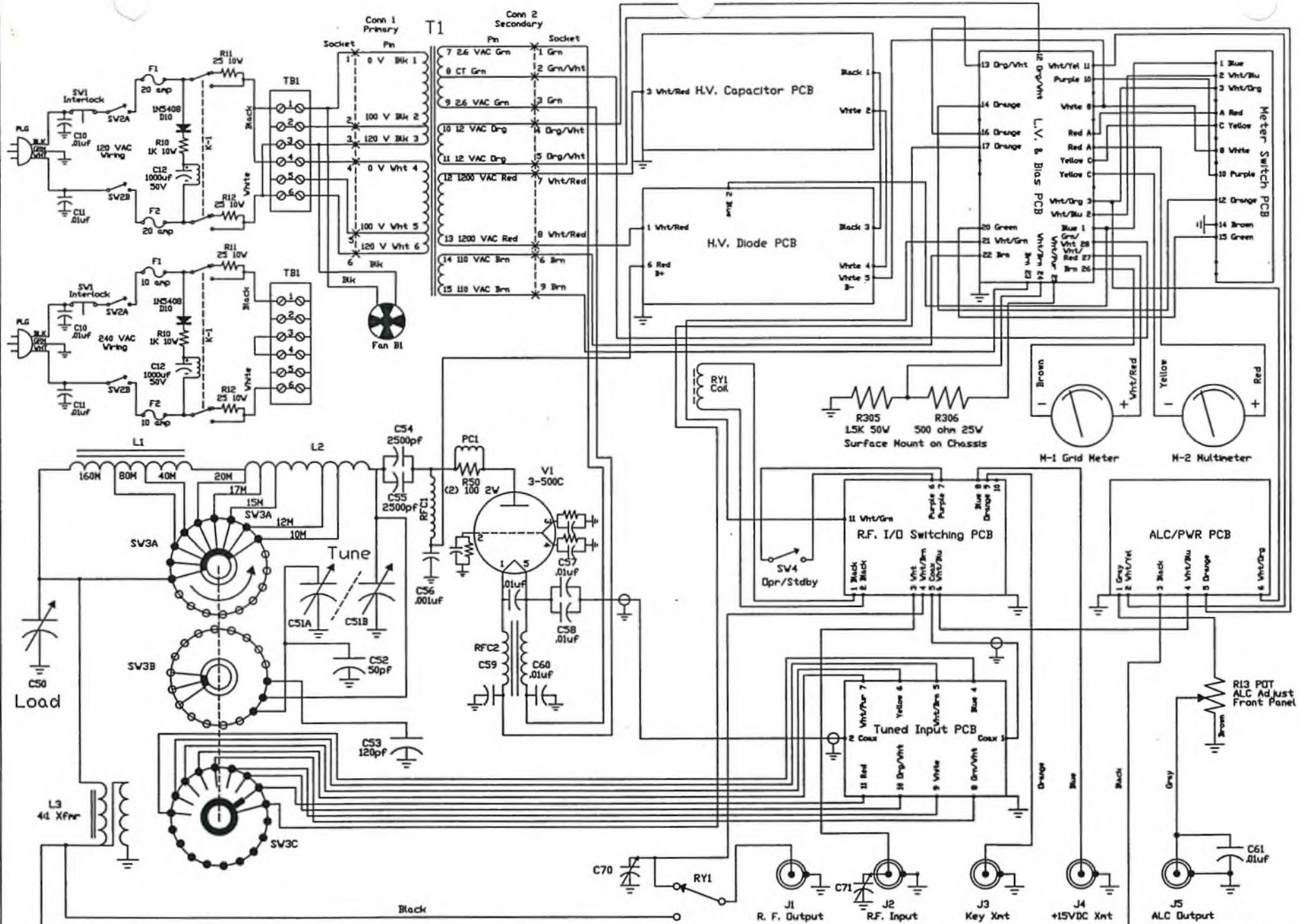

QRD TECHNOLOGIES, INC.
 Model HF-1000
 Schematic Diagram
 Ray W. Conlin
 January 13, 1995
 Rev. 2: 11/04/95

- From # 1 LV & Bias 1
PCB Blue
- From # 2 LV & Bias 2
PCB Wht/Blu
- From # 3 LV & Bias 3
PCB Wht/Drg
- From # A LV & Bias A
PCB Red
- From # C LV & Bias C
PCB Yellow
- From # 8 LV & Bias 8
PCB White
- From # 10 LV & Bias 10
PCB Purple
- To Chassis Grnd 14
Brown
- From # 14 LV & Bias 12
PCB Orange
- From # 20 LV & Bias 15
PCB Green

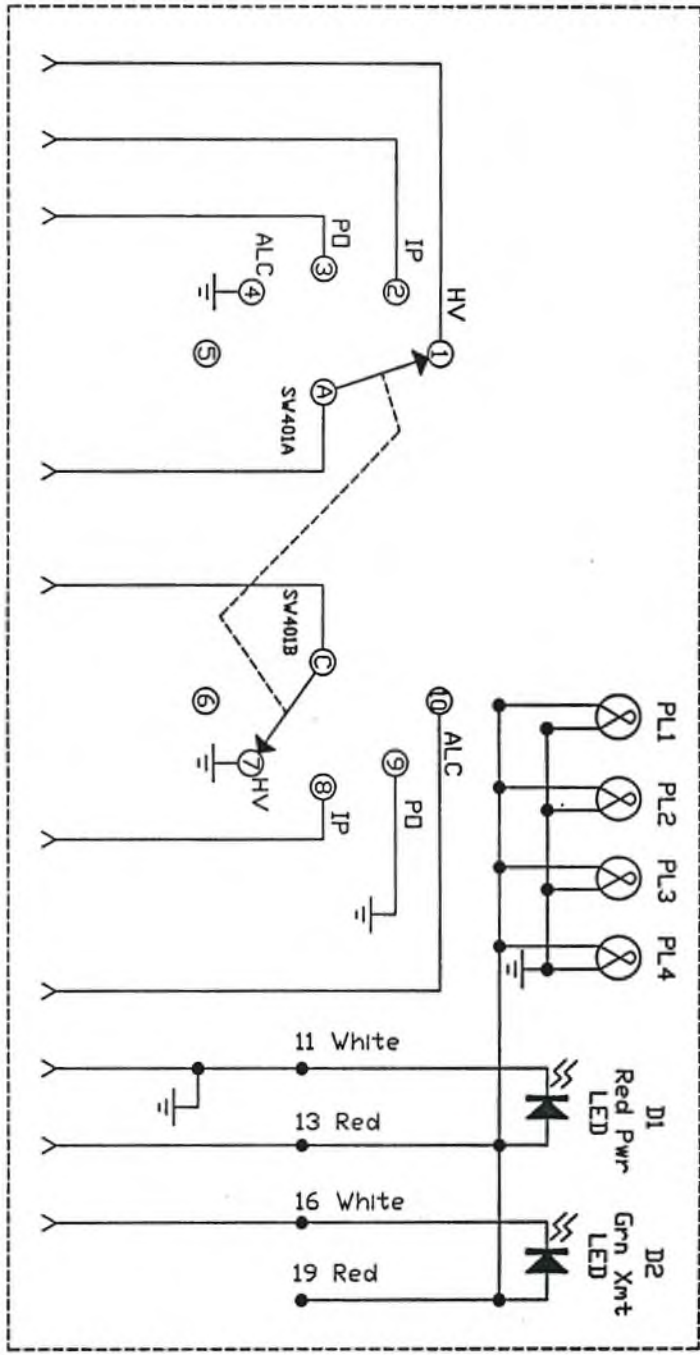

QRD Technologies, Inc.
 Meter Switch PCB
 Part No. PCB-510
 Ray W. Connin
 December 28, 1994
 Rev. 03/07/95

From #21 LV
& Bias PCB
Wht/Grn

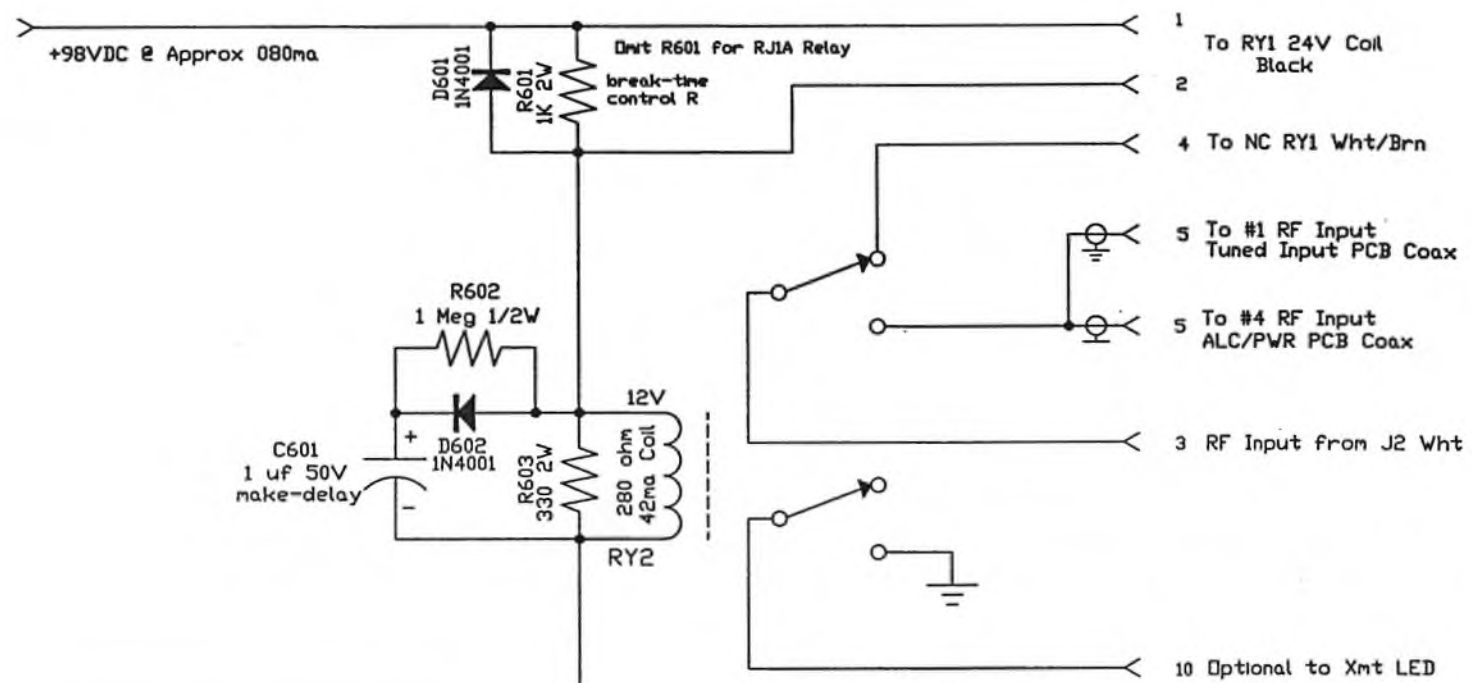

To Dpr/Stdby 6
Switch
Purple 7

Apply +8V to +15V
for Tx, 0V for Rx

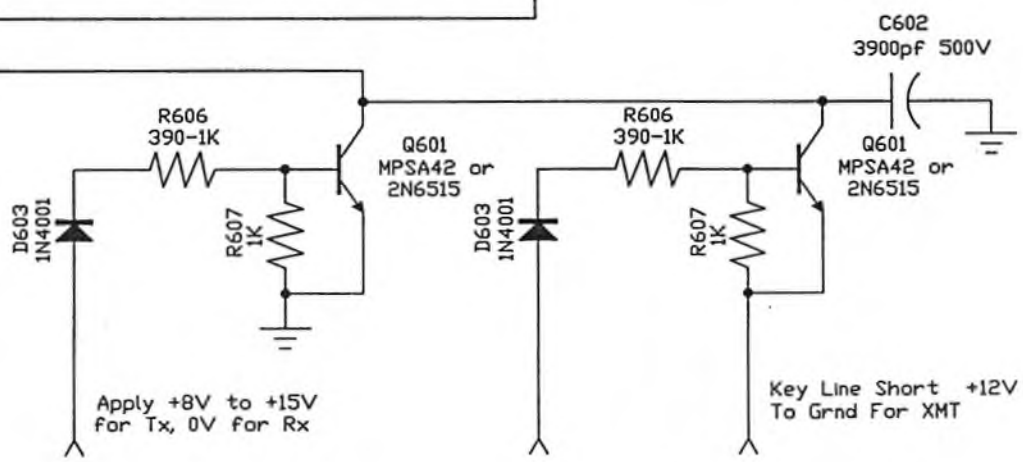

8
From J4
Blue

9
From +12V Reg
Orange

10
To J3
Org/Wht

QRD Technologies, Inc.
RF In/Out Switching PCB
Part No. PCB-350
Ray W. Connin
November 12, 1994
Rev. 2: 01/19/97

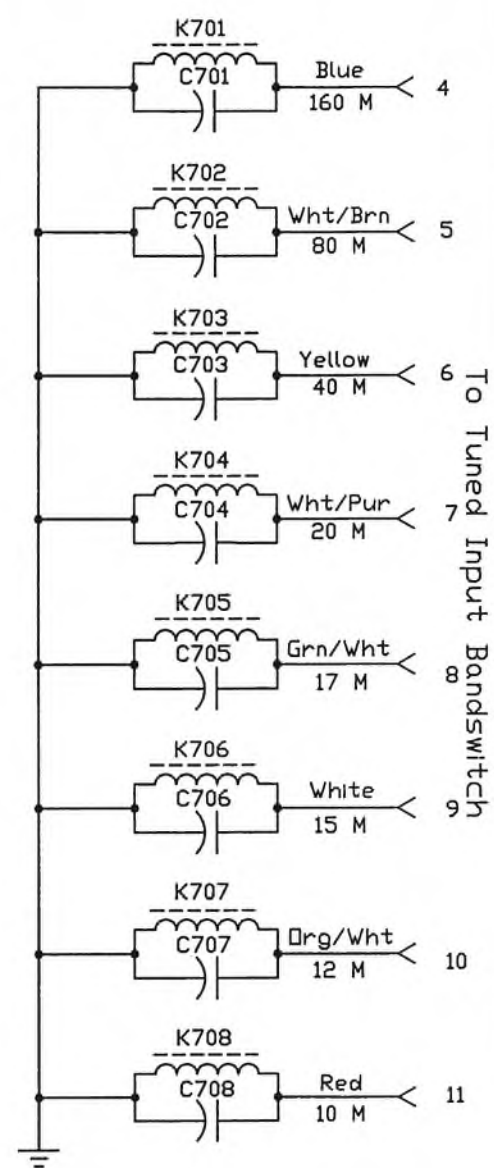
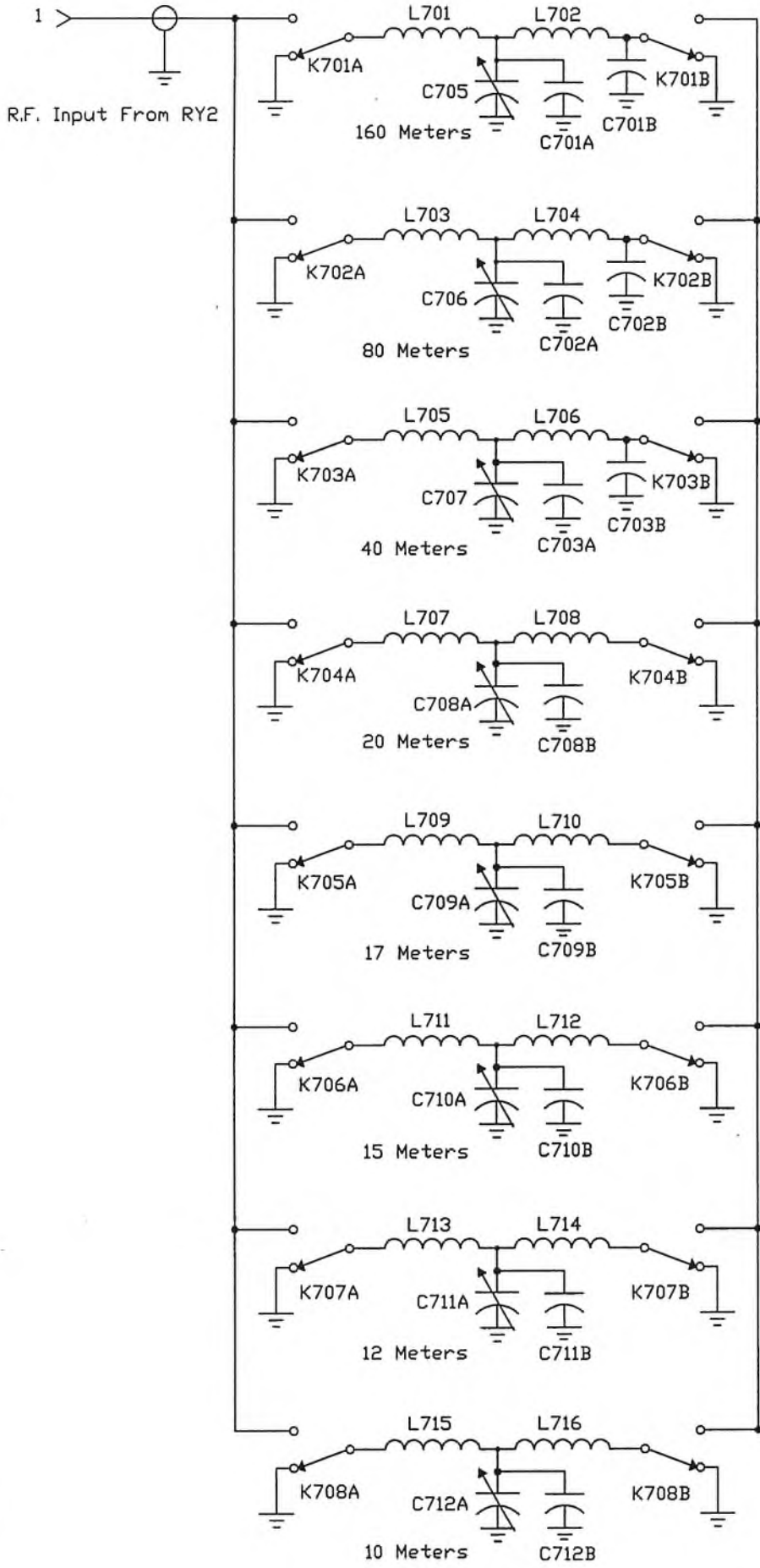

Note: C705-C712 25pf - 150pf
 L701 - L706 T-68-2 Core
 L707 - L716 T-68-6 Core

2 R.F. Output to V1
 Cathode/Filament

QRD Technologies, Inc.
 Part No. PCB-450
 HF-1000 Tuned Input PCB
 Ray W. Connin
 November 23, 1994
 Rev. 2: 11/04/95

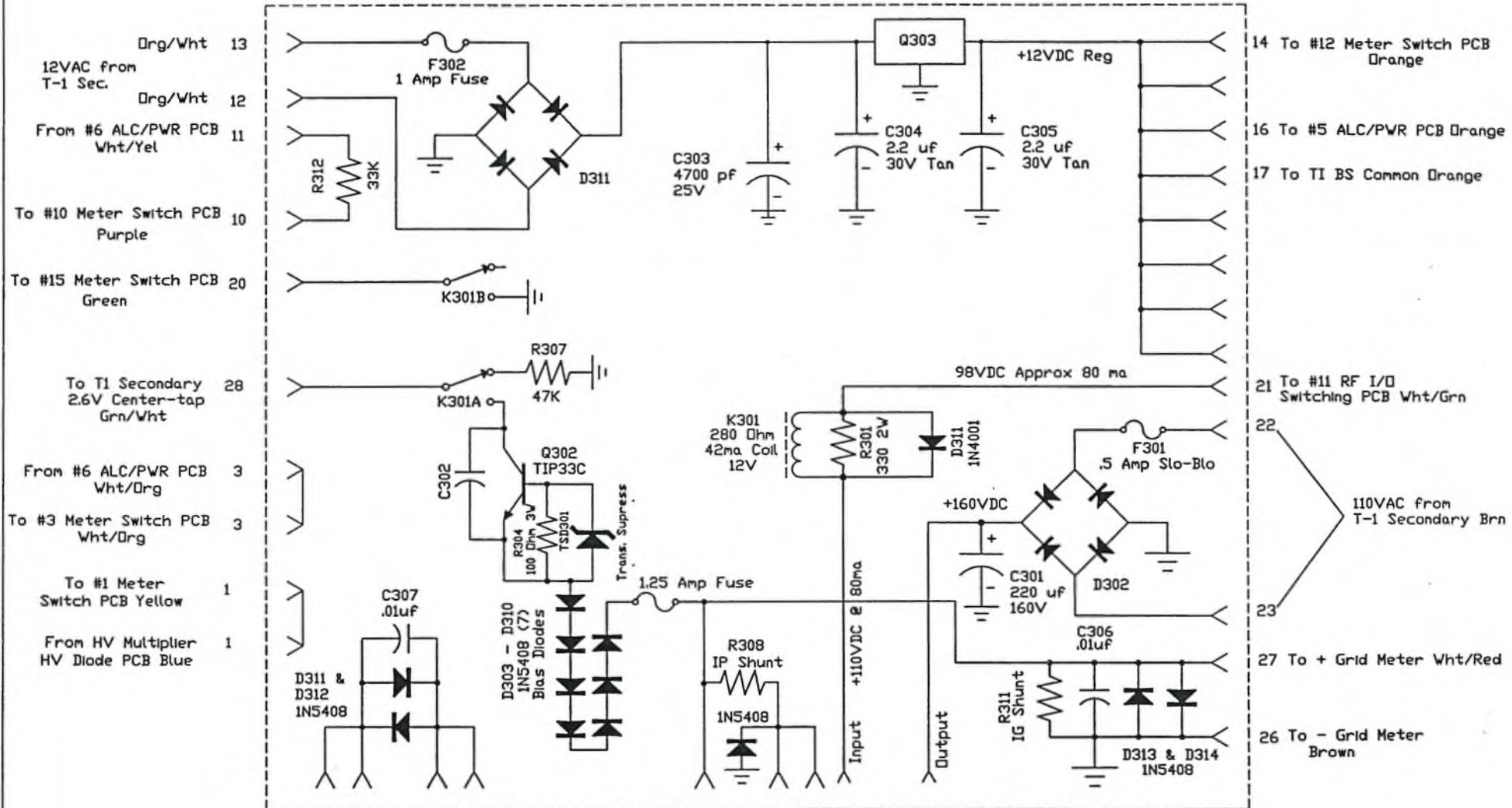

Drg/Wht 13
 12VAC from
 T-1 Sec.
 Drg/Wht 12
 From #6 ALC/PWR PCB
 Wht/Yel 11
 To #10 Meter Switch PCB
 Purple 10
 To #15 Meter Switch PCB
 Green 20
 To T1 Secondary
 2.6V Center-tap
 Grn/Wht 28
 From #6 ALC/PWR PCB
 Wht/Drg 3
 To #3 Meter Switch PCB
 Wht/Drg 3
 To #1 Meter
 Switch PCB Yellow 1
 From HV Multiplier
 HV Diode PCB Blue 1

14 To #12 Meter Switch PCB
 Orange
 16 To #5 ALC/PWR PCB Orange
 17 To T1 BS Common Orange
 21 To #11 RF I/O
 Switching PCB Wht/Grn
 22
 110VAC from
 T-1 Secondary Brn
 23
 27 To + Grid Meter Wht/Red
 26 To - Grid Meter
 Brown

To #A Meter Switch PCB A
 Red
 To + Multimeter +
 Red
 To #C Meter Switch PCB C
 Yellow
 To - Multimeter -
 Yellow
 To #2 Meter Switch PCB 2
 Wht/Blu
 To #8 Meter Switch PCB 8
 White
 From #5 B- Diode PCB 8
 White
 From R305 & R306 25
 Wht/Pur
 To R305 & R306 24
 Wht/Brn

QRD Technologies, Inc.
 LV & Bias PCB
 Part No. PCB-260
 Ray W. Connin
 December 28, 1994
 Rev. 5: 09/12/96

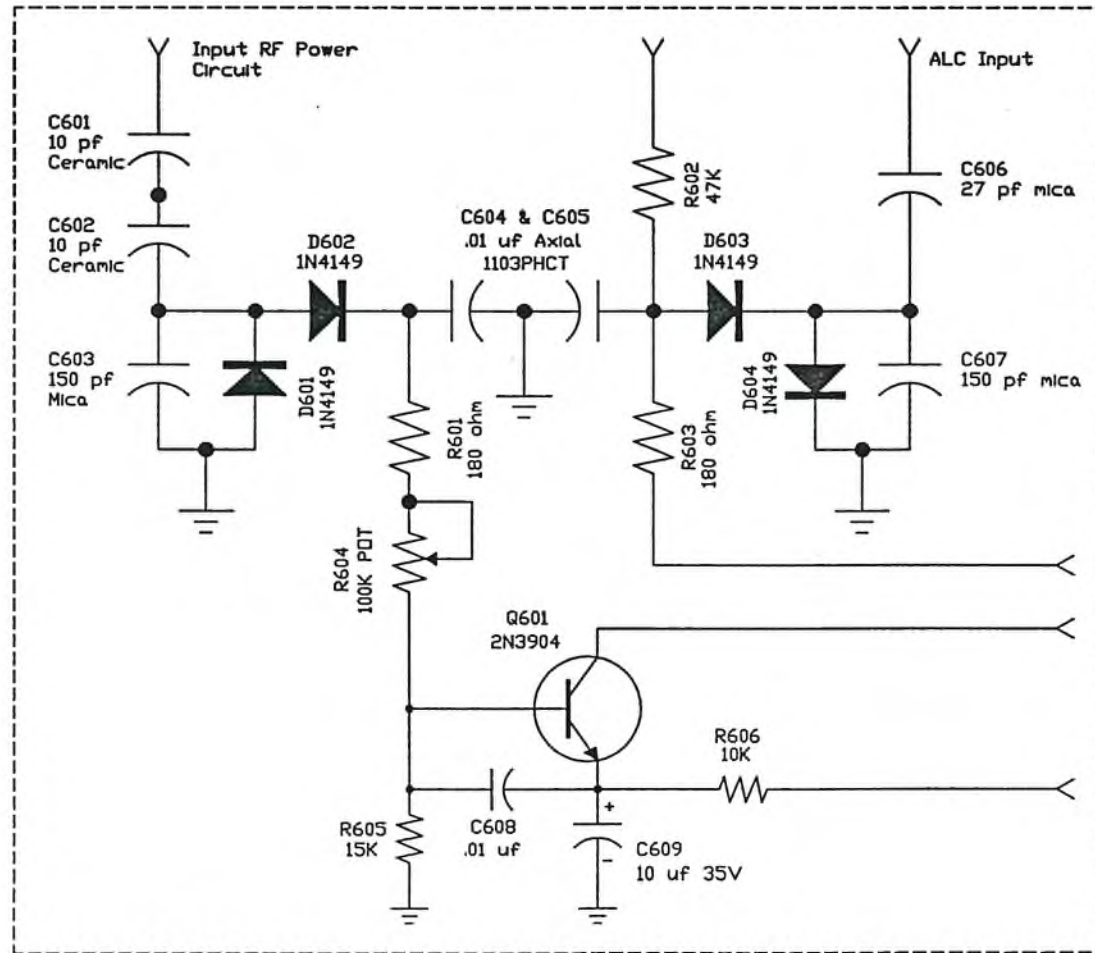

3 RF Input from 4-1
Xfmr Black

1 ALC Output to R13 PDT
Front Panel Gray

4 RF Input from #5 RF
I/O Switch PCB Wht/Blu

- 2 To #11 LV & Bias PCB Wht/Yel
- 5 From #16 LV & Bias PCB Orange
- 6 From #3 LV & Bias PCB Wht/Org

QRD Technologies, Inc.
ALC/Power PCB
Part No. PCB-610
Ray W. Connin
December 28, 1994
Rev. 03/07/95

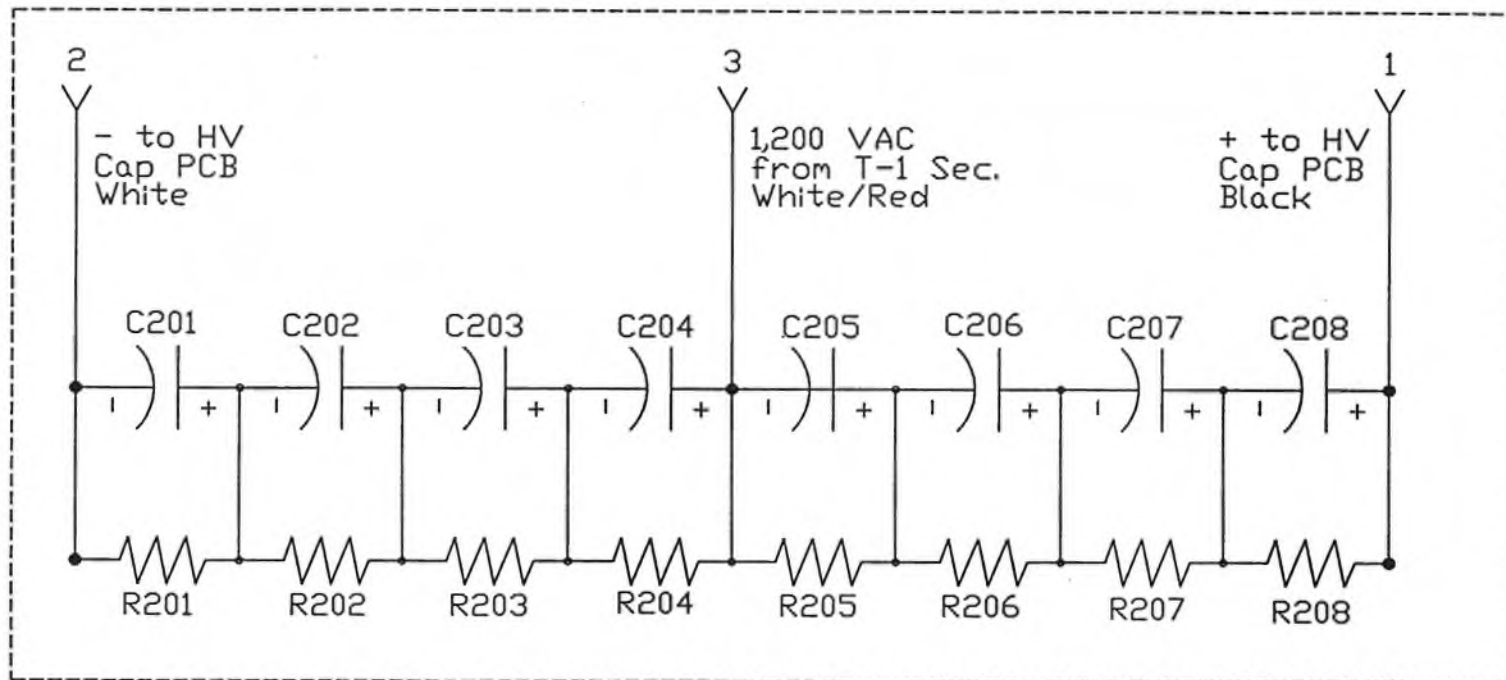

C201 - C208 270uf 450V
 R201 - R208 50K 5W

QRQ Technologies, Inc.
 H.V. Capacitor PCB
 Part No. PCB 105
 Ray W. Connin
 December 28, 1994

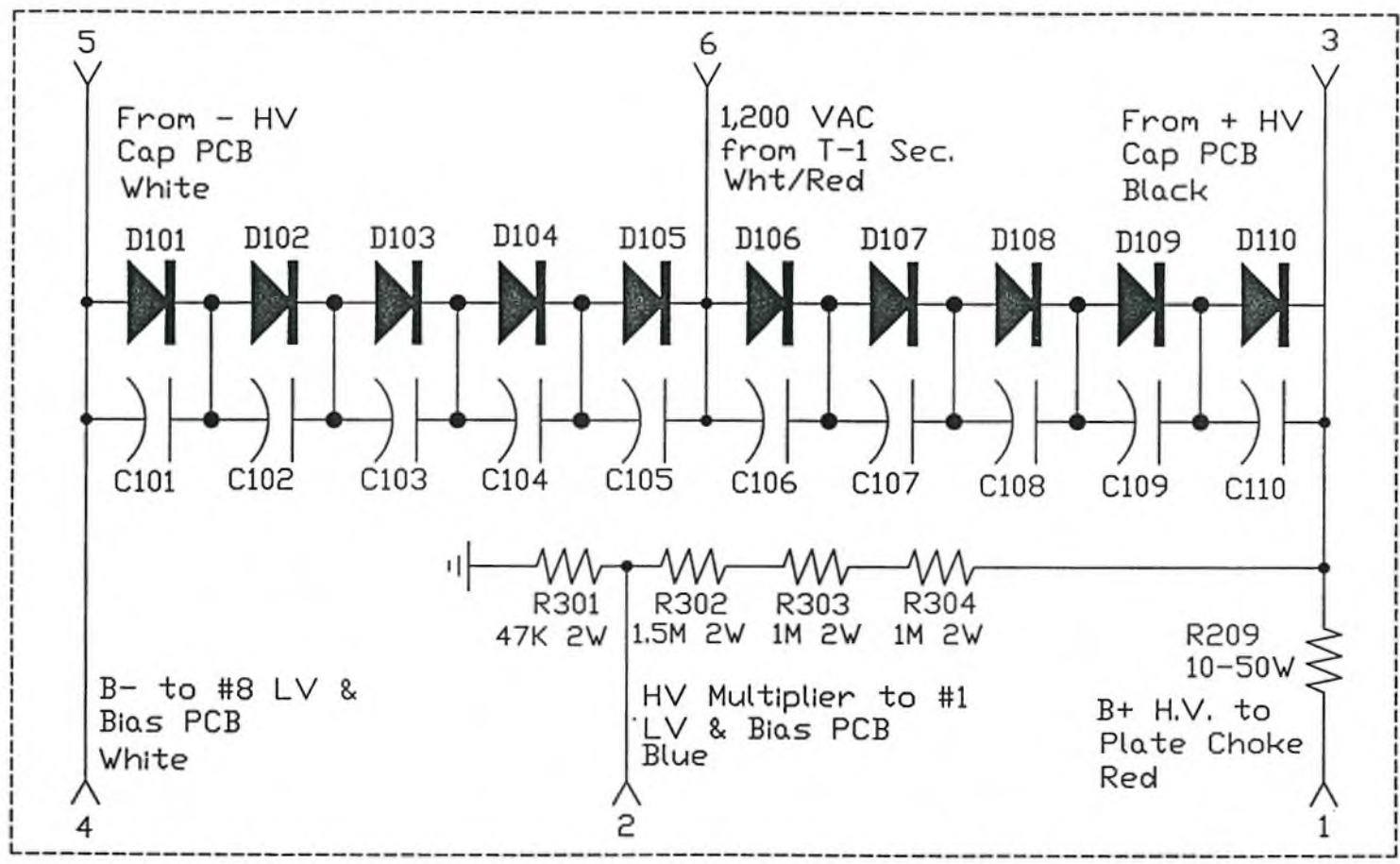

D101 - D110 1N5408
C101 - C110 .01uf 500V

QRD Technologies, Inc.
H.V. Diode PCB
Part No. PCB-110
Ray W. Connin
December 28, 1994

ADDENDUM # 3

PCB LAYOUTS

QRD Technologies, Inc.
 H.V. Capacitor PCB
 Part No. PCB-105
 Ray W. Connin
 December 28, 1994

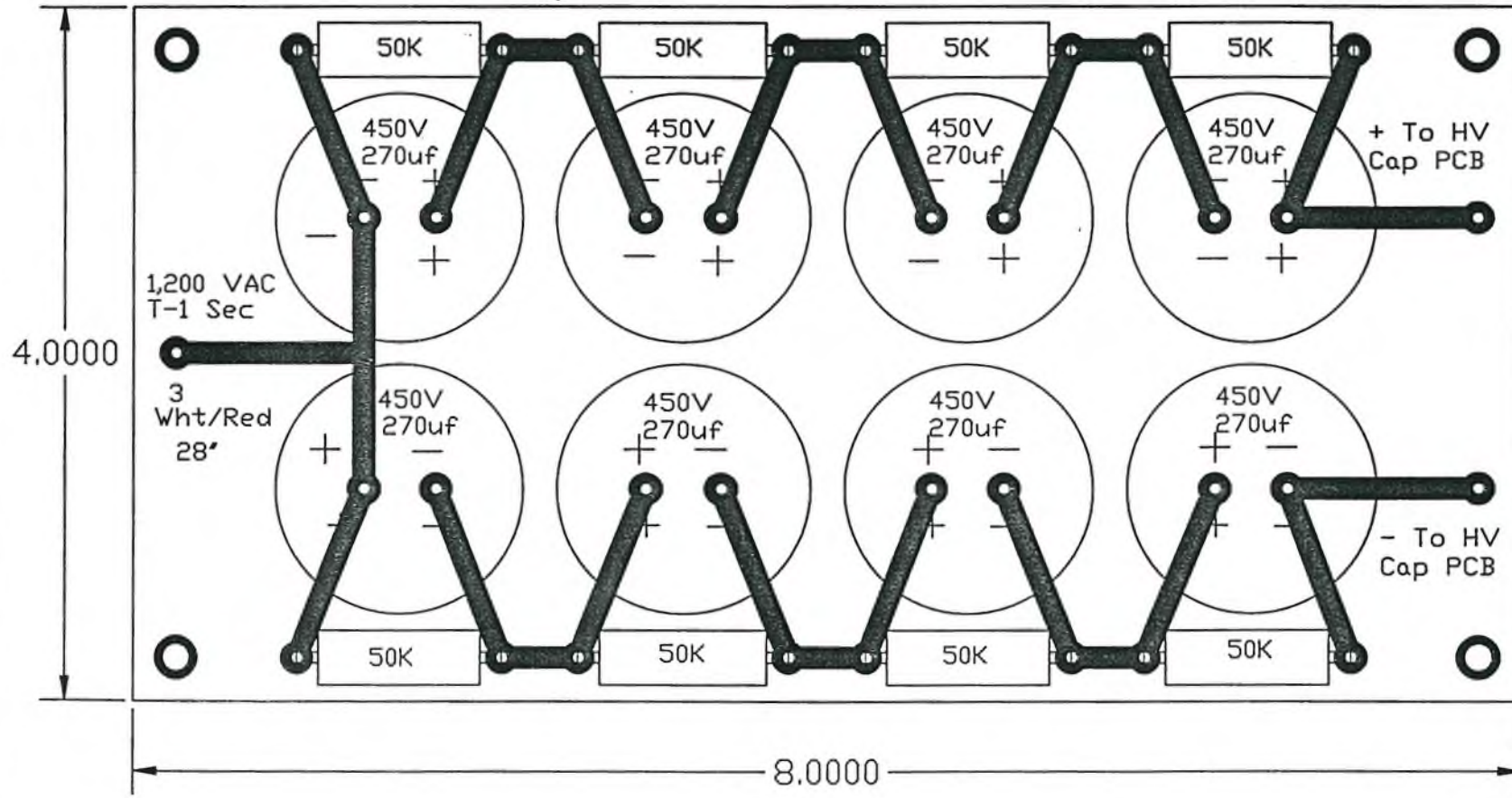

1
Black 4'

2
White 4'

Note: All small holes .0625 dia.
 All large holes .1250 dia.
 Four Corner Holes .1562 dia

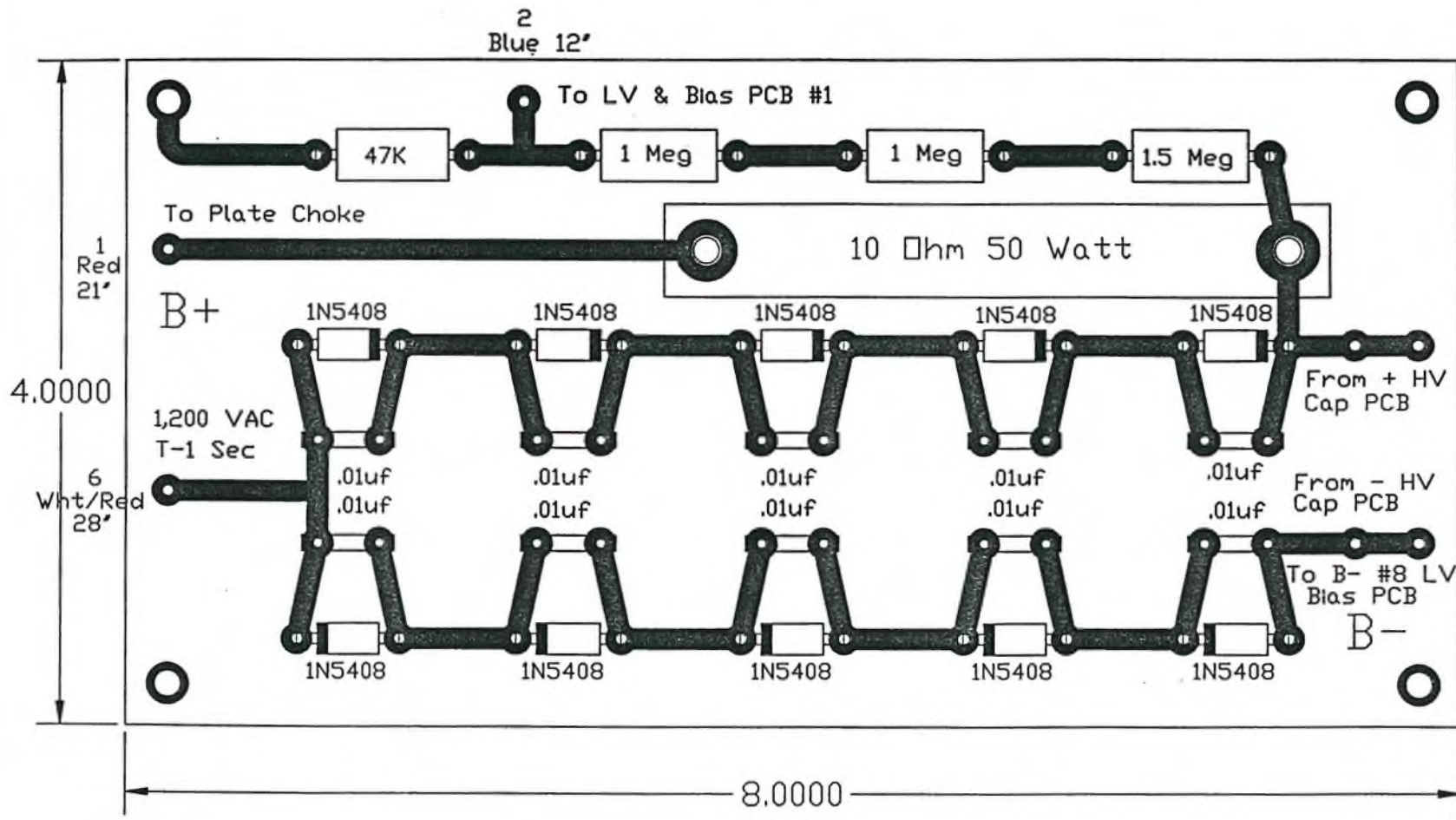

QRQ Technologies, Inc.
 H.V. Diode PCB
 Part No. PCB-110
 Ray W. Connin
 December 28, 1994

Note: All small holes .0625 dia.
 All large holes .1875 dia.
 Four Corner Holes .1562 dia

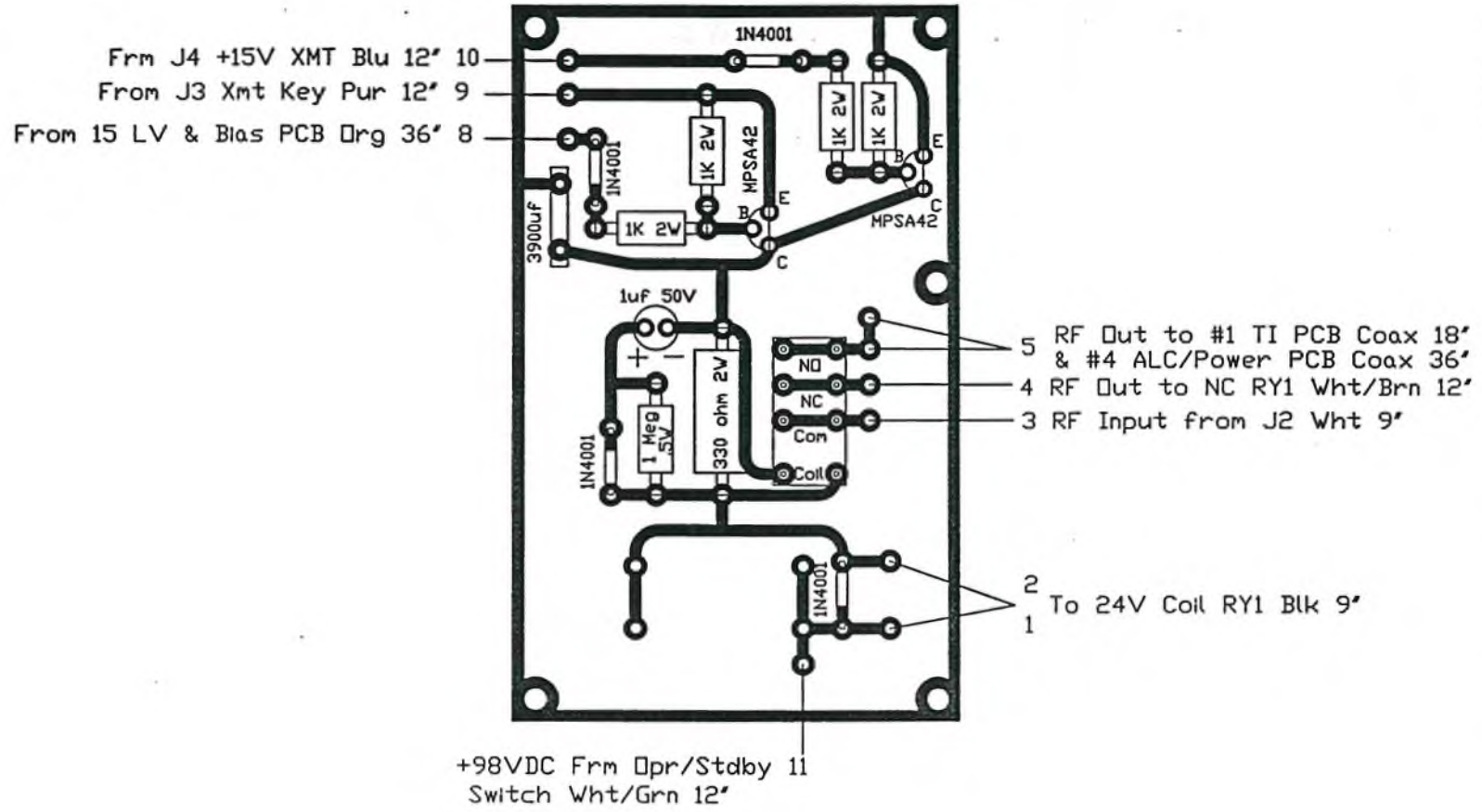

GRD Technologies, Inc.
 RF I/O Switching PCB
 Part No. PCB-350
 November 12, 1994
 Rev. 4: 03/20/98

Note: All Holes .0625 Dia.
 Four Corner Holes .1250 Dia.
 One Large Hole .1250 Dia.

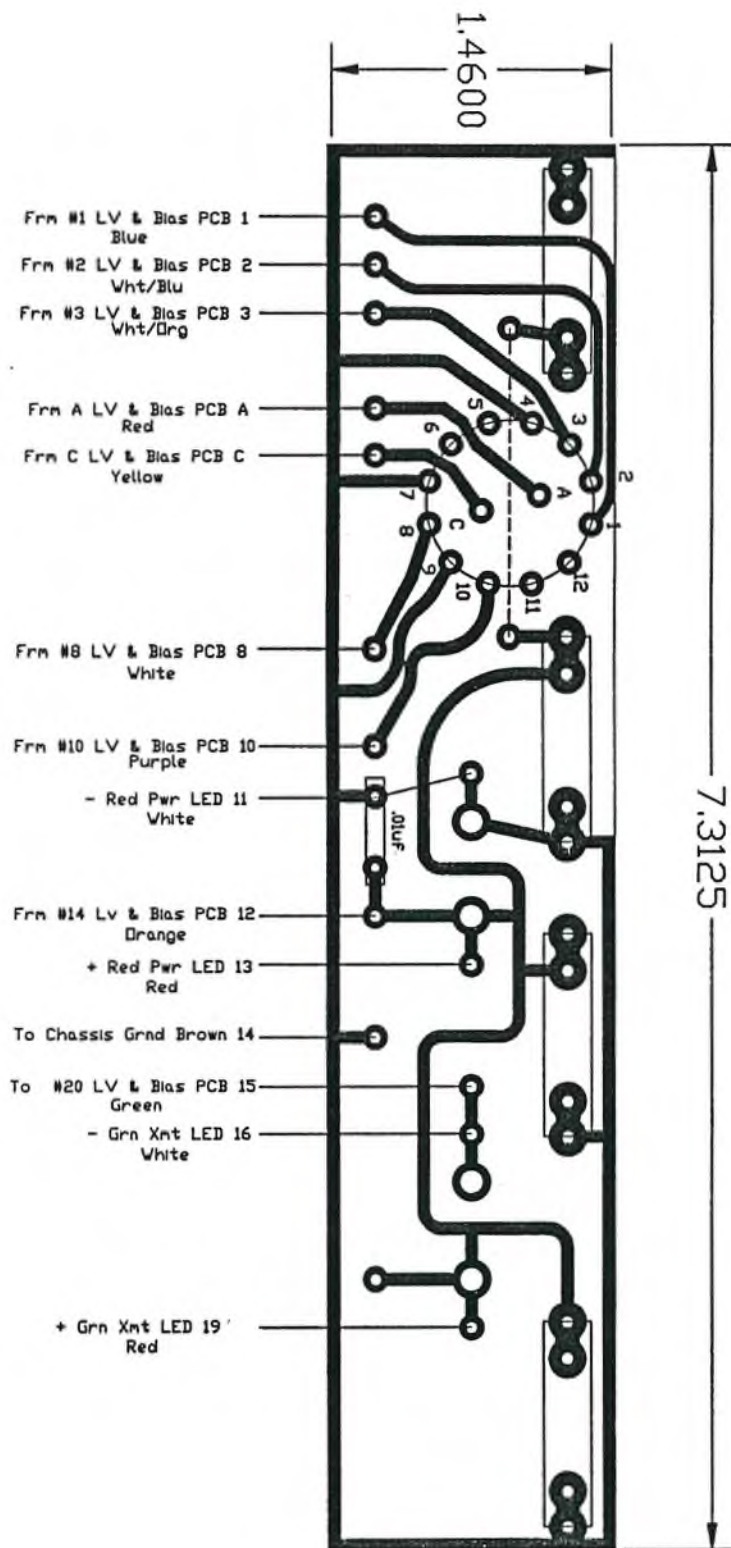

Note: All small holes .0625 dia.
All large holes .1250 dia.

QRD Technologies, Inc.
Meter Switch PCB
Part No. PCB-510
Ray W. Connin
December 28, 1994
Rev. 2: 11/12/95

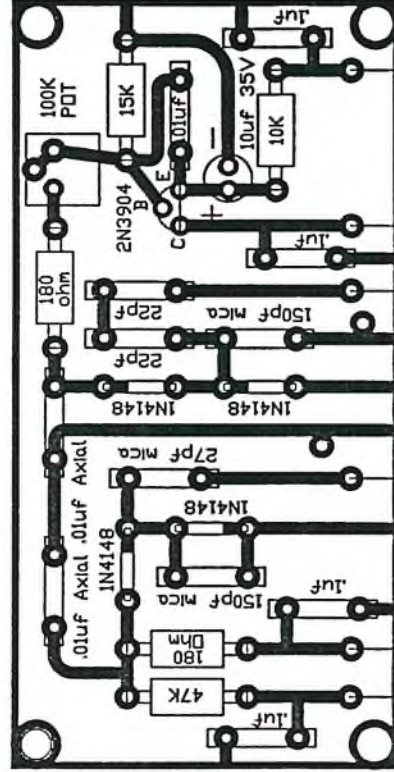

- 1 ALC Output to R13 PDI Front Panel Gray
- 2 To #11 LV & Bias PCB Wht/Yel
- 3 RF Input from 4-1 Xfmr Coax
- 4 RF Input from #5 RF I/O Switch PCB Coax
- 5 from #16 LV & Bias PCB Orange
- 6 PD to #3 LV & Bias PCB Wht/Orng

Note: All small holes .0625 dia.
Four Corner Holes .1875 dia

QRD Technologies, Inc.
ALC/Power PCB
Part No. PCB-610
Ray W. Conlin
December 28, 1994
Rev. 2: 11/12/97

RF In 1
Coax 18"

CIRCUIT TRACE
FOIL SIDE

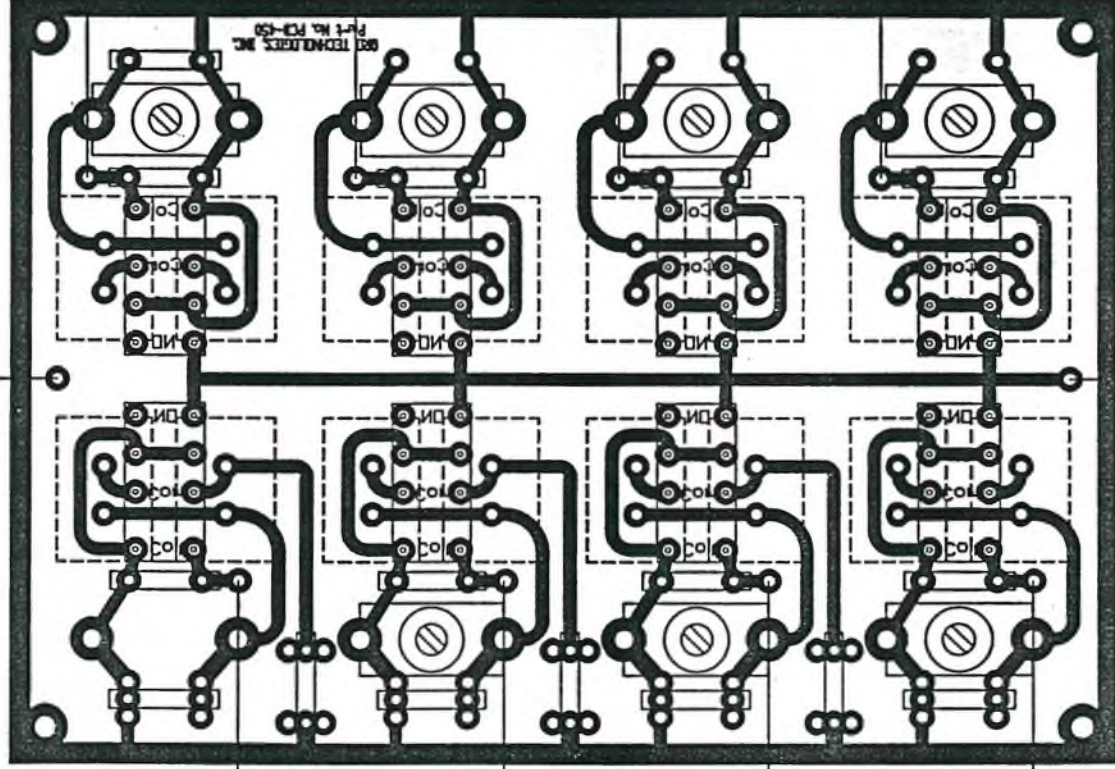

To 17M TI Bnd Swtch 8
Grn/Wht 40"

To 15M TI Bnd Swtch 9
White 40"

To 12M TI Bnd Swtch 10
Drg/Wht 40"

To 10M TI Bnd Swtch 11
Red 40"

4 To 160M TI Bnd Swtch
Blue 40"

5 To 80M TI Bnd Swtch
Wht/Brn 40"

6 To 40M TI Bnd Swtch
Yellow 40"

7 To 20M TI Bnd Swtch
Wht/Pur 40"

Note: All Small Holes .0625 Dia
All Large Holes .1250 Dia
Four Corner Holes .1875 Dia
Plate Through All Holes

QRD Technologies, Inc.
HF-1000/2000 Tuned Input PCB
Part No. PCB-450
Ray W. Connin
November 23, 1994
Rev. 5: 03/05/99

RF Out 2
GP Side
Coax 24"

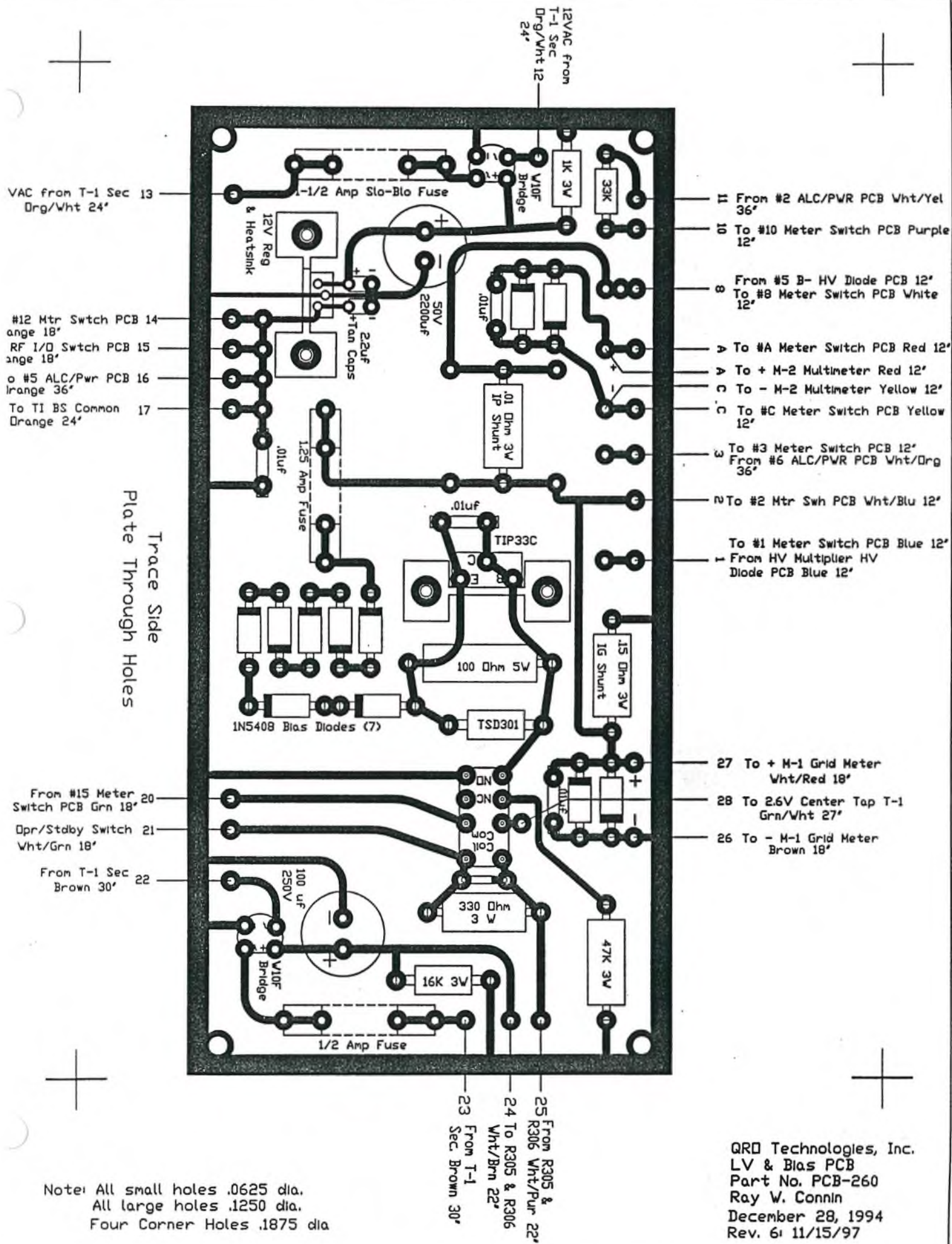

Circuit Trace Side

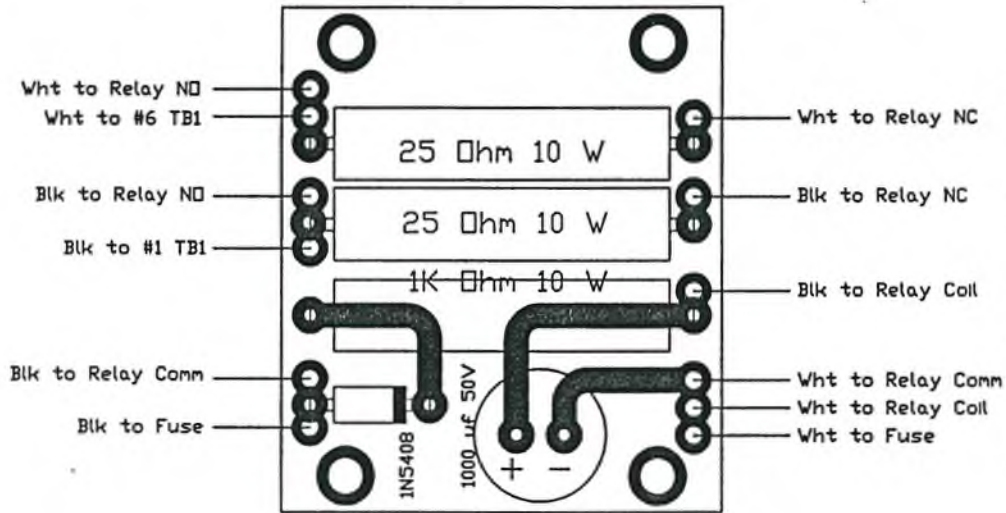

Plate Through All Holes

such in HF 1000
PC-Board + Relais k-1
an Rückwand!

QRD Technologies, Inc.
Step Start PCB HF-2000
Part No.: 06126
Ray W. Connin
October 12, 1998

ADDENDUM # 4

**FRONT & REAR PANEL
PICTORIALS**

QRO HF-1000/2000
FRONT PANEL PICTORIAL

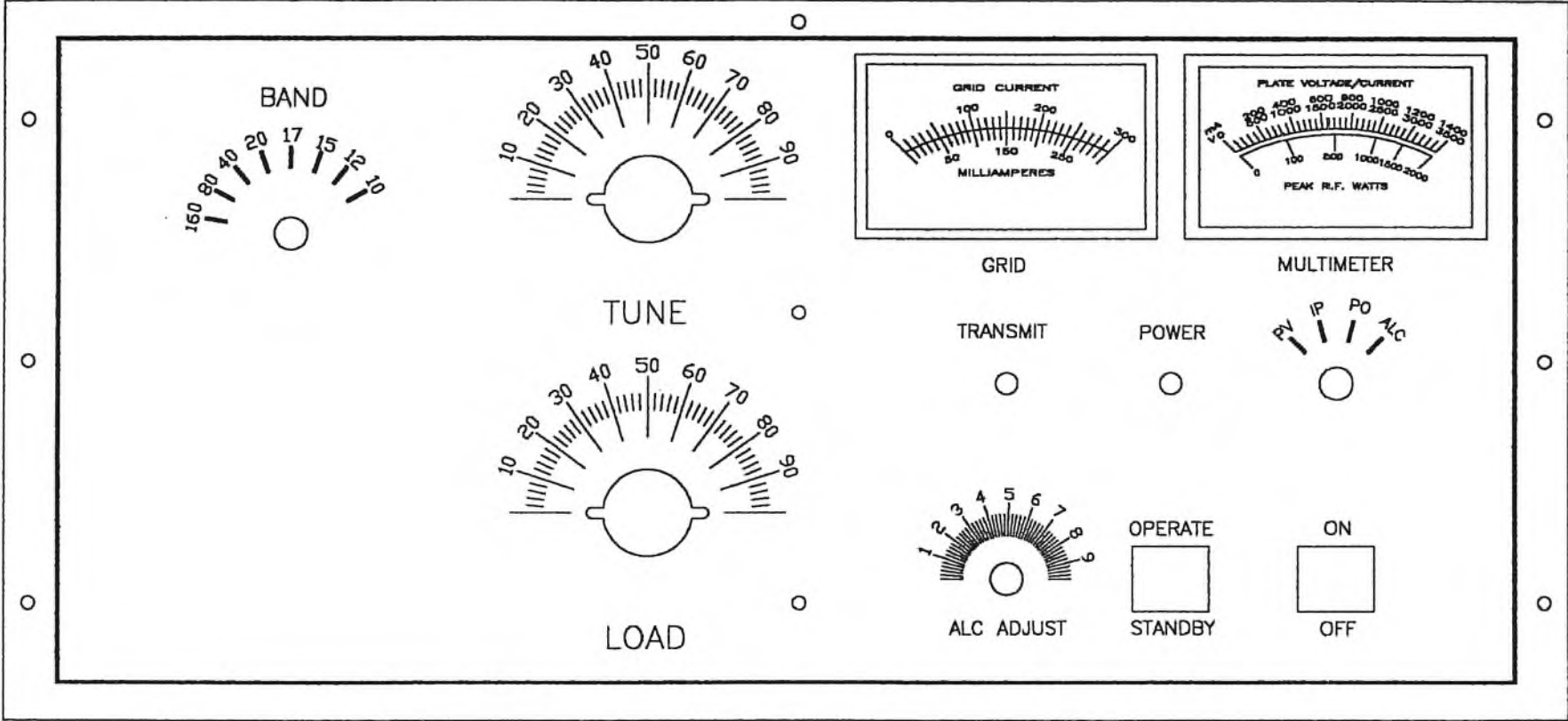

QRD HF-1000/2000
REAR PANEL PICTORIAL

