QRO HF-2500DX MARK III LINEAR AMPLIFIER

INSTRUCTION MANUAL



WARNING: THIS UNIT IS SOLD FOR EXPORT OR TO BE MODIFIED AS AN INDUSTRIAL, SCIENTIFIC, OR MEDICAL DEVICE BY THE PURCHASER AS SPECIFIED IN CFR 47, PART 18, SUBPART 18.121. OPERATION OF THIS LINEAR AMPLIFIER IN THE USA AS AN AMATEUR RADIO LINEAR AMPLIFIER IS UNLAWFUL AND NOT PERMITTED.

QRO TECHNOLOGIES, INC

1117 West High Street
P.O. Box 939
Bryan, OH 43506 USA
Tel & Fax: (419) 6362721
E-mail: sales@qrotec.com
Internet: <http://www.qrotec.com>

PUBLICATION DATE: December 1998
COPYRIGHT 1998 BY QRO TECHNOLOGIES, INC. ALL RIGHTS RESERVED.
THIS MANUAL OR ANY PART THERE OF MAY NOT BE REPRODUCED IN ANY FORM
WITHOUT PERMISSION FROM QRO TECHNOLOGIES, INC.

SPECIFICATIONS

| | |
|---|---|
| Band Coverage: | 160, 80, 40, 20, 17, and 15 (12 & 10 export only) meter amateur bands. 12 & 10 meter also useable in USA with proof of license and user modification. |
| Drive Power Required: | 50 to 60 watts nominal for rated output |
| Maximum Output Power: | 3,500 watts SSB, 2000 watts CW, and 2,000 watts continuous carrier or modulated carrier with 15 minute time limit. Carrier operation (RTTY, FM, or SSTV) for more than 15 minutes requires use of auxiliary cooling, |
| Power Gain: | Nominally 14 db |
| Automatic Limiting Control (ALC): | 0 to -20 Volts negative going, adjustable from Front Panel |
| Harmonic Suppression: | 2nd Harmonic -40 db, 3rd - 10th at least -48 db |
| Keying: | Requires relay contact closure or sink of 80 ma @ 100 VDC or +15 VDC on transmit supplied by transceiver |
| Input Impedance: | 50 ohms unbalanced, VSWR <1.5:1 |
| Output Impedance: | 50 ohms unbalanced with SWR 2:1 or less |
| Tube Requirement (3): | Svetlana GU74b (4CX800A) (3) Tetrodes |
| Power Line Requirement: | 200/240 VAC, 50/60 Hz at 30 amperes maximum |
| Front Panel: (See Front Panel Pictorial) | Multimeter (Plate Voltage, Plate Current, Screen Voltage) Screen Grid Current Meter Multimeter Function Switch Transmit LED Indicator Power LED Indicator Power On/Off Switch Tune & Load Controls with 6-1 Reduction Drives Bandswitch Fan High/Fan Low Switch |
| Rear Panel: (See Rear Panel Pictorial) | RF Input (SO-239) RF Output (SO-239) Transmit Keying Line (RCA Phono Socket) or +15 V Supplied by Transceiver on Transmit (RCA Phono Socket) ALC Output (RCA Phono Socket) Ground Post Fuses (two 30 ampere for 100/120 VAC) |
| Dimensions: | 20"W X 19"D X 8"H |
| Net Weight: | 95 lbs. (51 kgs.) |

TABLE OF CONTENTS

| | |
|---|----------------------------------|
| Warranty | 4 |
| Proprietary Notice | 4 |
| Safety Notification | 5 |
| Unpacking & Inspection | 6 |
| Reshipment Instructions | 6 |
| Top Cover Removal | 6 |
| Transformer & Tube Installation | 6, 7 |
| Line Voltage Selection Power Block Wiring | 7 |
| Introduction | 7, 8 |
| Location | 8 |
| AC Power Line Considerations | 8, 9 |
| Antenna | 9 |
| Grounding | 9 |
| Equipment Interconnections | 9, 10 |
| Safety Interlock Switch | 10 |
| Driving Power | 10 |
| Tube Precaution | 10 |
| Reading the Meters | 10, 11 |
| Front Panel Switches & Controls | 11, 12 |
| Initial Power Up | 12 |
| Tune-Up Procedure | 12, 13, 14 |
| Using the ALC Adjust Control | 14 |
| Periodic Maintenance | 14, 15 |
| Troubleshooting Chart | 15, 16, 17 |
| Circuit Descriptions | 17, 18, 19 20, 21, 22 |
| Addendum #1 | Power Block Wiring |
| Addendum #2 | Schematics |
| Addendum #3 | PCB Layouts |
| Addendum #4 | Front & Rear Panel Pictorials |

WARRANTY

The HF-2500DX Mark III is warranted against defects in material and workmanship for a period of two years for the original date of sale. This warranty does not cover the 4CX800A (GU-74b) tetrodes which carry a separate warranty for a period of one year from the date of original sale. During the warranty period, QRO Technologies, Inc. will repair the amplifier or tube if it is defective in any way in material and workmanship. The warranty does not cover any defects resulting from improper use by the buyer or inadequate maintenance. In such cases the repair will be billed at prevailing service rates.

For warranty service or repair, the amplifier must be returned to the factory for authorized service. The buyer shall prepay shipping and insurance charges, QRO Technologies, Inc. will pay shipping and insurance charges to return the amplifier to the buyer. For export customers, QRO Technologies, Inc. will pay the shipping charges from the factory to the nearest export port at prevailing UPS Ground Service rates. Please call or fax the factory at 1-800-956-2721 / (419) 636-2721 for shipping instructions. Make sure when returning the amplifier you have insured the instrument for the full replacement cost. QRO Technologies, Inc. is not liable for any damage incurred during return shipments.

PROPRIETARY NOTICE

This instruction manual, schematic diagrams, printed circuit board layouts, and technical data herein disclosed, are proprietary to QRO Technologies, Inc. and shall not, without express written permission of QRO Technologies, Inc., be used, in whole or part to solicit quotations from a competitive source or used for manufacturing by anyone other than QRO Technologies, Inc. The information herein has been developed at private expense, and may only be used for operation and maintenance reference purposes or for purposes of engineering evaluation and incorporation into technical specifications and other documents which specify procurement of products from QRO Technologies, Inc. This amplifier is covered by copyrights both in the United States of America and throughout the world.

ALWAYS THINK SAFETY

THIS LINEAR AMPLIFIER DESCRIBED IN THIS MANUAL CONTAINS VOLTAGE HAZARDOUS TO HUMAN LIFE AND SAFETY WHICH IS CAPABLE OF INFLICTING PERSONAL INJURY. NEVER OPERATE THE AMPLIFIER WITH THE TOP COVER REMOVED AND THE TOP COVER SAFETY SWITCH DEFEATED. BEFORE REMOVING THE TOP COVER MAKE SURE THE AC LINE POWER CORD HAS BEEN DISCONNECTED FROM THE AC POWER SOURCE. ALLOW A MINIMUM OF 5 MINUTES TO ELAPSE BEFORE REMOVING THE TOP COVER AFTER POWER HAS BEEN REMOVED. THIS IS NECESSARY TO ALLOW THE PLATE VOLTAGE FILTER CAPACITORS TO BLEED DOWN TO A SAFE LEVEL.

If this amplifier is to be powered from the AC line (mains) through an autotransformer (such as a Variac or equivalent) ensure that the common connector is connected to the neutral (earth pole) of the power supply.

Before operating this unit ensure that the protection conductor (green wire) is connected to the ground (earth) protective conductor of the power outlet. Do not defeat the protective features of the third protective conductor in the power cord by using a two conductor extension cord or a three-prong/two-prong adapter.

Before operating this unit:

1. Ensure that the instrument is configured to operate on the voltage available at the power source. (See Installation Section)
2. Ensure that the proper fuses are in place in the amplifier's AC line fuse holders located on the rear panel.
3. Ensure that all other devices connected to or in proximity to this amplifier are properly grounded or connected to the protective third-wire earth ground.

If at any time the amplifier shows visible damage, has sustained stress, emits a foul smell, fails to operate satisfactorily, it should not be used until its performance has been checked by qualified service personnel.

UNPACKING AND INSPECTION

The amplifier is shipped in three cartons: amplifier, plate transformer, tubes/control transformer. Before unpacking each carton, check the exterior of the shipping carton for any sign of damage. All irregularities should be noted. Unpack and remove each component carefully from its carton, preserving the factory packaging as much as possible. Inspect each component for any noticeable defect or damage. Notify QRO Technologies if any defect or damage is apparent.

RESHIPMENT INSTRUCTIONS

Use the original packaging if it is necessary to return the amplifier, transformer, or tube to QRO for servicing. The original shipping carton and the interior corner pads are designed to provide the necessary support for safe shipment or reshipment. If the original carton along with the internal packaging is not available, contact the factory and a new carton will be shipped to you at a nominal cost. Always insure the package for the full replacement value and ship via UPS ground service. **QRO Technologies, Inc. will not be responsible for any damage or loss during return shipment.**

TOP COVER REMOVAL

Remove the Amplifier's top cover by removing the ten 6-32 x 3/8 Phillips Head machine screws and their associated flat washers. The sides of the top cover may bend outward when the screws are removed. This is normal, and they will return when you replace the screws and washers.

TRANSFORMER AND TUBE INSTALLATION

Before performing any of the following installation procedures, make sure that the amplifier has not been plugged into the AC supply line.

The Amplifier is shipped with the tubes, plate transformer, and filament transformer each shipped in a separate cartons. As part of the installation process, you must install the tubes and transformers.

Filament & Control Transformer: Remove the filament & control transformer (smallest transformer) from its shipping carton. You will notice one indexed connector on the ends of the transformer leads. Place this transformer in the rear of the power supply compartment next to the blower. Position the transformer so the transformer leads and indexed connector is on the right side when viewed from the front of the amplifier. The four mounting holes on the chassis should align with the transformer mounting feet. Use at least three of the four 1/4-20 x 5/8 screws and nuts to secure the transformer. One mounting foot is difficult to reach, and it is not absolutely necessary to secure it. Locate the amplifier's matching index connector. Connect the two matching connectors. There is only one way the two connectors can go together. When the two connectors are locked together, you should hear a snap sound.

PLATE TRANSFORMER: Remove the plate transformer (large transformer) from its shipping carton. You will notice two indexed connectors. Position the transformer so the connector with the red leads is on the left and the connector with the black and white leads is on the right side when

viewed from the front of the amplifier. Carefully place the plate transformer into the power supply compartment cavity between the blower and the circuit board stack located behind the front panel meters. Align the transformer with the chassis mounting holes and secure it to the chassis with at least three 1/4-20 x 5/8 mounting screws and nuts. The fourth hole is rather difficult to access, and it is not absolutely necessary to secure it. Locate the two amplifier's matching index connectors. Connect the two matching connectors. There is only one way the two connectors can go together. When the two connectors are locked together, you should hear a snap sound.

TUBES: The tube sockets are located on the left side of the amplifier. They each have seven contacts which match the seven pins on the 4CX800A tetrodes. Remove the tubes from their shipping cartons, and insert each tube into the socket making sure that the pins align with the socket contacts. The tubes should seat without too much pressure applied. If you have to use a lot of pressure, you most likely have the wrong pin alignment. If the tube pins and socket contacts are not aligned, the amplifier will not function properly and damage to the tube may result. Once the tubes have been properly seated in their sockets, slip the two anode connectors over the tube anodes.

LINE VOLTAGE SELECTION POWER BLOCK WIRING

Your amplifier has been factory wired for 220 - 240 VAC 50/60 Hz. operation. If you need to change the line voltage configuration, refer to the two Power Block Wiring Diagrams while reading this section. Locate the Line Voltage Power Block. It is located inside the amplifier just behind the filament & control transformer. It contains 5 screw connection terminals. It also has black and white leads connected to it.

Convert 240 VAC to 200 VAC: One wire jumper (J1) is connected to terminals 3 & 4. Remove the J1 connection to terminal 3 and connect it to terminal 2. Remove the small back wire connected to the right side of terminal 3, and connect it to right side of terminal 2. Remove the large white wire connected to the left side of terminal 6 and connect it to the left side of terminal 5. Make sure all screws are tightened.

You are now ready to replace the amplifier's top cover. **The hot air exhaust holes should be located on the top left and the cooling air entry holes should be on the right side.** Align the mounting holes with the corresponding threaded inserts located on the chassis. You may also need to use an alignment tool such as an awl. You may need to lightly tap the top cover into place with your hand. The left and right sides of the top cover may need to be pushed inward as you place the mounting screws into place. Replace the ten 6-32 x 3/8 mounting screws and washers. Partially tighten each screw. When all ten screws have been inserted, tighten all the screws. **Double check to make sure that the cooling air entry holes are on the right side, and the hot exhaust air exit holes are located on the top left directly over the tubes.**

INTRODUCTION

The QRO Model HF-2500DX Mark III Linear Amplifier is a completely self-contained, grounded cathode grid driven, linear amplifier. It is designed to operate at 3,500 watts SSB, 2,500 watts cw, and 2,000 watts continuous or modulated carrier (e.g., RTTY, FM, SSTV). **Continuous or modulated carrier operation for more than 15 minutes at or near maximum rated output power requires use of auxiliary cooling.** The HF-2500DX Mark III is designed to be used with

any transceiver which can deliver adjustable output power from 0 to 100 watts. A grid driven input circuit using a 50 ohm 100 watt non-inductive shunt resistor feeds each 4CX800A tetrode tube which are connected in a grounded cathode configuration. An ALC circuit develops negative voltage that can be fed back to the transceiver to reduce its gain when the amplifier is overdriven. The antenna transmit-receive (T/R) relay is normally actuated by relay contacts, or an electronic switch, in the transceiver to place the amplifier in the transmit mode. The relay contacts must be connected to ground. Operation problems will occur if the contacts have more than zero volts DC. A +15 VDC contact is provided for transceivers utilizing a + 15 VDC on transmit for T/R switching.

LOCATION

Do not operate the Amplifier in excessively warm locations or near heating vents or radiators. Be sure air can circulate freely around and through the Amplifier cabinet, and can provide an unobstructed air inlet for the internal cooling fan. Do not place any books, magazines, manuals, or equipment that will impede the free flow of air near the sides and the hot air exhaust holes located on the top of the cabinet. The internal fan allows an air flow of approximately 50 CFM. Do not use an external auxiliary cooling fan with less than 50 CFM capacity. The exhaust air becomes quite warm at high power levels. Do not position any heat-sensitive objects in the exhaust airflow path.

AC LINE POWER CONSIDERATIONS

Before operating the amplifier, verify that the AC Voltage Power Block located inside the amplifier has been wired correctly for the local AC supply you will be using. See the Voltage Power Block Wiring Diagram for the correct wiring. **Make sure the AC line cord has been disconnected and filter capacitors have no charge on them before removing the top cover.**

Verify that the rating of the line fuses located in the rear panel fuse holders is suitable for the AC line voltage you will be using. The fuse should be the ceramic cartridge slo-blow type. The rating should be 30 Amperes.

Use only AC power outlets having a protective ground for connection to the amplifier. **DO NOT USE** 2 conductor extension cords or 3 prong to 2 prong adapters that do not provide a protective ground connection. Connection of the power cord to the power outlet must be made in accordance with the following standard color code:

| | <u>American</u> | <u>European</u> |
|----------------|-----------------|-----------------|
| Live | Black | Brown |
| Neutral | White | Blue |
| Ground (Earth) | Green | Green/Yellow |

Use the following NEMA plug configuration: 200/240 VAC 20 Ampere 6-15P or 6-20P

Due to the power involved, this Amplifier should have its own 240 VAC electric service line. This line should have three 12-gauge conductors, and 20 ampere fuses in each "hot" wire. If a single 240 VAC line serves the entire station, make an effort to connect your equipment so the load is balanced between the two "hot" wires. **DO NOT** use this Amplifier at its full ratings on a regular

house wiring circuit, as the ratings of the wire will almost certainly be exceeded. Avoid excessively long runs of wire between your service entrance and the Amplifier. A heavy flow of current in such a line results in a voltage drop which can affect the performance of your equipment. No plug is supplied with the line cord. Use a plug that matches your 240 VAC receptacle (NEMA 6-15P or 6-20P). Your power connection must conform to section 210-21 (b) of the National Electric Code, which reads, in part:

"Receptacles connected to circuits having different voltage, frequencies, or types of current (AC or DC) on the same premises shall be of such circuits are not interchangeable."

When you install a new plug, make sure it is connected according to your local electrical code. Keep in mind that the green line cord wire is connected to the Amplifier chassis.

ANTENNA

The output circuit of the Amplifier is designed to be connected to an unbalanced transmission line that has a 50 ohm characteristic impedance. Lines of other characteristic impedance may be used providing the SWR (standing-wave-ratio) does not exceed 2:1.

The RF OUT connector is a UHF type SO-239. You will need a mating PL-259 plug for your transmission line.

Use coaxial cables like RG-8U, RF-11U, or similar types, for the transmission line. Due to the power level, the smaller types RG-58U and RG59/U are not recommended.

The "A.R.R.L. Antenna Book" is readily available and includes comprehensive reference work on transmission lines and antennas. Other similar handbooks for the radio amateur are offered for sale and can often be found in a public library.

GROUNDING

Connect a good earth or water pipe ground to the ground post on the rear of the Amplifier. Use the heaviest and shortest connection possible. Before you use a water pipe ground, inspect the connections around your water meter and make sure that no plastic or rubber hose connections are used. These connections interrupt the continuity to the water supply line. Install a jumper around any insulating water connectors you may find. Use heavy copper wire and pipe clamps. It is best to ground all equipment to one point at the operating position and then ground this point as described above.

EQUIPMENT INTERCONNECTIONS

Interconnection between the Amplifier and a typical transceiver is shown in the "Interconnection Diagram" located inside your transceiver owners manual. Many brands of equipment usually follow the same general pattern. Please refer to this diagram plus the amplifier's Rear Panel Pictorial while reading the following:

RF IN Connect this socket to the RF output connector of your transceiver.

RF OUT Connect this socket to the cable coming from your antenna.

Note: *Use shielded cable, such as audio-type cable, for the following connections.*

KEY XMT Connect this socket to the T/R relay socket on your transceiver. This connector requires contacts that are normally open in the receive mode and closed in the transmit mode. **This contact sinks 12 VDC to ground at 80 mA.**

+15 V XMT If your transceiver has a provision for +15 VDC on transmit for keying external devices, such as linear amplifiers, connect this socket to the appropriate socket on your transceiver.

Note: If your transceiver has neither of the above keying methods, you will have to use some other means. For instance, you could use a shorted RCA phono plug by placing it in the Key XMT socket. Then, you would have to manually turn off and on the Operate/Standby switch located on the front panel.

ALC OUTPUT Connect this socket to the ALC input of your transceiver. A 0 to 20 V negative ALC voltage is present at this socket. Refer to your transceiver manual for proper connection information. Whenever the Amplifier is overdriven, the ALC circuitry creates a negative voltage that is fed back to the transceiver to reduce its gain and help prevent "flat-topping". Protective circuitry of this nature is a valuable circuit element, but it is not a substitute for proper adjustment of the transceiver drive.

SAFETY INTERLOCK SWITCH

While the Amplifier's top cover is in place, the interlock switch closes to allow AC line voltage to reach the power transformer. When the top cover is removed, the interlock switch opens and disconnects the line voltage. This does not discharge the bank of power supply filter capacitors. Be sure to allow the filter capacitors to discharge before you touch anything inside the Amplifier. You can select the High Voltage function of the Multimeter to check the high voltage potential.

DRIVING POWER

This Amplifier is designed to operate at full ratings when it is driven by a transceiver that has approximately 50 watts of RF output. If you use a transceiver that delivers more than 50 watts, carefully adjust the driving power to avoid "overdrive" and the creation of spurious signals, which create needless interference to other operators.

IMPORTANT: In no case should you advance the power output control of your transceiver beyond the point where the Amplifier's power output ceases to increase. If you turn the control past this point, nonlinear operation may occur. **You may also damage the tubes.**

TUBE PRECAUTION

After prolonged operation, let the Amplifier run for several minutes without drive applied so the

fan will cool the tubes before you turn the Amplifier off.

READING THE METERS

Refer to Front Panel Pictorial while you read the following information:

Multimeter: The Multimeter switch on the front panel of the amplifier directly below the two panel meters selects the right-hand meter functions. Read the meter scale which corresponds to the setting of the Multimeter switch as shown in Table A.

Table A

| Multimeter Switch Position | Measures | Scale Indication |
|----------------------------|----------------|---|
| Plate Voltage (PV) | Plate Voltage | Bottom scale indicates 0 to 3.5 KV (normal operating range is 3.0 KV to 3.3 KV volts) Each division represents .1 KV (100 volts). |
| Screen Voltage (SV) | Screen Voltage | Bottom scale indicates 0 to 3.5 KV (normal operating range is .35KV (350 volts) Each division represents .1 KV (100 volts). |
| Plate Current (IP) | Plate Current | Top meter scale indicates 0 to 2.8 amperes. Each division represents .8 amperes (800 milliamperes). |

Screen Grid Meter: The left-hand meter always indicates screen grid current between 0 and 150 milliamperes. Each Division indicates 5 milliamperes.

FRONT PANEL SWITCHES & CONTROLS

On/Off Switch: Rocker type switch which turn the amplifier on or off

Operate/Standby Switch: Rocker type switch used to place the amplifier in a transmit mode

Fan High/Low Switch: Rocker type switch which control blower speed

ALC Control: Varies the negative feedback voltage to your transceiver. A clockwise rotation increases this voltage which reduces the drive power delivered to the amplifier from the transceiver. The ALC line between the transceiver and the amplifier must be properly connected for this feature to operate.

Fault Light/Switch: If you amplifier is operated in such a manner to produce excessive screen grid current, a protection circuit will place the amplifier in a standby mode. A red light will light in the fault switch. The amplifier can be reset into a transmit mode by pushing the red switch. A successful reset will be indicated when the fault light turns off.

Tune Control: A 6-1 vernier drive control used to adjust the input capacitor of the pi output tank circuit during tune up. 0 - 100 logging scales provide a means to record your tune up settings for future reference.

Load Control: A 6-1 vernier drive control used to adjust the output capacitor of the pi output tank circuit during tune up. 0 - 100 logging scales provide a means to record your tune up settings for future reference.

Band Selector Switch: Selects the desired band of operation

Red LED: When lit, the amplifier has been turned on, and it has gone through its warm up cycle.

Green LED: When lit, the amplifier has been keyed and amplifying the power supplied by the transceiver.

INITIAL POWER UP

Preset the amplifier's front panel controls as follows:

| | |
|------------------------|------------------------|
| On/Off | Off |
| Operate/Standby | Standby |
| Multimeter | PV (Plate Voltage) |
| Fan | Fan High |
| ALC Adjust | Full counter clockwise |
| Tune Control | 50 |
| Load Control | 0 |
| Band | 20 |

Turn the amplifier on by placing the On/Off switch in the on position. The meter lights and blower should immediately come on. The amplifier is now in its two minute warm up cycle. During this warmup period, check for the following readings:

| | |
|---------------------------------|------------------------|
| Screen (Screen Current): | Zero |
| PV (Plate Voltage): | 3.0 KV to 3.3 KV |
| SV (Screen Voltage): | Approx. .35 KV (350 V) |
| IP (Plate Current): | Zero |

Place your transceiver in the CW mode or any mode that will provide a continuous carrier for tuneup. **At this time make sure that your transceivers output power level has been set to zero.**

TUNE UP PROCEDURE

Before making any tune up procedures, make sure your amplifier is connected to an appropriate load capable of handling at least 3,500 watts of power. Failure to do so may result in serious damage to your amplifier.

When the two minute warmup cycle has been completed, the red power light will turn on. The amplifier is now ready for tune up. At this point, place your transceiver in the SSB mode with the mic gain at minimum. Put the amplifier's Operate/Standby switch in the operate position. Key your transceiver and you should notice the green transmit LED on the amplifier lite. You should also hear the amplifier's internal relays latch. With the transceiver keyed and the amplifier's Multimeter switch in the IP position, observe the plate current (IP). ***It should be in the neighborhood of .500 - .600 amperes more or less.*** Also, your screen current should indicate a negative reading. In other words, it will move to the left. This is normal. Unkey your transceiver, and place the amplifier in the standby mode.

TUNEUP OBJECTIVE: The objective of the tuneup procedure is to bring the amplifier to resonance by adjusting the tune & load controls for the proper level of screen current. You will adjust tune control so the screen current peaks on the screen current scale. You will also adjust the load control to bring the screen to the proper level. When tuning on 160 meters and 80 meters, you may notice the screen current drift downwards. This is a result of the padder capacitors on the load side warming and changing their values. We are not concerned about an absolute steady state of screen current. We simply want you to get the screen current to peak on scale and adjust the load control for the specified level of screen current (75 mA). When re-keying after tuneup, the screen current may initially exceed 75 mA. This is OK because the screen current will reduce to 50 mA. The amplifier will go into the fault state if the screen current goes to a dangerous level.

1. Place your transceiver in CW mode, and set its output power level to 30 wattts for 160, 80, 40 meters and 20 wattts for 20, 15, 10 meters.
2. Place the amplifier in the operate position. **Initially, Put the Tune control at 50 and Load control at zero.**
3. Key your transceiver, and you should notice the screen current meter move to the left indicating negative current. Again, this is normal. Advance the loading control clockwise until you see a slight rise in screen current. **You may see the screen current dip to the left. Keep advancing the load control clockwise, and the screen current will continue to rise.**
4. Turn the tune control clockwise until the screen current reads 50 - 100 mA. If the screen current goes full scale, turn the tuning control counterclockwise until the screen current meter reads between 50 - 100 mA. If the screen current should rise to a dangerous level, the amplifier's protection circuit will place the amplifier into a fault state, and the red fault button light will come on. If this occurs, readjust the tune control counterclockwise, and push the fault light button to reset the amplifier, and start again.
5. Turn the load control counterclockwise, and the screen current should start to fall. Continue to turn the load control counterclockwise until the screen current reads 50 mA.
6. Turn the tune control clockwise until the screen current reads between 50 - 100 mA. Again, turn the load control counterclockwise until the screen current reads 25 mA. **Keep repeating this**

procedure until you see the screen current's maximum peak occurs somewhere on the screen current scale. Then, adjust the loading control counterclockwise (reduce) or clockwise (increase) until the screen current reads approximately 75 mA. You are now tuned to resonance for the input power applied. Again, on 160 meters and 80 meters the screen current may drift downward the longer you keep the amplifier keyed. We are not concerned about an absolute steady state of screen current on these bands. Simply adjust the tune control for a on scale screen current peak, and adjust the load control for a 75 mA reading.

7. Increase your drive power in 20 watt increments. With each increment repeat the procedure in item six until you have your desired level of power output.

REMEMBER THIS AMPLIFIER DOES NOT REQUIRE MUCH DRIVE POWER. SO START WITH LOW DRIVE POWER, AND THEN TUNE TO RESONANCE AS OUTLINED ABOVE. OTHERWISE, ARCING MAY OCCUR INSIDE YOUR AMPLIFIER.

***Ten Meter Operation:* Due to the high output capacitance of three GU74B tubes, the Q of the ten meter circuit is high. Thus, the efficiency and performance is not as good as the other bands. Heating will occur at the ten meter tap if high power operation occurs for extend period. Keep ten meter operation at 2,000 watts to avoid overheating.**

NEVER RUN YOUR AMPLIFIER FOR ANY SUSTAINED PERIOD WITH A SCREEN CURRENT READING GREATER THAN 75 MILLIAMPERES. IF YOU DO, DAMAGE AND FAILURE OF THE 4CX800A TETRODES WILL RESULT, AND THEY WILL NOT BE COVERED BY SVETLANA'S WARRANTY!

To facilitate your initial tune up, we have included a tune up chart. These settings and readings are into a 50 ohm dummy load. Your actual reading may vary do to any reactance in your antenna. Record your settings for future reference. You can control the power level of your voice peaks on SSB by advancing the ALC Control clockwise assuming you have the ALC line connected between your transceiver and amplifier.

TUNE-UP TABLE (50 Ohm Resistive Load) with 5 ohms of Cathode resistance.

| Frequency (MHZ) | Power Input | Tune | Load | Power Output | Screen Current | (IP) Plate Current |
|-----------------|-------------|------|------|--------------|----------------|--------------------|
| 1.80 | | | | | | |
| 1.90 | | | | | | |
| 3.60 | | | | | | |
| 3.90 | | | | | | |
| 7.20 | | | | | | |

| | | | | | | |
|--------|--|--|--|--|--|--|
| 14.20 | | | | | | |
| 18.10* | | | | | | |
| 21.30 | | | | | | |
| 24.90* | | | | | | |
| 28.50 | | | | | | |

***Transceiver's Tuner Used**

A Word About Wattmeters: The most reliable and accurate Wattmeters are either the Bird or Coaxial Dynamics thru feed. Wattmeters which use a ferrite core for r.f. sampling can be unreliable at high power levels. If you are using such a wattmeter and you observe an output level less than 1,500 watts for the values listed above, your wattmeter is probably not giving you an accurate reading.

Input SWR: The input SWR for 160 & 80 meters will be less than 1.5 :1. The input SWR for 40 meters should be around 1.5 :1 to 1.6 :1. Input SWR for, 20, 15, and 10 meters is at the most 1.5:1. These input SWR conditions should present no problem due to the lower drive power requirements of this amplifier. If you prefer a lower input SWR, use your transceiver's tuner to adjust for a better match.

WARC Band Operation: The HF-2500DX Mark III will operate on the WARC bands. You may need to use the transceivers internal tuner to provide a low input SWR on these bands. Use the following band positions: 17 Meters use 15 Meter position, 12 Meters use 10 Meter position. Once you have a low SWR reading using your transceiver's tuner, proceed with the tune up procedure outlined above.

SSB OPERATION: Some transceivers RF output (carrier level) control **DOES NOT** control the output power during SSB operation. If you have one of these transceivers and you go to SSB operation after initial the initial tune up procedure, your voice peaks may cause the screen grid current to go past full scale causing the amplifier to go into the fault state. You will have adjust your microphone gain or speech processor so the screen current and power output levels are within the specified levels. The ALC control can facilitate this procedure. It is normal to see some negative indication of screen current during SSB operation.

USING THE FRONT PANEL ALC CONTROL TO ADJUST AMPLIFIER OUTPUT POWER.

You may want to utilize an alternative to adjusting the drive power at the transceiver. The Front Panel ALC Adjustment Control allows you to adjust the ALC for the amount of output power you desire. Using this procedure, you would set the ALC Control to minimum (fully counter-clockwise). Tune the amplifier for maximum output. Then advance the ALC Control (clockwise) for the amount of output power you want. The ALC circuit of the amplifier supplies negative feedback voltage to the transceiver which reduces the amount of drive coming into the amplifier. **Only use this feature after your Amplifier has been properly tuned.**

PERIODIC MAINTENANCE

Make sure the Amplifier has been disconnected for the AC power source and the high voltage filter capacitors have bleed down to zero.

Remove the top cover from the Amplifier at least once a year and remove the dust. Dust accumulation can help cause the variable capacitors to arc between plates. Use the blower connection on a vacuum cleaner or a soft bristle brush. Also, remove the tubes from their sockets and check to see if any tarnish buildup has developed on the tube socket contacts. If so, use a Q Tip and Tarn-X solution, and clean each of the socket contacts.

TROUBLESHOOTING CHART

The following charts lists specific difficulties that could occur in your Linear Amplifier. Several possible causes may be listed for each difficulty. Refer to the Printed Circuit Board diagrams (PCB) and the Schematic Diagrams to locate and identify the parts listed in this chart. If a particular part is mentioned as a possible cause, check that part and other components connected to it to see if they are defective. **AS ALWAYS, BE SURE THE AMPLIFIER POWER CORD HAS BEEN REMOVED FROM THE AC LINE RECEPTACLE AND THE HIGH VOLTAGE FILTER CAPACITORS HAVE BLED DOWN TO ZERO VOLTS BEFORE REMOVING THE TOP COVER FOR YOUR INSPECTION.**

| DIFFICULTY | POSSIBLE CAUSE |
|--|--|
| No AC power | <ol style="list-style-type: none"> 1. Fuse F1 or F2 rear panel 2. Jumpers missing on Terminal Block TB1 3. Transformer T1 4. On/Off Switch SW2A or SW2B 5. Interlock Safety Switch SW1 6. Solid State Relays SR1 or SR2 or related circuitry |
| Multimeter inoperative in High Voltage Function | <ol style="list-style-type: none"> 1. Resistors R210, R211, R212, R213 High Voltage Diode PCB 2. Multimeter Switch SW501A or SW01B Meter Switch PCB 3. M-1 Multimeter 4. Transformer T-1 Secondary 5. Component failure on HV Diode or HV Capacitor PCB |
| Multimeter inoperative in Plate Current Function | <ol style="list-style-type: none"> 1. Resistors R311 LV & Bias PCB 2. Switch SW401A&B Meter Switch PCB 3. M-1 Multimeter 4. F303 2 Ampere Fuse |

| | |
|---|--|
| <p>Multimeter inoperative in Screen Voltage Function</p> | <ol style="list-style-type: none"> 1. Components on Screen Supply PCB <ol style="list-style-type: none"> a. Capacitors C401 or C402 b. Diodes D401, D402 c. Resistors R405, R406, R407, R408 d. Zener Diodes ZD401 - ZD404 e. Fuse F401 2 Ampere Fuse 2. Switch SW401A&B Meter Switch PCB-510 3. M-1 Multimeter 4. Transformer T-1 Secondary |
| <p>Plate idle current over 500 - 600 mA</p> | <ol style="list-style-type: none"> 1. Components on LV & Bias PCB <ol style="list-style-type: none"> a. Zener Diodes ZD301 b. Relay K4 |
| <p>Plate Current does not read zero in standby mode</p> | <ol style="list-style-type: none"> 1. Components on LV & Bias PCB <ol style="list-style-type: none"> a. D307 Bridge Rectifier b. C311 Electrolytic Capacitor c. Relay K4 d. Fuse F301 2 ampere |
| <p>No Plate idle current</p> | <ol style="list-style-type: none"> 1. Components on LV & Bias PCB <ol style="list-style-type: none"> a. Fuse 303 2-1/2 Ampere b. Shunt Resistor R311 2. Screen Supply PCB component failure |
| <p>Meter Lamps do not light</p> | <ol style="list-style-type: none"> 1. Components on LV & Bias PCB <ol style="list-style-type: none"> a. Fuse F302 b. Bridge Rectifier D306 c. Capacitors C307, C308, C309 d. +12v Regulator U2 2. Associated +12v Supply wiring 3. Meter Lamps PL1 - PL4 Meter Switch |
| <p>Amplifier will not key when transceiver is keyed to transmit</p> | <ol style="list-style-type: none"> 1. Components on LV & Bias PCB <ol style="list-style-type: none"> a. Fuse F301 b. Bridge Rectifier D302 c. Capacitor C301 2. Components on RF I/O Switching PCB-350 3. Operate Standby SW4 Front Panel |

| | |
|---|--|
| <p>Amplifier will not key when transceiver is keyed to transmit</p> | <ol style="list-style-type: none"> 1. Components on LV & Bias PCB-260 <ol style="list-style-type: none"> a. Fuse F301 b. Bridge Rectifier D301 c. Capacitor C301 2. Resistors R305, R306 3. Operate/Standby SW4 Front Panel 4. Components on RF I/O Switch PCB <ol style="list-style-type: none"> a. R601, R603, R604, R606, R607 b. Relay RY1 c. C601, C602 d. D601, D602, D603 e. Q601 |
| <p>ALC Inoperative</p> | <ol style="list-style-type: none"> 1. Improper connection between transceiver and amplifier 2. POT R13 (ALC Adjust) on front panel 3. Components on RF I/O Switch PCB <ol style="list-style-type: none"> a. C608, C609, C610 b. R608 c. D604, D605 |
| <p>No RF Output</p> | <ol style="list-style-type: none"> 1. Improper connections between transceiver, amplifier, and antenna 2. Transceiver and amplifier are set to different bands 3. Improper Tuned Input adjustment 4. Defective RF I/O Switching PCB 5. Defective RF Output T/R Relay RY1 6. Defective Band Switch SW3A, SW3B 7. Defective Input Band Switch SW3A |
| <p>Grid Trip Circuit Inoperative</p> | <ol style="list-style-type: none"> 1. Defective Trip Reset Switch SW6 2. Components on LV & Bias PCB <ol style="list-style-type: none"> a. R305 b. Relay K1 c. Relay K5 d. R310, C317, C318, D310, D311, Q2 |
| <p>Red Power LED not functioning</p> | <ol style="list-style-type: none"> 1. +12 VDC supply located on LV & Bias PCB related wiring 2. LED D1 defective 3. Relay K3 |
| <p>Green Transmit LED not functioning</p> | <ol style="list-style-type: none"> 1. +12 VDC supply located on LV & Bias PCB related wiring 2. LED D2 defective 3. Relay K2 and related keying circuitry |

| | |
|---|--|
| Two minute warmup cycle not functioning | Components on LV & Bias PCB 1. U3 555 Timer and related components 2. Transistor Q1 3. K3 Relay |
|---|--|

CIRCUIT DESCRIPTIONS

Refer to the Appropriate Schematic Diagrams and PCB Layouts while you read the following paragraphs.

POWER SUPPLY

Power transformer T1 supplies the power required to operate the Linear Amplifier. A dual-winding primary allows the amplifier to be operated from 200 VAC or 240 VAC. Two 20 ampere fuses protect the transformer against overload. Capacitors C10 & C11 provide AC line bypassing. This amplifier uses a special combination safety interlock/solid state relay circuit. Interlock switch SW1, On/OFF power switch SW2A&B must be closed before power is supplied to the primary of transformer T1. Solid State Relays SR1 & SR2 provides a soft start when the amplifier is switched on. They only turn on when the AC line voltage crosses the zero degree point of the sine wave Terminal Block TB1 allows for the selection of the line voltage to be used. See the Terminal Block Wiring Diagram for the correct wiring. Cooling Fan B1 is provided 100/120 VAC by connection across only one of the primary windings at TB1. B1 always operates on 100/120 VAC regardless of which AC line voltage is used. Switch SW4 in combination with resistors R307A & R307B provide a high or low setting for the fan. The secondary windings of T1 provides the following secondary voltages: 2,400 VAC Plate Voltage Supply & 124 VAC Screen Voltage Supply.

PLATE VOLTAGE

The 2400 VAC output of T1 is connected to a full-wave bridge rectifier circuit consisting of the components on HV Capacitor PCB and HV Diode PCB. Diodes D101 - D120 rectify the secondary AC voltage and capacitors C200 - C207 filter this voltage. Capacitors C101 - C120 are connected across the diodes to protect them against transients. Resistors R200 - R207 are connected across the filter capacitors to equalize the voltage drop across each capacitor. These resistors also act as bleeder resistors for the filter capacitors to discharge them when the amplifier is turned off. One of the red 2400 VAC secondary leads is connected to the junction of D101 & D106, and the other red 2400 VAC secondary lead is connected to the junction of D111 & D116. During the AC line cycle when the lead at D101 & D106 junction is positive, diodes D101 - D105 & D111 - D115 conduct and capacitors C200 - C207 are charged. During the other half of the AC line cycle, the red lead connected to the junction of D111 & D116 becomes positive. Capacitors C200 - C207 charge and Diodes D106 - D110 & DD116 - D120 conduct. The capacitor bank charges to the peak voltage of the 2200 RMS VAC secondary voltage ($2400 \text{ VAC} \times 1.414 = 3,393.60 \text{ VDC}$).

Resistor R209 is a protection resistor connected in series with the Plate Voltage Circuit. If a short develops, this resistor prevents the B- from rising to the B+ potential. Thus providing protection

for all the components within the B+ circuit including the 4CX800A tetrodes. Resistors R110 - R113 & R212 - R215 are discussed under Metering Circuits.

TUBE FILAMENTS

The 12.6 VAC secondary windings on T2 secondary supplies 8 amperes for the amplifier's tube filaments. The 4CX800A tetrodes are indirectly heated cathodes, and the tube filaments must heat them for an initial two minute warmup period.

12 VAC SUPPLY

The 12 VAC secondary winding of T2 supplies the voltage for the +12 VDC supply circuit located on the LV & Bias PCB. +24 VDC is also produced on the LV & Bias PCB using a voltage doubler circuit using this 12 VAC supplied by T2.

120 VAC ISOLATION SUPPLY

The 120 VAC secondary winding of T2 provides an isolated supply voltage for the +120 VDC power supply located on the LV & Bias PCB. This supply uses a bridge rectifier diode to rectify the voltage along with a filter capacitor. The +120 VDC power supply provides the voltages for the internal T/R switching plus the tube grid bias.

CONTROL GRID BIAS

A cutoff bias voltage of -160 V is supplied by circuit consisting of bridge rectifier D307, capacitor C311. The transmit -70 to -80 V bias is supply by these components along with zener diodes ZD301, resistor R304 when relay K4 has been engaged by the T/R circuit.

SCREEN GRID BIAS

The Screen Supply PCB develops the screen grid bias of +350 volts. The secondary of T1 supplies 124 VAC. Diodes D401 & D403 along with capacitors C401 & C402 form a voltage double circuit. These capacitors charge to 2.828 times the supplied rms 124 VAC ($124 \times 2.828 = 350$). Zener diodes ZD402 - ZD404 regulate the output voltage. Resistors R402 & R403 are the bleeder resistors for Capacitors C401 & C402.

RF INPUT CIRCUITS

When the amplifier is in the Stanby Mode (receive), Relay RY1 and Relay RY2 (located on the RF I/O Switching PCB) are in their normally open state. Thus, RF energy supplied from the transceiver passes through RF Input Connector (J2), RY2, RY1, and RF Output Connector (J1) to the antenna. The amplifier has been bypassed. Capacitors C70 & C71 tune the mismatch that occurs with the relay contacts located inside RY1 & RY2. When the amplifier has been keyed (Transmit Mode). RY2 closes and the RF energy supplied by the transceiver passes though RY2's closed contacts to relay RY3. If you have selected 160, 80, or 40 meters on the band selector switch SW3, the signal passes through normally open contacts and to R607 the 50 ohm

100 watts input swamping resistor. R607 is connected to ground. The rf signal is supplied to the control grid of the tubes at the input point of swamping resistor R607. Coupling capacitors C57 & C58 located at the tube control grids isolates the tubes from the input circuit. If you have selected 20, 15, or 10 meter on the band selector switch CW3, relay RY3 goes to its normally closed position. Depending on the band you have selected, one of the following relays will latch to their normal open state. Then a necessary amount of reactance is applied to cancel the capacitive input reactance of the tubes. The rf signal then goes to RY3 and on to the R607 swamping resistor and the tube control grids as outlined above.

TUBES

The amplifier's tubes are connected in a class AB1 grounded cathode circuit. RF driving power is applied to the control grids in the normal grid driven configuration. Pins 2, 6, and 6 of the tubes are internally connected together and are connected B- circuit. The B-1 circuit is not at chassis ground. Pins 3 & 7 are connect to the filament supply. Pins 1 are connected to the rf input and grid bias circuit. Pins 5 are connected to the screen bias supply circuit. Parasitic chokes PC1, PC2, & PC3 are connected to the plate lead to suppress any VHF parasitic oscillations. The positive side of the power supply (B+) is connected to the tube's plate through RFC3 (Plate Choke). Capacitor C56 provides a low impedance path to ground for any RF energy that may get through RFC3. Capacitors C54 & C55 are DC blocking capacitors. They allow the RF signal to enter the output tank circuit, and they block the DC high voltage from entering the tank circuit. Fan B1 circulates cooling air through the cooling anode fins of the tubes.

RF OUTPUT CIRCUITS

The tuned output circuit of the Amplifier is a pi-network using a 4:1 transformer (L3). The pi circuit transforms the plate load impedance down to 200 ohms. The 4:1 transformer further transforms the 200 ohms down to 50 ohms. L3 has a secondary function to provide a broadband L coil for harmonic suppression. It is always at DC ground potential. Therefore, L3 will prevent high voltage from going to your antenna if the blocking capacitors C53 & C54 should short. The positive high voltage would go to dc ground causing the line fuse to blow which would shut the amplifier down. Band Switch SW3C progressively shorts out the unused portions of tank coils L1 & L2. The tank coil turns in use are tuned to resonance by Tune Capacitor C51. Load Capacitor C50 is tuned to complete the impedance match between the tube and the 4:1 transformer L3. Transformer L3 is then connected to RF Output connector J1 through T/R relay RY1. Capacitor C52 & C53 provides additional capacitance for C51 on 80 & 160 meters. Capacitors C54 & C55 provides additional capacitance for C50 on 160 & 80 meters. Again, if DC plate voltage should enter the tank circuit due to a short in either DC Blocking Capacitors C54 & C55, the DC voltage has a path to ground through the 4:1 Xfmr (L3). This will short-circuit the high voltage supply which will blow the AC line fuses. Also, DC plate will be prevented from entering the Antenna.

ALC CIRCUIT

ALC Adjust Control (R13) located on the front panel allows you to set the ALC threshold to match your Transceiver. Capacitors C608 & C609 form a voltage divider that couples some of the RF

driving voltage to Diodes D604 & D605. When the RF driving voltage exceeds the ALC threshold, the diodes rectify the negative half cycles. Capacitor C610 filters and bypasses this voltage, while resistor R608 provides isolation. The negative voltage appearing at ALC Output connector (J5) is coupled back to the transceiver to control its gain and reduce "flat topping" voice peaks due to overdrive. This allows you to control the output of your transceiver without reducing your transceiver's drive.

SCREEN GRID METER CIRCUIT

Screen grid current meter M-2 provides an indication of screen grid current between 0 and 150 milliamperes. The screen grid current meter is connected in parallel with shunt resistors R07 & R308 located on the LV & Bias PCB. The screen grid return circuit is through the cathode circuit (B-). Diodes D308 & D309 plus capacitor C314 provides M-2 with transient protection.

PV (PLATE VOLTAGE) MULTIMETER CIRCUIT

When you select this function with switch SW501 located on the Meter Switch PCB, resistors R110 - R113 located on the HV Diode PCB form a voltage divider to measure plate voltage. Resistors R110 - R112 form a series multiplier resistance for meter M-1 while resistor R1131 forms a current shunt for the meter. Diodes D1 & D2 plus capacitor C75 provides M-1 with transient protection.

IP (PLATE CURRENT) MULTIMETER CIRCUIT

When you select this function with switch SW501 located on the Meter Switch PCB, meter M-1 indicates the plate current drawn by the tubes between 0 and 2.80 amperes. It is switched in parallel with resistors R311 located on the LV & Bias PCB. The voltage drop across this resistor is measured. The meter scale is calibrated to indicate the plate current by using the fixed parallel resistance value of R311 and the voltage across them.

SV (SCREEN VOLTAGE) MULTIMETER CIRCUIT

When you select this function with switch SW501 located on the Meter Switch PCB, resistors R212 - R 215 located on the HV Capacitor PCB form a voltage divider to measure plate voltage. Resistors R212 - R214 form a series multiplier resistance for meter M-1 while resistor R215 forms a current shunt for the meter.

RF I/O SWITCHING PCB AND BIAS RELAY SWITCHING CIRCUITS

All RF T/R relays (RY1 & RY2) and bias relay (K4) are connected in series in the amplifier keying circuit. The switching voltage is supplied by the +120 VDC 80 milliampere supply located on the LV & Bias PCB. This circuit includes bridge rectifier D301 & filter capacitor C301. The +160 VDC output is fed to voltage divider resistors R305 & R306 which are surface mounted on the chassis. +110 VDC keying voltage is dropped across resistor R306 and fed back to R301 and R302 located on the LV & Bias PCB. 12 volts is dropped across relays K1 and K2. The remaining +98 VDC is passed to RY1 and R601 located on the RF I/O Switching PCB. 24 volts is dropped across R602 and RY1. 12 VDC is then dropped across RY2 and R603. The remaining +62 VDC is dropped across resistor R604. Capacitor C601 and resistors R601 & R602 plus diode D602

form a break make delay circuit for RY1 & RY2. This helps to make the proper latching and unlatching sequence for relays K301, RY1, and RY2. Transistor Q601 plus associated components form a electronic switch to key the Amplifier utilizing +15 VDC on transmit supplied by the transceiver through connector J4. The Amplifier can also be keyed by sinking the 80 milliamperes to ground through connector J3 and the transceiver's keying relay. The Operate/Standby Switch SW4 located on the front panel must be closed for the keying circuit to work. Otherwise the amplifier will be bypassed.

SCREEN GRID PROTECTION CIRCUIT

The screen grid protection circuit consists of the following components located on the LV & Bias PCB: R305, C312, K1, R310, C317, C318, D310, D311, Q2 K3. When screen current flows, a voltage drop develops across R305. If the current flow is large enough to cause a voltage drop sufficient enough to latch relay K1, a +24 volts is delivered to the base of Q2 through resistor R310. This causes Q1 to conduct causing relay K5 to latch. This breaks the VOX line causing the amplifier to go into a bypass state. Cutoff bias is supplied to the tubes, and the input rf signal is removed from the grids of the tubes. K5 also supplies +24 volts to the grid trip light located in the Fault reset switch (SW6) located on the front panel. When switch SW6 is pressed, a break in the + 24 volt circuit occurs. This causes K5 to reset which reconnects the VOX line.

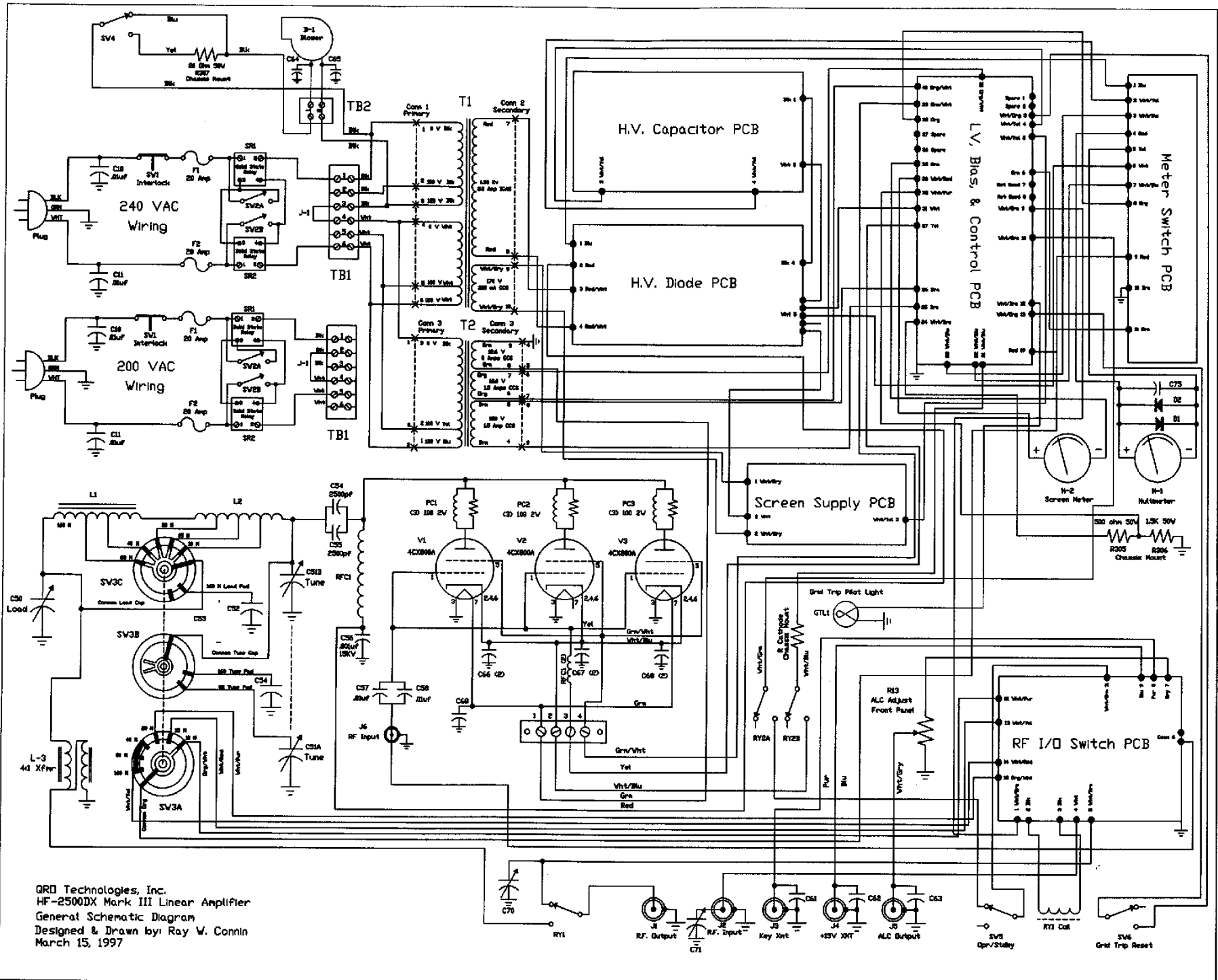

GRD Technologies, Inc.
 HF-2500DX Mark III Linear Amplifier
 General Schematic Diagram
 Designed & Drawn by Ray W. Conlin
 March 15, 1997

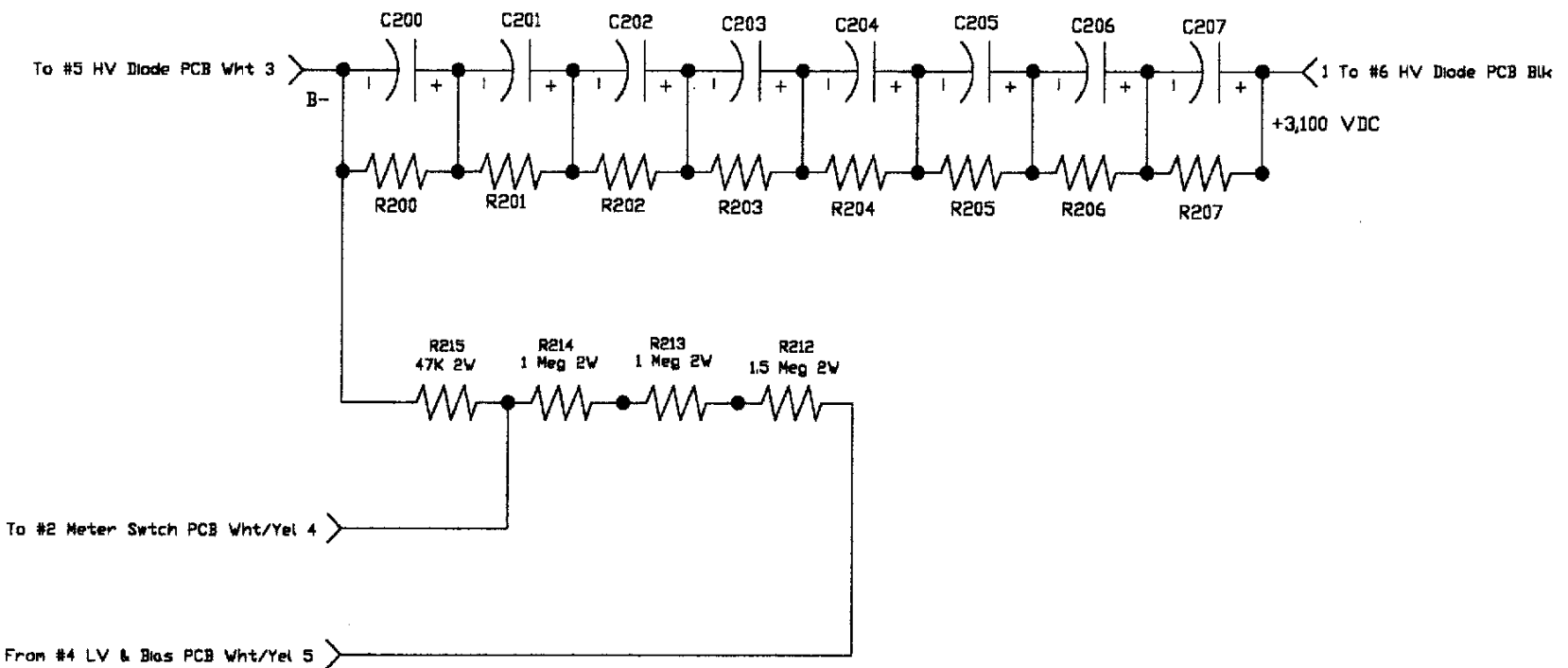

C200 - C207 470uf 450V
 R200 - R207 50K 5W

GRD TECHNOLOGIES, INC.
 HV Capacitor PCB
 Model: HF-2500DX/HF-3KDX
 Part No: 06111
 Drawn by: Ray W. Conlin
 October 8, 1995
 Rev. 1: 5/7/96

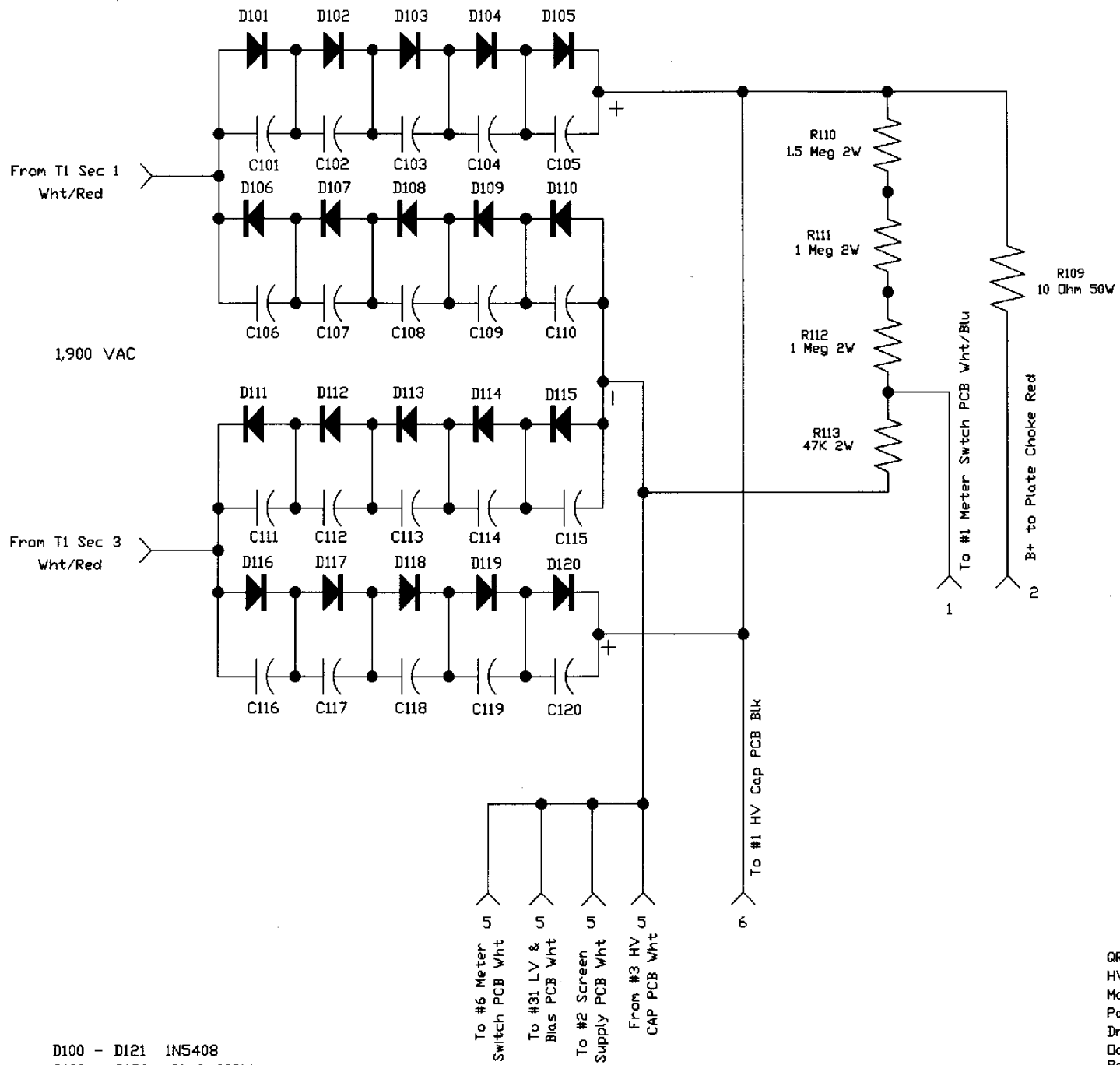

D100 - D121 1N5408
 C100 - C120 .01uF 600V

GRD TECHNOLOGIES, INC.
 HV Diode PCB
 Model: HF-2500DX/HF-3KDX
 Part No: 06112
 Drawn by: Ray W. Connin
 October 8, 1995
 Rev. 2: 03/01/00

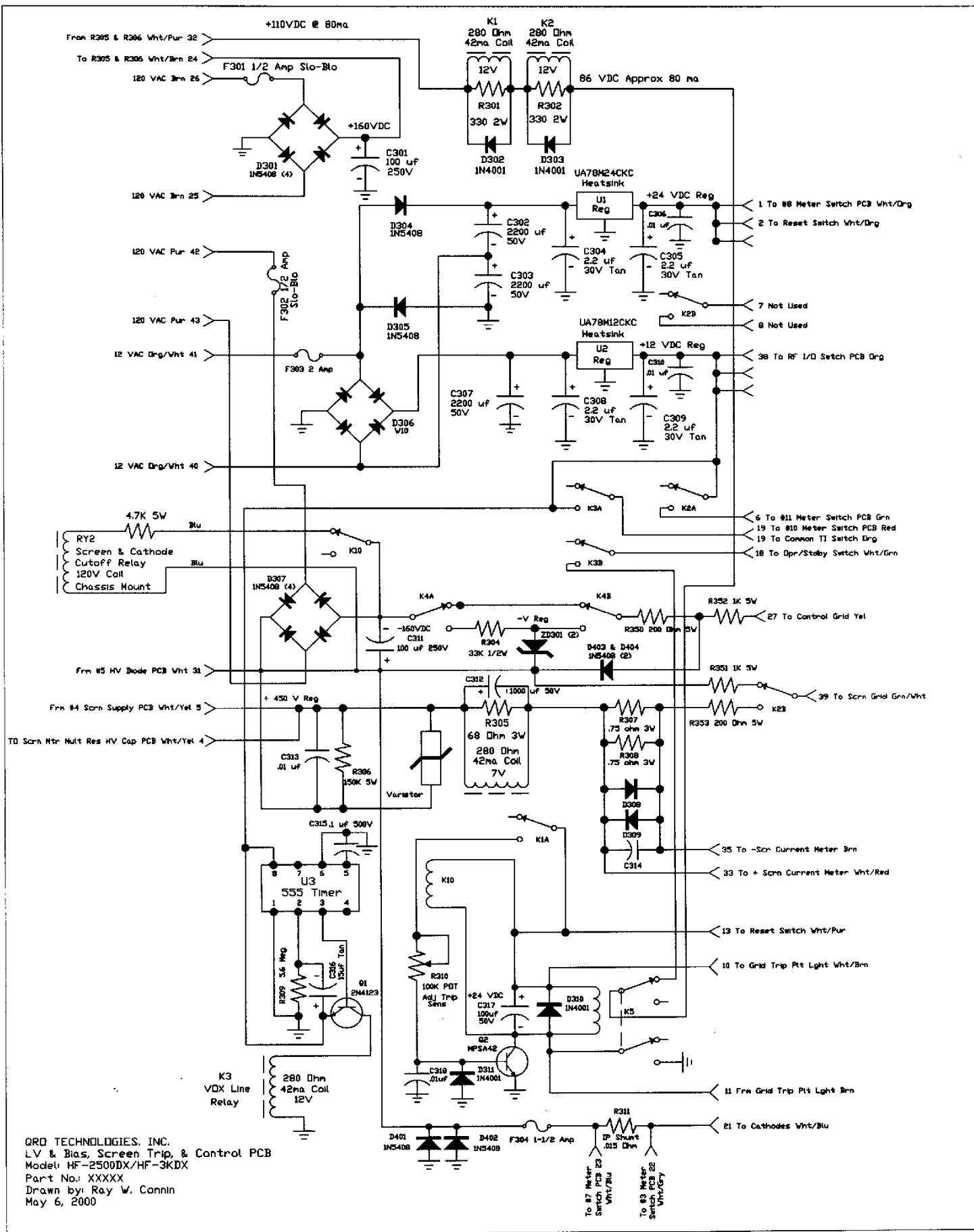

GRD TECHNOLOGIES, INC.
 LV & Bias, Screen Trip, & Control PCB
 Model: HF-2500DX/HF-3KDX
 Part No: XXXXX
 Drawn by: Ray W. Connin
 May 6, 2000

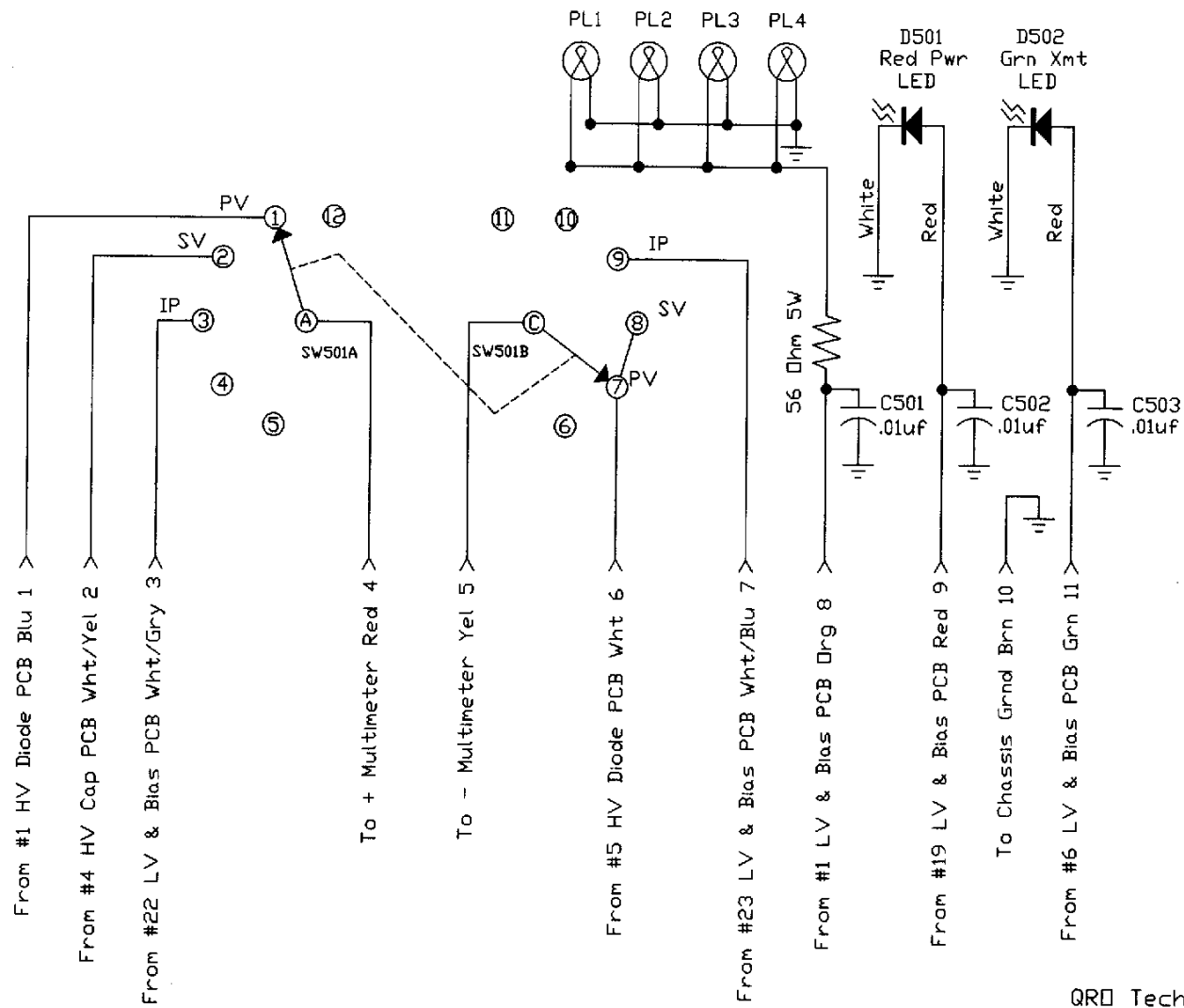

QRD Technologies, Inc.
 Meter Switch PCB
 Model HF-2500DX/HF-3KDX
 Part No.: 06113
 Drawn by: Ray W. Connin
 October 18, 1995
 Rev. 2: 02/10/97

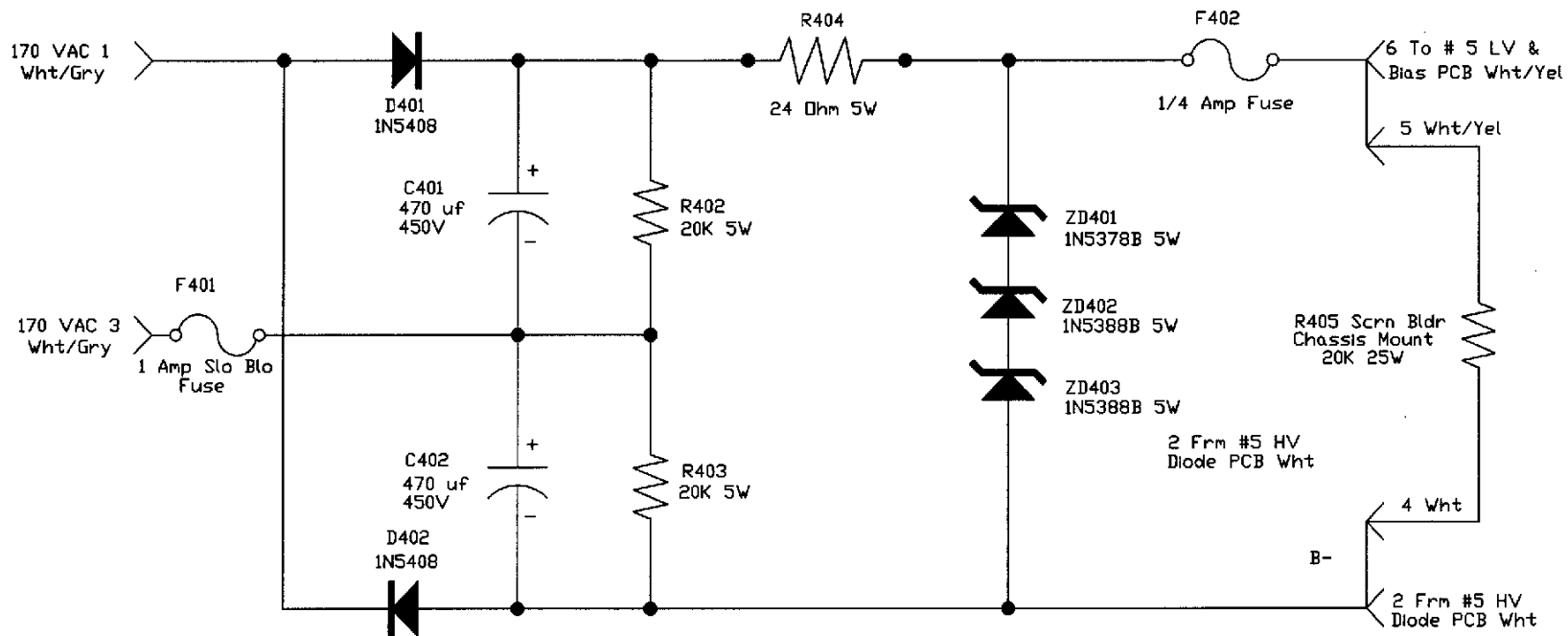

QRD TECHNOLOGIES, INC.
 Screen Supply PCB
 Model HF-2500DX/HF-3KDX
 Part No. 06130
 Drawn by: Ray W. Cannin
 March 17, 2000

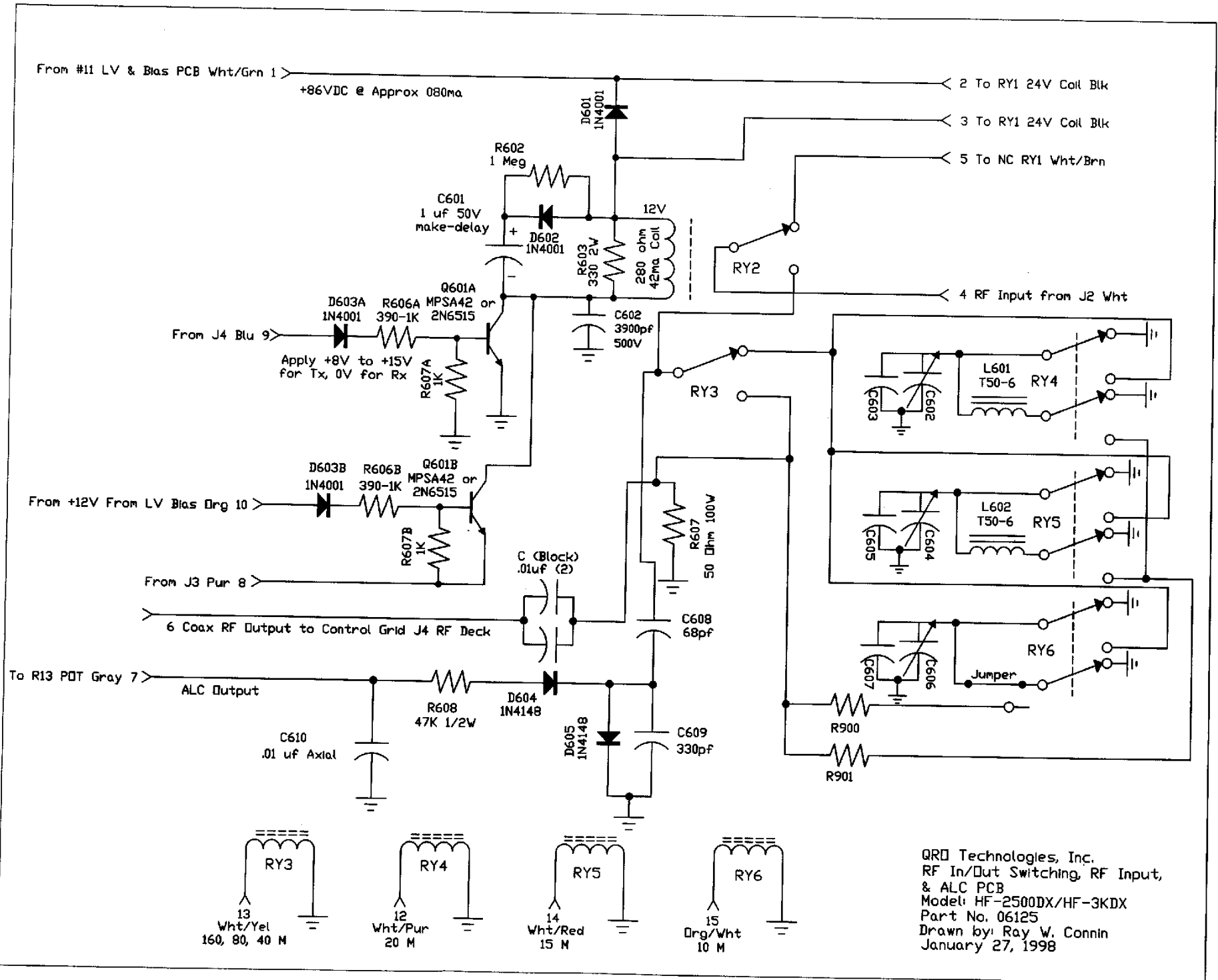

GRQ Technologies, Inc.
 RF In/Out Switching, RF Input,
 & ALC PCB
 Model: HF-2500DX/HF-3KDX
 Part No. 06125
 Drawn by: Ray W. Connin
 January 27, 1998

5 To #4 LV & Bias PCB Wht/Yel 10"

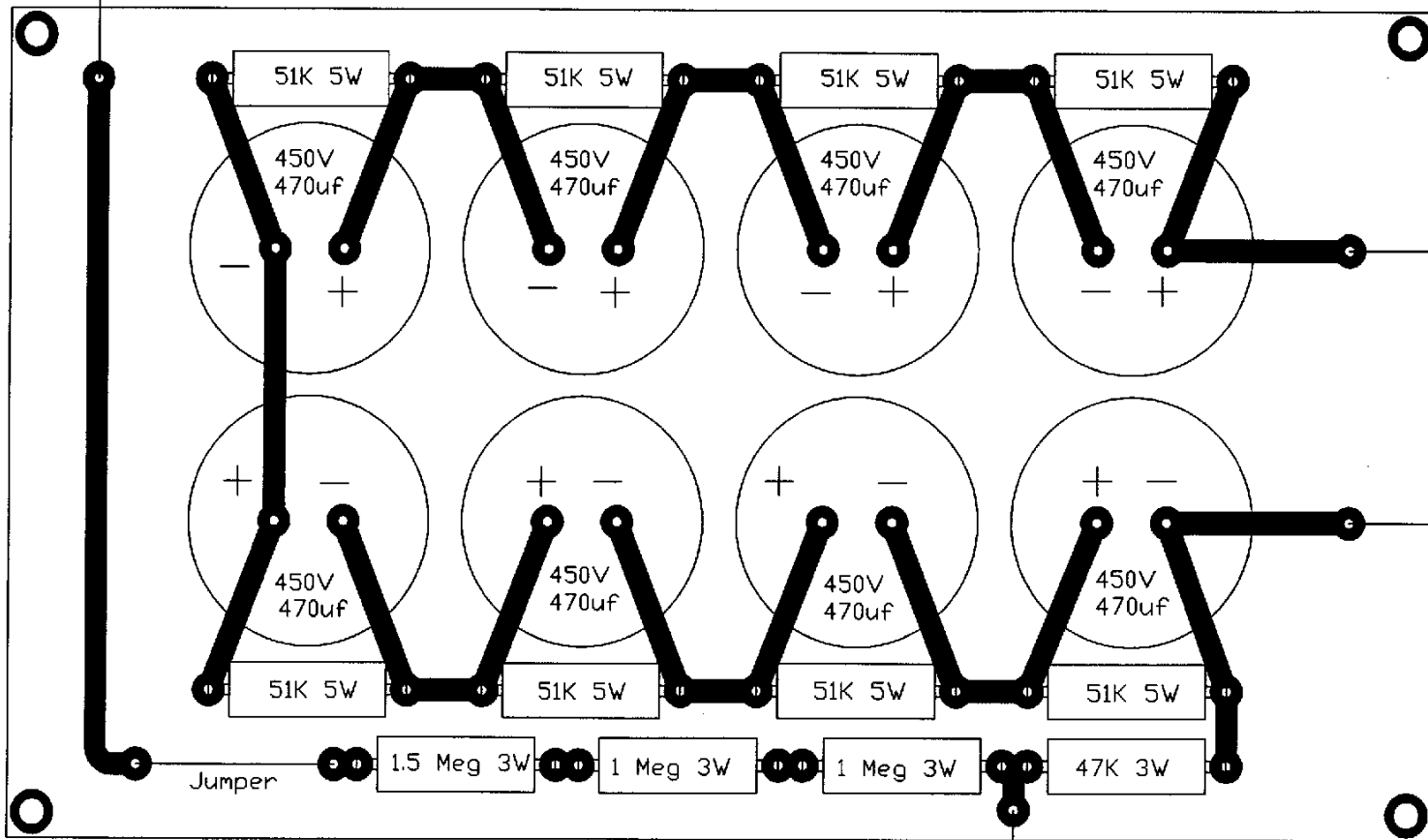

QRD Technologies, Inc.
H.V. Capacitor PCB
Model: HF-2500DX/HF-3KDX
Part No. 06111
Ray W. Connin
October 22, 1995
Rev. 2: 10/29/99

1 To #6 HV Diode
PCB Blk 6"

3 To #5 HV Diode
PCB Wht 6"

4 To #2 Meter Switch PCB Wht/Yel 17"

Note: All holes .0625 dia.
Four Corner Holes .1875 dia

HF-2500DX Amplifier

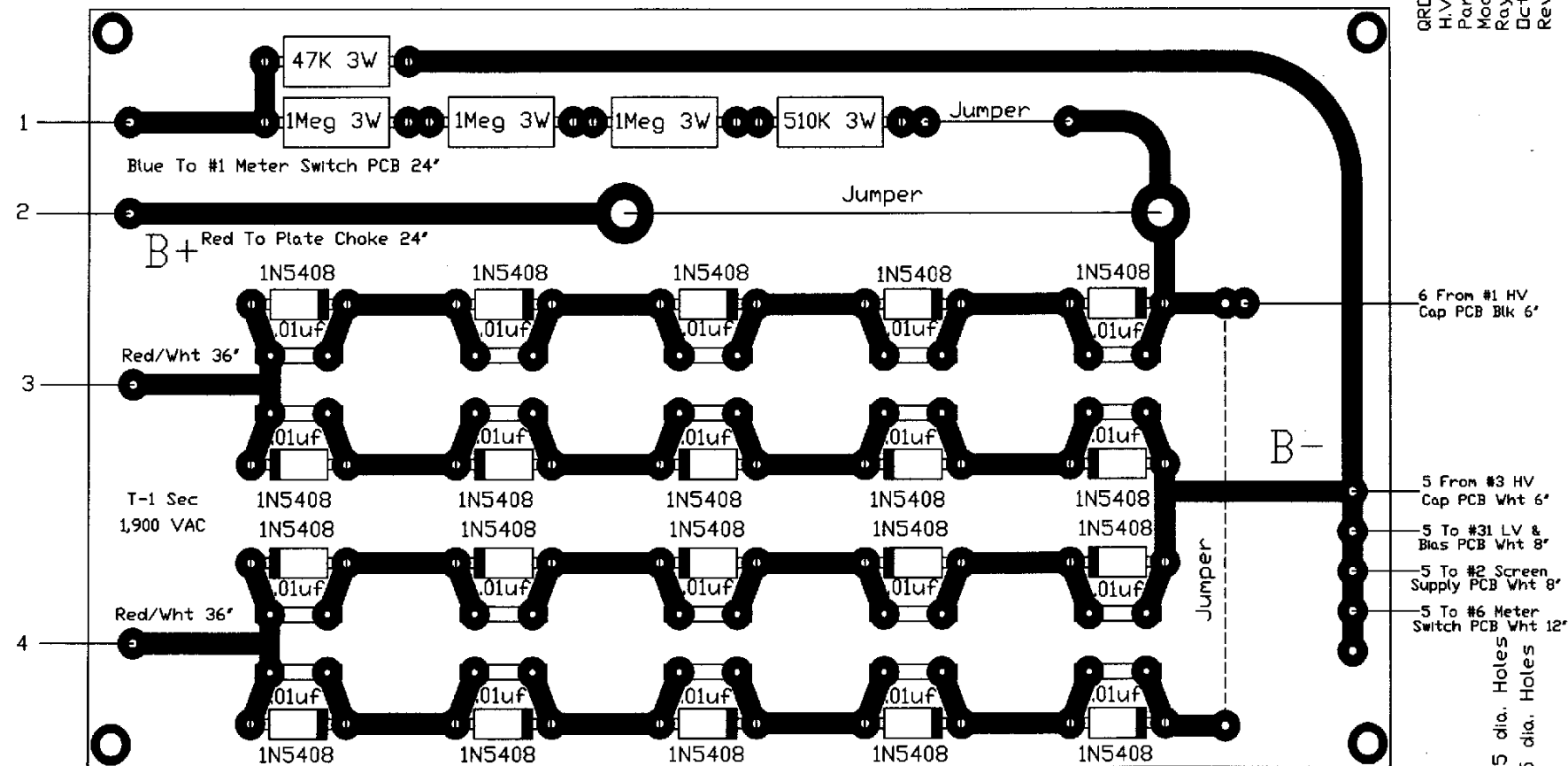

QRD Technologies, Inc.
 H.V. Diode PCB
 Part No. 06112
 Model: HF-2500DX/HF-3KDX
 Ray W. Conlin
 October 22, 1995
 Rev. 3: 09/24/01

Note: Blue Pads .0625 dia. Holes
 Red Pads .1875 dia. Holes

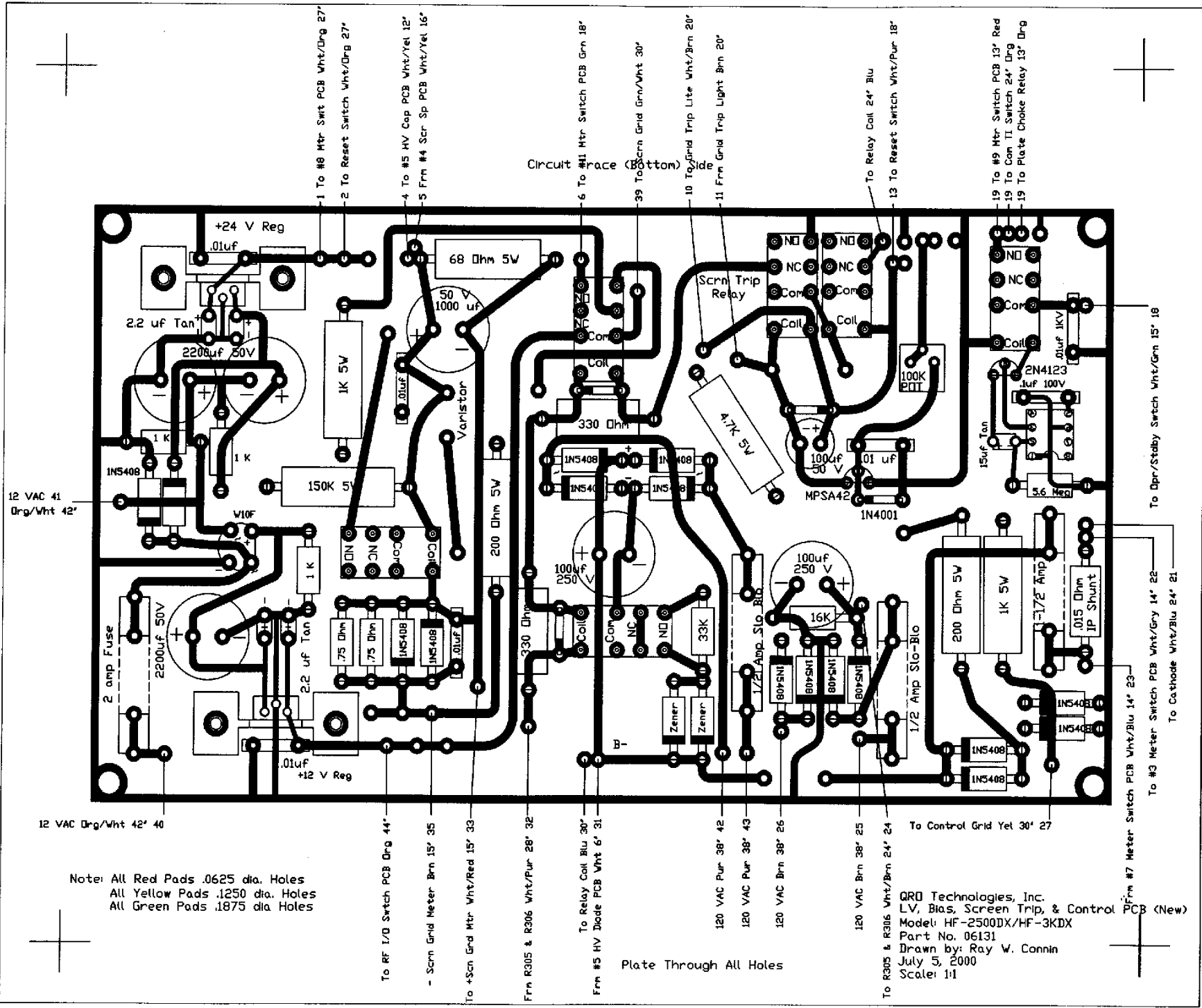

Note: All Red Pads .0625 dia. Holes
 All Yellow Pads .1250 dia. Holes
 All Green Pads .1875 dia. Holes

Plate Through All Holes

GRD Technologies, Inc.
 LV, Bias, Screen Trip, & Control PCB (New)
 Model: HF-2500DX/HF-3KDX
 Part No. 06131
 Drawn by: Ray W. Connin
 July 5, 2000
 Scale: 1:1

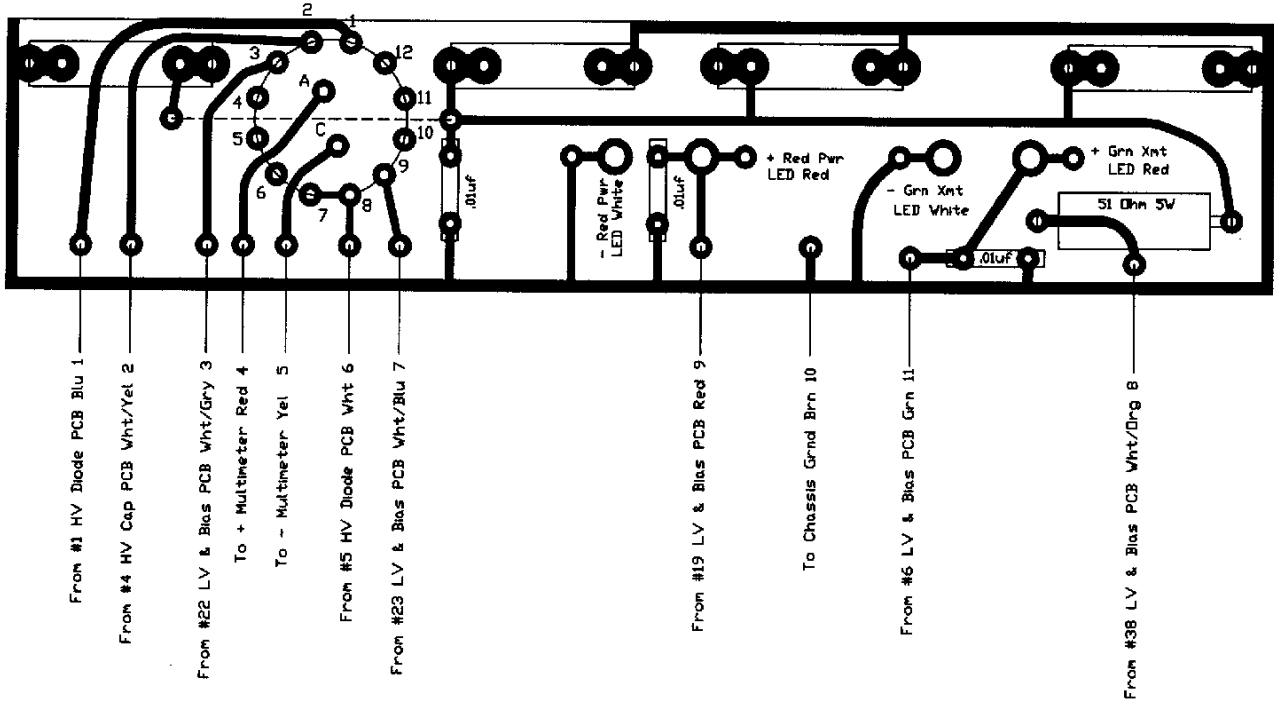

Note: All small holes .0625 dia.
 All large holes .1250 dia.

GRD Technologies, Inc.
 Meter Switch PCB
 Part No. 06113
 Model: HF-2500DX/HF-3KDX
 Ray W. Connin
 October 23, 1995
 Rev. 2: 02/10/97

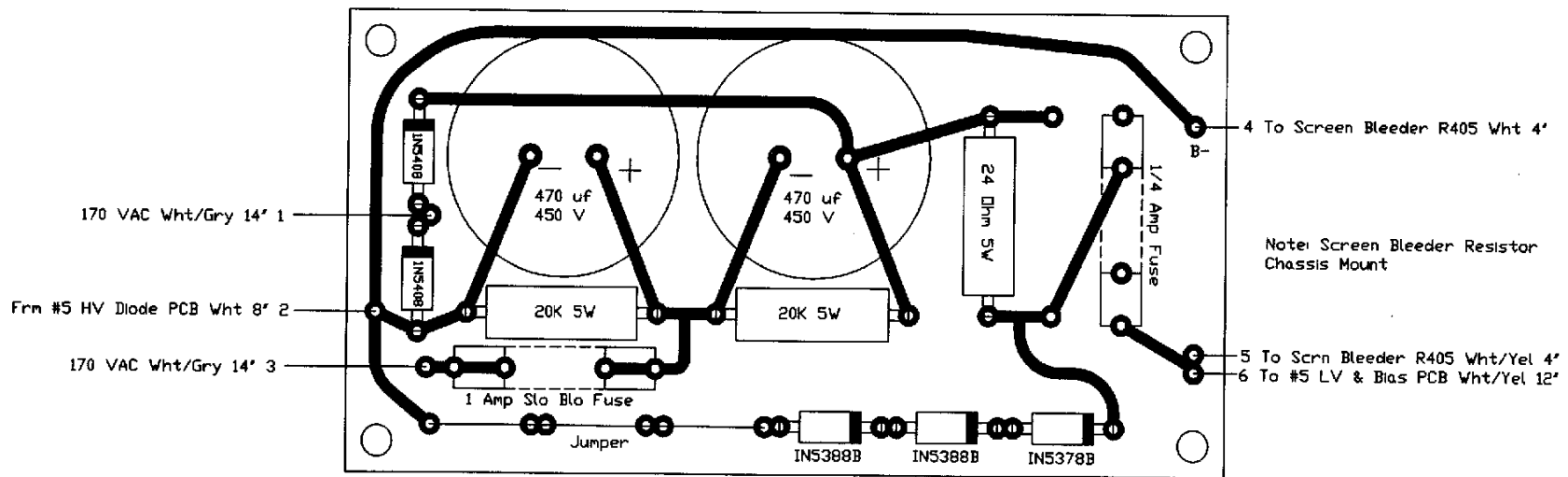

Note: All Trace Holes .0625 dia.
Four Corner Holes .1875 dia

GRQ Technologies, Inc.
Screen Supply PCB
Model: HF-2500DX/HF-3KDX
Part No. 06130
Drawn by: Ray W. Connin
March 17, 2000

Circuit Trace
Foil Side

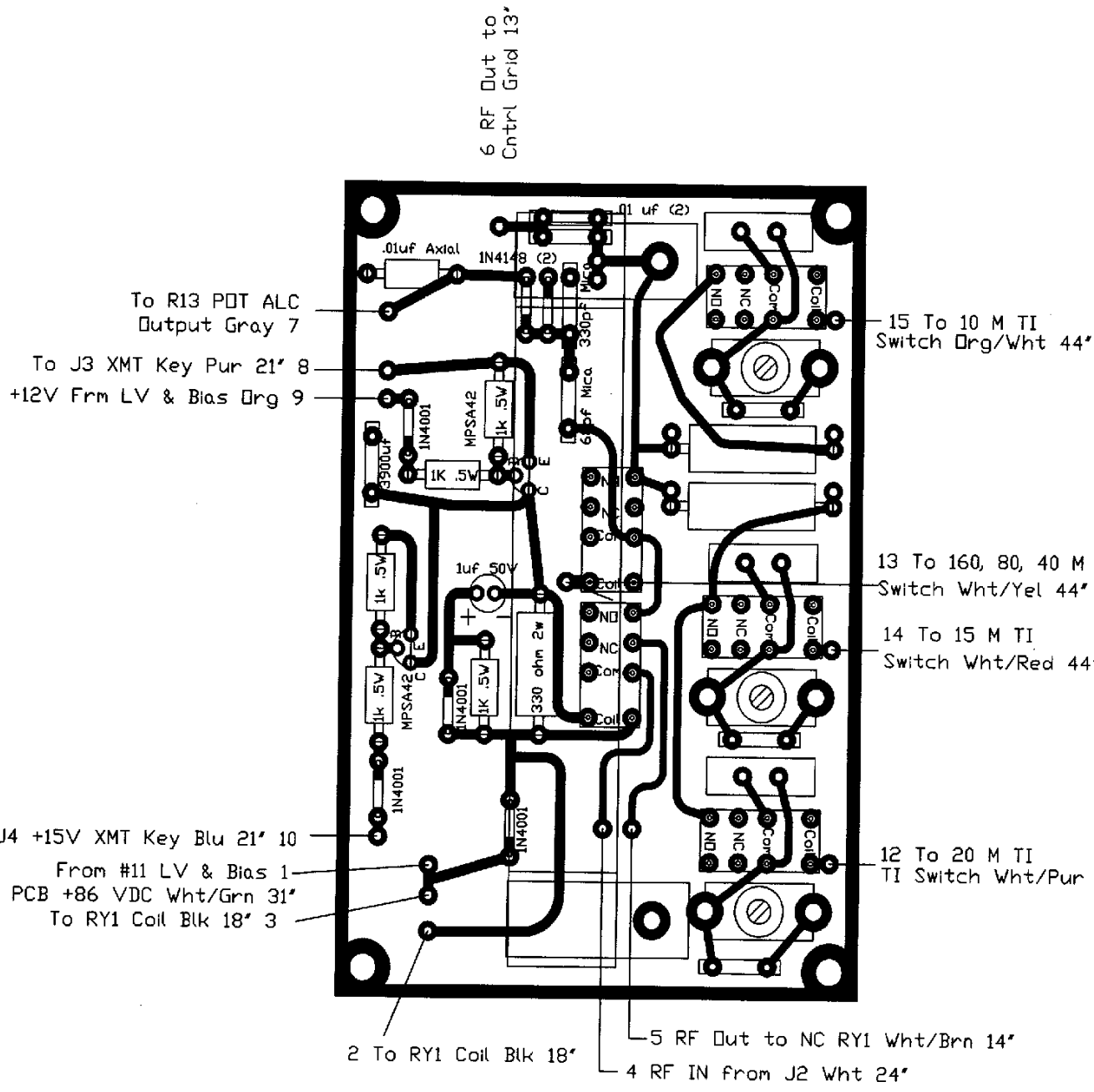

GRD Technologies, Inc.
RF I/O Switching, RF Input,
& ALC PCB
Model: HF-2500DX/HF-3KDX
Part No. 06125
Drawn by: Ray W. Conlin
January 27, 1998
Rev. 1: 04/28/98

Note: All Small Holes .0625 Dia.
All Medium Holes .1250 Dia.
All Large Holes .1875 Dia.
Four Corner Holes .1875 Dia.