

KL503

HF 21—30 MHz Linear Amplifier



Ver 1.0 Apr. 2019

Specifications:

Operation Frequency:	21—30 MHz (15/12/10m Amateur HF Bands)
Modulation Types:	SSB,CW,AM, FM, (All narrowband modes)
Transistor:	8x RM 3 1x RM 4 MOSFET
Max I/P Current:	32A
Power Supply:	13.8VDC+/- 1V 40A
Input Fuse (Internal):	3x10A (Auto Fuse)
Input RF Power:	1-6W max (All modes)
Output RF Power:	300W max
Maximum bypass power (Amplifier off):	50W max
Input VSWR:	1.1—1.5:1

WARNING: Before using this product please read carefully all of the information in this manual or at least the quick start guide!!! To avoid damage or incorrect operation this is extremely important!!!

Quick Start Guide:

A more complete guide to the installation is featured later

- 1. Connect the RTX input connector to transceiver with 50 Ohm patch cable**
- 2. Connect the ANT Output of the Amplifier to SWR Bridge / Wattmeter (If required), and then the Antenna (50 Ohm load Impedance)**
- 3. Connect the Amplifier DC power Cable to a suitable 13.8VDC ($\pm 1V$) 40A Power Supply or Auto Battery. Pay attention to the correct polarity**
- 4. Make sure that the amplifier is switched off**
- 5. Adjust the Transceivers RF output power to 5W (6W max) if it is capable of more than 5W output**
- 6. Switch on the Amplifier and start operating**
- 7. Check that the antenna VSWR is acceptable with the amplifier in use. Any large increase in VSWR indicates that the Antenna is not suitable for the power being used. Operation should be halted immediately to avoid damage to the Amplifier / Radio / ATU etc.**

Front / Rear Panel Description

Front Panel



1. AM / SSB Switch
2. Receive Pre-Amplifier ON / OFF Switch
3. Amplifier ON / OFF Switch
4. TX indicator LED
5. Pre Amplifier ON LED
6. Amplifier ON LED
7. Input Attenuator

Rear Panel



1. RTX SO239 RF input connector
2. DC Input power connector. (Polarity is marked on the supplied mating connector)
3. ANT RF Output SO239 Socket to Antenna

Installation:

Unpack the amplifier from its shipping carton and inspect for any signs of damage. The amplifier should be installed (either fixed or mobile installation), in a place that allows good ventilation and provides a suitable base to support it. Failure to allow for reasonable ventilation will cause the amplifier to overheat and damage may occur. A short 50 Ohm patch lead should be used to connect the amplifiers RTX SO239 input connector to the output, (Antenna Socket) of the drive Radio. This length of this cable is not critical but should be of good quality and be kept as short as practically possible. The ANT output connector of the amplifier should then be connected to antenna being used. (If an external SWR/Power meter is to be used the amplifier should be connected to the input and then the antenna to the output, This order of connection is very important. Check also that the Antenna is suitably rated for the power output level. (Antenna SWR should not change much from low to high power). The antenna should be tuned before connecting the power amplifier or with the amplifier switched OFF! .

In SSB mode the front panel switch should be set to SSB. This adds a short delay to the release time of the RTX relays so that pauses in speech do not cause the RTX relay to drop out. In AM or FM mode the SSB delay switch should be set to AM.

The amplifier must be connected via the input power connector to a suitable power supply of the correct voltage output and sufficient current rating. The output should be 13.6 / 13.8V DC but the amplifier may be connected to a supply from 12V to 14V DC without damage. The current rating of the power supply must be at least 40A continuous. Be aware that the current rating must be greater still if the drive radio is also connected to the same power supply, although this is not generally advised.

The voltage output and current rating are very important for low voltage (12V) RF transistors as voltage sag, (poor load regulation) or insufficient current capability can drastically reduce the output power or cause distortion. If full output is not seen then the first thing to check is that the voltage remains above 12.5V at full load. Anything less indicates the power supply is not suitable for the amplifier at full output.

The cross sectional area of the cables used to connect the amplifier to the PSU should not be less than 6mm² or 10 AWG. They should also be kept as short as practicably possible to avoid voltage drop due to ohmic losses. This is less of a problem in a fixed installation where the power supply may be placed close to the amplifier.

For a mobile installation the leads should not exceed a length of 3m and they should be connected directly to the auto battery. An additional fuse may also be connected inline to provide protection in case of cable short circuit to chassis ground from the amplifier to the battery.

The installation location must also provide a suitable ground system both for RF and the AC power supply, (if used). This is very important safety requirement for any radio transmission equipment but as power increases becomes increasingly important. A good RF ground will also help to prevent any returned RF from causing problems with the equipment. Usually erratic operation of equipment when in transmission may be attributed to RF being present or poor RF grounding. Installations where a good RF ground is not possible like operation above the ground floor may require alternative solutions such as artificial earths or the connection of 1/4 wave counterpoises to the operating equipment. Correct RF earthing techniques are however beyond the scope of this manual.

Mobile use should ensure that the ground connections are well bonded to the vehicle chassis ground for best operation.

Operation:

Before using the amplifier the user must be familiar with all of the controls and be sure that it has been connected correctly. Refer to Page 3 of this instruction manual.

Important!!

Before the amplifier is switched on, (switch), the power output of the drive radio should be adjusted correctly if it is capable of outputting a power greater than 6W. This may be done with the amplifier connected but switched off. 6W is the maximum permissible input power to the amplifier, but approximately 4-5W input should be sufficient to realise full output, and an input power of 1-5W is OK as it is not necessary to run the amplifier at full output if not required.

When the amplifier is switched on LED is illuminated.

The amplifier does not have protection against excessive input power and as such the responsibility will be with the user not to overdrive it. Maximum input should not exceed 6W. The best performance of the amplifier will be obtained if the amplifier is operated at just less than full output which should be achieved with about 4-5W input.

If the drive radio cannot be reduced below 6W then the input attenuator should not be used to lower the input to the amplifier. The input attenuator can , and should only be used, to reduce the output of the amplifier if required. There are 6 levels of attenuation.

Damage will occur if the amplifier is operated above 10W input power.

When the amplifier is in transmission LED is illuminated. When it is OFF the amplifier is in receive state.

Antenna Considerations:

The KL503 is designed to work into a 50 ohms resistive load and any antenna outside of this requirement must use an antenna tuning unit between the output of the amplifier and antenna.

It is recommended to check that the antenna to be used is sufficiently rated for at least 500W power handling before connecting this product. It is also recommended to check that the VSWR does not change considerably with increased power as this would indicate that the antenna was not suitable for high power use.

Cable losses particularly increase with increasing frequency. Always use a good quality 50 Ohm feeder and keep the length as short as possible. Not only will this allow more power to reach the antenna but will also increase the signal strength at the receiver.

This amplifier should not be operated into mismatched loads, (high VSWR), An acceptable level should be less than 1.5:1. Less than 2.0:1 is acceptable but some reduction in power may be seen and the amplifier will work less efficiently and generate more heat. There is no protection for excessive VSWR so it is advised that the antenna is tuned correctly for the frequency it is to be used on to avoid damage to the amplifier.

Mode:

The KL503 may be used for all of the common narrow band transmission modes such as SSB, CW, AM, FM, SSTV and data modes etc.

RX Preamplifier:

The KL503 is fitted with an RX preamplifier, that when activated can help to increase the received signal level. This can be used when the signal level is low to help improve intelligibility of the received signal. The RX preamp can be used independently of the amplifier however when the amplifier and preamp are both activated the preamp is automatically switched out of line when the amplifier is in transmission. Switch is used to switch the preamp on and off. LED is illuminated when the preamp is switched on.

Warning: Transmit Time.

Hi Duty cycle modes such as FM and Data modes etc. operate the amplifier at full power all of the time unlike modes like SSB and CW that are either intermittent or only reach peak output for very short times, these high duty cycle modes will run the amplifier much harder and generate more heat in the same amount of time. It should be noted that the amplifier although capable of being used with these modes should not be operated continuously. A transmission time of more than a few minutes should be avoided to avoid excessive transistor junction temperature. The exact time for transmission in these modes will depend on numerous factors such as, how good the ventilation around the amplifier is if there is sufficient space for freely flowing air to circulate, etc. If the ambient temperature is high this will reduce the total time in transmission. Common sense should be exercised, if the heat sink is becoming too hot then sufficient time should be allowed to let it cool down before reuse.

Input drive and power output:

The amplifier should give full output with approximately 4-5W input. Excessive input power should be avoided and the amplifier should always be operated in a responsible manner.

The KL503 features an input attenuator that may be used to reduce the output of the amplifier if the drive radio does not have the facility to reduce its output power. The input attenuator should NOT however be used to reduce the input power level of the drive radio if it is greater than 6W! Otherwise the attenuator may be damaged from overheating. There are 6 levels of input attenuation and position 6 is direct input, with no attenuation. So setting to position 1 will provide the lowest output power from the amplifier, and position 6 the maximum output.

Maximum output power considerations:

All amplifiers have a maximum output and this occurs shortly after gain compression where by Pin no longer produces a proportionate increase in power output. The amplifier should always be operated at a point below its saturated output. Trying to extract every last watt by overdriving the amplifier will not actually help your signal to be stronger, you will in fact cause higher levels of distortion which will make your signal less intelligible at the distant receiver station.

Running the amplifier a little under max output will also allow the amplifier to run cooler and make it more reliable for many years of use.

As an example consider the following situation.

1 'S' point on a receiver is usually approximately calibrated at 6dB so for example the difference between S5 and S7 2 'S' points is 12dB.

The difference between 5W and 250W is about 17dB a big increase to your signal strength, almost 3 'S' points, with the same antenna. Now lets say for example you run the amplifier at a moderate 200W output by slightly reducing the input power, the difference between 250W and 200W is less than 1dB which when you compare this to 6 dB per S point is actually very little and as the amplifier is not running at its absolute maximum will give a cleaner output with less distortion that will actually make a difference at the distant receiver for the better!!

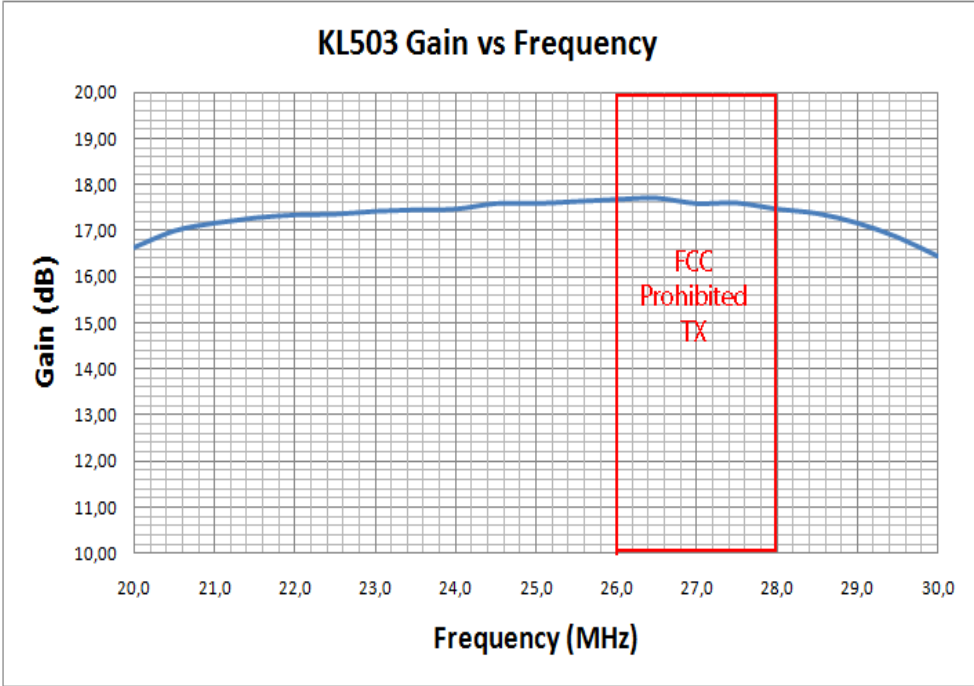

Typical Harmonic Output

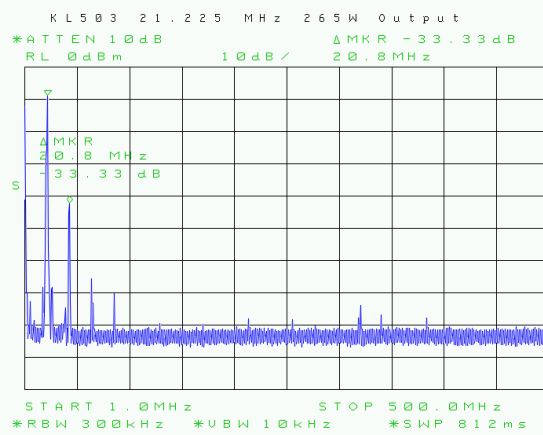
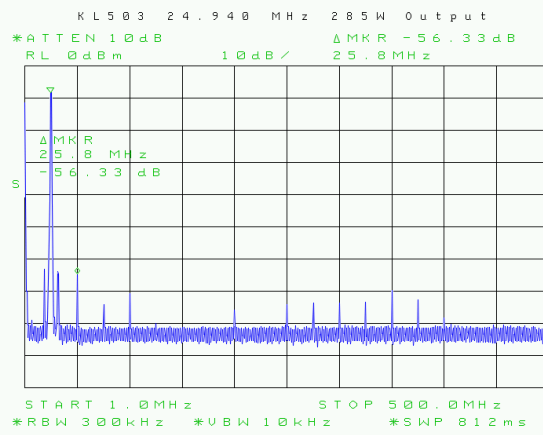
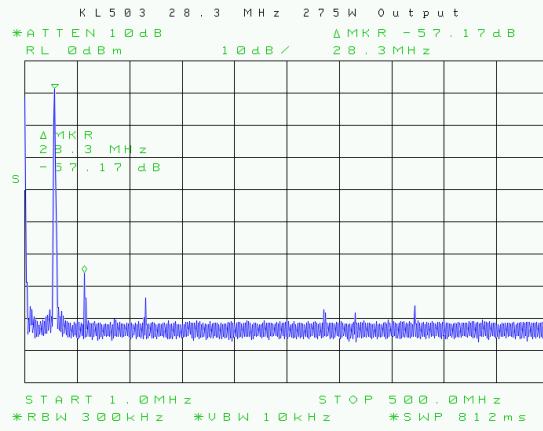

KL503 Schematic

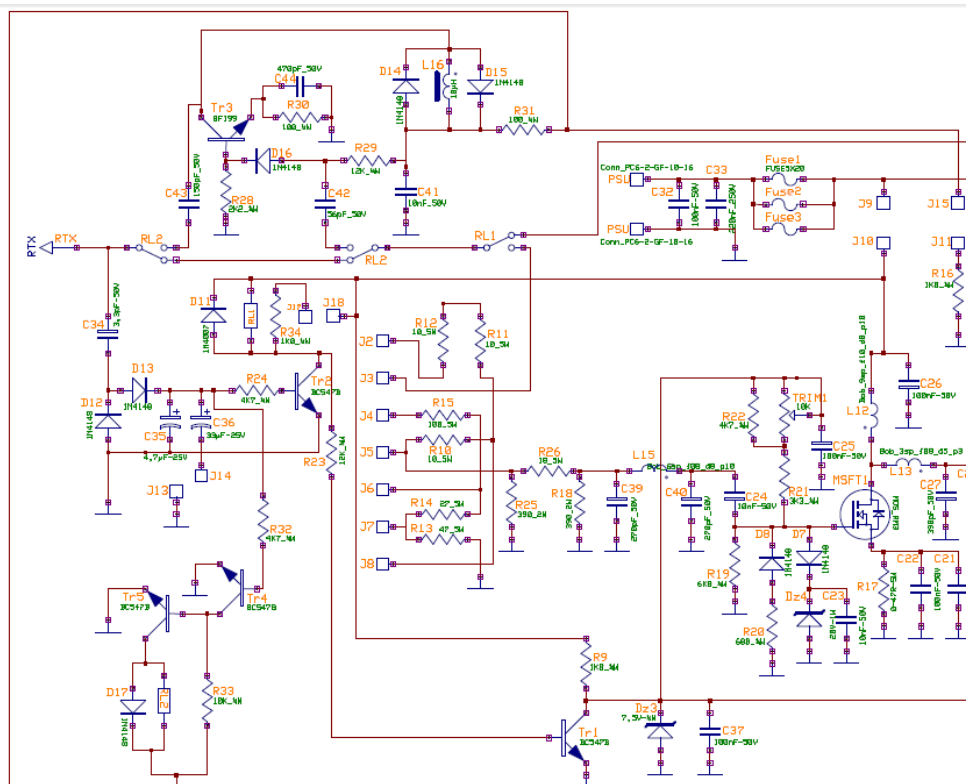

Attention:

The use of Linear Amplifiers are controlled by specific laws within the country of use. These laws must be known to the user and are entirely the responsibility of the user. The manufacturer declines any responsibility from unlawful use.

Warranty:

This product is covered by a 24 month warranty commencing from the date of purchase. The original purchase receipt will be required for any claim. This warranty does not cover aesthetic damage or damage to the RF power transistors from incorrect use.