



RM

Costruzioni Elettroniche

di Marchioni Davide & Daniele s.n.c.

Via IV Novembre 215/5

Casella postale N° 33

40045 Ponte della Venturina (BO) ITALY

Tel +39 0534 60460

Fax +39 0534 60463

E-MAIL ufftec@rmitaly.com

<http://www.rmitaly.com>

Mod. KL 800 linear amplifier

Schematic diagram

Version 1.00

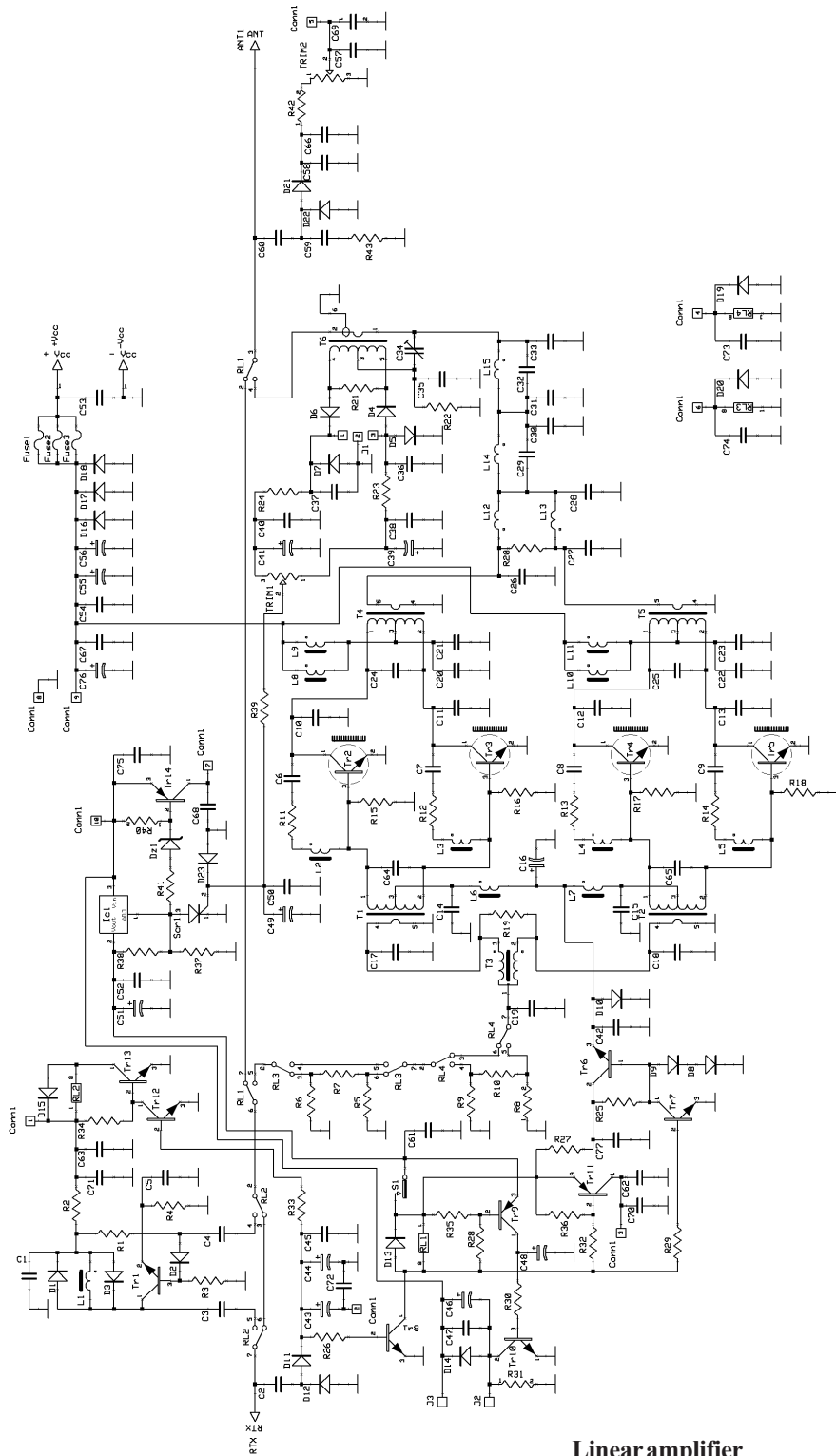

Linear amplifier

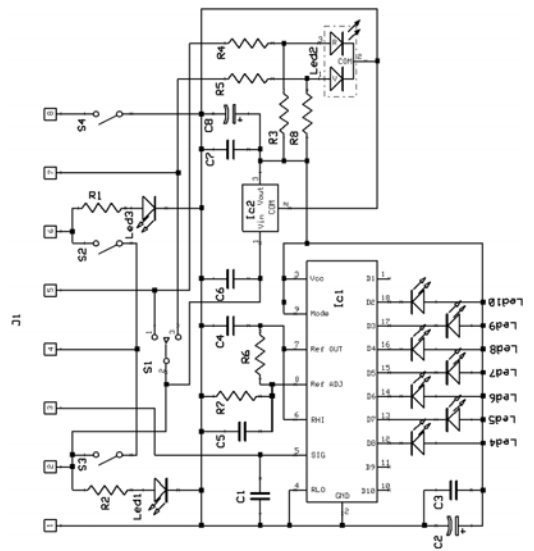

Remote control

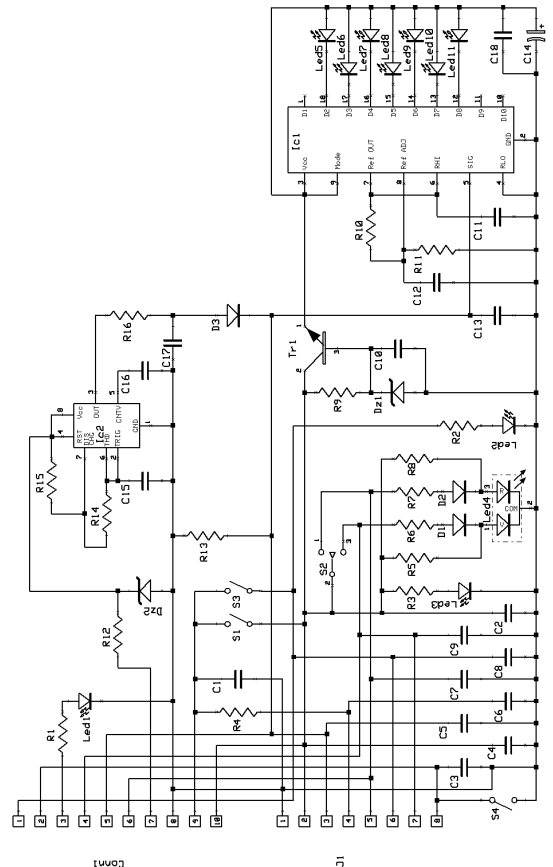

Commandboard



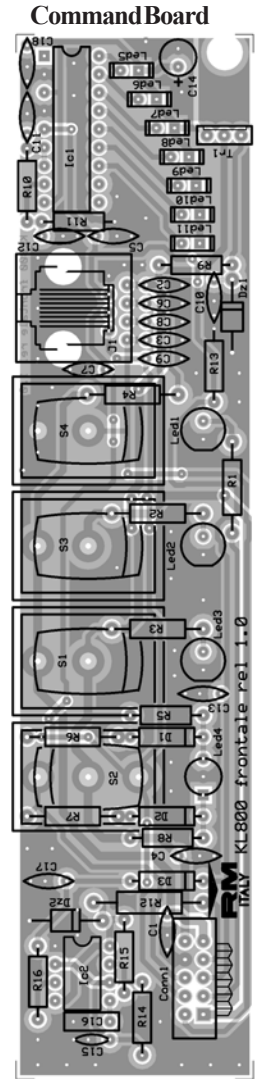
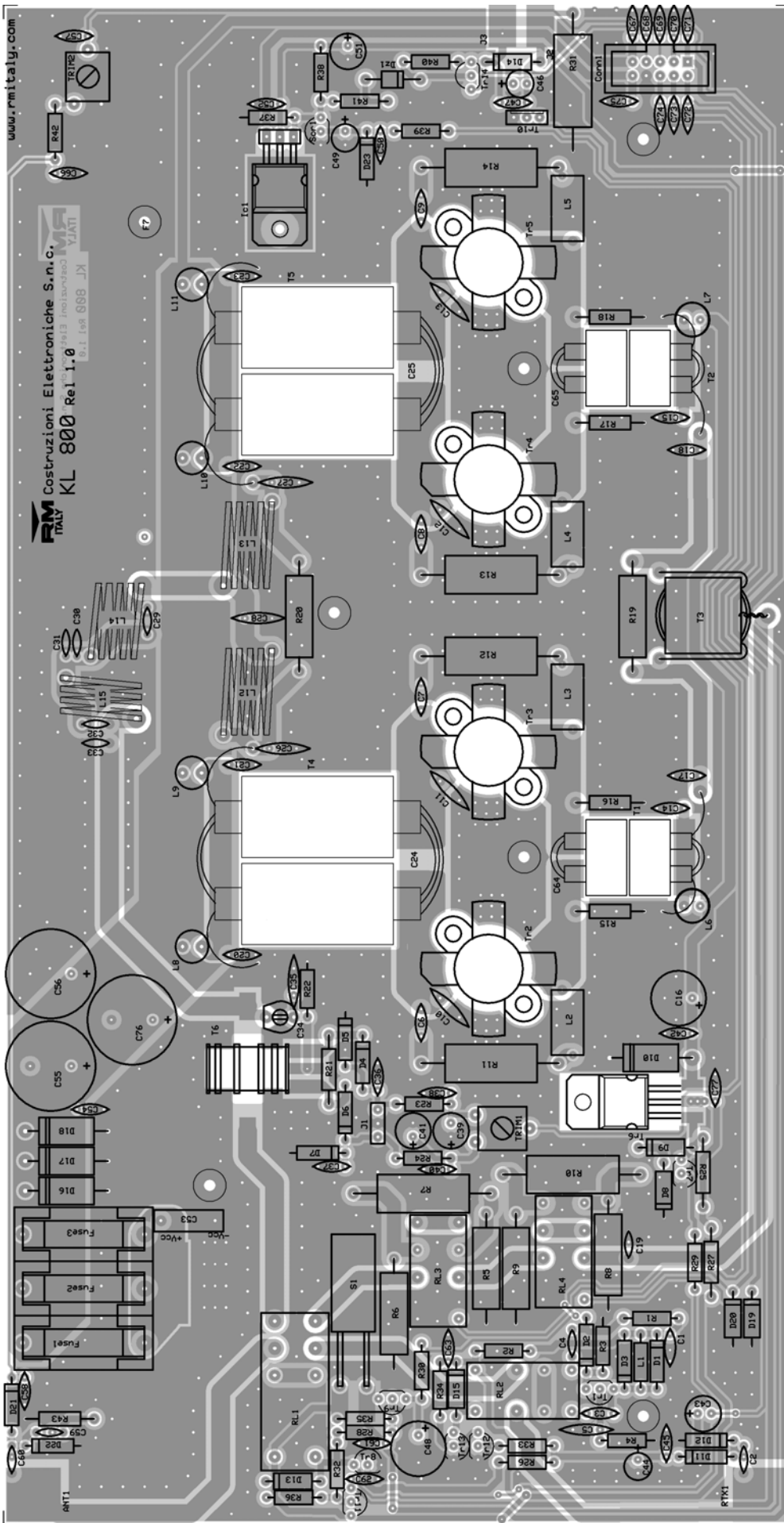

List of components

- C 1 = 10 nF 50 V
- C 2 = 8,2 pF 50 V NP0
- C 3 = 150 pF 50 V NP0
- C 4 = 56 pF 50 V NP0
- C 5 = 470 pF 50 V N750
- da C 6 a C 9 = 47 nF 50 V
- da C 10 a C 13 = 220 pF 500 VN750
- C 14 = 100 nF 50 V
- C 15 = 100 nF 50 V
- C 16 = 470 µF 25 V
- C 17 = 220 pF 50 V NP0
- C 18 = 220 pF 50 V NP0
- C 19 = 27 pF 50 V NP0
- da C 20 a C 23 = 100 nF 50 V
- C 24 = not present
- C 25 = not present
- C 26 = 120 pF 500 V NP0
- C 27 = 120 pF 500 V NP0
- C 28 = 220 pF 500 V N750
- C 29 = 12 pF 500 V NP0
- C 30 = 82 pF 500 V NP0

C ₃₁ = 82 pF	500 V	NP0	R ₂₃ = 10 K Ω	¼W
C ₃₂ = 39 pF	500 V	NP0	R ₂₄ = 1,0 K Ω	¼W
C ₃₃ = 39 pF	500 V	NP0	R ₂₅ = 3,3 K Ω	½W
C ₃₄ = Trimmer 3 - 10 pF (white)			R ₂₆ = 4,7 K Ω	¼W
C ₃₅ = 470 pF	50 V	N750	R ₂₇ = 1,0 Ω	½W
da C ₃₆ a C ₃₈ = 100 nF	50 V		R ₂₈ = 47 K Ω	¼W
C ₃₉ = 33 μ F	25 V		R ₂₉ = 47 K Ω	¼W
C ₄₀ = 100 nF	50 V		R ₃₀ = 4,7 K Ω	¼W
C ₄₁ = 33 μ F	25 V		R ₃₁ = 68 Ω	5W
C ₄₂ = 100 nF	50 V		R ₃₂ = 47 K Ω	¼W
C ₄₃ = 33 μ F	25 V		R ₃₃ = 4,7 K Ω	¼W
C ₄₄ = 4,7 μ F	25 V		R ₃₄ = 22 K Ω	¼W
C ₄₅ = 100 nF	50 V		R ₃₅ = 10 K Ω	¼W
C ₄₆ = 10 μ F	25 V		R ₃₆ = 47 K Ω	¼W
C ₄₇ = 100 nF	50 V		R ₃₇ = 15 K Ω	¼W
C ₄₈ = 1000 μ F	25 V		R ₃₈ = 1,0 K Ω	¼W
C ₄₉ = 10 μ F	25 V		R ₃₉ = 1,0 K Ω	¼W
C ₅₀ = 100 nF	50 V		R ₄₀ = 2,2 K Ω	¼W
C ₅₁ = 100 μ F	35 V		R ₄₁ = 10 K Ω	¼W
C ₅₂ = 100 nF	50 V		R ₄₂ = 10 K Ω	¼W
C ₅₃ = 470 nF	100 V	Polyester	R ₄₃ = 27 Ω	½W
C ₅₄ = 100 nF	50 V		TRIM ₁ = PT10LV 10 K Ω	
C ₅₅ = 2200 μ F	35 V		TRIM ₂ = PT10LV 220 K Ω	
C ₅₆ = 2200 μ F	35 V		da D ₁ a D ₇ = 1N4148	
C ₅₇ = 100 nF	50 V		D ₈ = 1N4007	
C ₅₈ = 100 nF	50 V		D ₉ = 1N4007	
C ₅₉ = 33 pF	50 V	NP0	D ₁₀ = 1N5400	
C ₆₀ = 2,2 pF	50 V	NP0	D ₁₁ = 1N4148	
da C ₆₁ a C ₆₃ = 100 nF	50 V		D ₁₂ = 1N4148	
C ₆₄ = 2 x 470 pF	50V	N750	da D ₁₃ a D ₁₅ = 1N4007	
C ₆₅ = 2 x 470 pF	50V	N750	da D ₁₆ a D ₁₈ = 1N5400	
da C ₆₆ a C ₇₅ = 100 nF	50 V		D ₁₉ = 1N4007	
C ₇₆ = 2200 μ F	35 V		D ₂₀ = 1N4007	
C ₇₇ = 100 nF	50 V		da D ₂₁ a D ₂₃ = 1N4148	
R ₁ = 12 K Ω	¼W		DZ ₁ = 20 V 1,3W	
R ₂ = 1,8 K Ω	¼W		Tr ₁ = BF 199	
R ₃ = 2,2 K Ω	¼W		da Tr ₂ a Tr ₅ = SD 1407	
R ₄ = 100 Ω	¼W		Tr ₆ = BD 241 BFP	
R ₅ = 470 Ω	2W		da Tr ₇ a Tr ₈ = BC 547B	
R ₆ = 470 Ω	2W		Tr ₉ = BC 557B	
R ₇ = 12 Ω	5W		Tr ₁₀ = BD 179	
R ₈ = 220 Ω	2W		Tr ₁₁ = BC 557B	
R ₉ = 220 Ω	2W		Tr ₁₂ = BC 547B	
R ₁₀ = 22 Ω	5W		Tr ₁₃ = BC 547B	
da R ₁₁ a R ₁₄ = 68 Ω	5W		Tr ₁₄ = BC 327-25	
da R ₁₅ a R ₁₈ = 10 Ω	½W		Scr ₁ = P0102	
R ₁₉ = 100 Ω	2W		Ic ₁ = LM 317T	
R ₂₀ = 100 Ω	2W		L ₁ = 10 μ H	
R ₂₁ = 47 Ω	½W		da L ₂ a L ₅ = VK 200	
R ₂₂ = 1,0 K Ω	¼W			

L₆ = VK 200 1 wire
 L₇ = VK 200 1 wire
 da L₈ a L₁₁ = VK 200 2 wires
 L₁₂ = 6 turns on ϕ 14 mm wire ϕ 1,5 mm
 L₁₃ = 6 turns on ϕ 14 mm wire ϕ 1,5 mm
 L₁₄ = 6 turns on ϕ 11 mm wire ϕ 1,5 mm
 L₁₅ = 5 turns on ϕ 11 mm wire ϕ 1,5 mm
 Rl₁ = Relè 24 V 4152.9.024
 Rl₂ = Relè 24 V 3022.9.024
 Rl₃ = Relè 24 V 3022.9.024
 Rl₄ = Relè 24 V 3022.9.024
 Fuse₁ = Fuse₂ = Fuse₃ = 10A 5x20 Fast
 T₁ = T₂ = Input transformer
 T₃ = Input decoupler
 T₄ = T₅ = Output transformer
 T₆ = ANRA 700/12
 S₁ = 80 °C Thermostat
 Conn₁ = To Command Board
 J₁ = Service connector
 J₂ = J₃ = to Fan

Commnd Board

C₁ = 10 nF 50 V
 C₂ = 100 nF 50 V
 C₃ = 100 nF 50 V
 C₄ = 10 nF 50 V
 C₅ = 10 nF 50 V
 C₆ = 100 nF 50 V
 C₇ = 100 nF 50 V
 C₈ = 100 nF 50 V
 C₉ = 100 nF 50 V
 C₁₀ = 10 nF 50 V
 C₁₁ = 10 nF 50 V
 C₁₂ = 10 nF 50 V
 C₁₃ = 10 nF 50 V
 C₁₄ = 22 μ F 25 V
 C₁₅ = 1.0 μ F 50 V Multilayer
 C₁₆ = 10 nF 50 V
 C₁₇ = 10 nF 50 V
 C₁₈ = 10 nF 50 V
 R₁ = 2,2 K Ω ½W
 R₂ = 2,2 K Ω ½W
 R₃ = 2,2 K Ω ½W
 R₄ = 1,0 Ω ½W
 R₅ = 12 K Ω ¼W
 R₆ = 2,2 K Ω ½W
 R₇ = 2,2 K Ω ½W
 R₈ = 15 K Ω ¼W

R₉ = 1,0 K Ω ¼W
 R₁₀ = 1,0 K Ω ¼W
 R₁₁ = 8,2 K Ω ¼W
 R₁₂ = 470 Ω 1W
 R₁₃ = 4,7 K Ω ¼W
 R₁₄ = 470 K Ω ¼W
 R₁₅ = 1,0 M Ω ¼W
 R₁₆ = 4,7 K Ω ¼W
 D₁ = 1N4148
 D₂ = 1N4148
 D₃ = 1N4148
 Led₁ = TX (red)
 Led₂ = Pre ON (yellow)
 Led₃ = Lin ON (green)
 Led₄ = Input Power (bi-color)
 da Led₅ a Led₁₁ = Watt (green)
 Dz₁ = 15 V 1,3W
 Dz₂ = 15 V 1,3W
 Tr₁ = BD 179
 Ic₁ = LM 3915
 Ic₂ = NE555
 Conn₁ = To amplifier board
 J₁ = To remote command
 S₁ = Lin ON
 S₂ = Input power
 S₃ = Pre ON
 S₄ = SSB

Remote Control

C₁ = 10 nF 50 V
 C₂ = 22 μ F 25 V
 C₃ = 10 nF 50 V
 C₄ = 10 nF 50 V
 C₅ = 10 nF 50 V
 C₆ = 100 nF 50 V
 C₇ = 100 nF 50 V
 C₈ = 10 μ F 25 V
 R₁ = 2,2 K Ω ½W
 R₂ = 2,2 K Ω ½W
 R₃ = 8,2 K Ω ¼W
 R₄ = 2,2 K Ω ½W
 R₅ = 2,2 K Ω ½W
 R₆ = 1,0 K Ω ¼W
 R₇ = 8,2 K Ω ¼W
 R₈ = 10 K Ω ¼W
 Ic₁ = LM 3915
 Ic₂ = LM 7812
 Led and S = same to command board