

GO MOBILE AT 500 WATTS

SGC Significant Products



SGC

SGC – The SSB People

SGC develops, manufactures, and sells high performance single sideband (SSB) communications equipment. For more than 25 years, the company has sold to the marine, military, aviation, and industrial markets world wide. Over these years, SGC has earned an outstanding reputation for product reliability and for service after sale.

On the cutting edge of technology, the company keeps pace with equipment options, engineering developments, and design requirements. Its products are the most competitive in the entire long distance communication market. SGC equipment is presently being used by the United Nations and international relief agencies for inter-communications in developing countries throughout the world. Many competitive racing vessels, as well as fishing boats, tugs, and commercial craft are equipped with SGC equipment. In fact, an SGC radiotelephone provided the only communication available on a recent Polar expedition by the National Geographic Society.

SGC supplies U.S. Government agencies, foreign governmental agencies, and major petroleum companies throughout Asia and Latin America. In addition, SGC supplies equipment to major international geophysical corporations and exploration crews.

All SGC equipment is designed and manufactured in the USA, with some components imported from different international suppliers and manufacturers. SGC has qualified people ready to provide technical information, assistance in selecting equipment, and recommendations for installation.

SGC welcomes your call to discuss your HF-SSB requirements.

Go Mobile at 500 Watts

Facts and Equipment

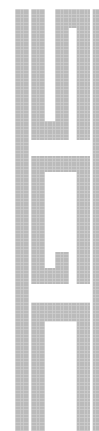
Another
Informative Publication of
SGC, Inc.
Manufacturer of Advanced
Technology

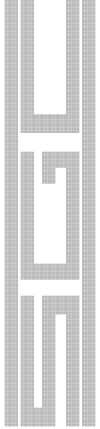
The logo for SGC, Inc. features the letters 'S', 'G', and 'C' in a bold, stylized, blocky font. Each letter is composed of multiple parallel horizontal lines, creating a sense of depth and a modern, industrial aesthetic.

“No Compromise Communications”

Table of Contents

Introduction	1
Chapter 1 Changes in Mobile Radio	2
Chapter 2 Orienting Yourself to 500 Watts	4
Engine Compartment	5
Driver's Compartment	5
Exterior	6
Rear Compartment	10
Chapter 3 DC Power Supply System	
for a Mobile Installation	11
Measuring your Vehicle's Requirements	11
Testing your Electrical System	12
Isolating the Auxiliary Battery	13
Evaluating Batteries	15
Chapter 4 Antennas and Grounds	17
Antenna for HF Mobile Installations	17
Mobile Grounds	20
Chapter 5 Noise Suppression and	
Shock-Mounting	24
Noise Sources	24
Solutions for Electrical Noise	25
Shock and Vibration Mounting	26
Chapter 6 Installation Procedures	28
Engine Compartment	28
Driver's Compartment	31
Exterior	38
Rear Compartment	52





Chapter 7 Installation Variables	55
Geo Metro	55
Cadillac	58
Jeep Cherokee	60
Geo Tracker	62
Non-SGC Transceivers	65
Chapter 8 Going Mobile at 150 Watts	68
Auxiliary Battery	68
Information Applies	69
Appendix A — QMS System	A-1
Appendix B — Selection of Equipment	B-1
Appendix C — Test Data	C-1

Introduction

Going Mobile in HF is both art and a science. Like any other art or science, the achievement comes after years of vocation, experience, knowledge, research, discipline, and passion.

At SGC, we have dedicated more than 25 years with passion—and at times with frustration—to find a way for everyone to succeed in “going mobile.”

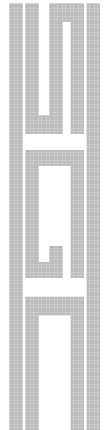
Each new mobile installation that has been performed around the world—from Zambia to remote parts of Alaska—has first performed here at our headquarters in Bellevue, Washington. From sleek Mercedes limousines to desert jeeps, we have configured a quick mount system (our QMS) that allows easy, efficient, and reliable performance—on the first try.

The design of the QMS allows fast and easy installation, efficiency, and performance. Our goal has been to eliminate the frustration and add the excitement of “going mobile” for any installer, practically without experience. This now has been helped with the publication of our book, *Go Mobile at 500 watts*.

I cannot thank enough our marketing, technical, and engineering staff in making this book available to make mobile communications easy.

So, Go Mobile with SGC.

Pierre Goral
President



Changes in Mobile Radio

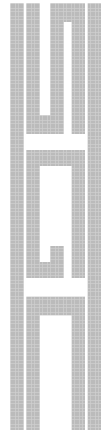
In the early days of radio, mobile radio also had its humble beginnings. The first mobile radio systems, aboard passenger-carrying ships, used low and medium frequencies, and the mode was CW (“continuous wave” using Morse code). Special shore stations installed to handle ship traffic quickly became an important safety feature, the obvious benefit being the safety of passengers.

The first land mobile systems were able only to receive. Around 1920 some police agencies had dispatch systems that operated around 1600 kilohertz. These early systems were bulky, heavy, and not very efficient by today’s standards, but the many benefits of mobile communications helped to accelerate the radio art.

As a result, today’s systems permit flexible communications almost anywhere, with installations in just about anything that moves—automobiles, trucks, even sub-compacts. High frequency mobile radio, made more effective with the introduction of SGC’s external coupler mount (the QMS system), allows long distance communication for commercial, industrial, military, and scientific organizations as well as the Amateur Radio Operator— without the need for the expensive repeater systems required for VHF and UHF communications.

This book will guide you through the installation of your SGC 500-watt mobile system. It also contains information, techniques, and procedures that apply to radio gear from other manufacturers:

- Chapter 2 helps you to see your vehicle as a site for a 500-watt mobile installation.



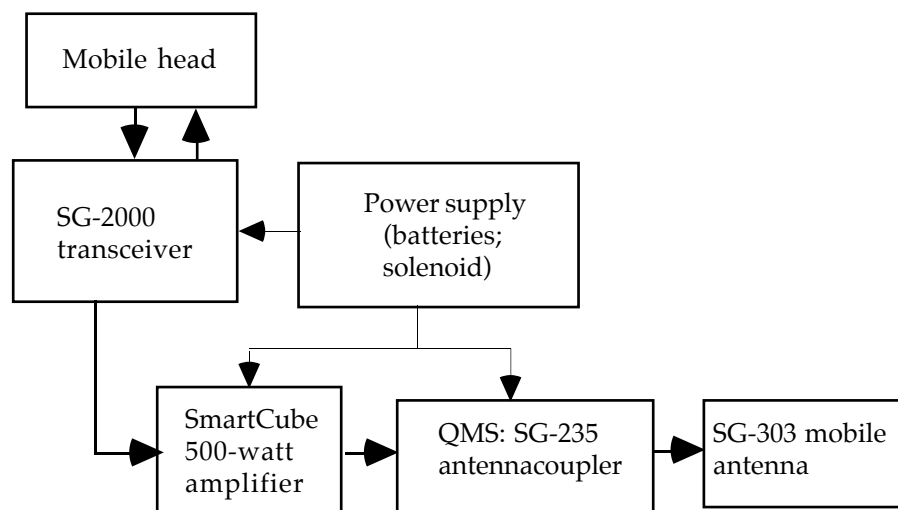
- Chapter 3 on D.C. power gives important power supply information to ensure maximum equipment performance.
- Chapter 4 on antennas and grounds enables you to optimize your installation, including critical information on proper grounding techniques and procedures for maximum system performance.
- Chapter 5 provides pointers on noise and vibration that could affect your installation.
- Chapter 6 on equipment mounting gives general as well as specific information on planning, installing, and securing your radio system.
- Chapter 7 provides installation tips for installing the SGC 500-watt system in a representative range of automobiles: Chevrolet's GEO Metro, Jeep's Cherokee, and Chevrolet's GEO Tracker, and a Cadillac model. It includes installation tips on other manufacturers' radios in our mobile 500-watt installations.
- Chapter 8 discusses the alternative 150 watt mobile installation.

This book supplements the documentation provided with SGC equipment and refers to those manuals as needed. Ensure that you have them close at hand. Please review this entire book before starting your installation.

Orienting Yourself to 500 watts in Your Vehicle

After purchasing your SGC 500-watt mobile system, you will undoubtedly be anxious to install it as quickly as possible and begin operation.

However, we recommend that you first spend some time in reviewing the design and layout of your vehicle, then in planning a logical installation scheme. The planning time you spend beforehand could save you hours of reinstallation time later.



**Figure 1 — The components of the
500-watt mobile system**

This book will assist you in planning and installing your system

- by covering important aspects of mobile installations, and
- by identifying some common difficulties you may encounter. Installations will vary slightly between one vehicle and another, but these principles should apply to all.

Engine Compartment

Open the hood and take a close look at the engine and electrical system layout. (We discuss noise suppression from such elements as spark plugs and the ignition coil in Chapter 5.)

Firewall openings. Look at the several penetrations of the firewall where wires and hoses pass through. These locations will become important later as you route the cable from the auxiliary battery to the main battery terminals.

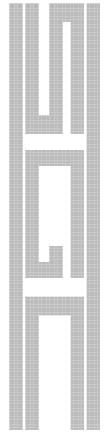
Mounting points. Look for “secure” mounting points which offer structural integrity—like flat sheet metal areas or brackets that could be used to support the solenoid.

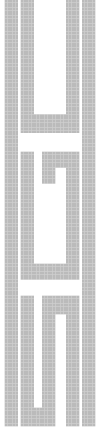
The engine compartments of many cars are quite small, and crammed full of components. They also employ unibody construction. Because the body is formed into curves and bends to accommodate suspension and drive train components, finding a flat location may be difficult, but don't give up right away. Many mounting possibilities are not immediately obvious. Try to locate the solenoid as far as possible away from the ignition coil to reduce noise pickup.

Driver's Compartment

Cable runs. Plan to route your cable runs beneath interior moldings or carpeting, if possible. Running beneath moldings keeps cables out of sight and protects them from pulling and kicking when people enter or exit the vehicle.

Fasteners and moldings. Newer automobiles make widespread use of polymer-based moldings and fixtures. These installations use various kinds of fasteners and locking mechanisms to hold them in place—unlike older (and sometimes more straight-forward) screw-fasteners.





Removing a panel: If you are unsure how to remove a molding or panel, don't use force or try prying it with an improper tool. You may mar the surface of the plastic or damage the fasteners, some of which use small locking tabs or clips cast into the panels. Special tools are available to remove panels without damage.

Driving safety. Keep driving safety in mind: ensure that the transceiver, control head, amplifier, and antenna coupler do not block your field of vision (front, side, or rear), do not block your ability to see through side-view and rear-view mirrors, and do not interfere with the operation of gearshift or pedals.

Locating the control head: The PowerTalk control head is your "command and control" link to the SG-2000 transceiver. Its large high-visibility frequency display and rugged spinner tuning knob makes operation in a mobile environment safe and easy.

There are many locations possible for mobile operation: below the dash, on the dash, above the dash, and overhead. Choose a safe location that will neither interfere with your view of the road nor hamper vehicle operation.

Mounting the control head: The control head can be installed either on a mounting bracket or on an adjustable suction-cup mounting arm for dashboard or window surfaces. (SGC Catalog No. 04-25)

Exterior

The QMS antenna/coupler configuration features a unique strap-mounting system. No other manufacturer presently offers a system utilizing this approach. The QMS system affords three important aspects that concern avid mobile operators/car owners:

- Efficient, all-band, high-power performance using a proven antenna design with both electrical and mechanical integrity under the most adverse driving conditions.
- Easy transportability from one vehicle to the next. The QMS mounting system can be considered “semi-permanent” because its suction cups and strapping allow removing the entire unit from one vehicle for immediate installation on another. The QMS goes in place, and stays in place, until you need to move it.
- Non-intrusive mounting design. The QMS system allows you to enjoy mobile operation without depreciating your vehicle’s value with unsightly holes, with scrapes and scuffs from magnetic or other mounting techniques. Drilling body panel holes in a \$20,000 vehicle to accommodate a \$20 fitting is not something even the most avid mobile operator would accept.

Mounting ledges for QMS straps and hooks. Suction cups form one half of the QMS anchoring system; nylon straps finish the job. Included with your QMS system are several plastic-coated steel hooks. The nylon straps loop through these, and the hooks hold onto ledges to form a secure anchor point from which to tighten the strap tension.

On most compact vehicles (especially ones with hatchbacks), mount the QMS unit on the left rear side window. Each of four straps will tie to the front door frame, to the hatchback, to the wheel well (fender), and either to the roof or to the lower body edge.

For this installation, find body panel edges or “lips” on which the steel hooks will catch and anchor. With a little bit of exploration and ingenuity on your part, you can find the edges needed to secure the hooks and mounting straps.

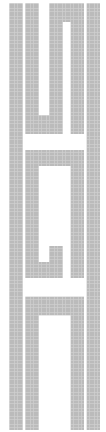




Figure 2 — Hooks can attach beneath door gaskets

Look under rubber gaskets: Try lifting up the rubber sealing gasket that goes around the rear hatch and door openings. Underneath you will find a “knife-edge” strip of metal: the hooks often mate well there. In most cases the rubber stripping can slip back over the knife edge without affecting door/hatch closing or proper sealing. The steel hooks are flexible enough that they can be slightly bent or shaped to the proper angle to allow a custom fit on the door/body edge of your vehicle. Use a vise-grip and a large pair of pliers to do this. Try to get the angle right the first time because repeated bending will stress-weaken the steel.

Straps are abrasion-resistant: The prospect of having a door or hatch close over the QMS mounting straps may bother you at first, but please realize that they are abrasion resistant, and two straps have a combined thickness of only about 4 mm, while they retain a tensile strength of over 1000 pounds.

Body openings for cable lead-through. Several leads must go from the SG-235 coupler (inside the QMS) through the vehicle body to connect to the SG-500 PowerCube, SG-2000 Transceiver, and vehicle ground (chassis). Within one

sheath run a multi-conductor cable, the RF coax lead (within one sheath), and a braided strap for RF grounding.

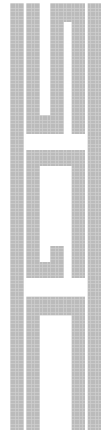
Pre-existing holes: Notice some pre-existing holes may be present in the vehicle body. They are used for ventilation or for wiring lead-throughs from options that may or may not be available on your vehicle. Try to utilize these first, instead of drilling any holes in your car.

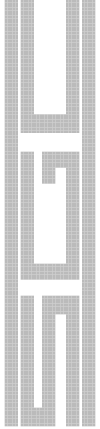
Inconspicuous holes: Another idea is to locate a door “knife-edge” or lip and file a “slot” just wide enough for a cable to pass through. In many instances the rubber sealing strip can be reinstalled to cover the cable.

Grounding strap. The importance of the braided RF grounding strap cannot be over-emphasized—a good electrical and mechanical connection to the vehicle chassis must be found. (See Chapter 4 for detailed treatment of mobile grounds.)

The cable is flat and flexible enough to feed through most door/hatch edges without affecting door closure. Slip a long sleeve of heat-shrink tubing onto the braid along the length that will be directly exposed to the air and door sealing surfaces (8 to 10 inches should suffice). Try to ground the braided cable to the chassis using existing bolts and screws, when possible. Prepare the area where the braided surface will contact by sanding away the paint and primer until shiny, bare metal appears.

A part in the braid large enough to pass a screw or bolt can be made by simply pushing strands apart with a small pointed object (such as a ball-point pen) to accommodate the fastener. Remember to re-tighten any bolts or screws firmly





Rear Compartment

Depending on the size of your rear compartment, plan the placement of your transceiver, amplifier, and battery so that you retain access to your spare tire and your tools.

Constructing a plywood platform (see discussion of rear compartment in Chapter 6) which could mount on spacers or rubber feet can hold equipment securely and still give spare tire access.

DC Power Supply System for a Mobile Installation

Because your vehicle's electrical system has a limited capacity, it is important to understand the power requirements of your mobile radio installation. Inadequate power to the system can render the best radio equipment useless.

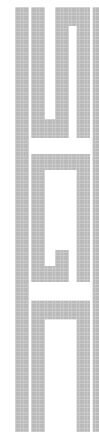
Let's first take a look at the battery and charging system on a later model vehicle. Typical systems have a lead acid battery that, of course, is used to start the engine and that takes up the electrical slack at low engine speeds when the alternator may not provide enough power to operate the electrical accessories.

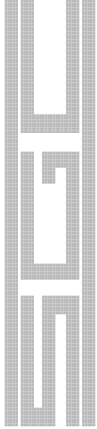
Measuring Your Vehicle's Requirements

Your vehicle's accessories typically draw this much DC current:

Headlight system	15 amps
Heater fan	7 amps
Windshield Wiper	6 amps
Air Conditioner	15 amps or more
Electric defroster	10 amps or more
Radio-Stereo	5 amps
Starting motor	200 amps or more

As you can see, the maximum likely wintertime current draw in normal vehicle operation is around 45 to 55 amps. The exception is the starter motor, which draws very high current but for only short periods. Today's alternators can easily provide this much current, and often much more. (Alternator capacity is usually indicated on a plate attached to the alternator itself.)





Our Geo Tracker and Metro installations both have 55 amp alternators. Such typical 55-amp alternators leave about 10 amps in reserve. Automobiles with accessories like air conditioning, power windows, and power seats, may have alternator capacity up to 100 amps.

Current requirements. Our 500-watt system has these current requirements:

SG-2000 Transceiver	16 A (transmit)
	0.8A (receive)
500 W Power Cube	40 A average (SSB)
	90 A peak
SG-235 Coupler	0.9 A

Fifty-seven to 107 amps is a lot of current. But don't worry; these high current demands occur only during transmitting. Just as the starting motor needs high current for only short periods, the transmitter system can get enough power from the battery system, which takes up the slack between peak demands and average demands for power. The duty cycle for typical radio operation is much less than 50%. That is, we listen a lot and transmit relatively little.

Current at idle: Full charging output is not available when the engine is idling. If you must operate "mobile at rest," consider making some temporary provision to increase your engine idle speed.

Testing Your Electrical System

Before you begin your installation, we recommend that you perform at least a cursory test of your charging system. For this you will need a DC volt meter. First, run the vehicle long enough for the engine to reach normal operating temperature. Then, provide a load for the alternator.

- Do this by turning on some of your vehicle's accessories. Running the air conditioner (or heater fan on high) as

well as the headlights will demand about 25 to 30 amps from your alternator.

- Next, bring the engine speed up just above normal idle—about 1200 RPM.
- Allow a minute for the system to stabilize; then measure the voltage across the poles of the vehicle battery. You should see at least 13.6 V. Many charging systems will operate at a higher voltage but should not exceed 14.6 V.

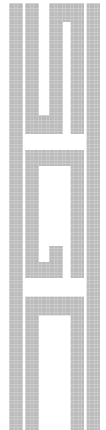
If your system falls within this range, it is probably functioning well. If not, it will need further diagnosis and repair. Note that one of the most common reasons for a low output from the charging system is a worn or improperly tensioned alternator drive belt.

If your charging system is functioning, and you are a typical radio user, you will be able to operate the 500-watt system without any modification to the charging system. In special instances, where the transmitter operates for extended key-down periods, it may be necessary to install a special, high capacity alternator. (Remember that the current requirements for an SG-2000 driving the SG-500 can exceed 100 amps—four times that required to run automobile accessories. At 10.0 VDC, the amplifier will drop off-line due to undervoltage. The auxiliary battery maintains the required current needed to power the 500 watt system.)

Isolating the Auxiliary Battery

Our suggested installation of the 500 Watt system and additional auxiliary battery, along with a “smart” solenoid, will not only insure enough power for a whopping signal from your radio system but will provide for a “jump start” capability just in case your main battery becomes discharged.

The solenoid requires connections only to the main battery, auxiliary battery, starter switch, and ground. It will work



well on any conventional 12V automotive system.

Figure 3— The "smart" solenoid isolates the batteries



“Smart” solenoid features. The “smart” solenoid offers fully automatic switching of the auxiliary battery system. It also protects the charging system from damage resulting from excessive current due to high discharge rate.

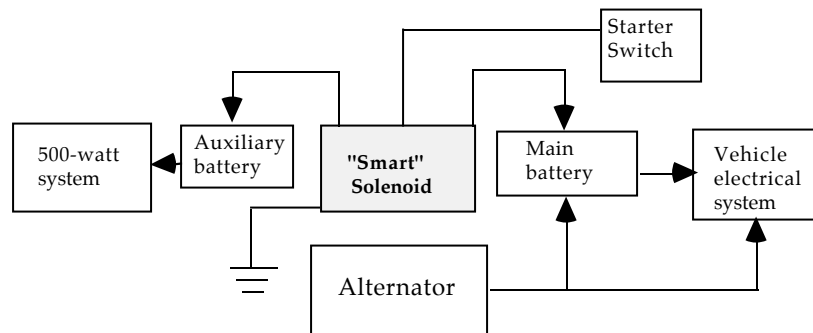
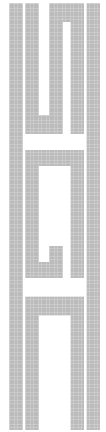


Figure 4 — Flow chart of 500-watt system showing solenoid and auxiliary battery

How it works. The smart solenoid monitors the charging system voltage. When the charging system is not operating (engine off and system voltage below 12.8V), the solenoid opens.

Charging: When the charging system is operating (engine on), the solenoid will connect the main battery and the auxiliary battery, allowing the auxiliary battery to charge. The solenoid engages at about 12.8V.



“Jump start”: The solenoid will connect the batteries when the main battery voltage is more than 1 V below the auxiliary battery voltage and the starter switch is closed. This is the “jump start” mode. (An optional remote light could be installed to monitor this condition.)

System protection: The Smart Solenoid protects the charging system by opening the circuit between the main and auxiliary batteries if the charging system voltage drops below 12.8V even when the engine is running.

Benefits

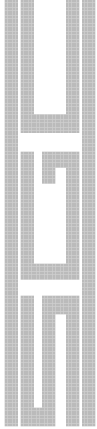
This system offers several benefits. Probably the most important is that the auxiliary battery can be located adjacent to the 500-watt system, saving much labor and expense in the power cabling necessary to provide the high current demanded by the radio system. Additionally, this method provides a fully charged backup battery in the event that either one of the batteries is accidentally discharged.

As you can see by Figure 4, the solenoid connects the main and auxiliary batteries together to provide a “jump start” feature.

Difference from previous SGC publications. SGC addressed the mobile power supply in a different and less effective way in the SG-500 SmartPowerCube manual (Sect. 7.3 and 7.4) We now recommend the solenoid installation described above.

Evaluating Batteries

Lead acid battery. The lead acid battery in your vehicle is specifically designed to provide to the starting motor high



current for short periods of time. The service life of a standard automotive battery may be shortened considerably by continuous deep discharge and recharge cycles. This type of battery will work as an auxiliary battery to power your radio system but is less than ideal.

Deep cycle battery. We recommend that you use either a deep cycle marine/RV battery or a Gel Cell designed for this purpose. Gel Cells are similar to conventional lead acid batteries, except that the electrolyte is in a jelled state. Whereas liquid electrolyte batteries must remain upright, some gel cells may be mounted in any position.

Explosive gas. Gas escaping from batteries may be explosive. Keep flame and sparks away. Because battery electrolyte is chemically active (sulfuric acid), it is necessary to keep the battery clean. Electrolyte collected on battery posts can be neutralized with baking soda, but do not allow this to enter the battery.

Caution: Always wear eye protection and rubber gloves when working with batteries. Make sure that you read the battery manufacturer's instructions and warnings.

Antennas and Grounds

Antennas for HF Mobile Installations

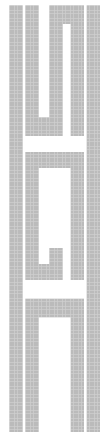
An antenna does not have to be a physical quarter wavelength in order to work efficiently: shortened antennas can be used. But when an antenna is less than a physical quarter wavelength, it has less efficiency than a larger antenna. Use of a high performance antenna coupler, such as the SG-235, will improve antenna performance dramatically.

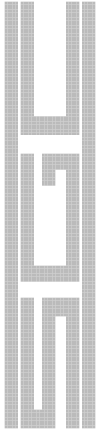
Short antennas represent some compromise. However, they can give good performance, especially in applications such as mobile HF work.

The standard whip antenna used in the HF environment has a brief but interesting history related to the Citizen's Band radio craze, which swept the United States in the 1970's. The "generic" 108 inch long stainless steel whip, while it could be mounted in such a way as to operate at 27 MHz without any coils, traps, or matching network, is not generally well built and may fail when used in commercial service because of its poor base insulation and its lack of a shock-absorbing base: it whips around.

Single frequency antennas. Single element commercial heavy duty antennas such as those made by Hustler are a step in the right direction for lower frequency HF work. Although some companies still sell 108" stainless steel whip-based products, the professional HF person will always choose a center or top loaded whip antenna if a single frequency is to be used.

Multiple frequency antennas. When a series of frequencies across the spectrum is to be used, the professional answer is either to put up with changing loading coils or to put in a continuously loaded helically-wound antenna. This





provides a reasonable load to a good antenna coupler at all frequencies from about 1.8 to 30 MHz.

SGC whip with SG-235 coupler. SGC is the only manufacturer to add the good attributes of a 108" whip (which performs well at the 20 MHz range and above) with the high performance of a helical antenna that performs well at the lower frequencies.

The use of an antenna coupler is required on all but the most carefully matched center- and top-loaded mobile whip antennas which present close to a 50 ohm match to the antenna lead.

Although it is tempting to use both a coupler and a center-loaded antenna, the center loading element of a loaded antenna already acts as an RF choke at high frequencies. Thus, it actually reduces the effective length of an antenna if used on a high band.

That is why for 500-watt mobile installation, SGC recommends its SG-303 whip antenna, SG-235 antenna coupler, and the Quick Mount System.

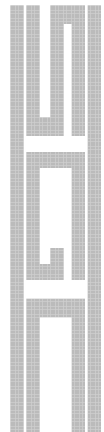
QMS for Mobile Use. The QMS-3-500 antenna system, comprising the SG-235 Coupler mounted in a QMS and driving the SG-303 high performance whip antenna will typically yield substantial improvement in performance over a conventional 1.8 to 30 MHz HF mobile antenna installation. When we start making claims of 20 dB, a lot of people (maybe even you)

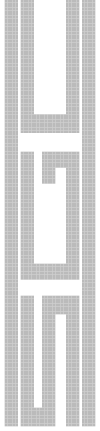


Figure 5 — The QMS attaches securely to the GEO Metro

will be skeptical. So let us show you how you can get a significant increase in gain by simply using a QMS-3-500 compared with any other 3.5 to 30 MHz system:

- Most antennas are so heavy that they are mounted on the bumper of a vehicle. Because of this location, about a third of the antenna *is less than a foot from the grounded body sheet metal*. This is equivalent to a capacitor of 25 to 100 pico Farads shorting your antenna. QMS, mounted high on the side of the vehicle, gains 3 to 6 dB.
- Body sheet metal prevents the antenna from radiating evenly. It shields the signal in certain directions and causes *distorted radiation lobes*. QMS gains another 3 to 6 dB.
- An antenna coupler mounted in the trunk of a vehicle will have 1 to 2 feet of HV cable going to the antenna on the outside. A lead wire as short as 1-foot, with a 9-foot antenna, means that fully *10% of the antenna system is inside the vehicle* where it will neither transmit nor receive. It also creates another 10 to 100 pico Farads of capacitance which results in more losses. With QMS, you'll pick up 3 to 6 dB.
- Wire size of the antenna counts. Most resonant type antennas are wound with number 22 wire. The SG-303, the antenna used with the QMS, is wound with 3 millimeter wide tape wire strap—equivalent to AWG #4 wire. With a 100-watt transceiver, you'll develop 3 to 7 amps (or more) of RF on the antenna, and *7 amps through #22 wire represents major losses*. The QMS with the SG-303 antenna scores another 3 to 6 dB advantage.
- The SG-303 is actually *two antennas in a single casing*. A single rod equivalent to the conventional stainless steel whip element resonates at about 22 MHz; in addi-





tion, a helically wound element resonates at about 10 MHz. This means that on lower frequencies, those under 20 MHz or so, the SG-303 will vastly outperform a conventional 9-foot whip.

- Some hams use the “antenna tuner” built into some radios, feeding their antennas directly with coax. But in a non-resonant antenna, a very high SWR exists on the feed-line between the radio and antenna even if you get a low SWR reading with a built in tuner. When your feed-line SWR is above 4 to 1, you have effectively put 29 pico Farads per foot capacitance to ground. Whereas built-in tuners are merely trimmers, the QMS system-puts a true coupler right at the antenna, adding at least 3 to 6 dB more gain for QMS.

No holes in mounting. QMS mounts without drilling any holes in your vehicle, a major advantage at vehicle trade-in time. (See Chapter 6 and Appendix A for installing the QMS system.)

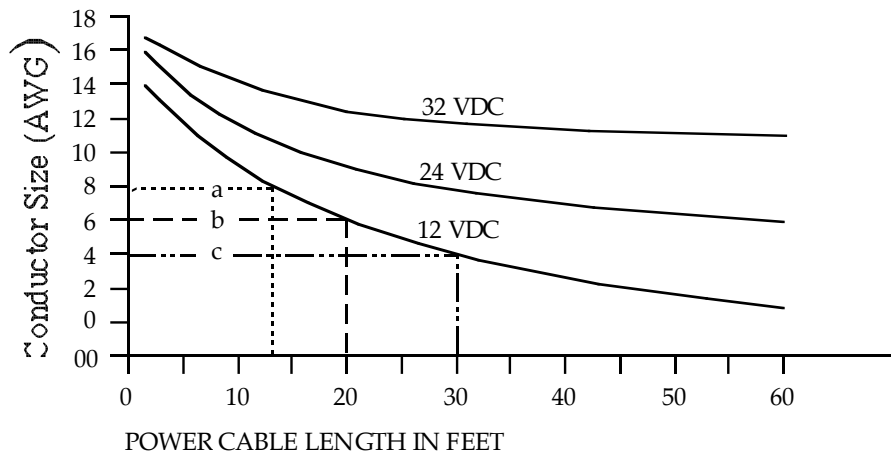
Mobile Grounds

“They don’t build ‘em like they used to” is certainly true about today’s automobiles. Not only do they have more wires—which can pick up stray RF—but they generally have fewer welds—which means the ground system presented by the vehicle may not have high integrity. As a result of a smaller ground system, ground loops may occur, and in some situations, reduced radiation efficiency.

Here are some guidelines that will eliminate some ground issues:

Wire runs. Keep all wire runs as short and direct as possible. This means keeping the path direct. It is especially important to keep the antenna wire from the SG-235 coupler as short as possible to the external mobile antenna (we recommend the SG-303).

Wire size. Use the largest wire size practical for power wiring. We recommend power lines from the battery to the radio of at least #6 gauge stranded wire and that the ground of the battery be cleaned periodically to make as good a connection as possible. Long wire runs will cause loss. We recommend no 12 VDC run of more than 25 feet.



Examples:
a — 100W SSB gauge 8 for 12V operation
b — 150 W SSB gauge 6 for 12V operation
c — 500 W SSB gauge 4 for 12V operation

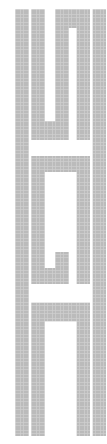
Figure 6 — Minimum wire gauge recommendations in DC installations

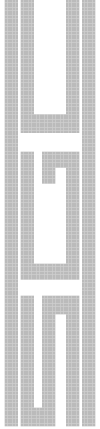
Ground connections. The grounds from the radio chassis, from the coupler ground post, and from the battery minus terminal should all be attached in two places, preferably using braided wire of #0.

Raw metal. The connection to the vehicle chassis should be cleaned of paint and should be scraped to reveal raw metal. If corrosion is likely to be a prob-



Figure 7 — Scrape to bare metal before bolting down ground





lem, fasten the ground system very tightly using self tapping sheet metal screws and large copper washers (to give maximum surface contact). Then lightly dust the area with Krylon™ matte finish or other clear varnish to provide some corrosion protection.

Hinged openings. The doors, hood, and trunk lid should all be grounded to the vehicle using size #0 (AWG) braid or larger. It is important that all parts of the vehicle be bonded together in this fashion.

Exhaust pipe. Take care to ground the vehicle exhaust pipe in several places. If the exhaust pipe is only partially grounded and the car encounters vibration, the vibrating tail pipe can cause irritating electrical noise.

Static cling. Vehicles operating in areas of dry, blowing sand, may occasionally experience static build-up on the vehicle. You may also encounter this phenomenon in a vehicle operated in cold dry climates in the winter months. A static spray (such as is sold in department stores for use on clothing) or other commercially made products may reduce static.

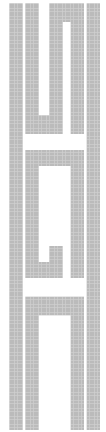
Tires. Tires rolling on pavement may produce static electricity under certain conditions. Although not usually encountered on vehicles using semi-metallic brake pads and disk brakes, it has been known to happen on older style large military vehicles where the axle shaft is insulated from the wheel. Commercial brush kits are available to resolve this condition.

Bumpers. Vehicle bumpers may be made of plastic or plastic-filled metal shells which attach to the vehicle using electrically unreliable fasteners. In many cases, a metal bumper may look like it is grounded but in fact is not.

Moreover, vehicles may have bumpers put on at the assembly plant after a coat of paint or protective finish has been sprayed on the body. Such sound engineering for rust prevention may impede HF radio work because the paint layer

may not be scraped by tightening the bolt, resulting in a poor connection or no connection at all.

Control head. An SG-2000 remote head need not be grounded with a separate cable. The control head and the data lines which are used for control of the radio need only be grounded at the control head plug on the radio. Installation of the control head with grounding should not cause problems, but if one arises, look for a ground loop involving the control head.



Noise Suppression and Shock Mounting

Noise Sources

Three kinds of vehicle noise may be encountered: ground/static noise (eliminated by following proper grounding procedures in Chapter 4); engine noise; and accessory noise.

Engine noise. Ignition noise is a principal source of electronic noise.

Diesel engines: Diesel engines do not make ignition noise, having no high voltage spark plugs (perfect for mobile radio). However, even in diesel-powered vehicles, engine-related noise can come from the generator or alternator.

To eliminate a good deal of vehicle engine-related noise, it is good engineering practice to install RF by-pass capacitors at the battery and across the alternator terminals. The capacitor doesn't need to be especially large: .01 to .1 micro Farad disk ceramic capacitors with a working voltage of 100 V will do just fine. We recommend the use of non-polarized capacitors: these are simpler to install because polarity may be ignored.

Gasoline engines: Gasoline- or natural-gas-powered vehicles have high voltage wiring for ignition spark plugs, which causes a small amount of radio frequency energy to be transmitted each time a cylinder fires. For example, an eight-cylinder car running at 3,000 RPM, emits 12,000 little sparks every minute. Four cylinder cars emit 6,000 sparks at the same RPM.

The noisiest wire in the vehicle is the lead from the ignition

Trouble-shooting Ignition Wiring

Invest in a small inexpensive AM radio. Tune it to the high end of the broadcast band (1610 KHz) and turn up the volume. As you get the radio near the ignition wiring, you will notice a marked increase in spark plug noise. Isolating the problem is the first step toward resolving a noisy engine.

coil to the center conductor of the distributor.

Solutions for Electrical Noise

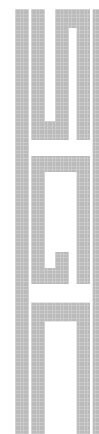
Install the antenna system as far away from the engine compartment as possible. (We recommend the QMS—see Chapter 4 and Appendix A. Not only does it keep the coupler-to-antenna wiring as short as possible, it also puts another layer of metal between the noisy engine and the antenna base.)

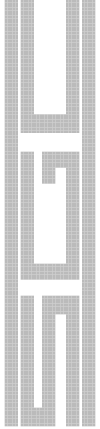
Engine noise. Engine noise can be suppressed with capacitance and shielding.

Capacitance: Apply electrical capacitance. Capacitors will bypass spikes of electricity, such as those pulses which run from the spark plug to ground.

Small capacitors are fine; however, if you add too much capacitance to ground, you will flatten the ignition spike and reduce the intensity of the spark. The arrival time of the spark will also be delayed because the capacitor that you use will slow the rise time of the spark pulse.

With too much capacitance, the spark voltage may drop from 20,000 volts to 5,000 volts, not enough to cause a spark in the engine. Therefore, put a capacitor of .01 micro Farad only on the primary side of the ignition coil.





Shielding: Shielding the ignition system is the next most likely means to reduce noise. (If such shielding becomes necessary, refer to the “Mobile and Portable Stations” section of the *ARRL Handbook*.)

Component noise. Noise originating in other components must be dealt with in other ways.

Grounding brushes: Wheel static may be eliminated with brushes. (See “Tires” in Chapter 4.)

Shutting off accessories: Accessory noise may be isolated by turning on and off items such as heater fans and air conditioners and leaving them off during radio operations.

Shock and Vibration Mounting

The two issues regarding shock mounting are physical displacement and frequency.

Displacement. Displacement is a measure of how far a unit moves when vibration occurs. In a vehicle, displacement may be a small fraction of an inch, on a sailboat 20 feet—if the vessel is operating in 20-foot seas.

Frequency. Frequency is a measure of how often a change of direction takes place. On a vehicle, frequencies may run up to many times per second, on a sailboat perhaps one cycle in two minutes. A high speed paramilitary Rigid Inflatable Boat might encounter shocks at rates of 1 per second or greater, depending on sea state and mission. This frequency requires shock mounting.

To estimate whether a shock mounting is required in a particular installation, multiply the frequency (in cycles per second) times the displacement (in inches). If the resulting number is greater than three, a shock mounting tray should be considered. With a value over five, a shock mounting is mandatory.

SGC 500-watt installation. SGC does not recommend a shock mount in the 500-watt mobile installation. But if you frequently drive back country roads with 5-inch-deep pot holes which cause a vibration factor over 3, a shock mount is required.

Example Calculations of Vibration Factor

1. Sailboat. For a sailboat in a 10-foot sea, with a wave period of one minute, the calculation is:

**120" times 1/60th of a cycle per second =
a vibration factor of 2.**

So in this case, installation of a shock mount is not necessary.

2. Four-wheel drive vehicle. For a military four wheel drive vehicle racing across the back country at 60 miles per hour, the displacement can be three inches and the frequency up to 2 times per second; in this case, the calculation would be:

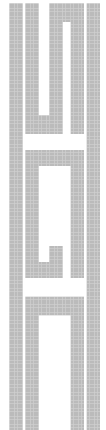
3 inches times 2 = a vibration factor of 6.

A shock mount is obviously needed.

3. Family vehicle. A family vehicle driven on average city streets and highways. would suffer a displacement of 1/2-inch or less. The calculation is:

.5 inch times 2 = a vibration factor of 1.

So in this case, installation of a shock mount is not necessary.



Installation Procedure

The installation of the SGC 500-watt mobile system involves four separate areas:

Engine Compartment:

- Routing the DC cable from the engine compartment to the equipment.
- Installing the “Smart Solenoid”
- Connecting the DC power cable and starter switch.

Driver’s Compartment:

- Installing the control cable.
- Installing the Power Talk control head.
- Installing the SmartLock Pro.
- Installing the PowerTalk speaker.
- Installing the band-selector switch

Exterior:

- Installing QMS with SG-235
- Connecting SG-500 to SG-235
- Installing Ground Strap.
- Installing antenna.

Rear Compartment:

- Installing and interconnecting the SG-2000 transceiver.
- Installing and interconnecting the SmartPowerCube amplifier.

(Installation will be facilitated with SGC’s Go Mobile kits: Cat. No. 52-97 [with battery] or Cat. No. 52-98 [without battery].)

Engine Compartment

Lay out the DC cable lengthwise next to the vehicle to ensure a generous and sufficient length to reach equipment that will

be located in the rear compartment. Strip approximately 1/4 inch of insulation from both leads, and solder a round terminal lug to each lead.

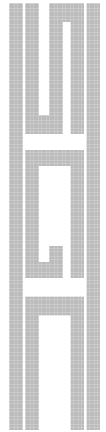
Passing cable through firewall. Locate the point in the *firewall* (the wall separating the engine and passenger compartment) where electrical cables feed through. This is usually somewhere near the steering shaft entrance and will usually have a cable bundle with a rubber grommet encircling it to keep water and wind out.

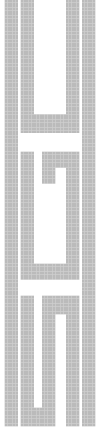
Feed the power leads from the passenger compartment side of the through the rubber grommet to the engine compartment side. If the hole is too tight, *carefully* make a small cut in the rubber to enlarge the hole so that the leads can fit through.

Mounting the solenoid. Next, locate a point inside the engine compartment where the priority solenoid can be mounted. Find a *flat* place, preferably with at least one *existing bolt* installed (such as those used for cable stays and various brackets) that can double as a mounting point for the solenoid bracket. Most of these bolts tighten into pre-threaded holes in the engine compartment. Using one will save you from having to drill holes and to affix washers and nuts.

If no suitable mounting holes/bolts are present, you may need to drill a hole for the mounting bracket. Before doing so, check the opposite side of the metal through which you intend to drill, ensuring that no motors, valves, or other components there might be penetrated and damaged. Also ensure sufficient wrench room (or knuckle space) to affix a washer and nut to the mounting bolt you intend to install.

Connecting leads. Remove both leads from the battery when connecting cables to and from the solenoid. Place a





plastic bag (or electrical tape) over the terminal lugs to prevent them from making contact with either the battery or chassis while you are working.

Insulating tools: Whether you choose to use a socket driver, crescent or open-ended wrench to remove the battery terminals, remember that these are conductive, and may short the battery should they contact the chassis (when loosening the positive terminal), or the positive terminal (when loosening the ground terminal). We recommend temporarily insulating the tool handle by covering it with heat-shrink tubing or electrical tape.

Connecting leads to solenoid: With the solenoid bolted into place, install auxiliary battery lead, main battery lead, started switch lead, and ground wire.

Connecting leads to the battery: If your battery does not have a threaded terminal that you can connect cabling to from the solenoid, there are special battery posts available in most automotive store that can replace the original ones and provide this feature.



Figure 8 — The solenoid bolts into an existing hole in the GEO Metro

Soldering terminals: The large battery terminal lugs that attach to the 4-gauge wire are best soldered in place using a 40 to 60 watt) soldering iron. Do not use crimping-only to install the terminal!

To solder the terminal, first remove about 3/8" of insulation

from the wire, being careful not to damage or cut off any of the strands inside. Place the terminal on the end of the wire, and point the wire straight up. If you intend to install heat-shrink, place a 1" strip on the wire beforehand, as the diameter of the lug will prevent it's installation afterwards.

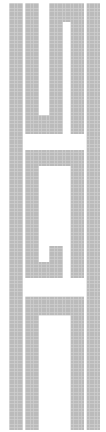
The end of the wire should exit just about even with the end of the crimp on the terminal. Place the tip of the iron on the area heating both the terminal and the wire, then slowly start to apply solder. As the solder melts, capillary action will draw or "wick" it up into the wire strands. Keep a steady supply until the wicking action stops and the solder starts to pool on top. The connection should be bright and shiny, and the end of the wire near the terminal should be stiff from the strands hardened with solder. Heat-shrink tubing can be shrunk in place using a match, hot-air gun, or 1000-watt hair dryer at close range.

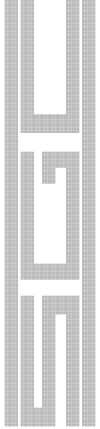
Connect all the cables to the solenoid first, leaving the battery terminals for last.

Before connecting the battery terminals, check the auxiliary battery cable leads are not touching (shorted in the rear of the vehicle) place a plastic bag over each one to prevent this from occurring. Next, connect the positive and negative leads to the battery.

Driver's compartment

Next, remove moldings or panels along the right side of the compartment and route the DC cable from the firewall entrance, along the right side of the car back to the rear deck or trunk. Study the fastener type used in your vehicle. Some panels unlock from each other by special tooth/clips, while others require popping out special push rivets first. If these cannot be removed by simply pulling, you're doing





something wrong. Stop. Examine the fastener more closely to see if it has a center shaft that must be pulled first before removing the remainder of the fastener.

With the moldings removed, you should be able to unclip the edges of the carpeting to expose a small length of the vehicle floor.

Running the cable. Route the cable beneath the carpeting, along the right side of the vehicle floor, all the way to the rear deck or trunk compartment.

Figure 9 — Peel back the carpet in a Cadillac to permit a cable run



Next run the control cables. Then clip the carpet in place again and reinstall the moldings.

Seat Belt Anchor Bolts: In some vehicles, you may find that the large bolts used to anchor the seat belt restraint/feed mechanism may block the routing of cables along the door moldings. Whenever possible, *bypass these bolts* rather than attempting to remove them to facilitate cable feed through.

- Seat belt anchor bolts are specially designed and installed on the assembly line using high torque. They usually have a liquid locking compound applied to their

fine machine threads:

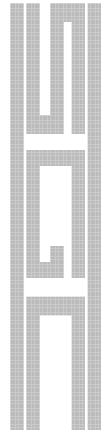
- to ensure their reliability and your safety should impact occur.
 - to prevent them from being easily removed.
- Some bolts use hexagonal cap heads that require the use of a large Allen wrench (usually with a breaker bar for added leverage) or driver for loosening.
 - If removal becomes absolutely necessary, when re-installing the bolt:
Apply fresh thread-locking compound, and tighten the bolt back in place using the torque specified by the automobile manufacturer. Replace and torque all bolts after removal.

Warning! It is dangerous as well as unlawful to permanently disable or remove the seat belt restraint system in vehicles. Don't jeopardize driver and/or passenger safety.

This completes the cable runs that connect your remote control head, car battery and solenoid to the 500-watt installation in the rear compartment.

Installing the PowerTalk control head. The control head can be installed either on a mounting bracket (Catalog No. 04-13) or on an adjustable suction-cup mounting arm for dashboard or window surfaces (Catalog No. 04-25). The control head can be mounted using several methods, which will be dictated by the configuration of the vehicle dashboard. Over-head, on-dash, and below-dash mounting schemes are all possible, but keep safety in mind before choosing the location.

You will want the control head to fit snugly in a location that offers:



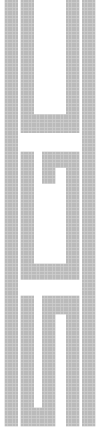


Figure 10 — The PowerTalk head mounts neatly on the GEO Metro dashboard, using suction-cup mount.



- comfortable access to the spinner knob and other push-buttons.
- good LCD display visibility.
- a location which does not obstruct your vision of the road while driving.

Be sure to route the PowerTalk control head cable before installing the head. As before, tuck the cable securely in place beneath interior body moldings, or under the carpet, and lead them back to the Rear Compartment where the SG-2000 transceiver body will be mounted. The size and weight of the PowerTalk head demand a solid surface for either the suction-cup or gimbals mounting method. If using the gimbals bracket, ensure solid sheet metal backing is available. Do not drill nor mount the bracket onto polymer panels or moldings: they will not provide the structural strength and may fracture over time.

Applying windshield suction-cups. To secure the PowerTalk control head and its matching speaker in your, you can take advantage of the remote mounting system (Cat. No. 04-25). This firmly mounts the control head and speaker to the vehicles windshield through the use of high-vacuum suction cups attached to a rigid aluminum plate. Getting just the right viewing angle on the control head is made possible

by an adjustable mounting arm between the base and the control head (or speaker).

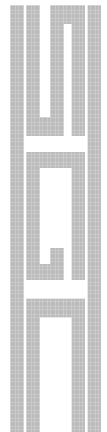
To mount the remote kit, first prepare the windshield surface by wiping it off with glass cleaner. Next loosely assemble the control head to the adjustable mounting arm and lift and position the entire assembly against the windshield. Shift the mount around to determine how high on the windshield the mount should be placed to allow ample room to position the control head for the desired angle. You can mark the position on the windshield with some strips of masking tape or with a stroke from a thin piece of bar soap (which will wipe off easily, unlike permanent markers!). Remove the mount and detach the control head from the adjustable mounting arm.

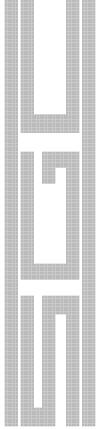


Figure 11— Seen from outside the GEO Metro, the suction cup mounting securely holds the PowerTalk remote head

For better adhesion and sealing, apply a thin coat of Vaseline to the suction cups before pressing them into place (use sufficient force to evacuate all the air from within the cups).

The mounting arm can be adjusted through several axes by loosening and tightening both the hexagonal screws and the wing-knobs. A slight “droop” will occur between the position of a unloaded and loaded arm (that is, with the control head





affixed), so adjust the arm position to compensate for this droop.

Now, go get an assistant to help you: an additional set of hands will prove invaluable in positioning and pressing the mount into place. Use the flat palm of one hand to press the suction cup against the window and flatten it as much as possible. Having your assistant hold the mount in place while you concentrate on pressing the cups flat makes things easier. You can use a long object to lever additional force on the mount (be careful not to mar the dashboard surface in doing this).

If you do not want to have the Powertalk head rest directly on the dash, as with the speaker, you can apply rubber feet or Velcro to cushion the unit and protect the dash finish.

Install the Powertalk head on to the mount, position it, and slowly tighten all hexagonal set-screws and winged knobs so the control head is positioned as desired.

Installing PowerTalk Speaker. The external speaker can be mounted using a variety of methods, depending on the desired installation and available space. The speaker includes a mounting bracket for under-dash or overhead installation but requires drilling two holes for the sheet metal screw fasteners.

An alternate method is to use the suction-cup adjustable mounting arm (Catalog No. 04-14) which attaches to the inside of the window (taking care not to block your visibility of the road). If the speaker will rest on the dash surface, place a small strip of Velcro™ or adhesive backed foam tape to the speaker corners to prevent the head from marring the dash surface from vibration while driving.

Connect the audio cable between the rear panel of the speak-

er and the jack on the rear panel of the PowerTalk head.

Installing the Smartlock Pro. The Smartlock Pro, a small remote control box, allows turning on/off the receiver pre-amp in the SGC antenna couplers and locking or resetting coupler operation.

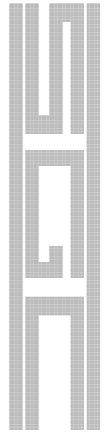
It can be mounted in a convenient location on or below the dash. The simplest method is to make use of Velcro™ hook and loop fastener strips, or double-sided adhesive tape, and cut a square to match the box and dashboard surface. Route its control cable beneath the dash, then to the rear of the vehicle (or where the antenna coupler is installed) via the door edge moldings or under the carpet.

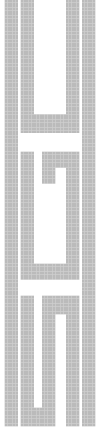
Mounting the SG-500 Remote Control. Included with the 500-watt installation kit (SGC Catalog No. 52-97), a remote control box with cable enables switching the amplifier DC power on and off (with LED indicator) and manual selecting of the appropriate input filter for the band you wish to operate on.

The amplifier on/off switch on the remote control box is wired in series with the on/off switch in the amplifier. To enable control from the box, leave the switch at the amplifier set to “ON.”

Amplifier draws current when idling: When leaving the vehicle, remember to turn off the amplifier: it draws a small amount of current from the battery in its idle state. The red LED on the remote control box provides an easy check of whether power is applied to the Powercube.

If space is available, it may be convenient to mount the remote control near the Smartlock box using the supplied Velcro strips. Route the control cable to the rear of the vehi-





cle with sufficient length to easily reach the Powercube amplifier.

Trim excess lead at the amplifier: When installing the remote control box, *excess lead length will be trimmed at the box, rather than at the amplifier.* This is because the small 4-pin plug used for on/off and LED power is pre-assembled at the factory and should not be cut off and re-wired.

Referring to the instructions provided with the remote control box, connect the six-wire (input filter select) plug to its mating connector on the Powercube, and the small four-wire plug into the pin jumper located next to the PTT/Filter Select switches.

The wires at other end of the cable will be attached to the connector on the remote control box.

Exterior

Unique to the QMS antenna/coupler configuration is its mounting strap system. No other manufacturer presently offers a system utilizing this approach. The QMS system addresses three important aspects of mobile operations:

- Truly efficient, all-band, high-power performance using a proven antenna design with both electrical and mechanical integrity under the most adverse driving conditions.
- Easy transportability from one vehicle to another. The QMS mounting system is “semi-permanent” because its suction cup and strapping allow ready removal of the entire unit. The QMS goes in place, and stays in place, until you need to move it.
- Non-intrusive mounting design. No drilling body panel holes in a \$10,000 to \$20,000 vehicle to accommodate a \$20 fitting, the QMS system allows you to enjoy mobile operation without

depreciating your vehicle's value with unsightly holes, scrapes, and scuffs from magnetic or other mounting approaches.

Preparing to Mount the QMS. The suction cups form one half of the QMS anchoring systems, the nylon straps finish the job. Included with your QMS systems are four plastic-coated steel hooks. The nylon straps loop through these, and the hooks hook onto ledges to form a secure anchor point from which the strap tension is tightened.

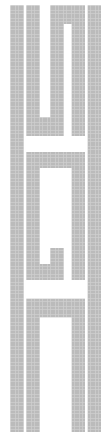
On most compact vehicles (especially a hatchback), mount the QMS box on the left rear side window, with one strap tying to the front door opening, one to the hatchback opening, one to the wheel well (fender), and one either to the roof or to the lower body edge.

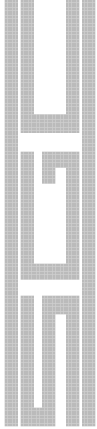
Finding panel edges. Find a body panel edge or "lip" that the steel clip will catch and anchor onto. You should be able to find the edges needed to secure the hooks and mounting straps.

Look under gasket: Try lifting up the rubber sealing gasket that goes around the rear hatch and door openings. Underneath you will find a "knife-edge" strip of metal that may mate well with the metal hooks. In most cases the rubber stripping can be reinstalled without affecting door/hatch closing or proper sealing.

Steel hooks: The steel hooks are flexible enough that they can be slightly bent or shaped to the proper angle to allow a custom fit on the door/body edge of your vehicle. Use a vise-grip and large pair of pliers: try to get the angle right the first time because repeated bending will weaken the steel.

Abrasion-resistant straps: Closing a door or hatch over the





QMS mounting straps may bother you at first, but they are abrasion resistant, and two straps have a total thickness of only about 4 mm, while retaining a tensile strength of over 1000 pounds.

Locating Body Openings for Cable Lead-Through. A multi-conductor cable together with RF coax lead (within one sheath), and a braided strap for RF grounding—within one sheath—must feed from the SG-235 coupler (inside the QMS system) through the vehicle body to connect to the SG-500 PowerCube, SG-2000 Transceiver, and the vehicle ground (chassis).

Pre-existing holes: Notice some pre-existing holes in the vehicle body used for ventilation or for wiring lead-throughs from options that may or may not be installed on your vehicle. Try to utilize these first: it is much simpler than drilling holes in your car.

Knife-edge slot: Locate a door “knife-edge” or lip; file a “slot” just wide enough for a cable to pass. In many instances the rubber sealing strip can be slipped back in place over the cable lead-through.

Installing the SG-235 inside the QMS. The black aluminum QMS serves not only as a mounting foundation for the SG-303 whip antenna but also as a container for the SG-235 Smartuner, offering it additional protection for the coupler. Before starting, ensure that the two side panels are removed from the QMS box, set them aside for now, and be careful not to lose their mounting screws.

Installing Ground strap: To connect the braided RF grounding strap, a good electrical and mechanical connection to the vehicle chassis must be found. The strap is flat and flexible enough to feed through most door/hatch edges without affecting door closure.

Enclosed with the QMS package is a length of braided cable used to provide the electrical connection from the QMS box to the vehicle. On the interior of the QMS box you will notice that one of the bolt hole surfaces is bare, shiny aluminum. Here the terminal lug of the braid attaches to the box, and here a short jumper connects to the ground connection on the SG-235 coupler unit.

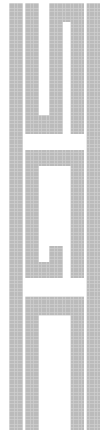
To provide an effective RF/DC ground on your vehicle:

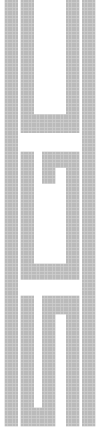
- make a solid electrical and mechanical connection to the vehicle body
- ensure the body is grounded to the vehicle chassis (in newer cars with unibody construction, this is done for you).

Route both the cable and ground strap through the rear hatch or trunk (the weather sealing strip is usually thick enough to accommodate them while still sealing out the elements). Once inside, the cable makes the shortest possible run to the Powercube (in 500-watt installation) or the transceiver. Attach the braid to a readily accessible bolt that ties to the vehicle body:

- Remove the bolt and scrape off a small area of paint around its hole with a thin strip of sandpaper to provide a better electrical connection.
- Use a pencil or ball-point pen to push apart the strands in the center of the braid to form a hole through which the bolt may pass (you can trim the strap and solder on a lug, but this may be inconvenient or impractical).
- Anchor the strap.

Cover exposed strap: Slip a sleeve of heat-shrink tubing onto the braided strap along the length that will be directly exposed to the air and to door-sealing surfaces (8 to 10 inches should suffice). Ground the braided cable to the chassis using existing bolts and screws, when possible. Prepare the contact surface by sanding away the paint and primer until





shiny, bare metal appears.

Secure braided strap: A part in the braid large enough to pass a screw or bolt can be made by simply pushing strands apart with a small pointed object (such as a ball-point pen) to accommodate the fastener. Remember to re-tighten any bolts or screws firmly in place. (See Chapter 4 for details of mobile grounds.)

In vehicles with steel frame construction, you will also want to run a ground strap from the body to the frame. If you choose to connect the grounding strap to the vehicle trunk or hatch lid, remember that these may ride on nylon bushings which will insulate the lid from the body. Therefore an additional ground strap from the hatch to the body may be needed.

Mounting the QMS. Follow these steps in mounting the QMS:

1. Attach the SG-303 antenna base to the QMS box using the supplied screws. Assemble the polymer feed-through bushings and nuts loosely onto the cable and the QMS, but do not lead the cable through the box or tighten the bushing and nuts yet.

Caution: Do not attempt to use a QMS-2-150 (a unit not rated for 500 watts) with an SG-235 for 500 watts.

Warning: Attempting to use a QMS not manufactured expressly for 500 watts could seriously damage our QMS or your amplifier and will void the equipment warranty.

2. Slide the SG-235 unit into the QMS so that the porcelain antenna feedpoint insulator *is on the same end as the hole for the antenna cable feed-through.* (Note: the QMS system can be mounted either vertically or horizontally; howev-

er, the coupler can only be installed one way within the box to keep the length of the antenna feed wire between the SG-235 and the mounting base of the SG-303 whip *as short as possible*).

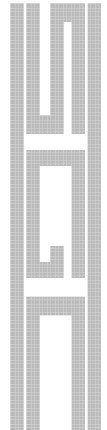
3. Align the four holes in coupler mounting bracket with the four holes in the QMS bottom. Now install the four suction cup feet to the QMS box—the mounting screws inset in their feet fit through both the box and coupler bracket holes. Fasten each foot with an appropriate bolt.

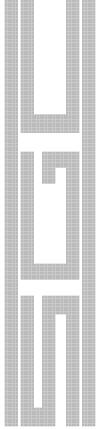
4. Trim the length of feed wire from the antenna mount so that it will reach the porcelain stand-off insulator on the coupler through the polymer feed-through bushings with the antenna base unlocked and swiveled in the *rearward* position (farthest possible extension). Solder the terminal lug (supplied) to the end of the antenna feed wire and then bolt it to the porcelain stand-off insulator on the coupler —using only minimal force. (**Caution: the porcelain stand-off can crack from excessive torque.**)

5. Construct a 2- to 3-inch ground strap which will ground the coupler unit to the QMS box (and vehicle body/chassis) by soldering terminal lugs on each end of the strap. Next, bolt one end of the jumper to the coupler, then the other end, along with the long ground strap, to the QMS at the hole with the bright exposed surface. Attach the two side plates to the QMS box with their corresponding screws. The QMS unit is now ready for positioning and attachment to the vehicle.

Using the QMS Suction Cups. The suction cups of the mounting system set the QMS system apart from any other HF mobile antenna system. The innovative decision to utilize suction cups to mate the QMS box to the vehicle surface stemmed from the several functions they perform:

- This *semi-permanent fastening technique* leaves





the vehicle surface free from blemishes or penetrations (does not detract from your car's resale value). When you need to move or remove the system, it leaves behind no rusted holes that require body work or repainting. Many people have multi-car families—it's reassuring to know you can switch systems between vehicles whenever your requirements change.

- *High adhesion strength* results from the large surface area and high vacuum obtained from the quality suction cups. (Climbers scale buildings and workers carry plate glass using similar high-quality, commercial suction devices.
- *Safely absorbs vibration and cyclic loads* while driving. The silicone content of the cups absorbs the stress and strains imparted by impact with road bumps and potholes that causes premature failure of nuts, bolts, or sheet metal screws used in conventional systems. This principle applies in military and commercial installation through the use of "shock mounts." The large size of the box and spacing of the suction cup/feet spread these forces out over a larger surface area for maximum safety and strength.
- *Noise insulation* : the suction cups dampen the noise and vibration from the QMS box and antenna that would otherwise be conducted to the vehicle body through mechanical joints, affording quieter operation.
- The tie-down strap and suction cups work hand-in-hand as a *constant-tension system*. The tie-down strap tension keeps the cups compressed so their vacuum holds the QMS in place; the flexibility

and “springiness” of the silicone presses back against the tie-down straps to keep them taut and to maintain their tension.

Mounting the Suction Cups. The compression of the suction cups (how strong is the vacuum) and the quality of the seal (how well they match the contour of the vehicle) will determine their performance.

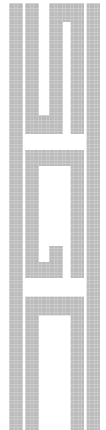
To attach the suction cups to glass, prepare the surface by first wiping it with glass cleaner and a soft rag. If the glass is older, or has been waxed many times, filmy deposits of dust can be removed with the gentle and careful application of a straight-edged razor blade. Wipe everything clean when you are done.

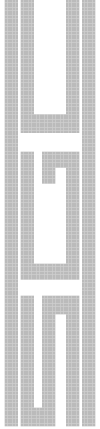
Apply considerable force to compress the cups into place. If you can get the assistance of a friend, let them hold the QMS box in place while you concentrate on the suction cups.

You can apply a thin coat of petrolatum-based Vaseline over the suction cup to enable a better seal. This will also make it easier to slide the cups slightly for final positioning. Don't worry about smudging the glass for now, as you can tidy things up later.



Figure 12 — Apply firm pressure to expel air from the suction cups





Compress the cups by using a steady force, don't pound on the QMS box. Ideally, the suction cup should be collapsed and flattened out as much as possible, although in most installations there will almost always be a small amount of residual air trapped inside. If you apply Vaseline to the suction cups beforehand, and are mounting the QMS box to a window, you can see how much the cup has collapsed by viewing it from the inside. The outline of the air "bubble" inside will be readily visible. The smaller the bubble, the better the seal and the stronger the cup will hold.

A properly installed box will be self-supporting (without the tie-down straps) *and cannot be removed by moderate tugging and pulling.*

Mounting QMS Straps and Hooks. The suction cups form one half of the QMS anchoring systems, the tie-down straps finish the job. Included with your QMS systems are several plastic-coated steel hooks. The tie-downs loop through these, and the hooks hang onto ledges to form a secure anchor point from which the strap tension is tightened.

For most compact vehicles (with a hatchback), you will want

**Figure 13 —
Suction cups can
adhere to the
body of the GEO
Tracker. The
straps maintain
pressure on suc-
tion cups.**



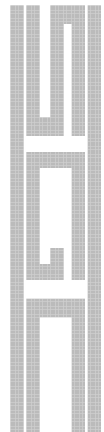
to mount the QMS box on the rear side window, with four straps tying to a front door, hatchback, wheel well (fender), and one either to the roof, or to the lower body edge. For mini- or full-size trucks, the unit can be attached just about anywhere along the periphery of the bed. For mid-or full-size sedans, the trunk lid is more convenient.

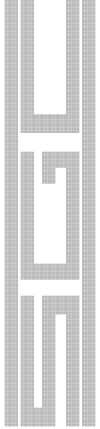
The key to this part of the installation is finding a body panel edge or “lip” that the steel hook will catch and anchor onto well. With a little bit of exploration and ingenuity on your part, you should be able to find the edges needed to secure the hooks and mounting straps.

Try lifting up the rubber sealing gasket that goes around the rear hatch and door openings. Underneath you will find a “knife-edge” strip of metal that the metal hooks often mate to quite well. In most cases the rubber stripping can be replaced without affecting door/hatch closing, or proper sealing. The steel hooks are flexible enough that they can be slightly bent or shaped to the proper angle to allow a custom fit on the door/body edge of your particular vehicle. Use a vise and large pair of pliers to do this. Try to get the angle right the first time, as repeated bending will stress weaken the steel.

The prospect of having a door or hatch close over the QMS mounting straps may bother you at first, but please realize that they are abrasion resistant, and two strips have a total thickness of only about 4 mm, while retaining high tensile strength.

Positioning the QMS. When mounting the QMS on vertical glass surfaces, such as the rear side windows, the box has a tendency to slide downward slightly over time. Mount the QMS so that its suction cups rest at the bottom of the window, where the glass meets the window sealing strip. In this





“natural resting position,” the QMS can be secured firmly, and will slide no further.

Tightening the Straps. Now comes the moment of truth: the QMS is positioned, the suction cups compressed, the tie-down points are determined, and the mounting hooks angles are adjusted as necessary.

1. Loop each tie-down strap through the its corresponding opening in the top and side of the QMS , through the steel mounting clip, and plastic buckle. On the buckle, the strap must enter from beneath, loop up and over the guide, then exit from beneath as well.

2. The tie-down buckles can face either toward or away from the QMS box, but for convenience and appearances sake, choose a common direction that allows you to tighten them as directly as possible.

3. Make sure that straps align perpendicular from any curves (such as wheel well ridges). With the strap at 90 degrees relative to a curvature, it can shift no further laterally and will retain strap tension.

4. Take up the slack from all four tie-downs so there is enough tension to keep the straps in place, but don't pull them home just yet.

If the QMS is positioned vertically, like on a side window, start with the top straps first, tightening them only to the point where firm resistance is met—then stop. The final ten-

Caution: The tie-down straps and the steel hooks are quite strong. The sheet metal that forms the lips of your wheel well, door or hatch may deform or bend under the tension of an over-tightened tie-down strap.

sion can be applied from the bottom straps (why work against gravity?).

If the QMS is mounted on a horizontal surface, such as a roof or trunk top, start tightening the straps in any order. Pull the straps as tight as possible, so that as little “play” as possible when the straps are pushed in from their center.

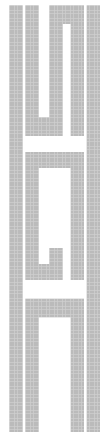
The idea here is that it is sometimes easy to get carried away with over tightening the straps. After each consecutive “pull,” feel the strap tension, and look at the lip or edge that the steel hooks ride on to see if the steel is showing signs of bending or deforming. If so, back off the tension a bit. Remember, the suction cups are the primary devices that are fastening the QMS box to the vehicle. The straps are there just to keep the cups compressed.

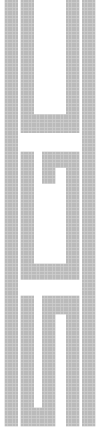
Tighten twice: Tighten set-up straps initially, then once again after a day or so of driving. Some play and stretching will occur after the initial tightening, so the second one will actually be the “final” one to take up any slack for the duration.

You can snake any excess strap length back inside the QMS box, trim it off with a pair of utility scissors or sharp knife, or roll or fold up the excess length and secure it using nylon wire ties.



Figure 14 — Tighten straps to maintain pressure on suction cups. Plan to retighten straps after dri-





Nylon wire ties wrapped around the straps keep them from “fluttering” at high speeds and neatly bundle the coupler cable and braided ground strap along with the tie-downs. Clip off excess tie. (See Appendix A for additional information on the QMS installation.)

Mounting the SG-303 antenna. The antenna which screws into the QMS ratchet mount is not a temporary installation.

Assembling the antenna: To assemble the SG-303 antenna, use wrenches to tighten the two sections together.

**Figure 15 —
Tighten the two
sections of the
whip with wrench-
es**



Caution: A hand-tightened antenna will permit movement which can break the antenna ferrules. If the whip is too loose, you can feel it flap when it passes its vertical point.

Installing the antenna: Installing the SG-303 antenna requires two people: one to hold the rubber boot and the other to tighten the antenna into the ratchet mount, using a wrench.

Figure 16 — One person grasps the rubber antenna base to prevent its turning while a second person tightens the whip with a wrench

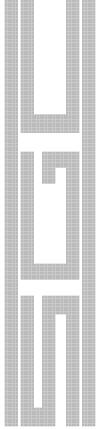


Caution: a hand-tightened installation will permit movement which can fracture the bottom of the antenna.

Worrying about theft: Some people worry that the QMS and the SG-303 antenna are easy targets for theft. In fact:

- Removing the antenna for safe storage violates the permanence of the installation and invites damage to the antenna.
- Having received no reports of the theft of the QMS or its antenna, SGC concludes that it is more likely that your car's seats or its wheel assemblies will fall victim to a thief than your QMS and SG-303.

Using body openings for coupler cable and braided ground strap lead-through. The QMS system has several leads from the SG-235 coupler that must feed through the vehicle body to connect to the SG-500 PowerCube, SG-2000



Transceiver, and vehicle (chassis) ground. These consist of a multi-conductor cable together with RF coax lead (within one sheath), and a braided strap for RF grounding.

As we advised in Chapter 1, you have identified some pre-existing holes in the vehicle body, holes used for ventilation or for wiring lead-through from options that may or may not be installed on your vehicle. Try to utilize these first, preferable to drilling holes in your car. Another idea is to locate a door “knife-edge” or lip and file a “slot” just wide enough for a cable to enter. In many instances the rubber sealing strip can be installed back in place over top of the cable lead-through.

The importance of the braided RF grounding strap cannot be over-emphasized—a good electrical and mechanical connection to the vehicle chassis must be found. The cable is flat and flexible enough to feed through most door/hatch edges without affecting door closure. A good idea is to place a long sleeve of heat-shrink tubing onto the braid along the length that will be directly exposed to the air and door sealing surfaces (8-10 inches should suffice). Try to ground the braided cable to the chassis using any existing bolts and screws, when possible. Prepare the area where the braided surface will contact by sanding away the paint and primer until shiny, bare metal appears.

A part in the braid large enough to pass a screw or bolt can be made by simply pushing strands apart with a small pointed object (such as a ball-point pen) to accommodate the fastener. Remember to re-tighten any bolts or screws firmly.

Rear Compartment

Mounting components on platform. The system components were mounted on a removable platform constructed from a sheet of 1/2 inch plywood cut to match the dimen-

sions of the rear deck or trunk of the vehicle. This platform permits disconnecting and moving the system in and out of the vehicle when necessary (although the added weight of the battery requires two people to lift). In addition, it leaves the original carpet or deck of the vehicle unblemished from screw or bolt penetrations.

Upholster the platform to match the interior of the car. We used a heavy-duty staple gun and a hot-glue gun for attaching the upholstery. Check in automotive stores for a roll of carpet you prefer.

Drill two holes in the “L” bend of the supplied steel hooks (SGC installation kit, Catalog No. 52-97). Mount them vertically on the plywood using self-tapping wood screws, and double as tie down points for the battery, transceiver, and amplifier. Make sure the screws do not protrude from the bottom of the platform, where they could cut your vehicle’s carpet (or you).

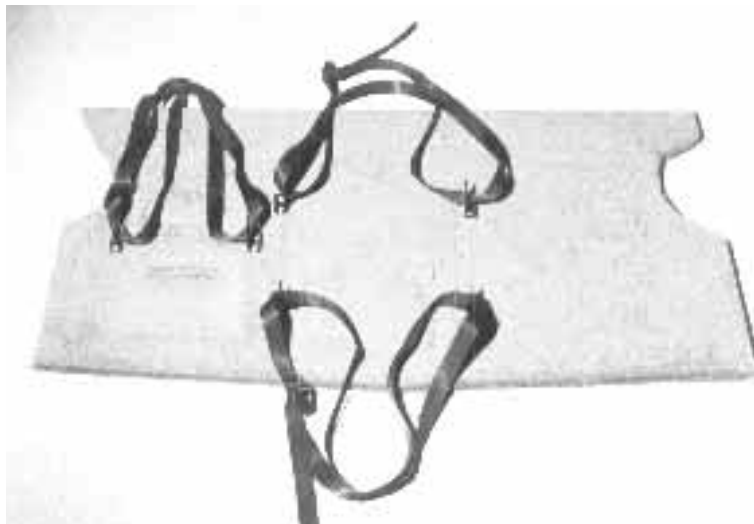
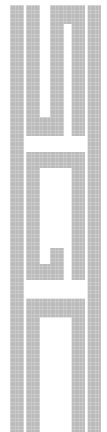
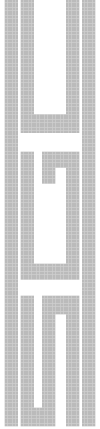


Figure 17 — Construct a board, using hooks and straps to secure equipment in the rear compartment





If possible, try to use self-tapping wood screws that do not require a pre-drilled hole, because drill bits and carpet fabric do not get along well. A power driver or reversible drill with screwdriver bits can expedite driving the screws into thick wood.

Straps that provide anchoring in both horizontal directions (side-to-side, front-to-back) work best, but be sure the straps do not block cable and plug connections. After tightening the straps, you can trim off excess length, or else fold up the excess and use nylon wire ties for neatness.

When completed, the assembly remains in place fairly well, due to the weight of the gear and friction between the deck and platform carpeting. For additional friction and clearance, you could install small rubber feet on the platform.

Your custom-designed platform will offer security, portability, and protection for your 500 watt mobile system.

Making DC cable and control connections. Connect the positive and negative leads of the DC cable to the auxiliary battery.

Caution: Although the 12 to 13 volts present on your vehicle's battery poses relatively no shock hazard, the large current it produces should the battery terminals short can cause the battery to explode and to splatter sulfuric acid that can burn the skin and eyes and result in permanent scarring. The arc created from a shorted battery lead can weld metal together and in seconds can heat wiring hot enough to ignite insulation and fabric. Because there is no internal fuse or breaker in a battery; your safety depends on the precautions you take before connecting or removing leads to the battery.

Installation Variables

In preparing for this book, SGC installed the SGC 500-watt system in four vehicles: GEO Metro, GEO Tracker, Jeep Cherokee, and Cadillac.

We sought to document installation procedures and difficulties encountered during each separate installation. The information in this book represents the experience of having actually performed the installation in the vehicles covered.

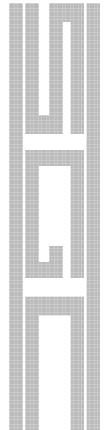
Of course, no installation goes exactly as planned. After all, although communications equipment can be designed for vehicles, most vehicles are not designed for communications equipment. We hope this book will “fill the gaps” in typical installation guides.

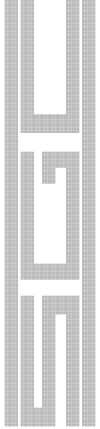
Taking this into account, along with the realization that a little ingenuity—and scraped knuckles—are needed for such installations, go forward in your installation with a willingness to take the time to get it right the first time. Remember the three “P’s” needed for a successful installation: patience, perseverance, and perspiration.

Geo Metro

Typical of most compact cars in this class, installation space both on both sides of the firewall is at a premium.

Engine compartment. To locate a mounting place for the battery separator solenoid and a feed-through point in the firewall for the auxiliary battery cable, we found an existing bolt located on the left wheel well that provided a good mechanical and electrical (ground) tie point for the solenoid.





Near the upper left side of the firewall we located the main feed-through for the vehicle's electrical wiring harness. A large rubber grommet or "boot" seals out the elements, and also protects the cable bundle from the sharp edges of the cutout in the firewall. We enlarged the opening to accommodate the auxiliary battery cable.

We sealed up the opening in the rubber feed-through grommet with some silicone rubber.

Driver's compartment. We divided the cables between the left and right sides: DC cable to the right, control and Smartlock lines to the left. We routed both underneath the removable plastic moldings along the door frames. We wanted to avoid exposed cables, which run the risk of getting caught up in either the driver or passenger's feet, fall behind the brake or accelerator pedals, or crossing the steel rails that hold the seats.

The GEO Metro uses "bulls eye" style plastic inserts that have a center locking post. To release the fastener, use a ball-point pen to press in on the center, pushing the release post in, then pulling the fastener (in its entirety), up and out.

We were careful about securing the auxiliary battery cable and the other control cables beneath the dashboard. Under the dashboard we found a multitude of tie points to be utilized.

Starting at the front and moving rearward, we stuffed the cables down along the door edge. When we reached the rear seat, we had to partially remove the seat to create a opening to access the rear compartment. With the cable bundle now in the rear compartment, we replaced the rear seat.

Exterior. We mounted the QMS on the left rear window and panel. We attached the mounting hooks to the roof trim and the wheel well. We cinched down the straps so the car rocked

when we heaved on the QMS. We installed the antenna, one person holding the QMS while the other tightened the antenna ferrule with a wrench.

Rear compartment. With the SG-500, Slimpak, and battery already strapped down, we lifted our mounting board into the compartment. We routed the auxiliary battery cables and the control cables to their respective terminals/connectors, and trimmed off any excess so they just reached their destinations.

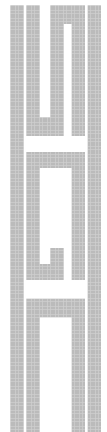


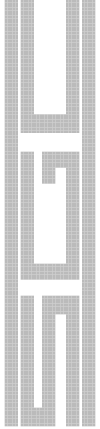
Figure 18 — The 500-watt system fits neatly in the rear compartment of the GEO Metro

With a good quality wire stripper and a sharp knife, we cut the cable to length, removed about two inches of insulation from the end of the cable by making a small incision around the plastic insulating sheath, being careful not to cut into the multi-conductor wiring beneath. We exposed the wiring, surrounded (shielded) by stranded wire braid that served as a ground wire.

It took about 1/4 “ of exposed wire to insert into each plug-in connector terminal on the SG-2000. We tinned the wire-ends before inserting them.

When all of the equipment was securely in place, we connected the control cables and coaxial cables. Only then did we





connect the auxiliary battery cable to the battery.

We started the Metro and ran it for several minutes to get the charging system up to capacity. We turned on the radio and ran through preliminary checks as described in the equipment operating guides *first with the amplifier off*. We ran the SG-235 through its paces to get initial antenna match settings memorized for each band. When a “tuned” indication appeared for each band, we moved on to high-power tests.

(See data sheet, Appendix C.)

Cadillac

Cadillac installation allowed generous space in the driver’s compartment and rear compartment. Engine compartment space, however, proved cramped.

Engine compartment. We routed the auxiliary battery cable through the firewall by cutting a small hole in the steering column rubber boot. Once pulled through, the cable attached to the upper side of the boot cutout to prevent the flex joint of the steering shaft from abrading the cable. (Abraded insulation could cause a short to ground of the battery cable.)



Figure 19 — The solenoid mounts next to the Cadillac battery

We mounted the separator solenoid on the battery shelf securing bolt. We carefully routed all #4 cables away from the engine fan belts and pulleys.

We replaced the stock battery terminals with after market ones which provided an extended threaded stud for attaching lugged electrical terminals.

To facilitate the solenoid connection to the starting switch, we found the wire from switch to starter and in a convenient place spliced in the solenoid lead.

Driver's compartment. Moldings had no exposed fasteners. We removed them by firm but careful lifting.

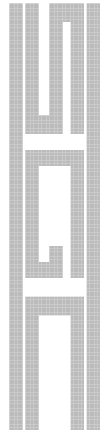
The large dashboard provided generous space in mounting the PowerTalk control head, a speaker, Smartlock, and remote control box. However, the steep angle of the windshield made it difficult to insert the mounting plate and affix the rubber suction cups due to limited working space.

Exterior. We mounted the QMS assembly on the left side of the trunk lid so the mounting straps would not block the view of the license plate. We routed the braided grounding strap under the trunk lip and attached it to two existing bolts which secure the automatic trunk lid closing/locking servomechanism. (We accessed it by removing a molded plastic cover by popping out three plastic fasteners.)

The QMS box was grounded to the trunk lid using the two bolts which secure the underside of the lid to its hinging arm. (Loosen one bolt at a time to prevent springing the lid out of alignment.)



Figure 20 — To connect the solenoid to starting switch, we opened the cable run and spliced into the ignition switch-to-starter line



Rear compartment. We further grounded the trunk lid to the vehicle body/chassis by running an additional braided strap to an existing bolt on the left side of the trunk interior. We loosened a small plastic fuse block to facilitate access to this bolt.

Figure 21 — Scrape to bare metal beneath trunk lid bolts before running ground strap



Jeep Cherokee

The Jeep Cherokee installation proved to be more difficult than the Cadillac but easier than the GEO Metro. Increased interior space and the unique “fold-away” rear seats made access to the rear deck easier.

Engine compartment. The battery separator solenoid was mounted behind and below the fuse block (next to the battery) in the engine compartment.

A feed-through point in the firewall for the auxiliary battery cable was found at the top right side of the engine compart-

ment, next to the brake vacuum booster assembly. The rubber boot of this existing feedthrough was enlarged to accommodate the battery cable, and routed through to the passenger compartment.

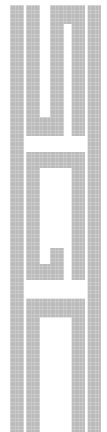
Driver's compartment. Plastic moldings were affixed in place with plugs, and were removed by popping them out.

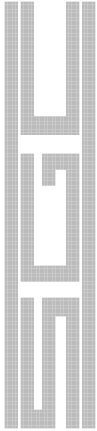
Exterior. The QMS box was mounted on the rear left window, with mounting straps running vertically from the wheel well to the top deck. The control cable and braided ground strap were fed through a narrow slit where the metal body and molded quarter panel are joined. The control cable entered the rear deck through the modified plate cover described below.

A convenient feed-through point for the QMS cable and ground strap was found in the interior compartment of the Cherokee. Located on the left rear panel at the bottom is a pop-out plastic access plate for a fuse block. Below this is a metal plate that can be removed, allowing cables and the



Figure 22 — The 500-watt installation fits neatly into the Cherokee rear compartment





grounding strap from the QMS box to enter and pass through to the rear compartment. The small metal plate was modified so that the cables could pass with the plate re-installed.

A tie point for the braided ground strap leading from the QMS box was located on the interior of the rear wheel well.

Rear compartment. Battery, slimpak and SG-500 tuck neatly into the rear compartment of the Jeep Cherokee.]

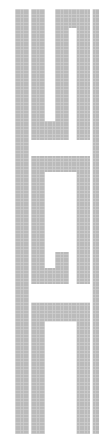
GEO Tracker

Despite its small size, the GEO Tracker offers a roomy engine compartment and many installation possibilities due to its rear deck and hard- and soft-shell options.

Engine compartment. We grounded the chassis to the hood of the Tracker. Inside the engine compartment, the firewall and wheel wells offer many existing bolts that can double as smart solenoid tie-down points. In addition, several unused firewall penetrations with easily-removed grommets permitted the auxiliary battery cable to pass to the passenger compartment. We tried to route the cable far away from the ignition coil: our vehicle's unit proved exceptionally noisy.



Figure 23 — A ground strap connects body to hood of the GEO Tracker



Driver's compartment. The Tracker interior uses a combination of plastic inserts and regular self-tapping screws to secure the carpeting, door moldings, and side panels. We routed the battery cable along the door edge to the rear compartment, while we routed the control head, Smartlock and Remote control box cables behind the center console, beneath the carpet, and then to the rear deck.

Exterior. Because our Tracker version had a soft top, we mounted the QMS box on the vehicle body, above the rear left wheel. However, if your Tracker has the hard shell top, the box could be mounted on its rear left side. Tie points for the braided ground strap were found along the inside of the fender skirt and below the rear deck carpeting.

Rear compartment. We decided to bolt mounting strap hooks directly to the floor of the Tracker. In addition, we screwed straps into the body to hold cables in place. We were seeking security. Soft-top off-road vehicles offer decreased protection from forcible entry, vandalism, and theft.

Danger of theft: Although SGC has not received any verified reports of theft of the QMS antenna system, mobile HF (as well as cellular telephone, CB and off-road/performance vehicle) operators run the risk of increased attention being drawn to their vehicle. It would take a dedicated (and exceptionally fit) lone thief considerable time to dismantle and haul away an SGC 500-watt system, the possibility exists that your vehicle may be a target for theft.

Ways to protect your vehicle: Although we have emphasized the portable, non-invasive board-mounted system secured with the tie-down straps, components can be "hard" mounted, using brackets and metal straps for a more secure, more permanent installation.

Screwed-down installation: Solid panels of body sheet metal can be drilled and self-tapping or machine bolts can be

installed to secure the transceiver and its components. Screw-down cable clamps can secure wiring runs and prevent them from being easily ripped out.

Concealment: Cover the gear from sight with cloth pullovers. A vinyl wheel cover fits over the gear nicely and can usually be had in a color that matches your interior. Covering the Powertalk control head, transceiver, and amplifier with even a small towel not only serves to conceal their identity but also shields them from the heat of long, direct exposure to sunlight.



Figure 24 — Neutral-colored material keeps the 500-watt installation out of sight in the GEO Metro

But remember to afford the gear ample ventilation when in operation.

Precautions: Most criminals won't steal what they can't recognize, and amateur radio equipment usually lacks the high visibility and quick pawn/resale value of cellular telephones, radar detectors, and sound systems. However, it pays to be safe.

- Invest in a simple alarm system—flashing dashboard LEDs and window warning decals are good deterrents to those contemplating a break-in.
- Record the serial numbers of all your communica-

tions gear, and if possible, take a few pictures of your installation, showing all of the gear clearly in place. Should theft or vandalism occur, this offers additional proof to your insurance company of your investment.

Non-SGC Transceivers

SGC wants its equipment to be universal. To show that various other HF transceivers work in our demonstration cars, we installed and tested four foreign-manufactured amateur radio transceivers for operation and compatibility with the 500-watt mobile installation.

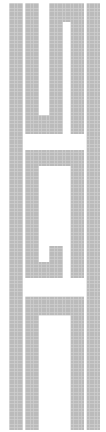
The Alinco DX-60, Yaesu FT-900, Kenwood TS-50, and Icom IC-706 were each used to conduct performance tests.

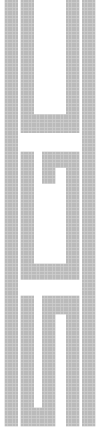
Additional Connections. Each rig has unique mounting and operating schemes.

Coax jumper: All require a coax jumper to be constructed for connection to the SG-500 RF IN jack, 12 VDC for power, and a PTT line. For coax runs longer than a few feet, we recommend the use of high-quality, low-loss cable such as RG-8 or RG-8X.

Mounting brackets: In many of the compact amateur radio transceivers, the mobile mounting bracket or front panel separation kit is supplied only as an option, so be sure to check with your dealer when purchasing the equipment.

The PTT line: The Push-to-talk line, which closes a set of contacts when the microphone is keyed, was readily available on all of the rigs via a rear-panel jack. Although some radios may require a special DIN-type plug to access the PTT line, many use the common RCA audio-style plug available at most electronic stores.





Yaesu switch: The Yaesu FT-900 requires that a small switch (accessible through its bottom cover) be thrown to bring the relay contacts in line with the rear-panel TX GND jack. (In this rig, the PTT jack keys the transmitter rather than providing signaling info—so, use the TX GND jack).

Check in the documentation supplied with each rig for the proper terminals, connections or settings to use for connection to a linear amplifier.

Used with SG-235 and SG-500. When using a transceiver with the SG-235 antenna coupler and the SG-500 Powercube, the amplifier is keyed from the transceiver *via the SG-235 coupler* using a dedicated control (PTT) line. This keeps the amplifier in line as long as the PTT is pressed, so that RF sensing is not lost between voice “peaks” during SSB operation.

From the SG-235 coupler, the gray wire (PTT output) connects to terminal labeled PTT on the SG-500 front panel. The brown wire (PTT input) connects to the appropriate terminal available on your transceiver rear panel (this may be labeled TX GND or PTT OUT on some transceivers—check with their supplied documentation).

Used without SG-235. If you are not using the SG-235 in your installation, the keying line should run directly from the transceiver to the PTT terminal on the SG-500 front panel jack.

Power Control. Most amateur transceivers provide a front-panel variable TX POWER control that permits adjusting transmitter RF output from approximately 5 watts to 100 watts carrier.

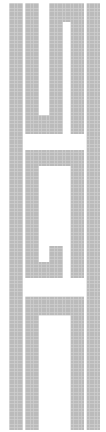
Tune with amplifier off: With the SG-500 switched off, tune to each of the amateur bands, select CW or AM mode, and

transmit to force a tune match combination at the antenna coupler to be memorized for each band.

Select filter: Select the appropriate input filter selection on the SG-500 by rotating the knob on the switch box.

Adjust power with amplifier on: Now you can switch the amplifier on and adjust the input power level, for the desired amplifier output level. Remember, only use the minimum power needed to maintain reliable communications!

Performance. All four transceivers worked well in the GEO Metro installation.



Going Mobile at 150 Watts

Although this book set out to overview the installation of a mobile 500-watt system using SG-2000 Powertalk transceiver mated with a SG-235 Smartuner and SG-500 Powercube, we should mention “barefoot” 150-watt systems.

The same advice and procedures covered on cable routing, mounting methods, and vehicle configurations still apply to lower power systems. The overall installation will be almost the same, leaving out the SG-500 of course, and perhaps substituting an SG-230 for the SG-235.

Auxiliary Battery

The big question will probably be, “Do I need an auxiliary battery system?” A 100 to 150 Watt HF transceiver typically draws 16 to 24 amps on transmit (CW). This is about one fourth the current requirement that its big brother, the 500-watt Powercube, draws on transmit. Although an unmodified vehicle charging system can easily handle this load, you may want to consider adding the auxiliary battery/solenoid system anyway. (See Chapter 6.) A few factors favor this suggestion:

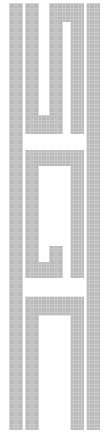
- Adds reliability of a *backup power source* for cold-weather starting and emergencies. Operators in regions with sub-zero winter temperatures may want to consider this.
- Allows for easier future installation of the Powercube, should you someday decide to upgrade to 500-watts.
- Reduces overall battery drain and allows

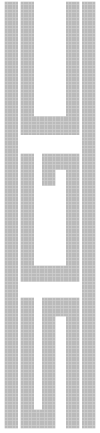
extended operating time (battery life) if you intend to operate with the ignition off or with the vehicle just idling (campers and mountain-top operators take note).

- Makes a relatively inexpensive investment. High-quality automotive batteries (usually with a 36- to 48-month year guarantee) can be purchased at a bargain at various stores. Considering their initial cost divided over a several year operating life, they represent a good value for the serious mobile operator.

Information Applies

Whether you choose to install a smart solenoid and auxiliary battery or not, the information presented in this book applies to your mobile installation. Once again, we cannot overemphasize the importance of knowing your vehicle configuration and layout, planning your installation beforehand, and taking your time. Cutting corners will come back to haunt you, and may be dangerous.





QMS System

Introduction

SGC's QMS (Quick Mount System) represents high reliability backed by over 25 years of communications experience.

Unpacking QMS

We recommend unpacking the QMS antenna system and inspecting the contents. This is necessary to ensure that no damage has occurred due to shipping and that all items are accounted for as verified from the packing list as follows:

- One QMS Manual
- One Warranty Card
- One QMS Black Anodized Assembly complete with four straps (each two feet long)

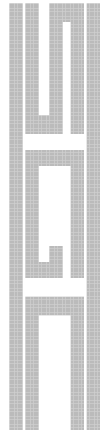
Note: If the QMS is purchased in a package configuration (QMS-2 or QMS-3), please refer to the SG-235 and SG-303 manuals for their respective packing lists of the items supplied.

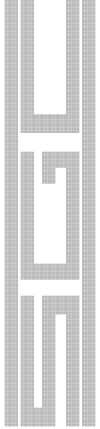
QMS Installation Instructions

The QMS (Quick Mount System) antenna and coupler system can be mounted in virtually any location convenient to the user. Some consideration may be given, however, to the items listed below:

Installation Considerations. Consider the following five principles.

1. Locate the QMS system as far from the engine as possible. This should reduce interference generated by the engine, spark plug noise, etc. from getting into the antenna system.
2. If possible, mounting your QMS in an area clear of





objects will reduce the danger of damaging the QMS. For instance, if driving in rough terrain, the QMS is likely to be hit by trees, stumps, or rocks. If the unit were mounted on the back of the vehicle, damage would be less likely to occur than if a side mount was used.

3. If you will be traveling in an area where overhead restrictions may prevent use of your SG-303 antenna, the antenna should be folded down and secured to prevent damage from brush, trees, or low structures.

4. When connecting the coupler to the radio/transceiver, a passageway for the control cable (consisting of an RG-58 coax cable, control wire, power, and ground, plus the optional tuned indicator wire) will need to be provided.

5. Once a location for the QMS has been selected, mounting becomes a simple task. The QMS enclosure mounts in virtually any attitude and the straps can be moved to either side of the enclosure to accommodate the vehicle .

Installation Precautions. To ensure safe operation of your QMS system, the following installation, mechanical, and electrical precautions should always be taken:

1. Insure that all four straps are pulled down tightly and the suction cup feet have been securely compressed.

2. Insure that the high voltage wire protruding from your antenna system is not routed near any metallic objects such as your vehicle's frame or metal posts. This wire is part of the flexible insulator of your QMS system.

3. Insure that the ground braid is attached to a good

vehicle ground system. Do not run ground currents through any hinges. Be sure to make the ground braid as short as possible. Remove all paint and rust from your grounding area. Remember, your ground system is one half of your antenna system.

4. Locate the control wire to the QMS, from the transceiver/radio, away from any other wiring inside your vehicle. This control wire contains a high power RF coax cable which can radiate into other wires (such as your head-to-transceiver control cables) causing feedback in your transceiver.

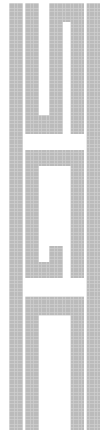
5. The webbing, buckles, and hooks of your QMS have a rating of 1,000 pounds. Ensure that the hooks are attached to a suitable structure, such as a trunk lid, or something that will not cave in when the straps are pulled tightly to secure the unit.

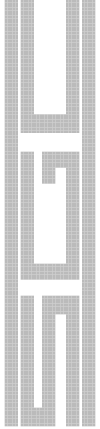
6. When locating the gutter clip (which secures your SG-303 antenna when not in use), mount the unit in a location where the tip of the SG-303 antenna is easily accessible for threading through the "O" ring. Failure to secure the SG-303 antenna could result in damage both to the antenna and to your vehicle.

7. When the QMS system is securely fastened to your vehicle, route the control cable to your transceiver. Any 150 watt PEP transceiver may be used. (For connections, refer to the SG-235 manual).

8. Refer to the QMS system illustration for dimensions and mounting details.

When you are confident that items 1 through 8 have been thoroughly checked, you are ready to install the tip of the SG-303 antenna. Be sure to secure all items with the appropriate tool and to read all product manuals prior to installation or operation.





Warning: If you do not properly and securely attach this unit to the vehicle, the speed of the vehicle may cause it to come loose causing the unit to injure others.

General Installation Information

The mobile communication tips found below apply to any mobile installation, not merely to the QMS or other SGC product.

- For the best performance and radiation, always mount your antenna system on the highest part of the vehicle. Approximately 3 to 15 dB in radiation performance may be gained in simply re-positioning your antenna system from a low to a high point.
- Never use your antenna system while the antenna is reclining against the body or the roof of the vehicle. In this situation, you may find your antenna system performance varies from 6 to 15dB making it difficult or impossible for your coupler to find a proper tuning position.

Additional Installation Suggestions

Suction cups and straps both secure the installation and ease its removal.

Suction Cups.

Protecting Painted Surfaces: When applying the high suction devices incorporated into the QMS, it is important to observe two important rules:

- Surfaces must be cleaned prior to installation to prevent scratching.
- Surfaces must be protected during removal to prevent marring.

Eliminating Damage to Painted Surfaces: The suction cups on your QMS are of extremely high quality. They will provide excellent service for many years provided you follow certain

basic cautions when using them:

- When you are applying the suction cups, prepare the surface by cleaning with mild detergent and rinsing thoroughly. The clean surface, free of scratches, will provide superior holding power.
- If the QMS being applied has been used previously, clean the suction cups with mild detergent and water, then rinse thoroughly.
- Spread a thin layer of silicon grease or pharmaceutical grade lubricant such as “Vaseline” around the edge of the suction cup where it comes in contact with the surface of the vehicle. The lubricant will prevent slow leakage of air, which will reduce the holding power of the suction cups over time. It will also protect the painted surface.

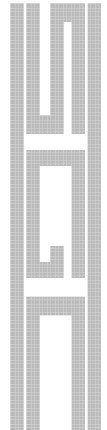
Even if the surface of the vehicle is rough, the installation procedure remains the same. The suction cup will have to be pressed against the vehicle surface in the same way, but more lubricant may be necessary.

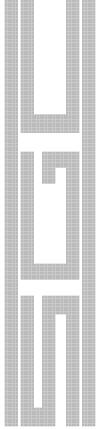
QMS Straps. The QMS enclosure must be tightly strapped to the vehicle. To ensure it is properly strapped, grab the base of the antenna mounted on the QMS and push firmly up and down. The vehicle should move up and down, but the QMS should not. If the QMS moves and the vehicle does not, increase the tension on the QMS straps.

Caution: In no case should the operator use fewer than the four straps provided to secure the unit. The suction cups alone will not provide sufficient mounting for the QMS.

Removing the QMS. Wash the vehicle in the area around the suction cups before removing. This will reduce any chance of surface marring.

- Release suction by applying a rolling sideways motion to the tabs on the suction cups as shown in the following drawing:





- To make removal of the unit easier, you may slide a piece of paper be-between the suction cup and the vehicle surface In this way, each of the suction cup tabs may be loosened sequentially as shown:

Storing Your QMS. To store your QMS unit for long periods of time, apply a thin coating of talcum powder to the suction cups. This treatment increases the life span of rubber products.

Appendix B

Selection of Equipment for Go Mobile 500 Watts

SGC has assembled several packages of equipment to make it easier for you to Go Mobile.

HF Radio System. This complete installation includes the SG2000 slimpak transceiver with PowerTalk remote head (with mount), the SG-500 SmartCube linear amplifier, and an SG-235 antenna coupler mounted in a quick-mount (QMS) with SG-303 whip antenna.

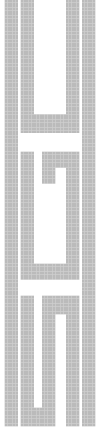
500-Watt Package. For the operator who wants to use a currently-installed transmitter, this package provides the SG-500 SmartCube linear amplifier and an SG-235 antenna coupler mounted in a quick-mount (QMS) with SG-303 whip antenna.

500-watt Coupler. Go Mobile with the transceiver and amplifier you already own: this package provides an SG-235 antenna coupler mounted in a quick-mount (QMS) with SG-303 whip antenna.

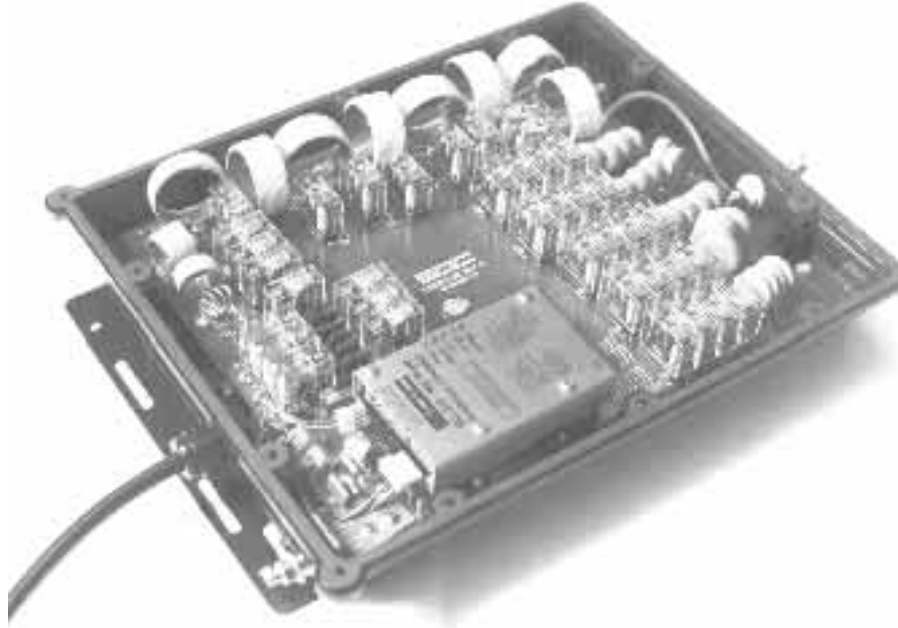
150-watt Coupler. Go Mobile with the 150-watt transceiver you already own: this package provides an SG-235 antenna coupler mounted in a quick-mount (QMS) with SG-303 whip antenna.

Choose the package that's best for you:

Package	QMS-2 w/ SG-230	QMS-3 w/ SG-235	SG-500	SG-303	SG-2000 Power Talk
HF Radio System		✓	✓	✓	✓
500-Watt Package		✓	✓	✓	
500-watt Coupler		✓		✓	
150-watt Coupler	✓				



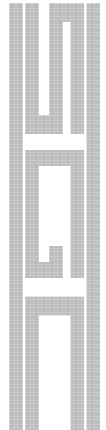
SG-235 500 watt Smartuner



Specifications

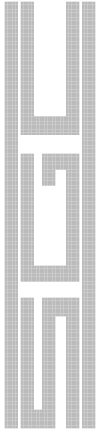
HF Frequency Ranges	1.8 to 30MHz	Antenna Length:	Min. length 23 ft., 3.5 to 30 MHz Min. length 50 ft., 1.8 to 30 MHz
Power Input Range:	3 to 500 watts (PEP)	Operating Temperature:	-35° to +70°C
Input Impedance Range:	45 to 55 ohms	Environmental:	Waterproof at immersion of half meter, half hour
VSWR:	Typical—less than 2:1	Size Overall:	16 D x 12 W x 3H inches 40.6DS x 30.5W x 7.6H centimeters
DC Input Requirement:	+13.6VDC	Weight:	8 pounds (3.5 kilos)
DC Operating Range:	+10.5 to 15 VDC	Case Construction:	Plastic ABS weatherproof case
Input Current:	Average—.9 amps	Cable:	SGC special cable, 9 feet coaxial and two power wire input wires, RMT tune and Smartlock wire
Random Set Times:	Typical—less than 2 seconds	Installation:	Any position
Recurrent Set Times:	Typical— less than 10 milliseconds		
Non-volatile Memory Addresses:	500		

SG-500 SmartPowerCube



Specifications

Power Output:	SSB: 500 W PEP CW: 500 W 10 Min. (No Fan) 500 W Unlimited w/fan (at 50% duty cycle) AM: 250 W carrier max.	Keying:	Via PTT line
Frequency Range:	1.6 - 24 MHz	Built In Test Equip:	Microprocessor controlled LED display of faults
Power Input:	50 - 90 watts (Automatic or preset) 90 - 150 watts	Modes Supported:	SSB, CW, RTTY, SITOR, ALE, SSTV, AM at 250 W
Band Switching	Manual	Protection:	Input overdrive Under voltage (adjustable) Factory default 10.0 VDC Beyond Frequency Limits Amplifier module current imbalance Excess current draw High temperature Antenna fault
Input Voltage:	14.0 VDC	Color:	Matte black
Input Voltage Range:	10.0 - 18.0 VDC	Case:	Special metal casting
Input Current:	40 Amps average (SSB) 90 Amps Peak	Weight:	21 Pounds (9.5 Kg)
Cooling:	Convection standard Optional: Cooling Fan	Dimensions:	4.9" H x 12.0" D x 10.8" W Fan changes H to 9.75" 6.1" H x 13.2" D x 10.8" W w/feet
T/R Switching Time:	10ms. nominal		

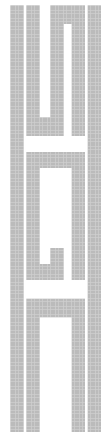


Appendix C

Mobile System Test Results GEO Metro

Frequency in KHz		Forward Power	Reflected Power	Voice
3700	Exciter LO	26	1	5
	Exciter HI	50	1	5
	Amp LO	270	2	5
	Amp HI	440	39	5
7200	Exciter LO	27	1	5
	Exciter HI	50	2	5
	Amp LO	300	14	5
	Amp HI	520	24	5
10150	Exciter LO	30	0.5	
	Exciter HI	50	1	
	Amp LO	460	30	
	Amp HI	540	40	
14300	Exciter LO	28	0.5	5
	Exciter HI	52	0.5	5
	Amp LO	440	6	5
	Amp HI	560	8	5
18150	Exciter LO	31	1	5
	Exciter HI	56	1.5	5
	Amp LO	460	8	4
	Amp Hi	500	8	4
21200	Exciter LO	30	2	5
	Exciter HI	55	3.5	5
	Amp LO	520	26	5
	Amp HI	560	28	5
24825	Exciter LO	34	2	5
	Exciter HI	60	3	5
	Amp LO	580	20	5
	Amp HI	620	14	5
28500	Exciter LO	28	3	5
	Exciter HI	52	5.5	5
	Amp LO	520	34	5
	Amp HI	560	36	5

System voltage measured at amplifier terminals: 14.2V
in standby mode, 12.9V in transmit mode on 28MHz band



Suggested Retail Price
U.S. \$19.95

IT ALL ADDS UP

Essential Components from SGC



SG-2000 *HF* radio
(or any other *HF* rig)



SGC PowerCube
500W linear amplifier



QMS-3 with SG-235
antenna coupler

= Go MOBILE
at 500 watts with SGC Significant Components



1-800-259-7331

The SGC Building
PO Box 3526, 13737 S.E. 26th Street, Bellevue, Washington 98009 USA
Telephone: 425-746-6310 Fax: 425-746-6384
E-mail: SGCMKTG@aol.com Website: <http://www.sgcworld.com>

© 1997 SGC, Inc.