

User Manual

Solid-State 144MHz Band
500W Linear Power Amplifier

Model HL-500V



1. HL-500V FEATURES

- HL-500V is a solid-state VHF/144MHz band linear power amplifier with the maximum output power of 500W. Switching type AC to DC power supply is built in. It is great for 2m DX communications as well as EME QSO.
- AC voltage is automatically selected between AC 100V and 240V. No rewiring of AC primary voltage is required, if you change operating AC line voltage. Only the AC plug change is needed to fit your particular operating location.
- A pair of the latest RF MOS FET , MRF151G's , designed by Motorola, are used at the power amp stage to achieve a stable output of 500W max. Broad band design has eliminated the troublesome tuning operation as is needed with a tube type linear amplifier. Turn the AC power switch and you will be on the air. With the duct structure for cooling air flow, an ideal cooling effect has been achieved.
- RF key circuitry is built in. When the RF driving power is detected, the amp will be automatically keyed. Also the STBY (stand-by) terminal is located at the rear panel with which the amp is keyed through the radio.
- Various protection circuits have been built in such as power supply, antenna, RF power amp board etc. for the safety.
- A large analog meter monitors the forward and reflected power always.

2. CAUTION

- There are high voltages running inside the cabinet, such as AC100V, 200V, DC50V etc. High RF voltage is also generated during the transmission. Do not open the top cover carelessly.
- Rugged antenna with good SWR (1.5 or less) must be used to withstand 500W continuous power.
- Do not exceed driving power of 20W (and/or 50W, if selected so).

3. SPECIFICATIONS

Frequency	:	VHF 2m Band (144 ~ 148 MHz Amateur Band)
Mode	:	SSB , CW , FM
RF Drive Power	:	20W and/or 50W (Switch selectable)
RF Output Power	:	500W
In/Out Impedance (Zin/out)	:	50 ohms (unbalanced)
Final RF Power Transistor	:	MRF151G x 2 (by Motorola, M/A COM.)
Amp. Circuitry	:	Class AB Parallel Push-pull
Accessory Circuits	:	Meterings for Pf & Pr RF key circuit (Carrier operated send/receive switch) Protection circuits for antenna open/short, over current/Idc, PA unbalance, over drive, over heat)
AC Power	:	AC 100V ~ 240V (Auto select) , 1.2kVA max.
In / Out connectors	:	Type N
Dimensions	:	345 x 145 x 390 mm (WxHxD)
Weight	:	Approx. 12 kgs. (26.5 lbs.)
Accessory Parts	:	Coax Jumper Cable (69 cm) x 1 RCA plug x 2 Spare fuses 25A x 1 , 2A x 1 AC power cord x 1
Cooling Method	:	Forced Air with Book Fan

4. Front and Rear Panels



FRONT PANEL

POWER : This is a power switch to turn on and off AC main power. At off position, the signals to and from the antenna will bypass the linear amplifier.

OPER. /STBY : At OPER. Position, T/R switching circuit is turned on and the amplifier will become ready to work.

At STBY, the amplifier will be on stand-by mode, and amplifier will be at through state.

METER Pf / Pr : As this switch is pushed, meter scales of “Output power” (Pf) and “Reflected Power” (Pr) are changed.

DRIVE 50W/20W : This switch will select the driving power from the transceiver i.e. 50W or 20W. Pushing the switch, LED lamp of either 50W or 20W will light reciprocally.

MODE SSB / FM : This switch changes the time lag from TX to RX , when using RF key circuit. At FM, TX to RX switching is made instantly. At SSB, time lag will be approx. one second. For CW operation using RF key, set this switch at SSB.

LED Lamps :

Pf / Pr : Lamps will light as the METER switch is pushed to either Pf or

Pr.

Drive Power : Lamp of corresponding power level of either 50W or 20W will light.

PROT (Protection) : There are protection circuits for “Over drive “, “Reflected power from antenna “, “Over heat (inside of amp.) ”, “PA over current “, and “ Unbalance of PA units “. When either one of these works, PROT LED will light indicating that protection circuit has shut down the amplifier. Turn off the POWER switch and turn on again to reset the protection. LED will go off.

SSB / FM Mode : Lamp will light as either FM or SSB is selected.

TX : LED will light when the amplifier is transmitting.

OPER. : Lamp will light when OPER/STBY switch is turned on.

METER : Meter will read each power of to and from the antenna , Pf and Pr.

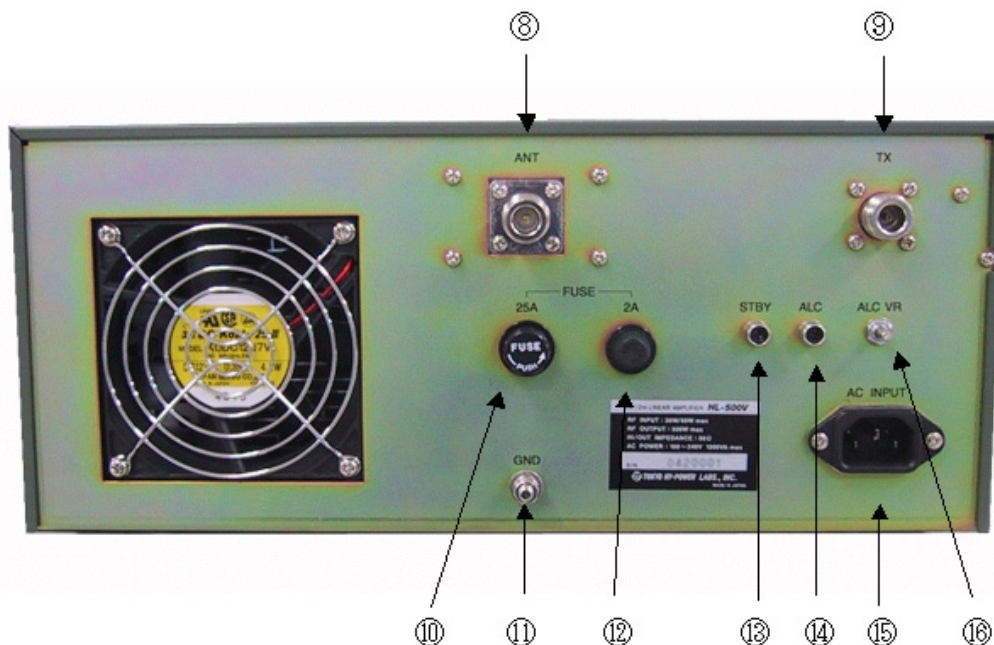

Rear Panel

ANT : N connector. Connect the cable from the antenna. The antenna must have a

power handling capability of 500W (continuous) minimum.

TX : RF input N connector. Connect to the radio with the supplied coax jumper cable.

FUSE 25A : 25A fuse holder for final amp unit. (This is not a fuse for AC power line.)

GND : Ground terminal.

FUSE 2A : 2A fuse holder for power supply of control circuit.

- STBY** : The terminal to be grounded through ACC and/or REMOTE terminal (or called “SEND” , “ TX GND “ depending on the radio manufacturer) of the radio to key this linear amp. **NOTE :** **WHEN USING THIS, TERMINAL, BE SURE TO REMOVE THE JUMPER PLUG , J14 ON THE CONTROL CIRCUIT BOARD** (See following page.) For RF keying, do not remove this plug. Connecting STBY terminal to the radio, TX/RX switching will be very smooth for ssb and cw modes.
- ALC** : ALC jack. Connect to external ALC input pin of the radio. See the radio manual. With this connection, output power will be maintained at certain level even if the amp is over driven by the radio. (Note : ALC connection is not necessarily required for modern well controlled radio.)
- AC INPUT** : Connect the supplied AC cord here. The internal AC to DC power supply will automatically select 110/115/120V and 220/230/240V. You will not have to change or select any of AC primary voltage.
- ALC VR** : Potentiometer to adjust ALC output level of negative DC voltage. When the ALC cable is connected to the radio (see above), turn this potentiometer counter clock wise, and output power of the linear amp will start to decrease. (See the manual of the radio for the proper external ALC voltage level. Variable DC voltage of 0 to negative 9V is available at this jack for 500W is produced.)

5. Connection

Referring to the illustration at page 8, confirm if all the connections are made correctly.

Turn on the power of the transceiver. Keep the power switch of this linear amp at OFF position. Also set OPER./STBY switch at STBY position.

On reception, signals from the antenna pass through the linear amp and received signals will be heard from the radio.

Check the SWR of your antenna system choosing the frequency channel not occupied with other stations. SWR must be made relatively low , 1.5 or lower if it is too high.

Turn on the power switch of the linear amp.

Push the drive power level switch to select the proper level of either 20W or 50W in accordance with your radio.

Push the MODE switch to select either SSB or FM. When the STBY terminal is connected to Remote or ACC terminal pin of the radio, please select “FM” rather than SSB. And TX to RX switching will be made with no time lag that will make smoother SSB communication.

Turn the OPER./STBY switch to OPER. position. If you key the transceiver, this amplifier will also be keyed with either rf key or hard key of the radio. Amplified high power signal will be emitted from the antenna. Power meter will be deflected according to the transmitting power (Pr), and will indicate the reflected power as well (Pr) if the meter switch is turned to Pr. Pr (reflected power) may increase depending on the power handling capacity of the antenna.

If you are going to run the radio without a linear amplifier (on barefoot), please turn the power switch off , leaving all the cables connected as they are. (Or you may simply turn the OPER./STBY switch to STBY position, and signals to and from the radio will bypass the linear amplifier.)

6. About The Protection

This linear amplifier has four protection functions as follows. If the limit of the certain parameters are exceeded, protection circuit will shut the amplifier for the safety and PROT LED will light..

6-1. Temperature

When the internal temperature of the cabinet reaches 40 deg. C, the cooling fan starts to work. Furthermore “PROT” LED lamp lights when it reaches 90 deg C.

(Solution : Wait for a while at stand by mode until PROT lamp goes off.)

6-2. Over Drive Protection

If the driving power from the radio exceeds the rated input power of either 20W or 50W (or approximately 120% of rating), “PROT” LED will light.

(Solution : Check the output of your radio. Even if the high power radio is adjusted for lower output of 20W, it may **emit high output momentarily**, when keyed. This causes the over drive.)

6-3. Reflected Power Protection (Pr)

When the reflected power from the antenna reaches 50W, “PROT” LED will light.

(Solution : Check the antenna for SWR and maximum power rating as well.)

6-4. Over Current Protection

When the total DC current flowing into the MRF151G's , MOS power FET, exceeds the rating of 22A, “PROT” LED will light. If the antenna SWR is relatively high, total drain current of power amp will vary according to the condition.

(Solution : Check the antenna SWR.)

** When the “PROT” has worked, turn off the POWER switch once to correct the possible causes.

If the POWER switch is turned on again, PROT will be reset and LED lamp will go off.

**

When the “STBY ” is going to be connected to the radio, jumper plug J14 must be pulled off the control pc board as shown in the following illustration. Be sure to pull the AC Main power plug off the wall and remove the top cover of the amp to locate J14.

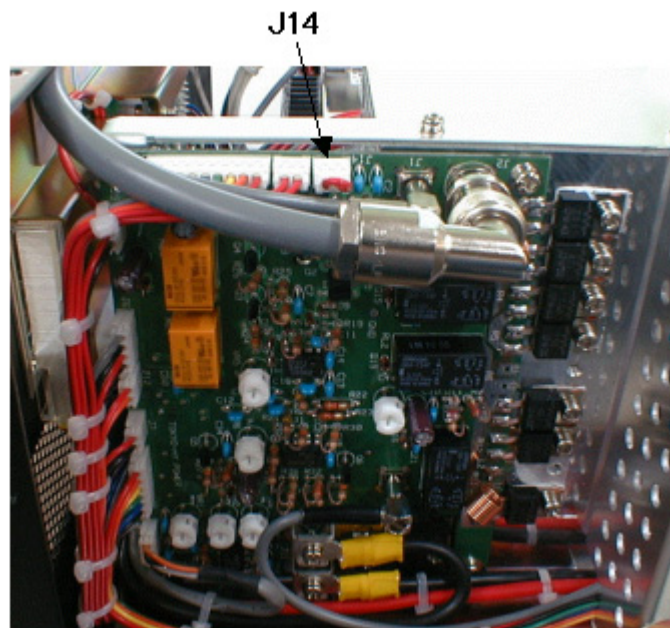

**** CONNECTION**

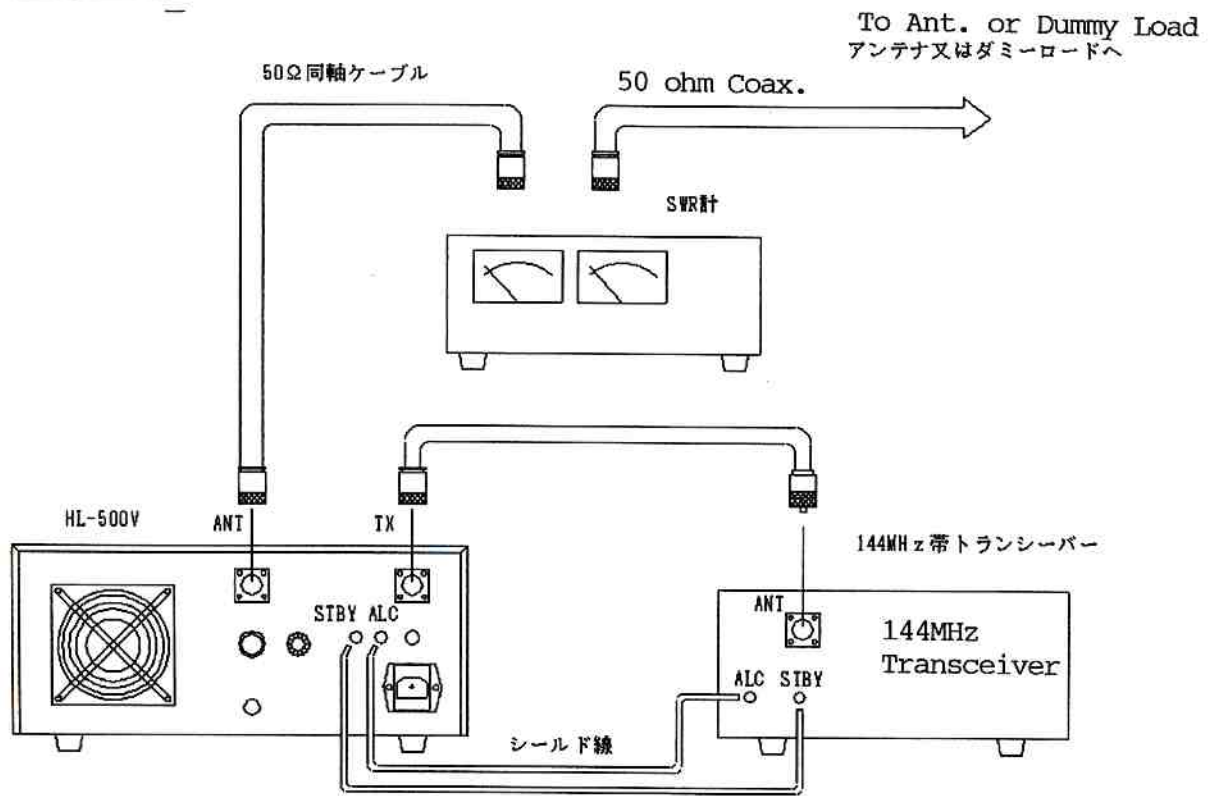

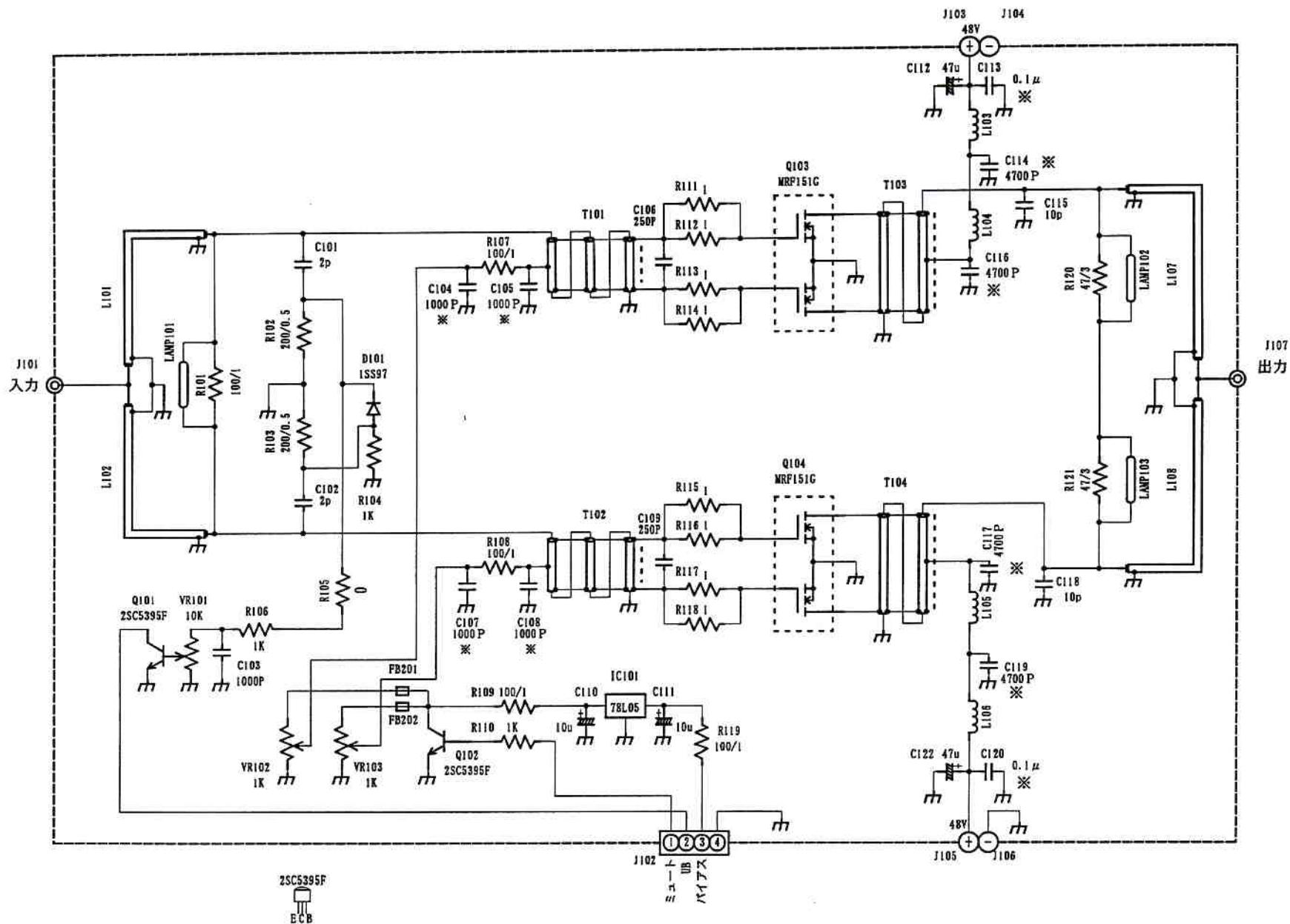

※ チップコン

指定外公差 一般 +/-				単位: mm	材質	名称	個数
承認	検図	製図	設計	第三角法	処理	PAユニット	
		浜島		尺度 1/1	THP	品番	図番 PC1636

216.8.17.

2SC5289F
2SA1893

入力力: 15Wで入るように
Pr: Pr=50Wで入るように
通電線: 10Aで入るように
起電時間: ①で25ms②より遅れるように

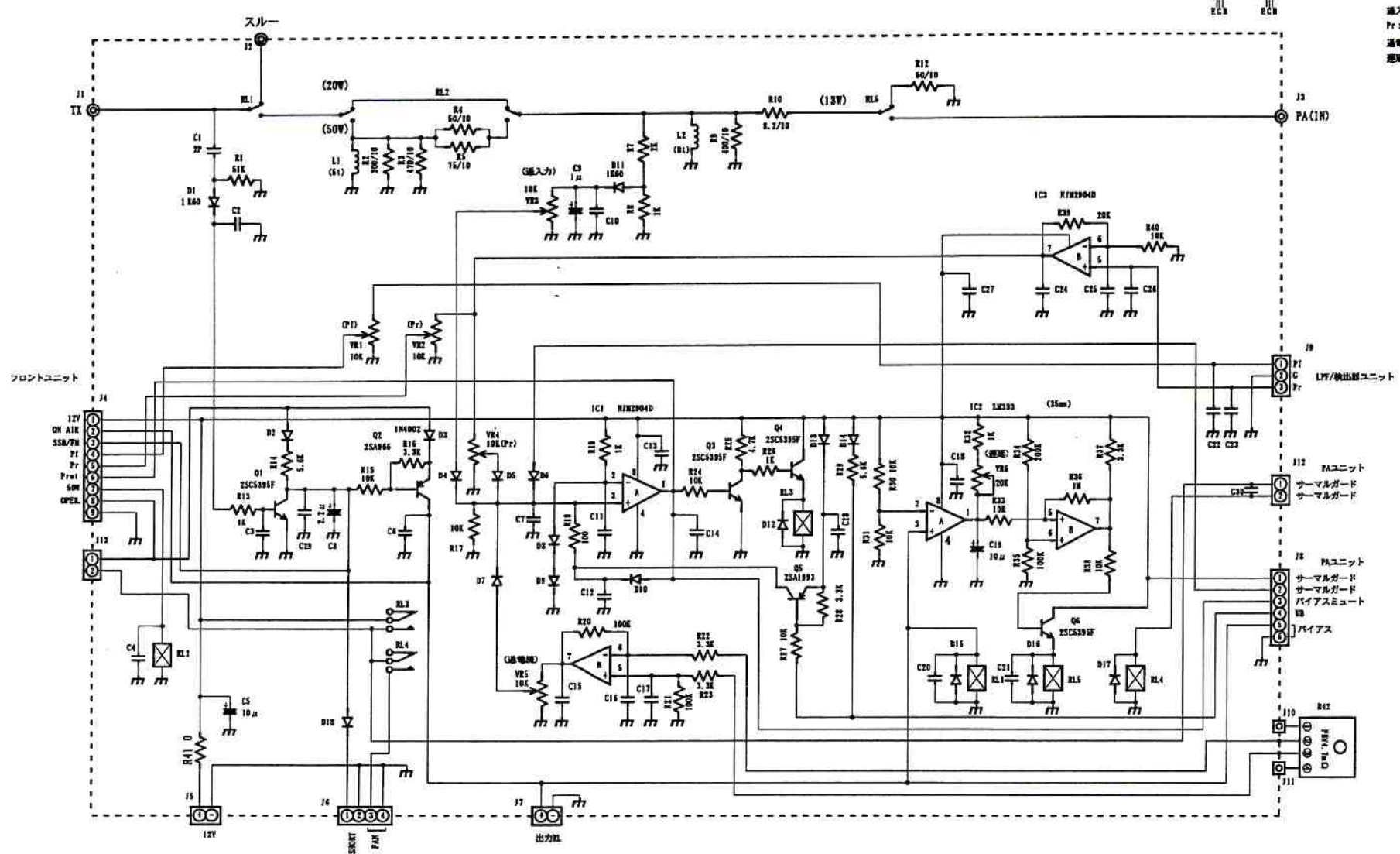

RL1.2.5 G6A-234P DC12V
RL3.4 DSI DC12V
指定ないコンデンサ50V1000PF

" Controller Board "

指定外公差 一般 +/-				単位: mm	材質	名称	個数	
承認	検図	製図	設計	第三角法	処理			
		浜島	浜島	尺	THP	品番	PC1641	
				度	型名			L1322VI
							図番	

コントロール基板

THP 型名 L1322VI

品番 図番 PC1641

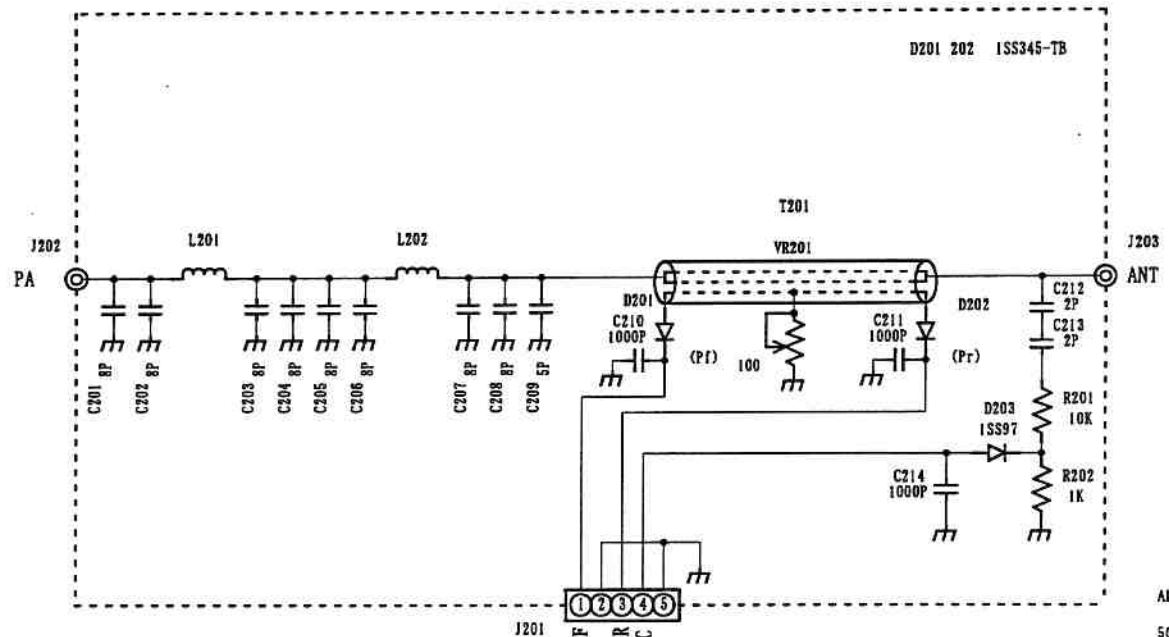

ALC 500Wのとき約-12V
500Wの時PF=5.88V Pr=0.35V

コントロールユニット

指定外公差 一般 +/-				単位: mm	材質	名称	LPF/検出器ユニット	個数
承認	検図	製図	設計	第三角法	処理			
		浜島		尺度 1/1	THP	型名	L1322VI	図番
						品番		PC1642

5D-2V JP11

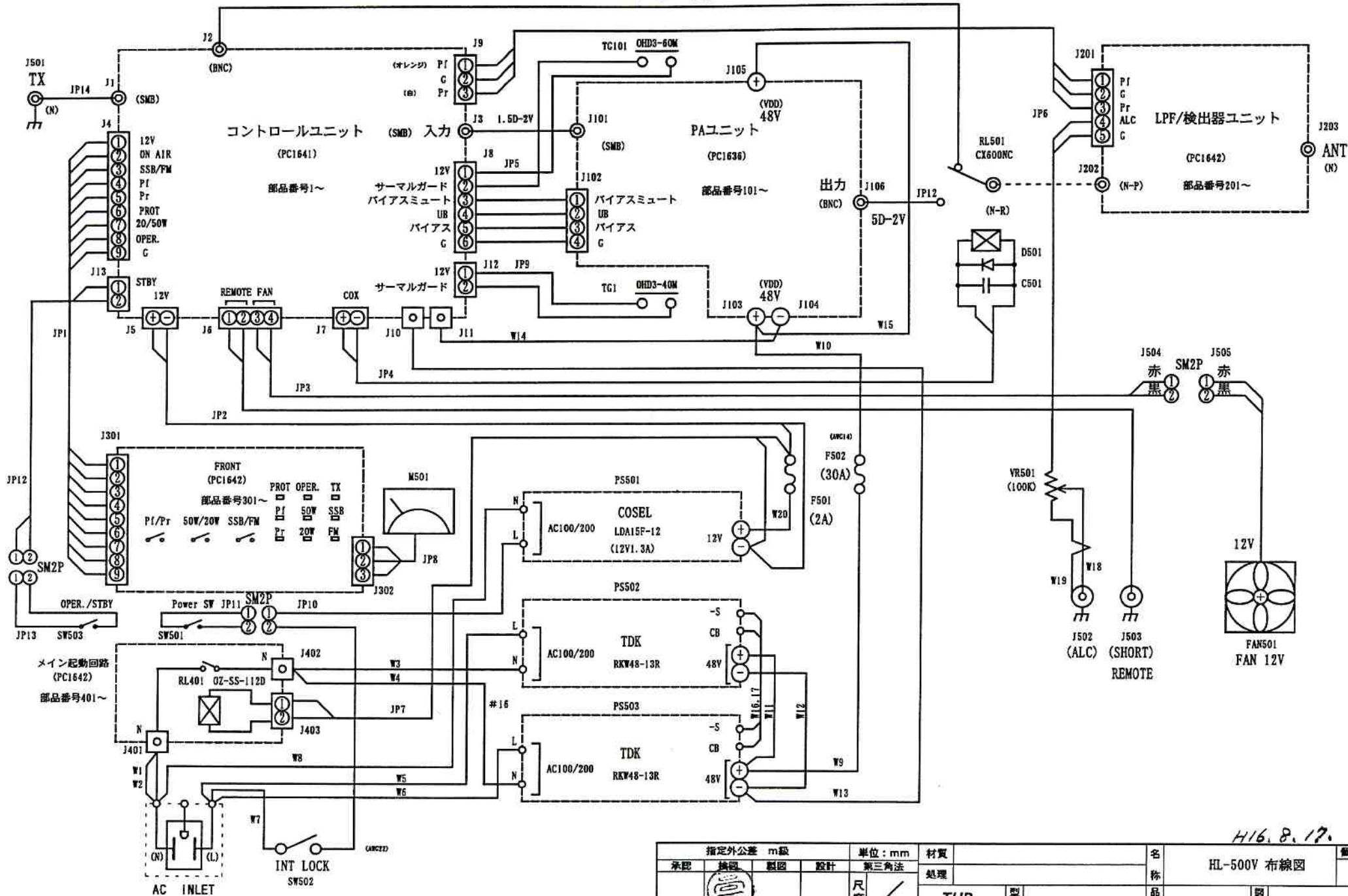

H16.8.17.

指定公差 m級				単位: mm	材質	名称	個数
承認	検閲	製図	設計	第三角法	処理		
				尺度 /	THP	品番	
						型名	
						図番	

HL-500V 布線図