



HF RADIO COMMUNICATIONS

3040 Automatic Whip Antenna



Installation Handbook

No part of this handbook may be reproduced, transcribed, translated into any language or transmitted in any form whatsoever without the prior written consent of Codan Limited.

© Copyright 2010 Codan Limited.

Codan part number 15-04166-EN Issue 1, June 2010.

Brand, product, and company names mentioned in this document are trademarks or registered trademarks of their respective holders.

The English version takes precedence over any translated versions.

Introduction

1 Overview

General	4
Care and safety instructions	5
Connectors	6

2 Installing the antenna

Disclaimer	10
What you need to consider	10
Installing a 3040 Automatic Whip Antenna	18
Installing an NVIS kit with a 3040 Automatic Whip Antenna	21

3 Specifications

General	23
Mechanical	24
Environmental	25

4 Accessories

Appendix A—Compliance

Introduction	30
European R&TTE Directive	30
EMC and safety notices	31
FCC compliance	33
Register of hazardous substances	34

Appendix B—Definitions

Standards and icons	37
Acronyms and abbreviations	38
Units	39
Unit multipliers	40
About this issue	40

Index

List of figures

Figure 1:	3040 Automatic Whip Antenna	4
Figure 2:	Connectors on the antenna tuner	6
Figure 3:	Front view of the antenna control connector	7
Figure 4:	Mounting footprint	12
Figure 5:	Rear-mount location on sedan vehicle	13
Figure 6:	Rear-mount location on off-road vehicle	14
Figure 7:	Front-mount location on off-road vehicle	14
Figure 8:	3040 antenna with NVIS kit	21

List of tables

Table 1:	Pinouts for the antenna control connector	7
Table 2:	3040 to NGT connections	19
Table 3:	General specifications	23
Table 4:	Mechanical specifications	24
Table 5:	Environmental specifications	25
Table 6:	Accessories for the 3040 Automatic Whip Antenna	27
Table 7:	有毒有害物质列表 (Register of hazardous substances).	34

This handbook is for installers of the 3040 Automatic Whip Antenna. It assumes that you have experience in installing antennas.

This handbook contains the following sections:

- Section 1** **Overview**—provides an overview of the antenna, connectors, and general information
- Section 2** **Installing the antenna**—provides guidance on how to position, install, and earth the antenna
- Section 3** **Specifications**—provides the common operational, environmental, and physical specifications of the antenna
- Section 4** **Accessories**—lists the accessories available for the antenna
- Appendix A** **Compliance**—provides compliance information and safety notices for your antenna
- Appendix B** **Definitions**—explains the terms and abbreviations used in this handbook

There is an index at the end of this handbook.

This page has been left blank intentionally.

1 Overview



This section contains the following topics:

[General \(4\)](#)

[Care and safety instructions \(5\)](#)

[Connectors \(6\)](#)

General

The 3040 Automatic Whip Antenna is designed to provide continuous tuning for vehicle-mounted transceivers that scan multiple frequencies. It is designed to withstand extreme environmental and physical conditions. When tuning, the antenna seeks the optimum tuning point, ensuring that the best communications possible are achieved.

The 3040 Automatic Whip Antenna comprises:

- a 1.6 m (62 in) fibreglass or stainless steel whip
- an 865 mm (34.0 in) riser
- a spring
- an antenna tuner with connectors, base plate and earth wire

Figure 1: 3040 Automatic Whip Antenna

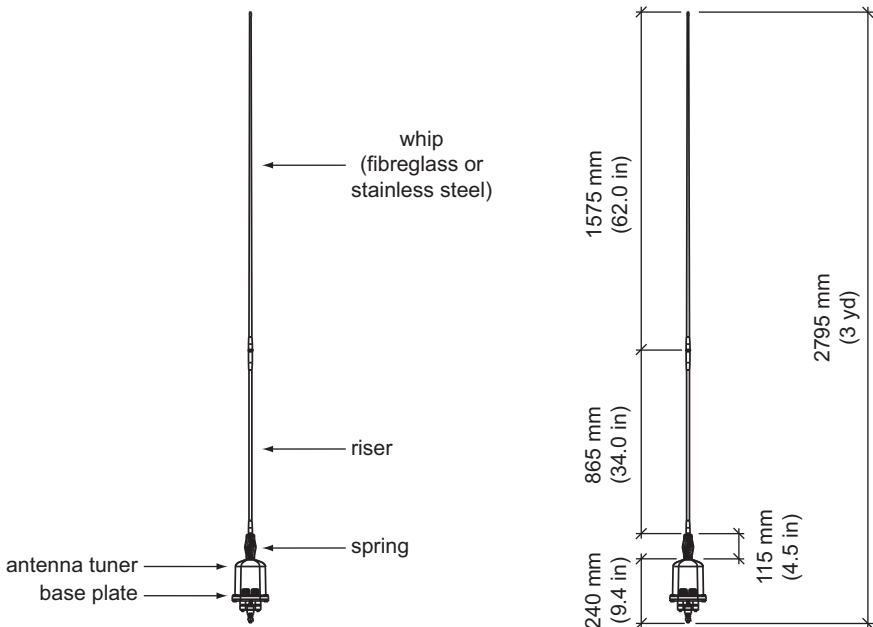

Care and safety instructions

You should unscrew the whip and riser from the antenna base when the antenna is not in use.

When travelling in scrub or undergrowth, avoid overhanging branches.

Connectors

There are two connectors at the base of the antenna as shown in [Figure 2](#).

Figure 2: Connectors on the antenna tuner

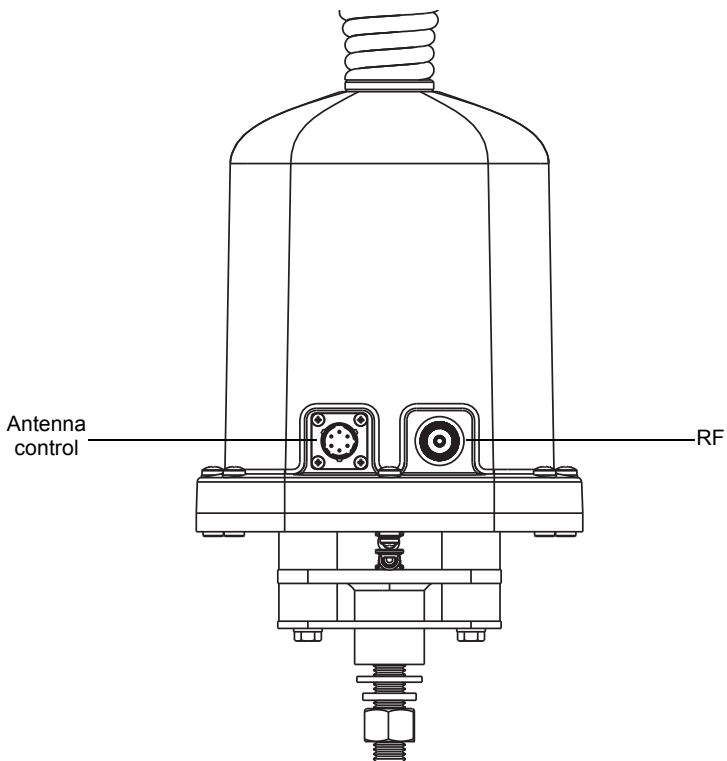

Figure 3: Front view of the antenna control connector

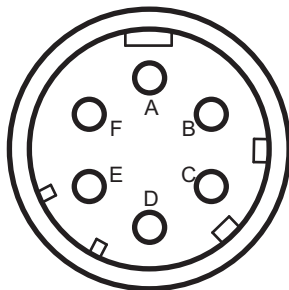

Table 1: Pinouts for the antenna control connector

Pin no.	Description
A	+12 V DC
B	Earth
C	Tune
D	Scan
E	Tune status indicator
F	Not used

This page has been left blank intentionally.

2 Installing the antenna



This section contains the following topics:

[Disclaimer \(10\)](#)

[What you need to consider \(10\)](#)

[Installing a 3040 Automatic Whip Antenna \(18\)](#)

[Installing an NVIS kit with a 3040 Automatic Whip Antenna \(21\)](#)

Disclaimer

WARNING The antenna should be installed by a suitably-qualified technician, to the relevant standards and approvals.

WARNING While the following instructions are intended to assist with installation, it is the purchaser's responsibility to ensure that the antenna is installed with due regard to pedestrian and vehicle-occupant safety, particularly in the event of a vehicle accident. Codan accepts no responsibility or liability in the event of injury to pedestrians or vehicle occupants or any other damage due to insecure or otherwise unsafe or inappropriate installation of the antenna.

What you need to consider

The antenna is a critical element in an HF communications system. Correct installation of the antenna provides efficient operation over the frequency range of the transceiver. A good installation ensures the antenna provides optimum output power during transmission and clear reception of weak signals.

When installing the antenna you must consider:

- the location and mounting of the antenna
- how to provide a good earth plane for the antenna
- the routing of the coaxial and control cable

Location

To obtain optimal radiation efficiency from your antenna, and optimal reception at your antenna, it must be mounted in a location that:

- is clear of surrounding body work
- supports a good earth plane
- supports the RF earthing required for correct tuning and loading
- allows for best radiation (open and clear of all metal obstructions)

When mounted, the antenna:

- must not obscure the driver's vision
- must not obscure number plates or vehicle lights
- should not interfere with engine or car openings
- must clear electric power lines, overhanging trees, bridges etc
- must not breach vehicle-licensing regulations

A mounted antenna must have:

- a strong anchorage for the base of the antenna
- a sound electrical connection to the vehicle chassis

The mounting footprint in [Figure 4 on page 12](#) shows the required space for the base of the antenna tuner.

Figure 4: Mounting footprint

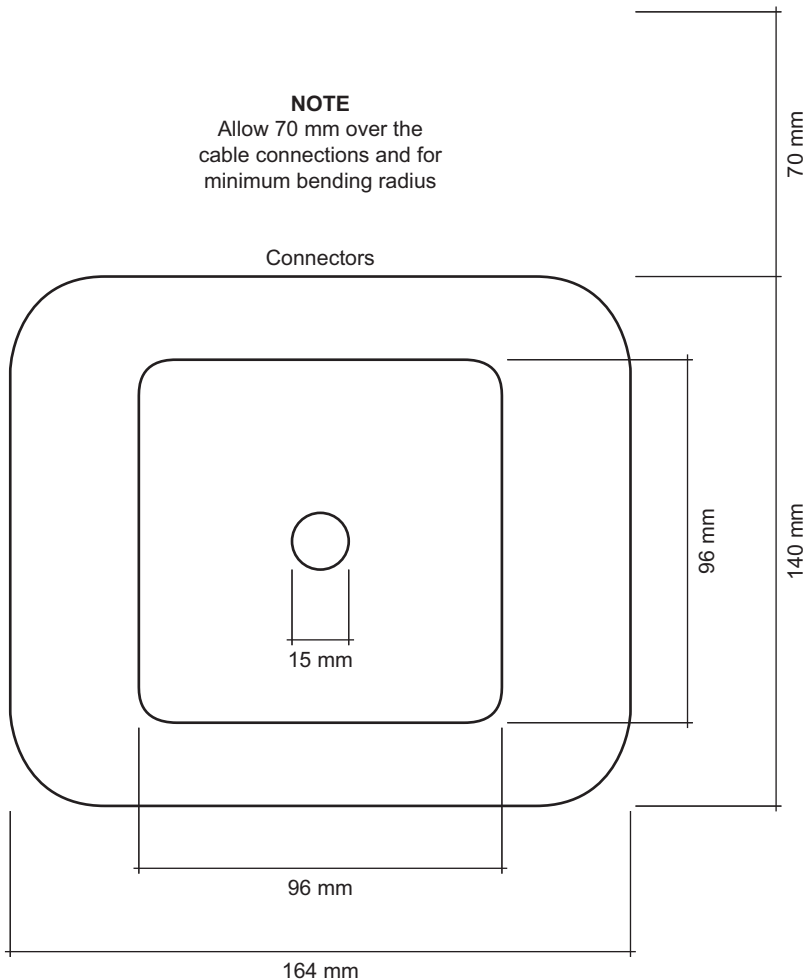

Possible mounting locations that provide good electrical performance of the 3040 Automatic Whip Antenna are shown in the following photographs.

Figure 5: Rear-mount location on sedan vehicle



Figure 6: Rear-mount location on off-road vehicle



Figure 7: Front-mount location on off-road vehicle



CAUTION If the antenna is front-mounted, it should be mounted on the side opposite to the driving position.

Mounting bracket

The antenna must be mounted on a sturdy metal plate (at least 8 mm (0.3 in) thick). The mounting bracket and fixing should be able to withstand any vibrations induced from the vehicle travelling over an off-road surface. A strong metal plate that is large enough to support the antenna will also provide efficient earthing. The plate must have a 15 mm (0.6 in) hole to accept the mounting screw.

NOTE You should consider any overall height restrictions that are relevant to your vehicle.

The bracket should be located so that any flexing of the antenna assembly does not damage the panels of the vehicle.

The installed antenna should enable easy access to the connectors.

Earthing

Most mobile antennas are considerably shorter than a quarter wavelength at HF, and can exhibit an extremely low radiation resistance. Consequently, their efficiency is reduced compared with the quarter-wave radiator that they represent. This can be improved by good installation practices, and most importantly, by the provision of a low-impedance earth return for the antenna.

Due to the relatively poor earth plane surrounding a mobile HF antenna, best use should be made of what is available. A reduction in any losses can increase antenna current and radiation. This can often be achieved by providing a good earth connection from the base of the antenna to nearby bodywork. An earth wire is provided for this. Connections to the vehicle chassis are not as effective because many 4WD vehicles have insulating mountings from body to chassis.

A strong metal plate that is large enough to support the antenna will provide efficient earthing. The plate should be welded to the chassis or some other part of the vehicle's frame.

The mounting bracket and plate must be free of rust and paint to allow metal-to-metal contact between the base of the antenna and the mounting bracket. This electrical bond is the basis for effective RF earthing. RF currents flow on the conductor surface, therefore good RF earthing requires conductors with large surface areas.

NOTE Conductive grease should be used on the touching surfaces to help prevent corrosion.

The RF earth differs from the DC earth required by the battery and the vehicle's electrics. For more information on power supply factors and earthing the transceiver, see the documentation provided with the transceiver.

Cabling

The coaxial cable between the antenna and the transceiver should be installed as far as possible from other vehicle wiring, especially high-tension ignition wiring or the engine management computer.

The cabling must be in a position that:

- is away from the driver's feet
- is secured and concealed as much as possible
- is secured behind protective metalwork (only if the cables run under the vehicle)

Keep cables in the engine compartment away from:

- heat, for example, exhaust, air-conditioning systems, and water pipes
- oils and corrosive liquids, for example, engine oil, battery fluid, and brake fluid

Protect all the cables from sharp edges and mechanical abrasions. Cables that pass through body panels or internal bulkheads must be protected by rubber grommets. Holes in the bulkhead need only be large enough to allow the end of the cable with the smaller connector to pass through. Removing a connector should be a last resort.

CAUTION Removal of factory-fitted connectors may cause cable or connector faults.

CAUTION Crimp-style coaxial connectors are not suitable for vehicle installations because they are not weatherproof.

NOTE Any cabling under carpet or floor mats should be clear of foot traffic.

Installing a 3040 Automatic Whip Antenna

To install the antenna on a vehicle:

- Attach the mounting bracket to the vehicle in a manner that complies with the relevant safety standards and approvals.
- Clean the mounting surface of all dirt, rust, and paint.



NOTE Codan recommends that conductive grease is applied to the mounting surface.

- Remove the M14 nut and all washers from the M14 mounting stud at the base of the antenna.
- Insert the mounting stud into the hole on the mounting bracket, then locate the flat washer, spring washer, and nut onto the mounting stud.
- Tighten the nut until the spring washer is compressed.
- Connect an earth wire to a convenient bolt on the bodywork.

NOTE Ensure a good electrical connection is made.

- If you are connecting the antenna to:
 - an NGT Transceiver see the cable connections provided in [Table 2](#)
 - a 2110 Manpack Transceiver see the Fitting Instructions provided with the mounting cradle and or equipment

Table 2: 3040 to NGT connections

Codan part number	Cable type	From connector on antenna tuner...	To lead from RF unit...
08-05627-xxx	Multicore, 6 m (19 ft)	6-way antenna control	
08-01503-xxx	50 Ω coaxial RG58, 6 m (19 ft)	RF	

NOTE

These cables are available in a number of lengths (see [page 27, Accessories](#)).

Do not cut the control or coaxial cable. If the cables are too long, coil the excess neatly and secure it out of the way with cable ties.

WARNING

Do not bunch the control and coaxial cables together.

- Protect any cables passing through metal panels with rubber grommets.
- Tape the connectors on the antenna, and approximately 25 mm (1 in) of each cable, with two layers of self-amalgamating PIB tape (Rotunda 2501) or EPR tape (3M Scotch™ 23).
- Cover the self-amalgamating tape with two layers of high-quality electrical tape (3M Scotch™ 33+, or similar) to minimise aging of the self-amalgamating tape.
- Screw the fibreglass or stainless steel whip to the riser, then screw the riser to the spring.
- Screw the spring onto the antenna stud at the top of the housing of the antenna tuner.

WARNING Do not exert greater than 25 Nm (18 lb-ft) on the stud. Tighten the whip using a spanner with one hand positioned as close as possible to the antenna to minimise any mechanical advantage.

- Test the installed antenna (with connected transceiver) as described in the documentation provided with your transceiver.

NOTE If the length of the antenna is changed, for example, removal of the riser or addition of the NVIS kit, Codan recommends that you manually tune the antenna (press **1**) on each frequency you want to use. This sets the optimum tuning point in the memory of the tuner.

NOTE Troubleshooting for an antenna and how to install a transceiver are provided in the Reference or Operator Manual.

Installing an NVIS kit with a 3040 Automatic Whip Antenna

An NVIS kit (Codan part number 78-14010) is available for attaching to a 3040 antenna. For information on installing this kit with the antenna see the instructions provided with the kit.

The NVIS kit is designed to improve the performance of short to medium-range HF communications for the 3040 antenna by increasing the high-angle radiation characteristics. Typically, these communication distances are 20 to 500 km (12 to 310 mi). The operating frequency range when using the NVIS kit is 2 to 12 MHz.

The vertical radiation pattern from a short vertical whip antenna is very poor. As such, HF communications over short distances may be difficult or non-existent from such an antenna. The NVIS kit lengthens the whip section of the 3040 antenna. The NVIS whip is longer and positioned horizontally to improve the vertical radiation efficiency.

Figure 8: 3040 antenna with NVIS kit

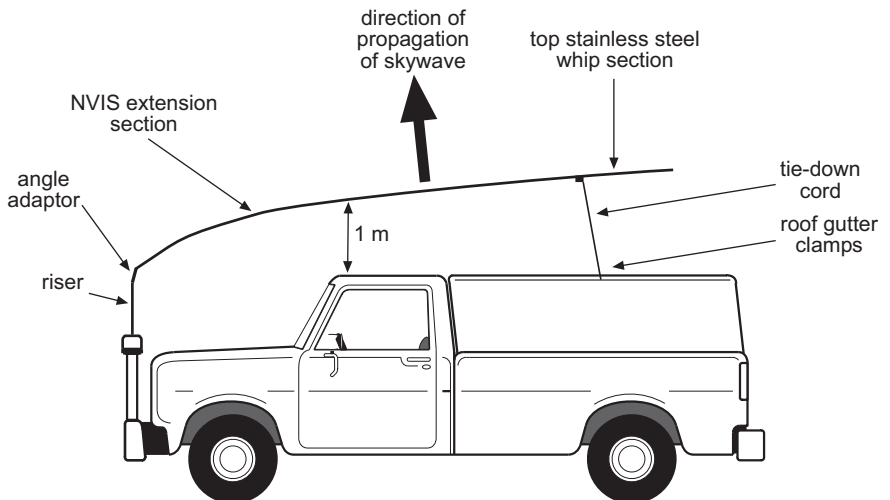

NOTE

When the NVIS kit is added or removed, Codan recommends that you manually tune the antenna (press **1**) on each frequency you want to use. This sets the optimum tuning point in the memory of the tuner.

3 Specifications



General

Table 3: General specifications

Item	Specification
Frequency range	2.5 to 30 MHz (2.4 m whip) 2 to 12 MHz (4 m NVIS)
DC operating range	10 to 15.5 V DC 12 V DC nominal
Power rating	125 W PEP, voice and data
Power consumption	0.4 A, typical < 0.8 A, maximum
Input impedance	50 Ω
VSWR	$\leq 1.5:1$, typical
Tuning speed	1 s average for a new frequency < 150 ms from memory
Memory channels	Unlimited
Connectors	Antenna control: 6-way RF: UHF socket
Cables	Antenna control: Pre-assembled multicore cable available in a number of lengths (see page 27, Accessories) Coaxial: RG58 cable available in a number of lengths (see page 27, Accessories)

Mechanical

Table 4: Mechanical specifications

Item	Specification
Size	Base: 145 mm W × 165 mm D × 240 mm H (5.7 in W × 6.5 in D × 9.4 in H)
	Spring: 115 mm (4.5 in)
	Fibreglass riser: 0.9 m (34.0 in)
	Fibreglass whip: 1.6 m (62.0 in)
	Stainless steel whip: 1.6 m (62.0 in)
	NVIS extension: 1.6 m (62.2 in)
Weight	Base: 3.0 kg (6.6 lb)
	Spring: 0.8 kg (1.7 lb)
	Fibreglass riser: 0.3 kg (0.7 lb)
	Fibreglass whip: 0.3 kg (0.7 lb)
	Stainless steel whip: 0.2 kg (0.5 lb)
	Rigid/bent adaptor: 0.2 kg (0.5 lb)
	NVIS extension: 0.4 kg (1.0 lb)

Table 4: Mechanical specifications (cont.)

Item	Specification
Mounting	M14 stud 40 mm long (1.6 in long)
Colour	Black

Environmental

Table 5: Environmental specifications

Item	Specification
Temperature range	-40 to 70°C
Relative humidity	95%
MIL-STD-810F compliance	Method 512.4: Immersion Method 510.4: Dust Method 514.5: Vibration
MIL-STD-461 compliance	Meets EMC requirements for susceptibilities and emissions

This page has been left blank intentionally.

4 Accessories

Table 6: Accessories for the 3040 Automatic Whip Antenna

Codan part number	Description
08-01503-002	Cable, coaxial, waterproof (2 m)
08-01503-006	Cable, coaxial, waterproof (6 m)
08-01503-008	Cable, coaxial, waterproof (8 m)
08-01503-030	Cable, coaxial, waterproof (30 m)
08-05627-006	Cable, control, NGT-9350 (6 m)
08-05627-008	Cable, control, NGT-9350 (8 m)
08-05627-030	Cable, control, NGT-9350 (30 m)
08-07008-001	Spring
78-14010	NVIS kit
78-18058	Riser, fibreglass
78-23085	Whip, fibreglass
78-23086	Whip, stainless steel

This page has been left blank intentionally.

Appendix A Compliance



This section contains the following topics:

[Introduction \(30\)](#)

[European R&TTE Directive \(30\)](#)

[EMC and safety notices \(31\)](#)

[FCC compliance \(33\)](#)

[Register of hazardous substances \(34\)](#)

Introduction

This section describes how to ensure the 3040 Automatic Whip Antenna complies with the European EMC Directive 89/336/EEC and the European LV Directive 73/23/EEC as called up in the European R&TTE Directive 1999/5/EC.

This section also contains the requirements for FCC compliance.

European R&TTE Directive

The 3040 Automatic Whip Antenna has been tested and complies with the following standards and requirements (articles of the R&TTE Directive):

- Article 3.1b: ETSI EN301489-1 V1.4.1
- Article 3.1b: ETSI EN301489-15 V1.2.1
- Article 3.1a: EN60950-1

Product marking and labelling

Any equipment supplied by Codan that satisfies these requirements is identified by the **CE0191** , **CE0191** or **CE** markings on the model label of the product.

Declaration of Conformity

The CE Declaration of Conformity for the product is listed on [page 40, *Associated documents*](#). This document can be made available upon request to Codan or a Codan-authorized supplier.

EMC and safety notices

Non-ionising radiation safety

To ensure optimal transceiver performance and to avoid exposure to excessive electromagnetic fields, the antenna system must be installed according to the instructions provided.

WARNING High voltages exist on the antenna during transmission and tuning. Do not touch the antenna during these activities. RF burns may result.

WARNING Install the earthing system or counterpoise as directed to prevent RF burns from any metal part of the transceiver.

WARNING You should not transmit from your transceiver or tune the antenna unless people are beyond the safe working distance of 1.5 m (5 ft) of any part of a 3040 Automatic Whip Antenna.

Safe working distance is based on continuous exposure to CW-type transmissions, as set out in the ICNIRP Exposure Guidelines (1998) for occupational exposure. Safe working distance can be reduced with normal voice communication.

EMC

To ensure compliance with the EMC Directive is maintained, you must:

- Use the standard shielded cables supplied from Codan (where applicable).

Electrical safety

To ensure compliance with the European LV Directive is maintained, you must install the 3040 Automatic Whip Antenna in accordance with the instructions in this handbook, and operate the 3040 Automatic Whip Antenna in accordance with the instructions in the relevant documentation provided with your transceiver.

FCC compliance

FCC Part 15 compliance

Any modifications made to the 3040 Automatic Whip Antenna that are not approved by the party responsible for compliance may void your equipment's compliance under Part 15 of the FCC rules.

The 3040 Automatic Whip Antenna has been tested and found to comply with the limits for a Class B device, pursuant to Part 15 of the FCC rules. These limits are designed to provide reasonable protection against harmful interference in a residential installation. This equipment generates, uses and can radiate radio frequency energy and, if not installed and used in accordance with the instructions, may cause harmful interference to radio communications. However, there is no guarantee that interference will not occur in a particular installation. If this equipment does cause harmful interference to radio or television reception, which can be determined by switching the equipment off and on, the user is encouraged to try to correct the interference by one or more of the following measures:

- reorient or relocate the receiving antenna
- increase the separation between the equipment and receiver
- connect the equipment into an outlet on a circuit different from that to which the receiver is connected
- consult the dealer or an experienced radio/TV technician for help

Register of hazardous substances

Table 7: 有毒有害物质列表 (Register of hazardous substances)

零件项目 (Component Name)	有毒有害物质或元素 (Hazardous Substances or Elements)					
3040 天线 (3040 Antenna)	铅	汞	镉	六价铬	多溴联苯	多溴二苯醚
3040 主体结构 (3040 Main Assembly)	X	O	O	O	O	O
玻璃纤维鞭状天线 (Fibreglass Whip)	X	O	O	O	O	O
不锈钢鞭状天线 (Stainless Steel Whip)	X	O	O	O	O	O
弹簧 (Spring)	O	O	O	O	O	O
控制电缆 (Control Cable)	X	O	O	O	O	O
同轴电缆 (Coaxial Cable)	X	O	O	O	O	O
天线安装手册 (Antenna Installation Handbook)	O	O	O	O	O	O

- 0 表示该有毒有害物质在该部件的所有均质材料中的含量，均在 SJ/T 11363-2006 标准所规定的限量要求以下。

Indicates that this toxic or hazardous substance, contained in all of the homogeneous materials for this part, is below the limit requirement in SJ/T 11363-2006.

- X 表示该有毒有害物质在该部件的至少一种均质材料中的含量，超出 SJ/T 11363-2006 标准所规定的限量要求。

Indicates that this toxic or hazardous substance, contained in at least one of the homogeneous materials used for this part, is above the limit requirement in SJ/T 11363-2006.

怎么阅读制造日期 - 方法如下：

How to read the date of manufacture:

产品序列号中的第一个数字或字母表示该产品在 2000 年或以后的制造年份。举例来说（数字 0-9）0=2000, 1=2001... 之后接着以字母代表制造年份 A=2010, B=2011...

The first character of the serial number provides the year of manufacture starting from the year 2000, that is, 0=2000, 1=2001...A=2010, B=2011...

产品序列号中的第二个数字或字母表示该产品的制造月份。举例来说（数字 1-9）1=一月份, 2=二月份... 之后接着以字母 A, B, C 代表剩下的制造月份 A=十月份, B=十一月份, C=十二月份。

The second character of the serial number provides the month of manufacture, that is, 1 to 9, A to C; A=10th month, B=11th month and C=12th month.

This page has been left blank intentionally.

Standards and icons

The following standards and icons are used in this handbook:

This typeface **Means...**

Italic a cross-reference or text requiring emphasis

This icon **Means...**



a step within a task

NOTE

the text provided next to this icon may be of interest to you

CAUTION

proceed with caution as your actions may lead to loss of data, privacy or signal quality

WARNING

your actions may cause harm to yourself or the equipment

Acronyms and abbreviations

This term...	Means...
4WD	four-wheel drive
CW	continuous wave
DC	direct current
EMC	electromagnetic compatibility
EPR	ethylene propylene rubber
ETSI	European Telecommunications Standards Institute
FCC	Federal Communications Commission
HF	high frequency
ICNIRP	International Commission on Non-Ionizing Radiation Protection
LV	low voltage
NVIS	near vertical-incident skywave
PIB	poly isobutylene
R&TTE	radio and telecommunications terminal equipment
RF	radio frequency
VSWR	voltage standing wave ratio

Units

NOTE Imperial dimensions are in United States Customary Units.

Measurement	Unit	Abbreviation
Current	ampere	A
Frequency	hertz	Hz
Impedance	ohm	Ω
Length	metre (inch/feet)	m (in/ft)
Power	watt	W
Temperature	degrees Celsius (Fahrenheit)	$^{\circ}\text{C}$ ($^{\circ}\text{F}$)
Time	second	s
Torque	newton-metre (pound-foot)	Nm (lb-ft)
Voltage	volt	V
Weight	gram (pound)	g (lb)

Unit multipliers

NOTE Units are expressed in accordance with ISO 1000:1992 ‘SI units and recommendations for the use of their multiples and of certain other units’.

Unit	Name	Multiplier
M	mega	1 000 000
k	kilo	1 000
m	milli	0.001

About this issue

This is the first issue of the Automatic Whip Antenna 3040 Installation Handbook.

Associated documents

This handbook is one of a series of documents associated with the 3040 Automatic Whip Antenna. The other documents are:

- Declaration of Conformity for the 3040 Automatic Whip Antenna (Codan part number 19-40366)

Numerics

3040 to transceiver connections 18

A

accessories 27

antenna

- cabling 17
- changing length 20
- components 4
- dimensions 4, 24
- earthing 16
- installing 18
- location 11
- mounting bracket 15

C

cabling 17

care and safety instructions 5

changing antenna length 20

compliance

- EMC and safety notices 31
 - electrical safety 32
 - EMC 31
 - radiation safety 31
- FCC 33
- R&TTE Directive 30
 - declaration of conformity 30
 - product marking and labelling 30

connectors 6

- antenna control 7

correct installation 10

E

earthing 16

EMC and safety notices

- compliance
 - electrical safety 32
 - EMC 31
 - radiation safety 31

environmental specifications 25

F

FCC compliance 33

footprint 12

G

general specifications 23

H

hazardous substances 34

height restrictions 15

L

location 11

M

mechanical specifications 24

mounting

- bracket 15
- footprint 12
- front
 - off-road vehicle 14
- rear
 - off-road vehicle 14
 - sedan vehicle 13

N

NVIS kit 21

O

optimal tuning point 20

overview 3

P

pinouts 7

R

- R&TTE Directive
 - compliance 30
 - declaration of conformity 30
 - product marking and labelling 30

S

- safety
 - electrical 32
 - radiation 31
- specifications 23
 - environmental 25
 - general 23
 - mechanical 24



www.codan.com.au



Asia Pacific (Head Office)

Codan Limited
81 Graves Street
Newton SA 5074
AUSTRALIA

T: +61 8 8305 0311
F: +61 8 8305 0411

asiasales@codan.com.au

Europe, Middle-East & Africa

Codan (UK) Ltd
Unit C4, Endeavour Place
Coxbridge Business Park
Farnham Surrey GU10 5EH
UNITED KINGDOM

T: +44 1252 717 272
F: +44 1252 717 337

uksales@codan.com.au

Americas

Codan US, Inc.
1 Fishers Road
Pittsford NY 14534
USA

T: +1 585 419 9970
F: +1 585 419 9971

hfsales@codanusinc.com