

MODEL CX-333

High Gain Tri-band
Ground Plane Antenna for 146 ,220 & 446MHz

Instruction Manual

Thank you for purchasing our products.

For your safety :

Read this manual carefully for proper handling and operation before using.
Keep this manual in a safe place for future reference.

【Features】

- Low-Loss and High Gain, based on SLC, Super-Linear-Converter.
- CX-333 is Wide-Band, and requires no Frequency adjustment.
- Heavy-duty fiberglass guarantees perfect water/pollution-proof and prevents QSB.
- Enjoy Tri-Band Communication with COMET Triplexer CFX-324A/B.

【Specifications】

Frequency : 146 MHz , 223MHz , 446 MHz
Gain : 146MHz / 6.5 dBi , 223MHz / 7.8dBi
446MHz / 9.0 dBi
Impedance : 50 Ω
VSWR : 1.5 or less
Length : approx. 3.1 m
Max Input Power : 120W (FM)
Weight : 1.5 kg
Mounting Mast Diameter : Φ30-62mm
Connector : M-Female (SO-239) type

【Parts List】

- | | |
|------------------------------------|-----|
| 1. Lower Element w/ FRP outershell | - 1 |
| 2. Upper Element w/ FRP outershell | - 1 |
| 3. Radial w/ Hex. nut | - 3 |
| 4. Power feeding section | - 1 |
| 5. Mount bracket | - 2 |
| 6. Mount support pipe | - 1 |
| 7. Lock bolt w/ sp.washer M6x10 | - 1 |
| 8. Hex.bolt w/ sp.washer M6x30 | - 2 |
| 9. U-Bolt w/sp.washer & Hex.nut | - 2 |
| 10. Hex. key Wrench | - 1 |
| 11. Hollow-set screw M3x3 | - 2 |

【How To Assemble】

1. How to assemble/mount

Connect the Lower Element and the Upper Element, using the Hex Wrench. (See Fig. 1)
Put the Upper Pipe into the Lower Pipe. Then, assemble the ABS Joint with rubber washer.

2. Assemble three radials. Fasten radial-lock Nuts securely with spanner etc.... (See Fig. 2)

3. Put two mount brackets on the mount support pipe. Pass the coax cable through the pipe, and attach it to power feeding section. Be sure to fasten hex bolts firmly. Then, attach support pipe onto the antenna. (See Fig. 3)

4. Mount all assembled antennas on your mast.

This antenna is so long. Keep your eyes on balance of this antenna and use as strong mast as you can, between 30 to 62mm dia.

*Make sure to use low loss coax cable.

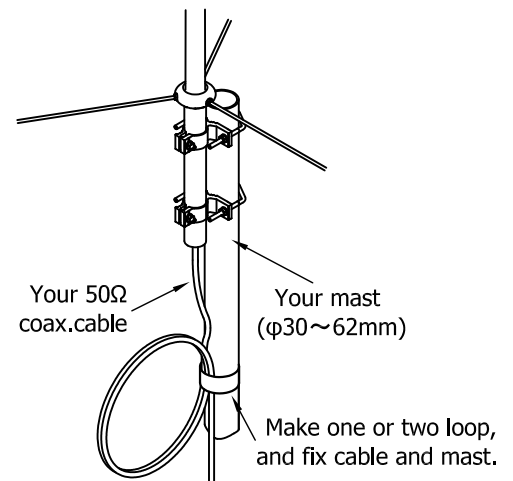
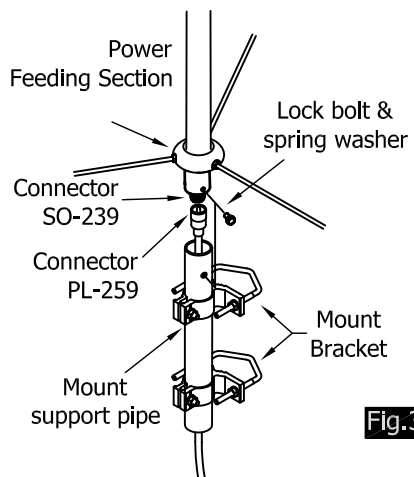
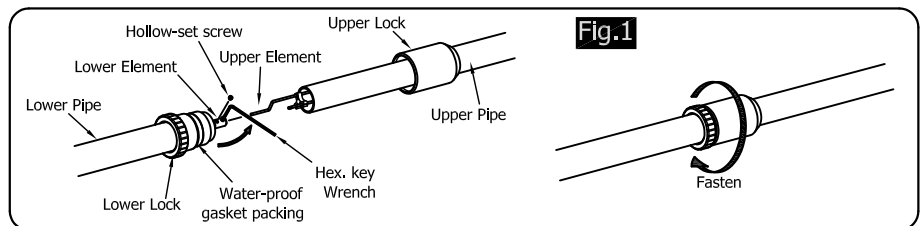
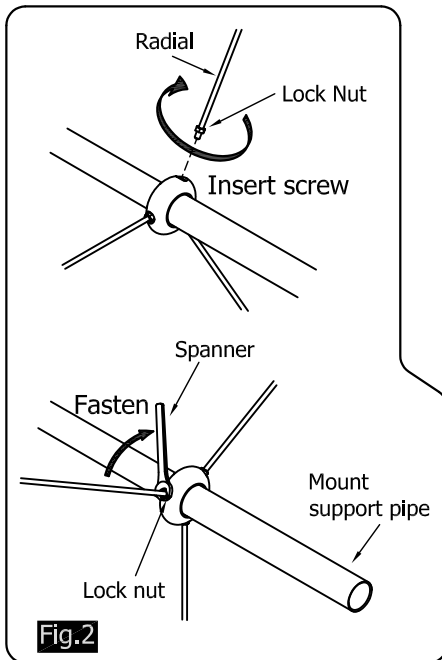

◆ Mount Bracket & U-Bolt

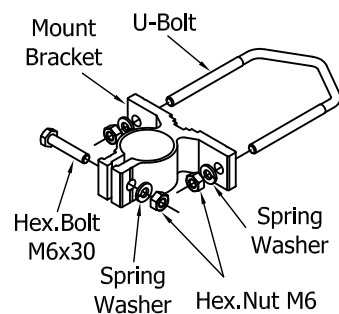

Note : For long-term use, water-proofing with glue, self-fusing tape, and/or vinyl tape is highly recommended.

⚠ Precautions for using

- This antenna is only for ham radio. Do not use this for other purposes.
- Operation outside the specification might damage the antenna.
- Adjust the antenna correctly. Elevated SWR could damage the antenna.
- Never attempt to modify or fix the antenna by yourself.
- Do not touch the antenna while transmitting.

◆ Specifications or appearance is subject to change without notice.

COMET CO.,LTD.

4-18-2, Tsuji, Minami-ku, Saitama-shi, Saitama-Pref, 336-0026, JAPAN
TEL : 81-48-839-3131 / FAX : 81-48-839-3136
URL : <http://www.comet-ant.co.jp/english>



Warning — Outdoor Installations



Important safety information:

The following instructions and any safety instructions that came with the equipment you are installing must be followed.

- Make sure all the tools and equipment you are using are in good condition. Use non-conductive ladders and all recommended safety equipment. Place equipment on level ground.
- Know the phone # to the local power company before installation begins.
- Look over the installation area and be sure there are no power lines overhead or anywhere contact can be made with them. Assume that all overhead lines are power lines.
- Always work together with an assistant. In case of emergency, this partner could save your life.
- Let falling towers or antennas fall, do not attempt to catch them.
- If anything comes in contact with a power line, leave it there and call the power company for assistance
- Foul weather days are not antenna or tower installation days.

Contacting power lines can be deadly:

Be sure no power lines are anywhere possible contact can be made. Antennas, towers and all supporting wires etc must be kept away. To make sure there is no possibility of contact with the tower, mast or antenna, the horizontal distance to the electrical line should be twice the total length of the mast/antenna. This safety measure will ensure that the mast will not contact electrical power during installation or later.

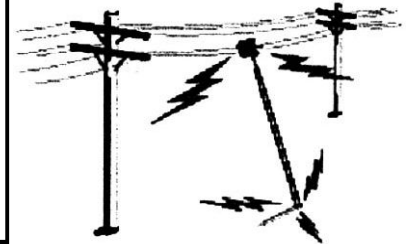

If a person comes in contact with electrical power and cannot move:

- Do not touch that person or you could be electrocuted
- Use a non-conductive dry board, stick or rope to push or pull the person away from contact with the electrical power.
- Once they are not contacting electrical power or you feel you cannot safely move them CALL 911, or summon professional assistance immediately.
- If certified, begin CPR until help arrives.

Make sure all towers and masts are securely grounded and cables connected to antennas have lightning arrestors. This will help prevent electrical and fire damage as well as human injury in case of a lightning strike, static build-up or short-circuit within equipment connected to the antenna.

Refer to the National Electrical Code for grounding details



NCG Company Ltd
www.natcommgroup.com
800/962-2611
Fax 714/630-4541