

Cushcraft

Amateur Radio Antennas

LFA-6M7EL

6 Meter 7 Element Loop Feed Antenna

INSTRUCTION MANUAL

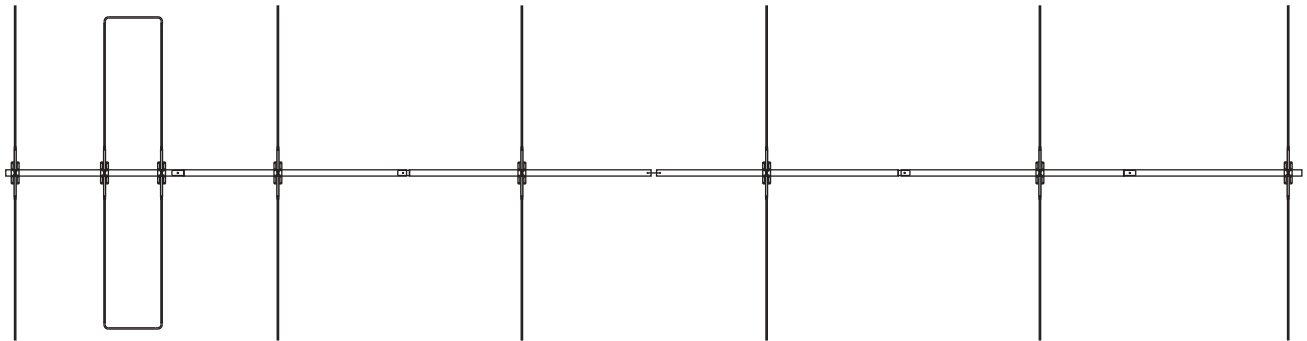

CAUTION: Read All Instructions Before Operating Equipment

Cushcraft
Amateur Radio Antennas

308 Industrial Park Road
Starkville, MS 39759 USA

Tel: 662-323-9538 Fax: 662-323-6551

GENERAL DESCRIPTION

The LFA (Loop Fed Array) Low-Noise Yagi is very different from the traditional dipole fed Yagi in many ways with its primary benefit being unwanted noise rejection. The LFA has a rectangular shaped, full wave loop driven element that is laid flat on the boom between and in-line with the parasitic elements . Then there is the way in which the loop functions. The smaller end sections which run parallel to the boom, are engineered to be 180 degrees out-of-phase with each other. This provides the same effect as is seen within ladder-line feeder; each side cancels the other out and therefore, minimum radiation occurs. In practice this translates to highly suppressed side lobes and side-on signal rejection. This feature also plays a role in reducing F/B (Front to Back ratio), F/R (Front to Rear ratio) and broad-banding of the antenna too. It is these attributes which help give the LFA class-leading all-round performance at almost any boom length and for any given band.

UNPACKING

Unpack the antenna and check the parts against the Parts List and the drawings. This will simplify the antenna assembly. Parts have been separated when possible to aid in assembly. Make sure you have the necessary room to assemble the antenna before unpacking. This antenna will be very large when finished. Try to assemble it in a large open area clear of obstructions and people. A driveway and a couple of saw horses or other means of support will make it easy to handle the antenna when putting it together. Assembly over grass is not recommended. There are lots of small things that can get lost forever in grass. Some parts may have extras included so don't worry if you have some left over when your done. The design of the antenna makes it very easy to assemble.

Tools you will need

Tape measure in inches. A tape measure in feet and inches will do but you will have to convert.

7/16, wrench and/or nut driver

½ inch wrench

Phillips screwdriver

Flat head screwdriver for hose clamps

WARNING

WHEN INSTALLING YOUR SYSTEM, TAKE EXTREME CARE TO AVOID ANY ACCIDENTAL CONTACT WITH POWERLINES OR OVERHEAD OBSTRUCTIONS. FAILURE TO EXERCISE THIS CARE COULD RESULT IN SERIOUS OR FATAL INJURY

Assembly of the Boom

Slide the boom insert into boom ends, as shown in Figure 1. Select the boom-to-mast bracket and clamp parts. Loosely assemble them on the boom ends.

Secure the boom ends and brackets together with four (4) 1/4"-20 x 3/4" bolts, lockwashers and nuts, and two (2) 5/16"-18 x 2 3/4" bolts, lockwashers and nuts.

Tighten these six bolts securely. The casting-to-boom bracket may deform slightly when the four 1/4" bolts are tightened. This is normal.

Assemble the two cast aluminum brackets (1) on your temporary mast at about 4 feet (1.2 m) above ground. An eight foot length of 2" ABS or PVC plastic drain pipe makes an inexpensive temporary mast. Secure the two brackets together using two (2) 5/16"-18 x 3" bolts, lockwashers and nuts. Tighten these two bolts evenly until the brackets are snug.

Assemble the boom as shown below. Use the 1/4-20 x 2-1/2 bolts, lock washers and nuts.

figure 1

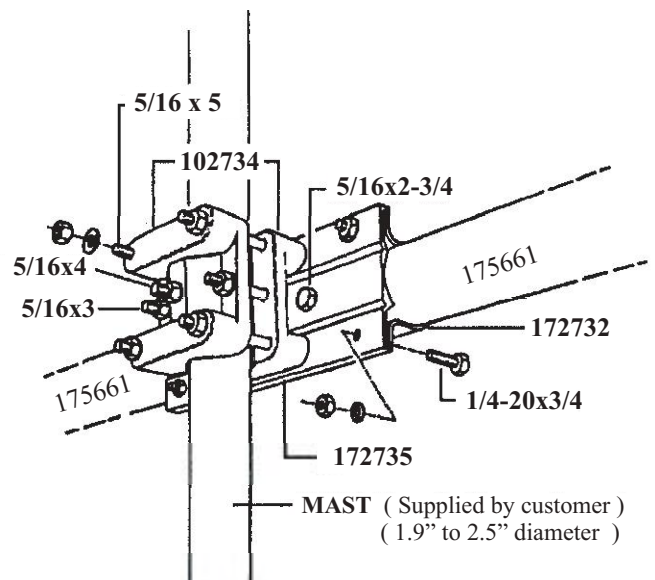

Note: If you use a galvanized 1-1/2 schedule 40 or 80 pipe as a mast, it has an O.D. of 1.9". You will need to put two split lockwashers under the 5/16 nuts on the four long bolts.

Boom Insert (171541)

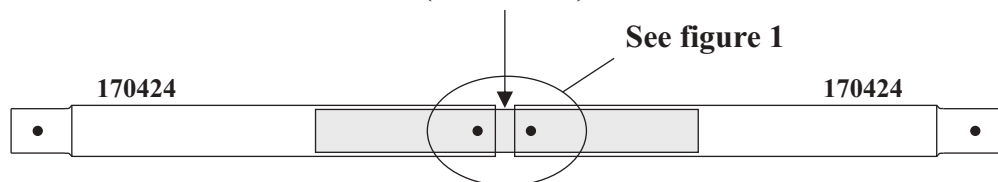

Boom is symmetrical (same on both sides)

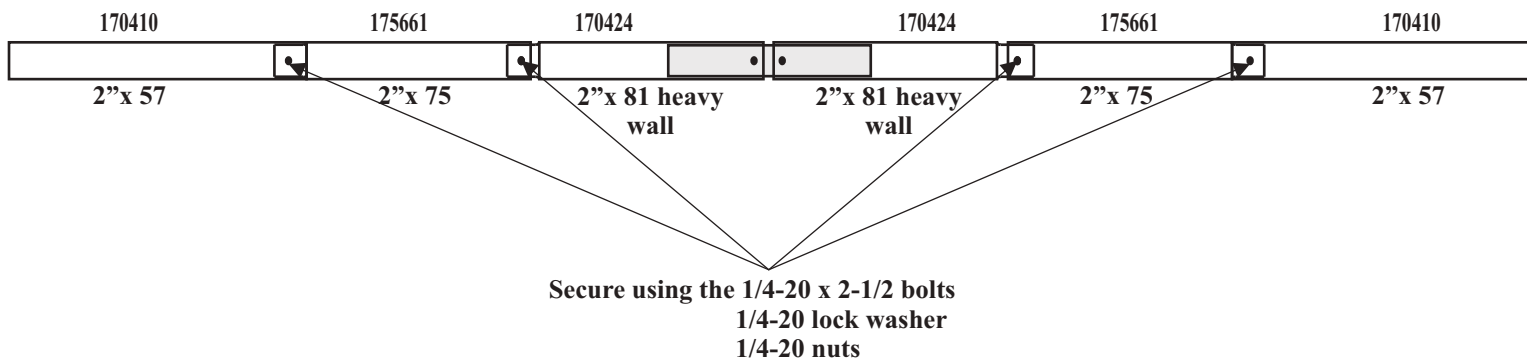

Secure using the 1/4-20 x 2-1/2 bolts
1/4-20 lock washer
1/4-20 nuts

Assemble the brackets as shown in Figure 2 and locate them on the boom assembly as shown in Figure 3. It is easier to assemble the brackets on the boom at the correct location, rather than try to slide them on the boom. If you are going to leave this assembly unattended for more than 15 minutes, we suggest that you tighten the eight (8) bolts on each bracket, so that they do not vibrate off. Do not tighten the anchor bolts on the elements until the elements are completely installed and aligned. Mark the bracket location on the boom with a marker at the edge of the bracket instead of the center. This will ensure the mark is still visible when the bracket in is the correct spot. Start from the rear of the boom and work forward. The measurements are given in total inches from the rear of the boom. If you need the distance from each element to the next you may subtract the bracket measurements to obtain this value. Total distance is given for better accuracy in element placement. Distance between elements measurements will cause cumulative errors as each element is placed.

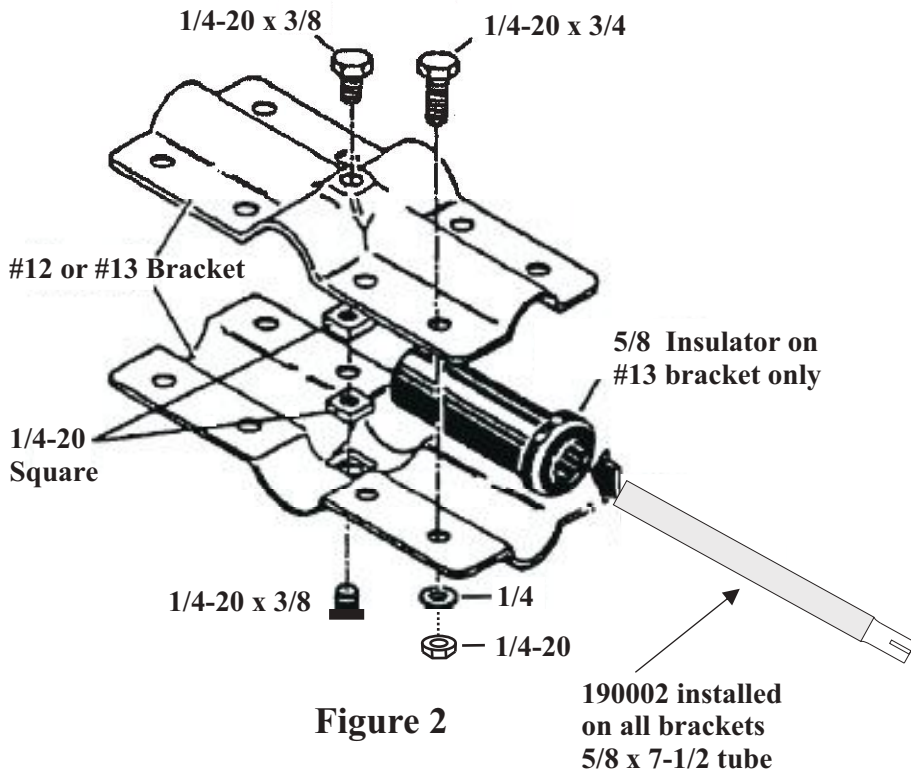
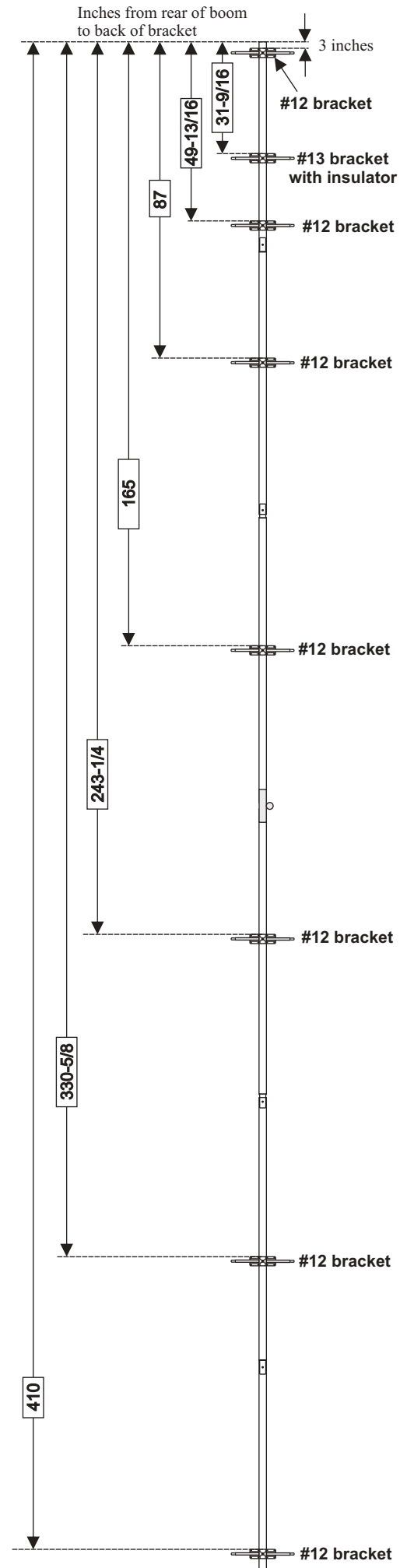
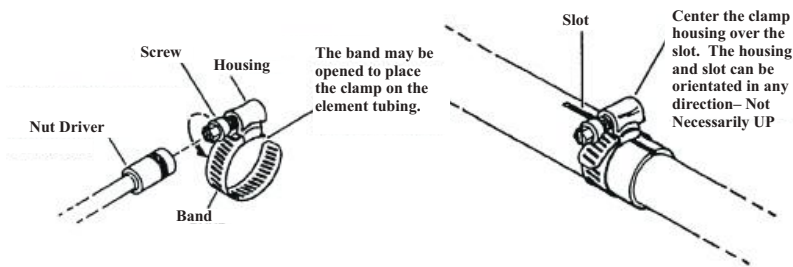
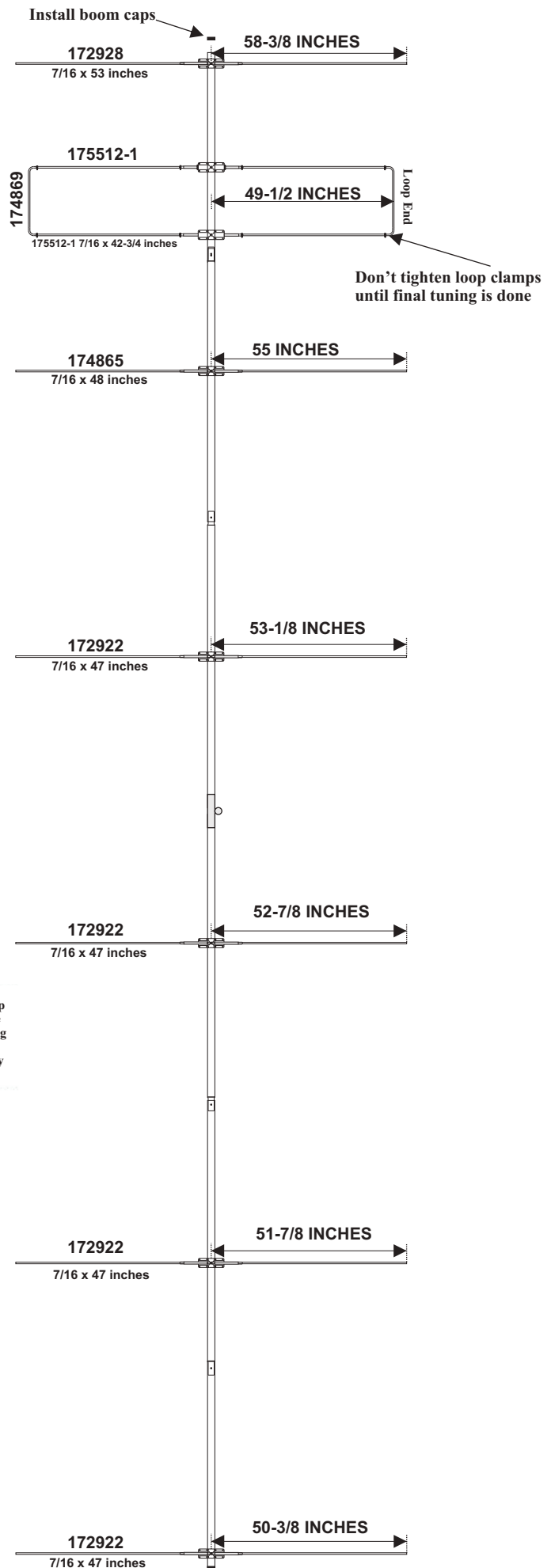

Figure 3



Identify the element tubes by their total length given on the left side of the diagram. Install the tubes in the locations shown. The element lengths are given from the center of the boom to the tip of the tube. For the driven element, the distance is from the center of the boom to the outer edge of the loop end. Slide a #4 hose clamp over the loop ends before installing. The loop will need to be adjusted for SWR so this measurement is just a starting point. Leave the clamps that secure the loop end loose. There should be enough friction between the tubes to keep them in place.

Verify the measurements on the elements and tighten the clamps on the reflector and directors. Do not overtighten the clamps. They can be damaged if you use too much torque. A nut driver or screwdriver will do the job. Do not use a wrench or socket on the clamps. A wrench will strip the threads on the band. Install the 7/16 tube caps on the ends of the elements.



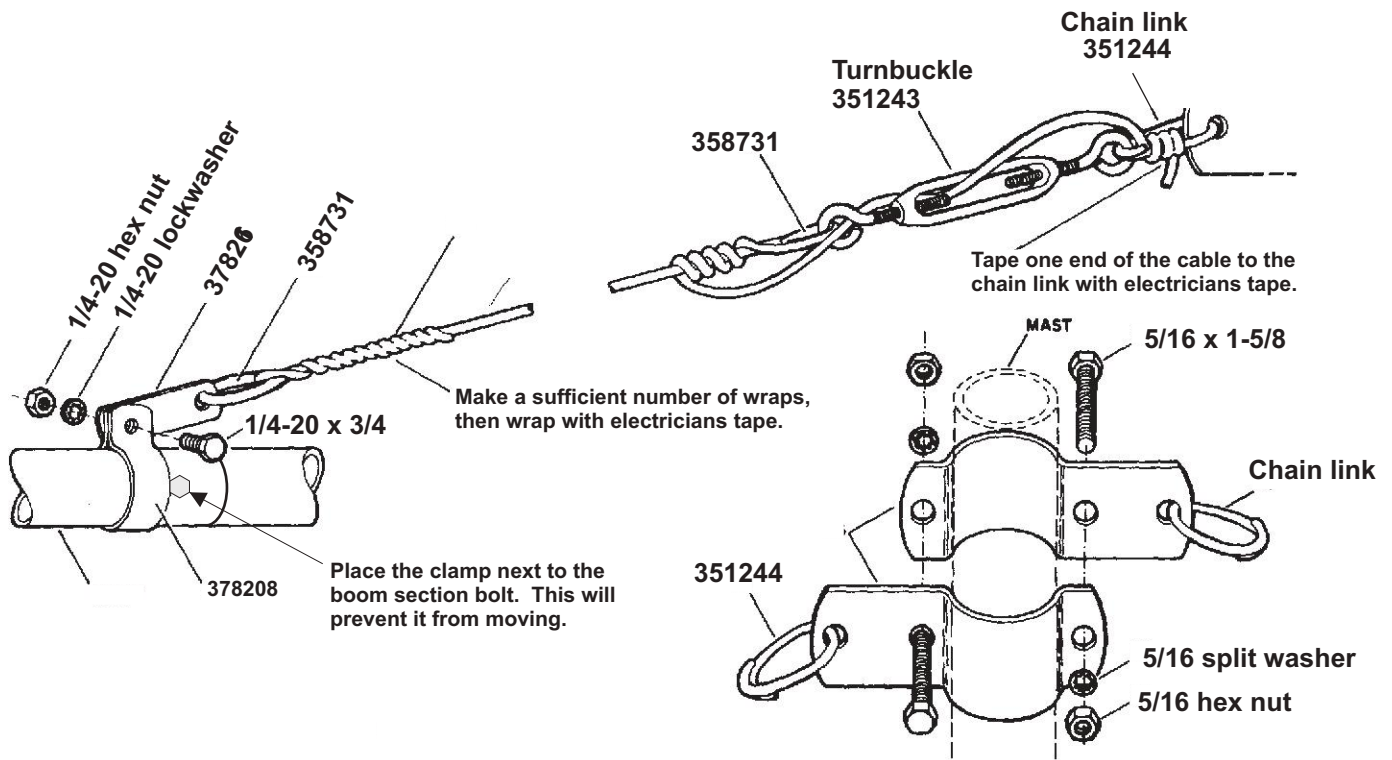

Install the boom support cable as shown. You will need to cut the cable to the correct length. 30 feet has been supplied. Cut this length in half and use one for each side. To adjust tension on the cables, slide the mount up and down to level the boom. Use the turnbuckles for fine adjustment after the clamp has been secured. Make sure after your done adjusting to route the wire as shown in the above diagram. Looping the wire through the turnbuckle will prevent it from turning and releasing tension on the wire. You should have more support wire than needed. The excess will depend on how high you mount the support bracket above the antenna.

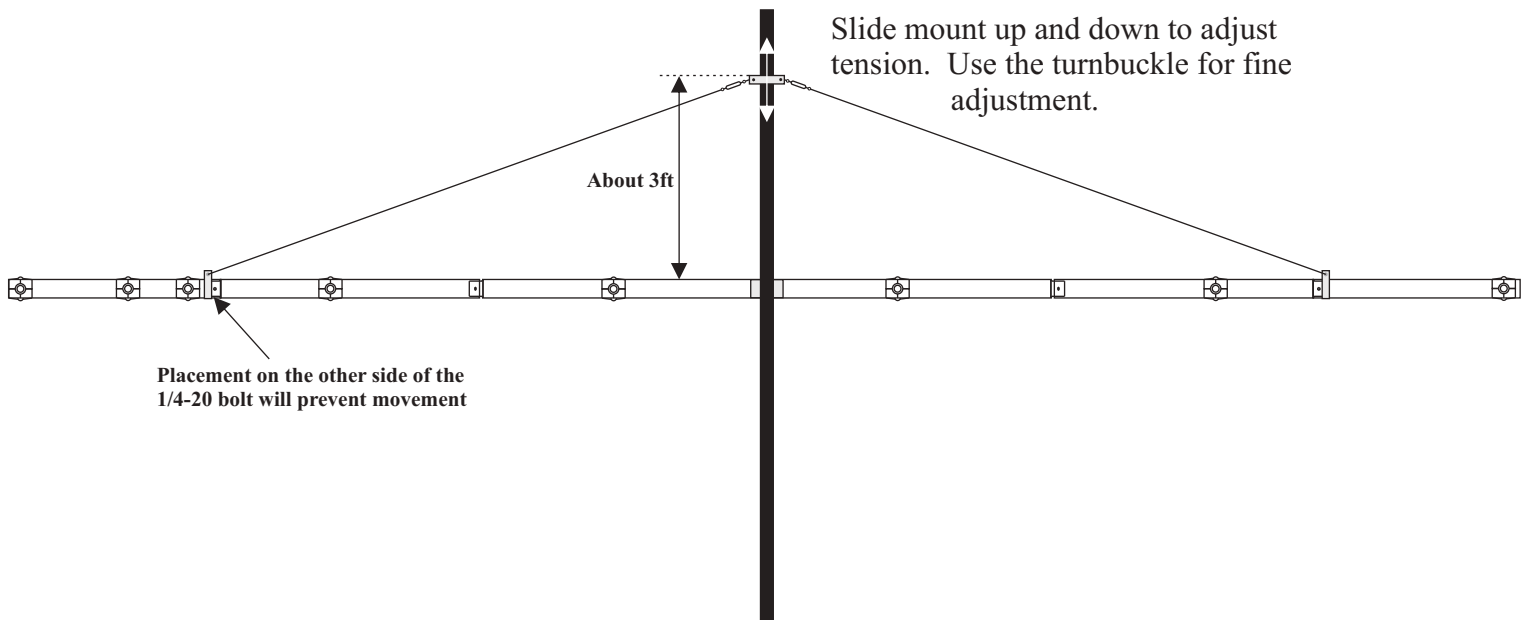

FEED LINE CONNECTION

Connect your feed line as shown in the diagram. One side of the driven element is connected to the center conductor of the coax and the other is connected to the shield. Route the conductors so that they do not touch the #13 bracket. Seal the

Coax where the conductors split using an appropriate sealant. Water should never be allowed to enter the coax conductor. Use of a balun is recommended. An example of a coaxial balun is shown below. You may use this method or any commercial version you wish. Placement of the balun does not have to be at the mast. It is better to have it close to the feed point

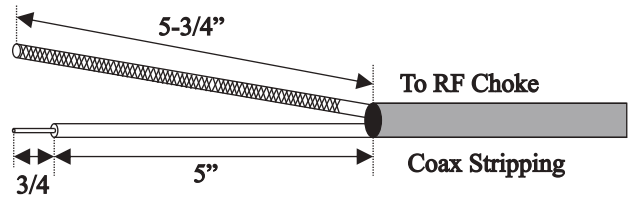

Center Conductor
Shield

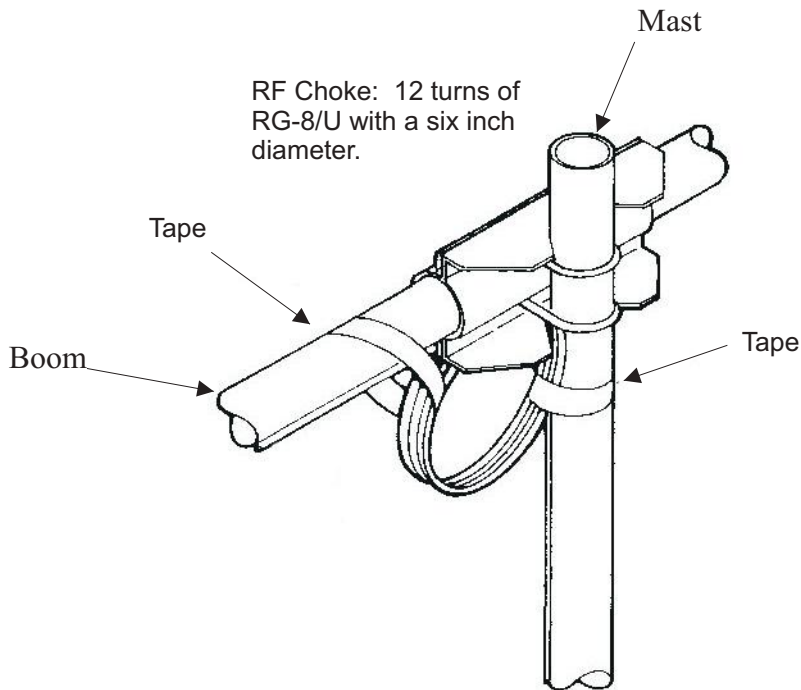
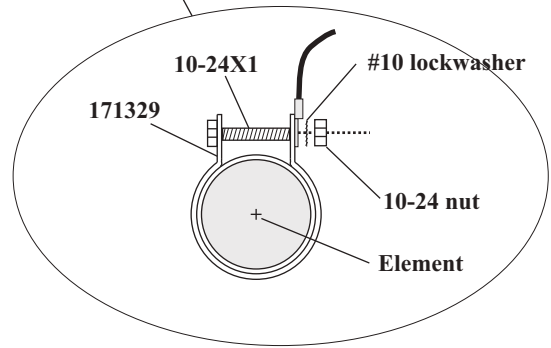

**Example of Balun attachment
(not the same as your mount)**

FINAL TUNING

Start by making sure the distance from the loop end to the center of the boom on one side is the same as the distance on the other side. These distances must be the same. If you move one, you must move the other. The antenna will not tune correctly if these are not the same. The antenna must be at least 10 feet off the ground for initial tuning. Mount the antenna on a temporary mast or other support when checking the SWR

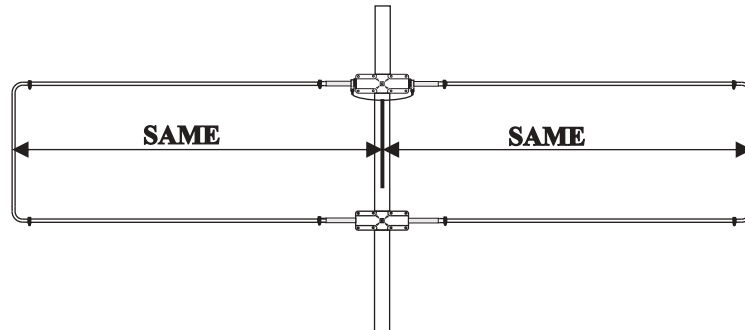

Check the antenna using a SWR analyzer or radio with a good quality wattmeter that indicates SWR. The antenna should have a SWR dip at or around 50.125 MHz . If you do not see a dip at all, check all your connections and try again. If the dip is too low in frequency, then the loop ends should be moved in toward the boom. Remember to move both sides the same amount. Move them a small amount each time and recheck the SWR. The dip point should move up as you move the loop ends in toward the boom. Continue this adjustment until the frequency you desire has the lowest SWR. If the frequency is too high then move the loop ends out away from the boom in the same manner. Do not tighten the loop clamps each time you adjust the distance. The loop ends should have enough friction to remain where they are without the clamps. When your happy with where the antenna is tuned, then tighten the clamps.

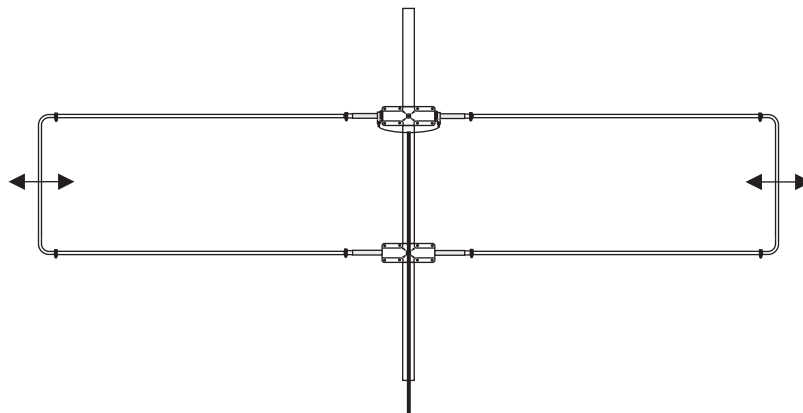

Your antenna is now ready for mounting. This antenna is large and too much for one person to handle. Make sure before you start that you have everything you need and a friend to help with the installation. Do not attempt to install the antenna alone. Do not install the antenna in a location where it can come into contact with electrical lines or any location it could possibly fall into electrical lines.

GENERAL INSTALLATION INSTRUCTIONS FOR MAST MOUNTED ANTENNAS

1. Assemble your new antenna on the ground at the installation site. Keep separate assembly instructions that come with it. Large CB and Amateur beams may have to be finally assembled on the tower or mast.
2. On the ground, clamp the antenna to mast and connect the coaxial cable to the antenna.
3. To insure that the mast does not fall the "wrong way" it should get away during the installation or takedown, durable non-conductive rope should be secured at each two foot level as the mast is raised. The boss stands in a position where he can yank or pull the ropes if the need arise to deflect the falling mast away from hazards (such as power lines) into a "safe fall" (such as a yard or driveway). The ropes are tied taut at the base of the mast after installation and in place at the various levels.
4. Install selected mounting bracket.
5. If you are going to use guy wire installation instead of a mounting bracket:
 - install guy anchor bolts
 - estimate length of guy wire and cut
 - attach a mast using guy ring
6. Carefully take antenna and mast assembly to mounting bracket and insert. Tighten camp bolts. In case of guyed installation, it will be necessary to have at least a second person hold the mast upright while the guy wires are attached and tightened to the anchor bolts.
7. Install self-adhering "DANGER" label packaged in antenna hardware kit at eye level on your mast.
8. Install ground rod to drain off static electricity build-up and connect ground wire to mast and ground rod. Use special ground rods, not a spare piece of pipe.

EXAMPLE OF ANTENNA GROUNDING AS PER NATIONAL ELECTRICAL CODE INSTRUCTIONS

1. Use No. 10 AWG copper or No. 8 AWG or larger copper-clad steel or bronze wire, as ground wires for both mast and lead-in. Securely clamp the wire to the bottom of the mast.
2. Secure lead-in wire from antenna to antenna discharge unit and mast ground wire to house with stand-off insulators spaced from 4 feet (1.2 meters) to 6 feet (1.8 meters) apart.
3. Mount antenna discharge unit as close as possible to where the lead-in wire enters the house.
4. Drill a hole in wall (CAREFUL! There are wires in that wall.) near your set just large enough to permit entry of cable.
5. Push cable through hole and form a rain drip loop close to where it enters the house.
6. Put small amount of caulking around cable where it enters house to keep out drafts.
7. Install static electricity discharge unit.
8. Connect antenna cable to the set.

You should not attempt to raise a mast in excess of 30 feet in height/length (not including the antenna proper) in a fully-extended condition. Thirty to fifty foot tubular masts must be elevated, a section at a time, with the base or outer section secured in place with guy wires. GET PROFESSIONAL HELP.

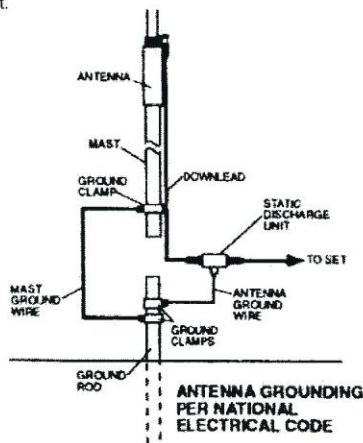

WARNING

INSTALLATION OF THIS PRODUCT NEAR POWER LINES IS DANGEROUS. FOR YOUR SAFETY, FOLLOW THE ENCLOSED INSTALLATION DIRECTIONS.

HOW TO INSTALL YOUR OUTDOOR ANTENNA SAFELY IN ACCORDANCE WITH THE RECOMMENDATIONS OF THE U.S. CONSUMER PRODUCT SAFETY COMMISSION

YOU, YOUR ANTENNA, AND SAFETY

Each year hundreds of people are killed, mutilated or receive severe permanent injuries when attempting to install an antenna. In many of these cases, the victim was aware of the danger of electrocution, but did not take adequate steps to avoid the hazard.

For your safety, and to help you achieve a good installation, please **READ** and **FOLLOW** the safety precautions below. **THEY MAY SAVE YOUR LIFE!**

1. If you are installing an antenna for the first time, please, for your own safety as well as others, seek **PROFESSIONAL ASSISTANCE**. Consult your dealer. He can explain which mounting method to use for the size and type antenna you are about to install.
2. Select your installation site with safety, as well as performance, in mind. (Detailed information on Site Selection appears in a separate section of this booklet.) **REMEMBER: ELECTRIC POWER LINES AND PHONE LINES LOOK ALIKE. FOR YOUR SAFETY, ASSUME THAT ANY OVERHEAD LINES CAN KILL YOU.**
3. Call your electric power company. Tell them your plans and ask them to come look at your proposed installation. This is a small inconvenience considering **YOUR LIFE IS AT STAKE**.
4. Plan your installation procedure carefully and completely **before** you begin. Successful raising of a mast or tower is largely a matter of coordination. Each person should be assigned to a specific task, and should know what to do and when to do it. One person should be designated as the "boss" of the operation to call out instructions and watch for signs of trouble.
5. When installing your antenna, **REMEMBER: DO NOT** use a metal ladder. **DO NOT** work on a wet or windy day. **DO** dress properly -shoes with rubber soles and heels, rubber gloves, long sleeve shirt or jacket.
6. If the assembly starts to drop, get away from it and let it fall. Remember, the antenna, mast, cable and metal guy wires are all excellent conductors of electrical current. Even the slightest touch of any of these parts to a power line complete an electrical path through the antenna and the **installer-THAT'S YOU!**
7. If any part of the antenna system should come in contact with a power line-**DON'T TOUCH IT OR TRY TO REMOVE IT YOURSELF. CALL YOUR LOCAL POWER COMPANY.** They will remove it safely.

If an accident should occur with the power lines call for qualified emergency help immediately.

931525_AB

SITE SELECTION

Before attempting to install your antenna, think where you can best place your antenna for **safety** and performance.

To determine a safe distance from wires, power lines and trees:

1. Measure the height of your antenna.
2. Add this length to the length of your tower or mast, and then
3. Double this total for the minimum recommended safe distance.

If you are unable to maintain this safe distance, **STOP! GET PROFESSIONAL HELP.** Many antennas are supported by pipe masts attached to the chimney, roof or side of the house. Generally, the higher the antenna is above the ground, the better it performs. Good practice is to install your antenna about 5 to 10 feet above the roof line and away from power lines and obstructions. Remember that FCC limits your antenna height to 60 feet. If possible, find a mounting place directly above your set, where the antenna wire can take a short, vertical drop on the outside of the house for entry through a wall or window near the set. Your dealer carries a complete line of installation hardware.

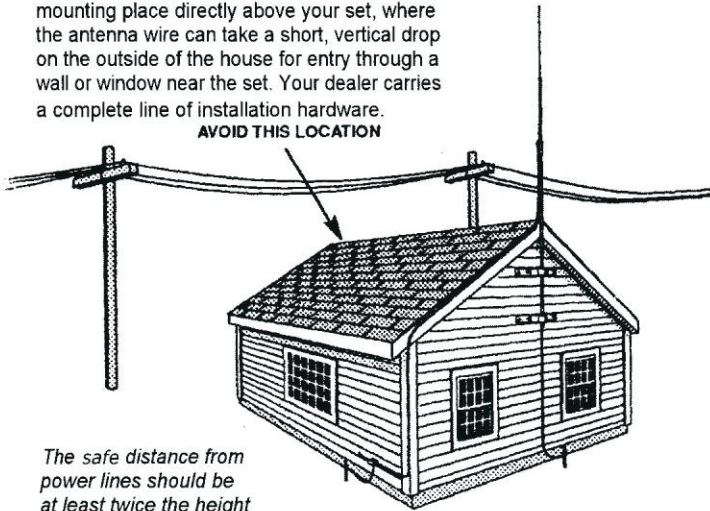

The safe distance from power lines should be at least twice the height of the antenna and mast combined.

TELESCOPING MAST

Guy wires should be equally spaced in at least three directions. Use at least three guy wires for each 10 foot section of mast.

SIDE OF HOUSE MOUNTING

The safe distance from power lines is at least twice the height of antenna and mast combined. Where roof overhang is not excessive, the side of the house provides a convenient mounting. Position the brackets over a stud if possible, one above the other, and space two or three feet apart. For metal siding, first mark mounting holes, then drill pilot holes through the siding to accept mounting screws.

TOWER

Tower safety is paramount to a good installation and requires that you take location, tree growth, soil depth and proximity to buildings into consideration. Tower foundations must be securely based on a solid concrete/ tower mounting plate. An alternative is to sink a 4-6 foot section of tower into a concrete base for an extremely rugged mount. Proper guying is essential to a safe weather-resistant installation that must handle severe wind loading and is best accomplished with preformed guy grips, torque brackets and turnbuckles. When working on towers always use a safety belt made of high quality web-type material

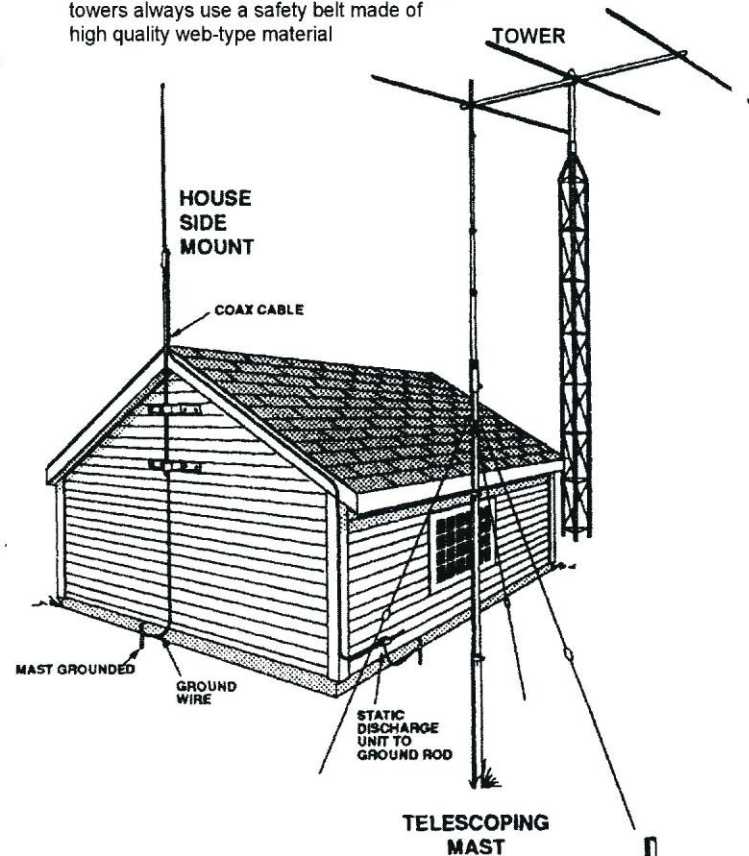

CHOOSE A PROPER SUPPORT AND MOUNTING METHOD

However you decide to mount and support your antenna always make sure that safety is your first concern. Some of the more common installation methods are illustrated below.

ROOF MOUNTED

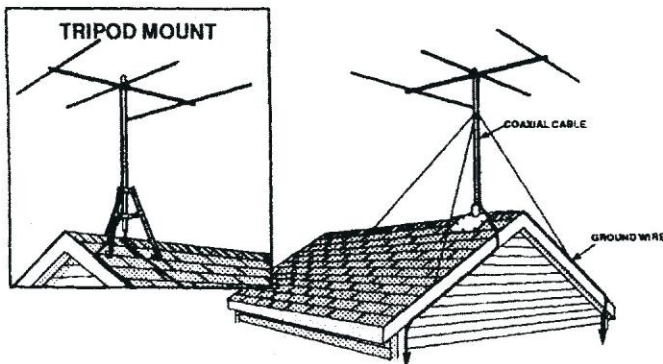

ROOF MOUNTING

The swivel feature of "universal" type mounting brackets makes a convenient antenna mount for flat or peaked roofs. One clamp type bracket is used with 3 or 4 guy wires equally spaced around the mast and anchored to the roof or eaves by eyebolts. Apply roofing compound around the base of the bracket, screws and eyebolts for moisture sealing.

CHIMNEY MOUNTING

The chimney is often an easy and convenient mounting place. But the chimney must be strong enough to support the antenna in high winds. Do not use a chimney that has loose bricks or mortar. A good chimney mount makes use of a 5 or 10 foot, 1-1 1/4" diameter steel mast, and a heavy duty two strap clamp-type bracket. Install the upper bracket just below the top course of bricks, and the lower bracket two or three feet below the upper bracket. For maximum strength, space the brackets as far apart as possible.

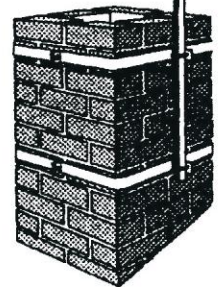

PARTS LIST

PN	DESC	QTY
172928	7/16 tube	2
175512	7/16 tube	4
174865	7/16 tube	2
172922	7/16 tube	4
102734	mast brick	2
172732	mast clamp	1
172735	mast plate	1
455625	2" CAP	2
505266	1/4-20 X 3/4 BOLT	53
554099	1/4-20 NUT HEX	55
551367	1/4-20 NUT SQUARE	12
500156	1/4-20 X 3/8 BOLT	12
562961	1/4 LOCK WASHER	55
500392	5/16-18X3	2
500349	5/16-18X5	4
506968	5/16-18X 2-3/4	2
555747	5/16 NUT	9
564792	SPLIT WASHER 5/16	9
5142400	5/16-18X4	1
171329	5/8 CLAMP	2
165919	#13 bracket	2
161409	#12 bracket	10
170410	boom tube	2
175661	boom tube	2
175667	boom insert	1
475639	7/16 tube cap	8
174869	6 mtr loop end	2
190002	5/8 x 7.5 tube	12
461057	5/8 insulator	2
504069	10-24 x 1 bolt	2
554071	10-24 nut	4
565697	#10 lockwasher	2
505734	1/4-20 x 2-1/2 bolt	2
745-3104S	#4 hose clamp	16

LIMITED WARRANTY

Cushcraft Amateur Radio Antennas, 308 Industrial Park Rd., Starkville, MS 39759, warrants to the original consumer purchaser for one year from date of purchase that each Cushcraft antenna is free of defects in materials or workmanship. If, in the judgment of Cushcraft, any such antenna is defective, then Cushcraft Amateur Radio Antennas will, at its option, repair or replace the antenna at its expense within thirty days of the date the antenna is returned (at purchasers expense) to Cushcraft or one of its authorized representatives. This warranty is in lieu of all other expressed warranties, any implied warranty is limited in duration to one year. Cushcraft Amateur Radio Antennas shall not be liable for any incidental or consequential damages that may result from a defect. Some states do not allow limitations on how long an implied warranty lasts or exclusions or limitations of incidental or consequential damages, so the above limitation and exclusion may not apply to you. This warranty gives you specific legal rights, and you may also have other rights that vary from state to state. This warranty does not extend to any products that have been subject to misuse, neglect, accident or improper installation. Any repairs or alterations outside of the Cushcraft factory will nullify this warranty.