

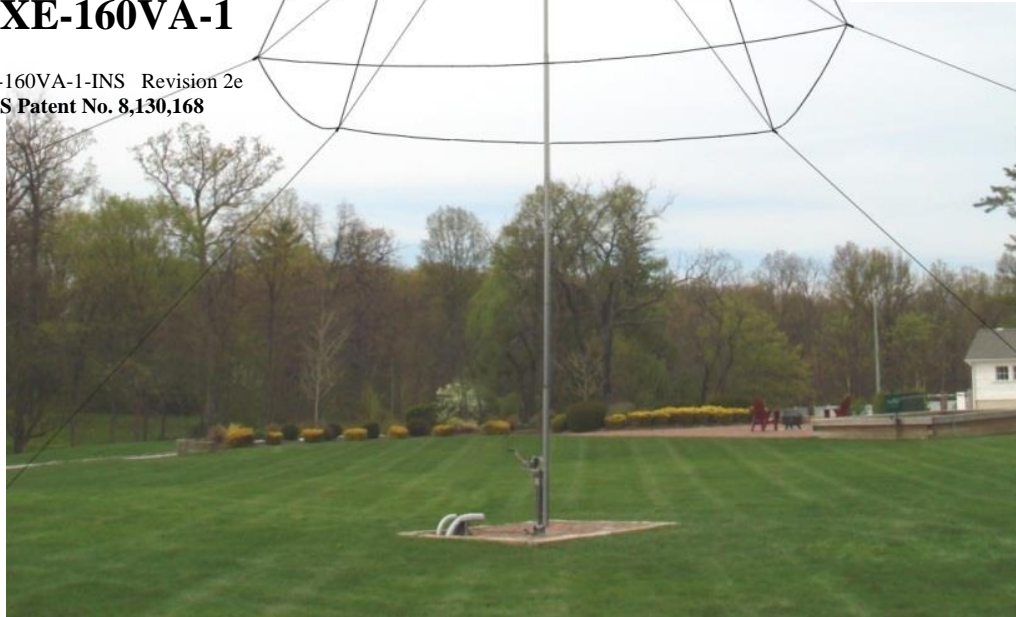

160 Meter Thunderbolt® Vertical Antenna

DXE-160VA-1

DXE-160VA-1-INS Revision 2c
US Patent No. 8,130,168



[Wires and ropes were enhanced in this photograph so they would show up]

© DX Engineering 2021

1200 Southeast Ave. - Tallmadge, OH 44278 USA

Phone: (800) 777-0703 · Tech Support and International: (330) 572-3200

Fax: (330) 572-3279 · E-mail: DXEngineering@DXEngineering.com

Table of Contents

Introduction & Features	2
Warning	3
Tools Required	3
Manual Updates and Information	3
Installation Sequence	4
Site Selection	4
Mounting Pipe	4
Coaxial Cable to Mounting Pipe	5
Radial System	6
Assembly Notes	6
Radial Plate to Mounting Pipe	7
Attaching Ground Radial Wires to the Radial Plate	7
Overall Pivot and Antenna Base Assembly Drawing	8
Pivot Base and Lower Antenna Assembly	8
Mounting and using the Optional DXE-VRW-1 Manual Winch	15
General Information about Aluminum Tubing	18
Assembling the Vertical Sections	19
Mating the Vertical Elements to the Pivot Base Assembly	26
Base Series and Shunt Coil Assembly and Installation	28
Capacity Hat Information	30
Capacity Hat Assembly	31
Installing the Capacity Hat on the Antenna	36
Capacity Hat Bottom Wires	37
No Slip Knots	39
Guy Rope Installation	39
Tuning	42
Locking the Pivot Base	44
DXE-160VA-1 Base Exploded View with Parts Numbered	45
DXE-160VA-1 Part Lists	46
Additional Material Required, Not Supplied	47
Suggested Parts Not Included	47
Optional Accessory Items	48
Technical Support and Warranty	51

Introduction

Congratulations on obtaining your DX Engineering **DXE-160VA-1** Monoband Vertical Antenna! Now you can have a high-performance vertical antenna specifically for the 160 meter band. Achieve the strongest possible presence at your power level and be competitive.

The 160 meter band vertical antenna is tunable with an impressive 40 kHz bandwidth. This means that operation on the CW DX frequencies and DX Phone frequencies is within range of most radio internal tuners - no antenna changes are necessary.

A custom designed capacity hat system allows this vertical monoband antenna to get on 160 meters with unparalleled success in an antenna that is only 55 feet tall.

The DX Engineering **DXE-160VA-1** is a slow taper 55-foot high Monoband Vertical Antenna system. The vertical antenna is specifically designed to operate on 160 meters. Included with this antenna system is a patented rugged stainless steel pivot fixture (*US Patent No. 8,130,168*) for ease of assembly and adjustments. Engineered with 6061-T8 and 6063-T832 corrosion-resistant aluminum tubing, stainless steel mounting brackets and stainless steel hardware, this antenna is very durable and attractive.

Why Does This Antenna Perform So Well for Its Height?

The top-hat is large enough that the current along the radiator is almost constant. Typical shortened verticals for this band, with smaller top-hats have currents that vary along the length and end up producing much less signal strength. This also works in the receive mode to let you hear weaker signals although at this frequency range Dedicated Receiving Antennas are almost a must.

Features

High Efficiency Design

- 5 kW SSB and CW rated - unparalleled reliability
- Custom designed capacity hat engineered for top performance
- DX Engineering Adjustable Matching Network configures the lowest SWR
- 160 meter broad 2:1 SWR bandwidth - 40 kHz
- Lowest possible take-off angle reduces domestic QRM signals

High Strength Pivoting Fixture - *US Patent No. 8,130,168*

- Ultra-rugged construction starts with 3 inch OD Aircraft Grade heavy wall tubing
- Withstands steady-state winds in excess of 50 mph
- Massive Extren[®] insulator channel

The optional **DXE-VRW-1** Manual Winch for easy one-person raising and lowering of the antenna is available from DX Engineering. You can move the **DXE-VRW-1** winch between similar antennas in a multi-antenna installation.

This antenna system requires the installation of a heavy duty mounting pipe set in concrete. Specifically, 3" OD (max) high strength galvanized steel tubing with 0.250" minimum wall thickness and 7' minimum length, which is available from DX Engineering; part number **DXE-VGMT-3CG**. A customer supplied 2-1/2" Schedule 80 pipe that has an outside diameter of 2.875"

is also suitable. Thirty six inches of the mounting pipe should extend above ground level. **Depth of the mounting hole and amount of concrete is dependent on local soil type, condition and antenna guying.**

WARNING!

INSTALLATION OF ANY ANTENNA NEAR POWER LINES IS DANGEROUS



Warning: Do not locate the antenna near overhead power lines or other electric light or power circuits, or where it can come into contact with such circuits. When installing the antenna, take extreme care not to come into contact with such circuits, because they may cause serious injury or death.

Overhead Power Line Safety

Before you begin working, check carefully for overhead power lines in the area you will be working. Don't assume that wires are telephone or cable lines: check with your electric utility for advice. Although overhead power lines may appear to be insulated, often these coverings are intended only to protect metal wires from weather conditions and may not protect you from electric shock

Keep your distance! Remember the 10-foot rule: When carrying and using ladders and other long tools, keep them at least 10 feet away from all overhead lines - including any lines from the power pole to your home.

Tools Required

- Two 9/16" wrenches, (one of them should be open-end)
- One 7/16" open end wrench
- Two 3/4" wrenches
- Medium size flat blade screwdriver or 5/16" nut driver for the element clamps
- Small Phillips Head screwdriver for coil taps
- Tape measure
- Felt-tip marker
- Soldering Iron and Solder
- Knife for cutting guy ropes

Manual Updates and Information

Every effort is made to supply the latest manual revision with each product. Occasionally a manual will be updated between the time your DX Engineering product is shipped and when you receive it. Please check the DX Engineering web site (www.dxengineering.com) for the latest revision manual.

Please - Take the time to read the entire manual before you start assembly. There are numerous photos and drawings to look at, and if you read the entire manual first, you'll get a better feel for the overall construction methods described. Assembly is not difficult, but there are a number of parts that must go together in a certain sequence to make assembly easier.

Installation Sequence

1. Site Selection
2. Mounting Pipe
3. Coaxial Cable to Mounting Pipe
4. Radial System
5. Pivot Base Assembly (Patented)
6. Antenna Assembly
7. Base Series & Shunt Coil Assembly
8. Capacity Hat assembly
9. Guying
10. Tuning

Site Selection

Select a mounting location clear from power lines, structures and other antennas by a minimum of 65 feet (55 + 10 ft. safety rule). **Consider overhead power lines, utility cables and wires.** The further away the vertical is mounted from local noise sources or other metallic objects, which can re-radiate noise and affect the tuning, radiation pattern and SWR, the better. Determine the direction you want the antenna to pivot and make sure there is adequate clearance (at least 65 feet).

Mounting Pipe

DX Engineering has a galvanized Chromolv Steel mounting mast available - Part Number **DXE-VGM'** Moly 4130 Steel Tubing, 100K PSI N Wall, 7 ft. Length,

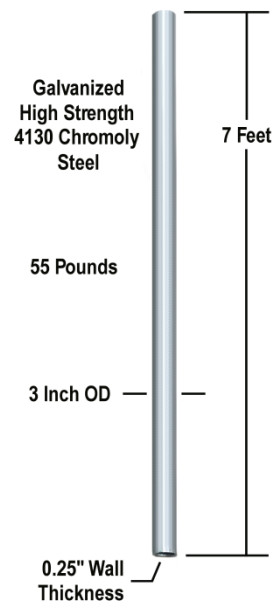

This mounting pipe must be permanently mounted in the ground, preferably in a concrete base 2 feet by 2 feet by 4 feet deep (with gravel below for drainage). The antenna system requires this type of mounting to help withstand the lateral forces present on the antenna during wind conditions and when operating the pivot function. Make the hole deep enough to accommodate at least 4 feet of pipe and 4 to 6 inches of gravel at the bottom for drainage. Set the mounting pipe on the gravel, use the concrete to fill around the pipe per the concrete instructions. Fill the hole until the concrete is level with the ground around it. Use a level on the mounting pipe as you fill the hole to be sure the mounting pipe is vertically straight.

Your location, landscape and ground conditions may require different mounting solutions in order to have the steel mounting pipe and the vertical antenna in a secure position.

Note: Galvanized steel, rather than aluminum, is much more suitable for mounting in concrete. Aluminum will quickly corrode due to incompatibility with the materials used to make concrete.

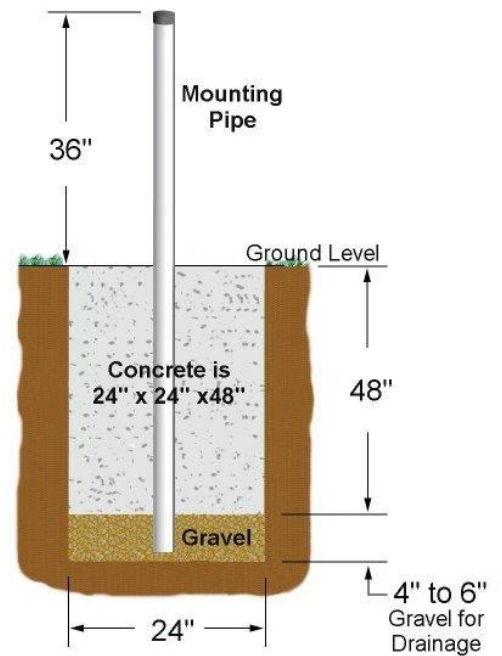

Coaxial Cable to Mounting Pipe

The coaxial cable should be routed to the base of the antenna system and be buried below the radial system. PVC Conduit pipe may be used to house the coaxial cable. Bury the cable 6" to 12" below ground level.

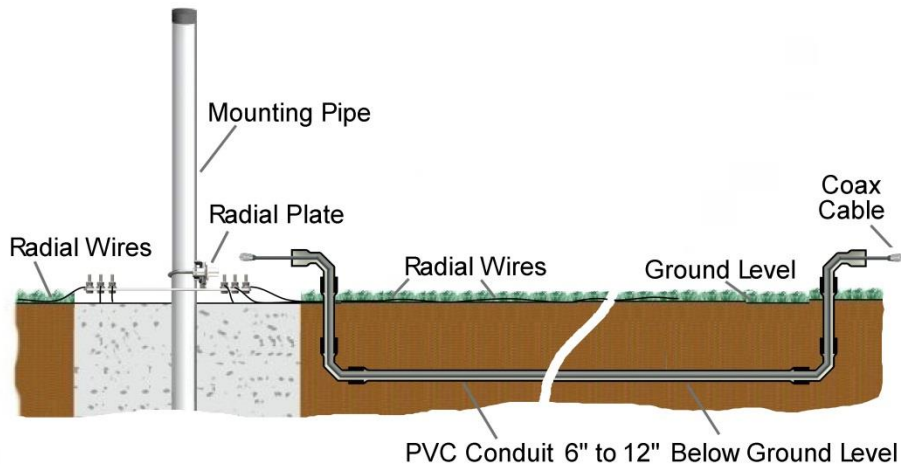

Radial System

The use of a radial system is a key requirement for a high performance quarter wave vertical antenna system. With a vertical antenna system, the radials are the second half of the antenna. The radials contribute to the radiation efficiency of the entire vertical antenna system.

At a minimum, 32 radials, each 65 feet long, should be used with this antenna. Longer radial wires, up to 135 feet each, would provide an improvement in signal strength for this 160 meter antenna. **DXE-RADW** Radial Wire is a 14 gauge stranded copper with black relaxed PVC insulation wire and is suggested for the best results. The wire radials should be placed as symmetrically as possible straight from the feedpoint around the vertical antenna and spaced evenly, regardless of how many radials are used. Do not cross or bunch any radial wires as this nullifies their effectiveness. If you have limited space, put in as many straight radials as you can. The radials must be connected to the shield of your feedline. The patented **DXE-RADP-3** Stainless Steel Radial Plate is an ideal optional item which provides an excellent system for attaching radial wires to your vertical antenna system.

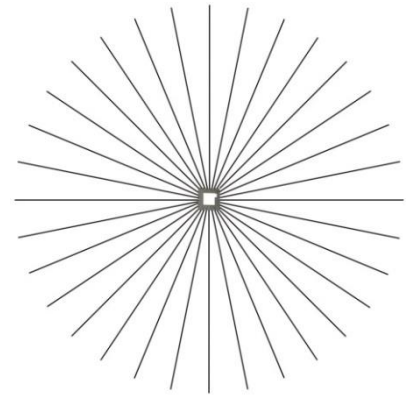

Radial wires can be laid on the roots of the grass using **DXE-STPL** Radial Wire Anchor Pins to hold them down. Using enough staples will ensure the wires will not be snagged by mowers, people, or animals. Grass will quickly overgrow the radials and it will be virtually impossible to see them. An article describing this process is available on the DX Engineering website in the **Tech Info** section. Radials can also be buried just under the surface by using a power edger to make a slit in the soil.

Assembly Notes

*Note: **JTL-12555 Jet-Lube™ SS-30 Anti-Oxidant** must be used between all antenna element sections. **Jet-Lube™ SS-30** is an electrical joint compound to affect a substantial electrical connection between metal parts such as **telescoping aluminum tubing** or other antenna pieces. It ensures high conductivity at all voltage levels by displacing moisture and preventing corrosion or oxidation.*

***Jet-Lube™ SS-30** must be used on all **element clamps and stainless steel threaded hardware** to provide good electrical contact, prevent galling, allows easier disassembly and to ensure proper tightening.*

Note: The following assembly instructions are based on using an optional **DXE-VGMT-3CG Mounting Pipe, with the optional **DXE-VR-1** Manual Winch, optional patented **DXE-RADP-3** Radial Plate and the optional **DXE-UHF-FDFB-KIT SecureMount™** Bulkhead Connector.**

Radial Plate to Mounting Pipe

Place the optional **DXE-RADP-3** Radial Plate over the optional **DXE-VGMT-3GC** 3" mounting pipe. Connections to the antenna will be made via the optional **DXE-UHF-FDFB-KIT** SecureMount™ bulkhead fitting dual SO-239 connector. The **DXE-RADP-3** Radial Plate comes with 20 sets of stainless steel hardware for mounting the radial wires. It is suggested that 32 radials each 65 feet long be used. Longer radial wires, up to 135 feet each, would provide an improvement in signal strength for this 160 meter antenna. Additional **DXE-RADP-1HWK** Radial Plate Wire Attachment Hardware Kits will be required.

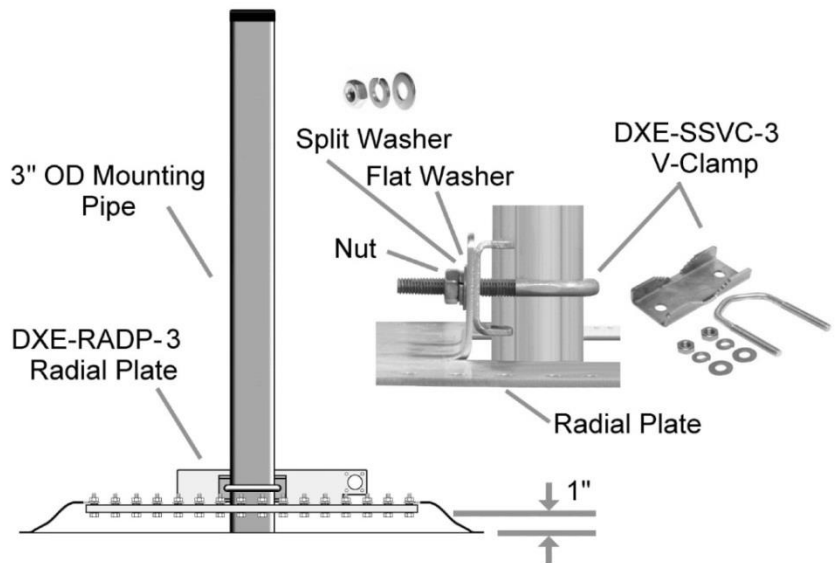

Optional DXE-RADP-3 Radial Plate Mounted to a 3" OD Mounting Pipe

Attaching Ground Radial Wires to the Radial Plate

Using the 20 sets of supplied 1/4" stainless steel hardware (Bolt, Star Washer, Flat Washer, Split Washer, Nut) connect the optional ground radial wires to the **DXE-RADP-3** Radial Plate as shown below. Additional hardware kits are available (**DXE-RADP-1HWK**) that contain 20 sets of Radial Plate Hardware.

There are optional DX Engineering Radial Wire Kits available. **DXE-RADW-500K/BD** contains a 500 foot spool of 14 gauge copper stranded wire with black PVC insulation, 20 Terminal Lugs and 100 Steel or Biodegradable Lawn Staples. The **DXE-RADW-1000K/BD** Radial Wire Kit contains a 1,000 foot spool of 14 gauge copper stranded wire with black PVC insulation, 40 Terminal Lugs and 200 Steel or Biodegradable Lawn Staples. **RADW-65RT** contains 20 each 65 foot radial wires with 1/4" terminal attached.

Depending on the number of radial wires used, space them out evenly around the Radial Plate. The Radial Plate will accommodate up to 60 radial wires (60 laser drilled holes), or up to 120 radials if doubled up.

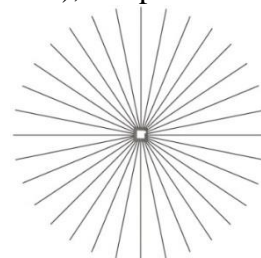
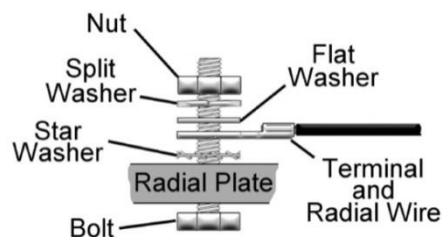

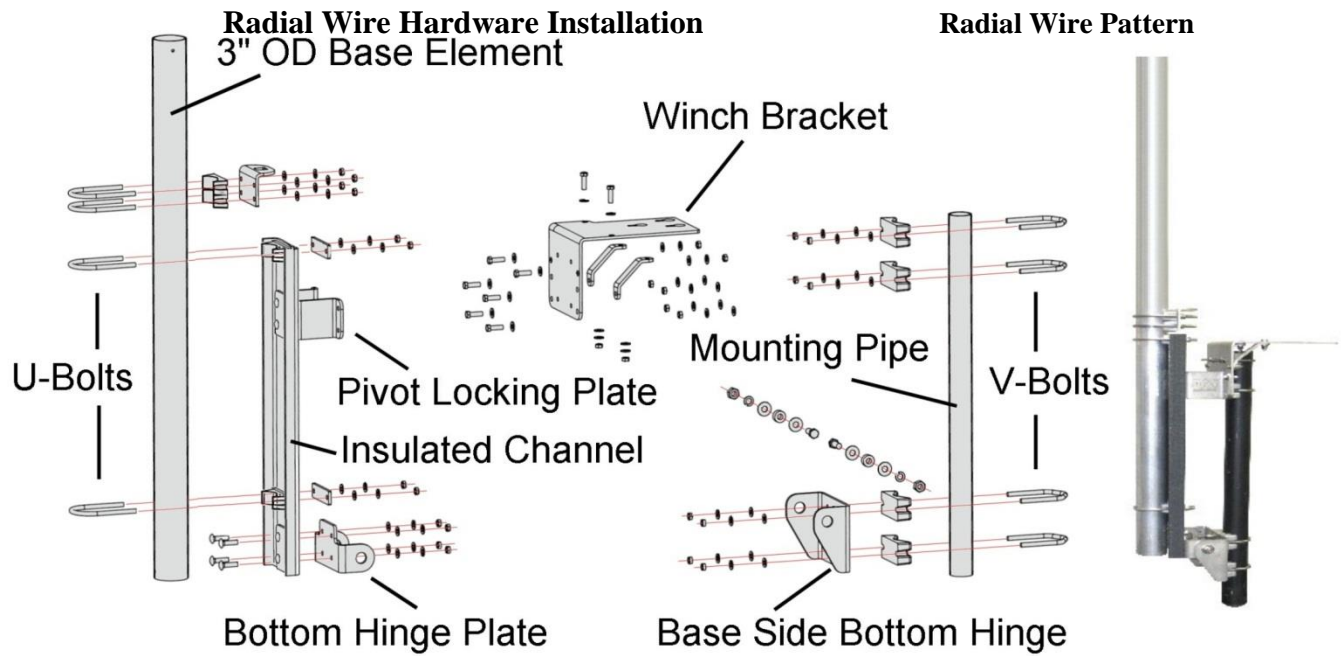

Overall Pivot Base (US Patent No. 8,130,168) Assembly Drawing

The exploded view drawing is for reference and shows the overall Pivot Base Assembly.
 (See **Parts List** for detailed drawing with numbered parts)

Pivot Base and Lower Antenna Assembly

1. Locate the heavy duty Extren[®] insulated channel.
 There are 12 holes drilled in the insulated channel.
 The top of the insulated channel is identified by two holes located very near the top end.



2. Locate the stainless steel bottom hinge plate, backing plate, four carriage bolts, four 3/8" flat washers, four 3/8" split lock washers and four 3/8" hex nuts. Assemble the bottom hinge to the bottom of the heavy duty insulated channel as shown below.

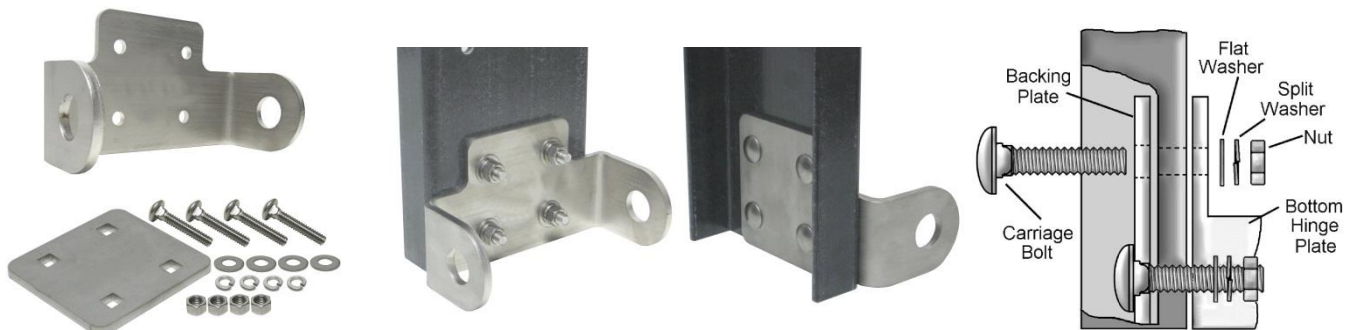

3. Locate the stainless steel pivot base locking plate, backing plate, four carriage bolts, four 3/8" flat washers, four 3/8" split lock washers and four 3/8" hex nuts. Assemble the pivot base locking plate to the top of the heavy duty insulated channel as shown below.

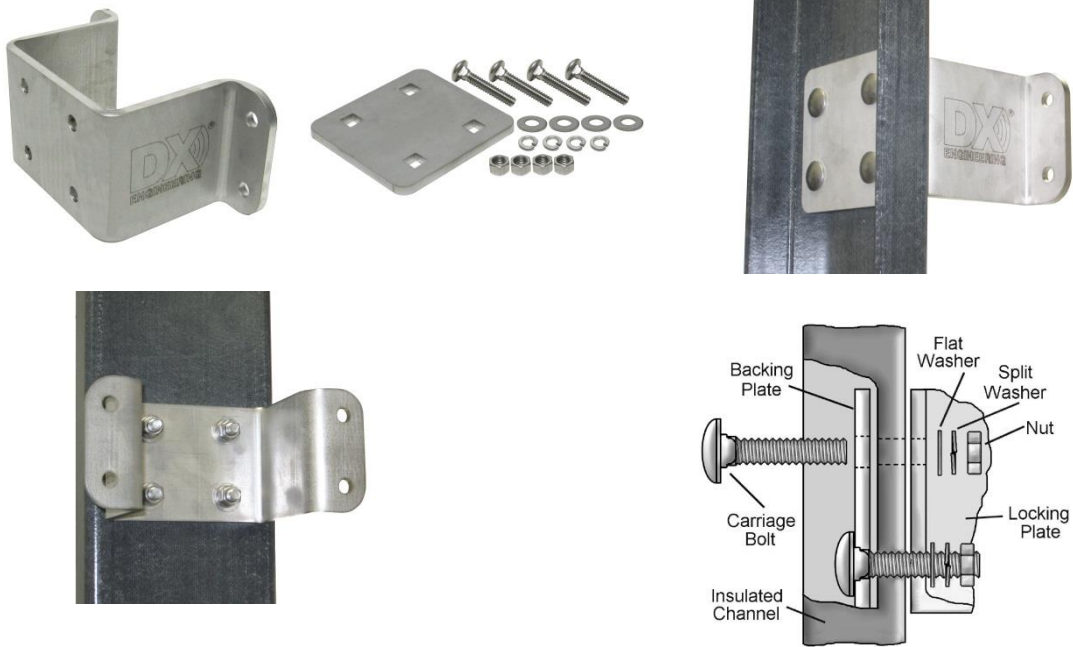

4. Locate the stainless steel base side bottom hinge, two 1/2-13 x 1-1/4" long stainless steel hex head bolts, two pivot bushings, four 1/2" x 1-1/4" stainless steel flat washers, two 1/2" stainless steel split lock washers, and two 1/2-13 stainless steel hex nuts. Assemble the base side hinge plate to the bottom hinge plate as shown below.

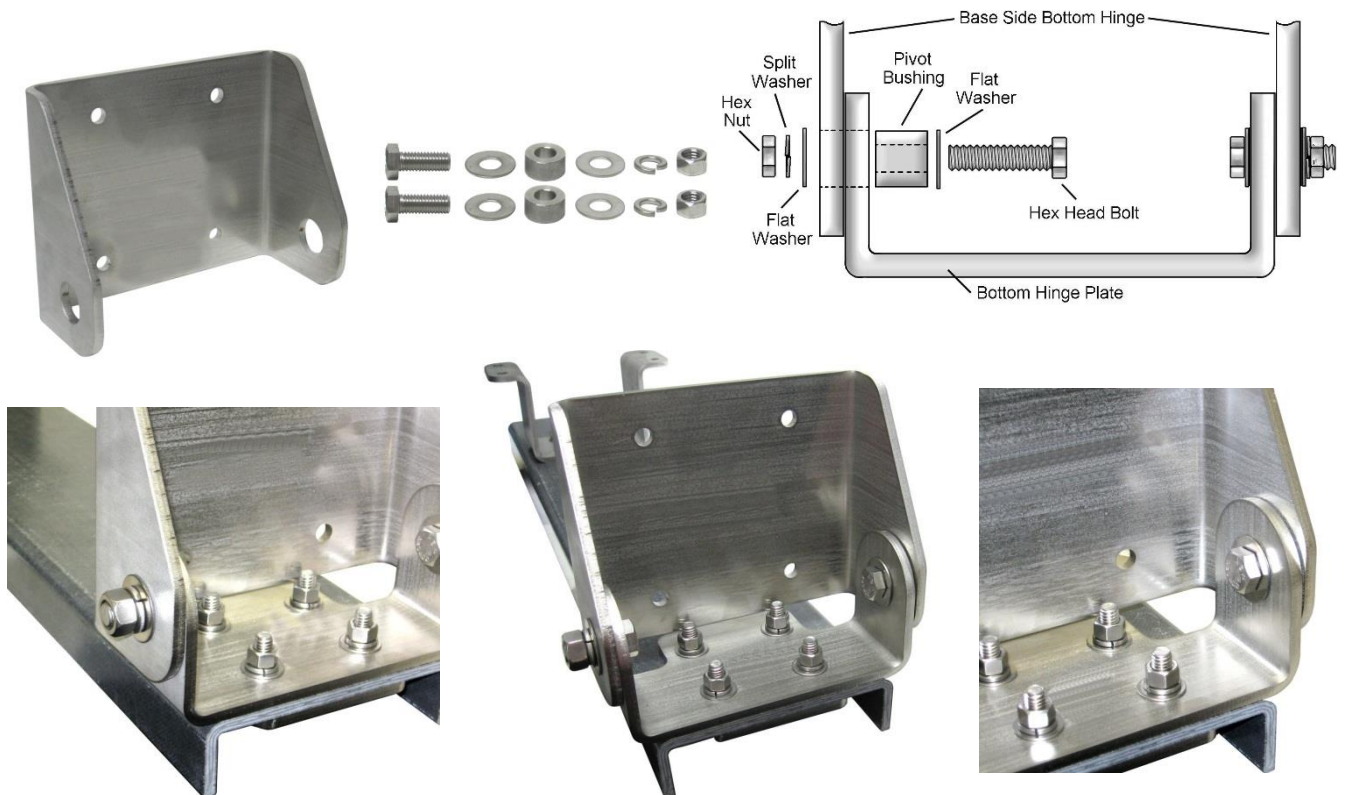

- Locate two V-Saddle blocks, two stainless steel V-Bolts, four stainless steel 3/8" flat washers, four stainless steel 3/8" split lock washers and four stainless steel 3/8-16 hex head nuts. Loosely assemble (one or two threads beyond the end of the hex nuts) the two V-Bolts to the stainless steel base side bottom hinge as shown below. The V-Bolts will be tightened in a later assembly step.

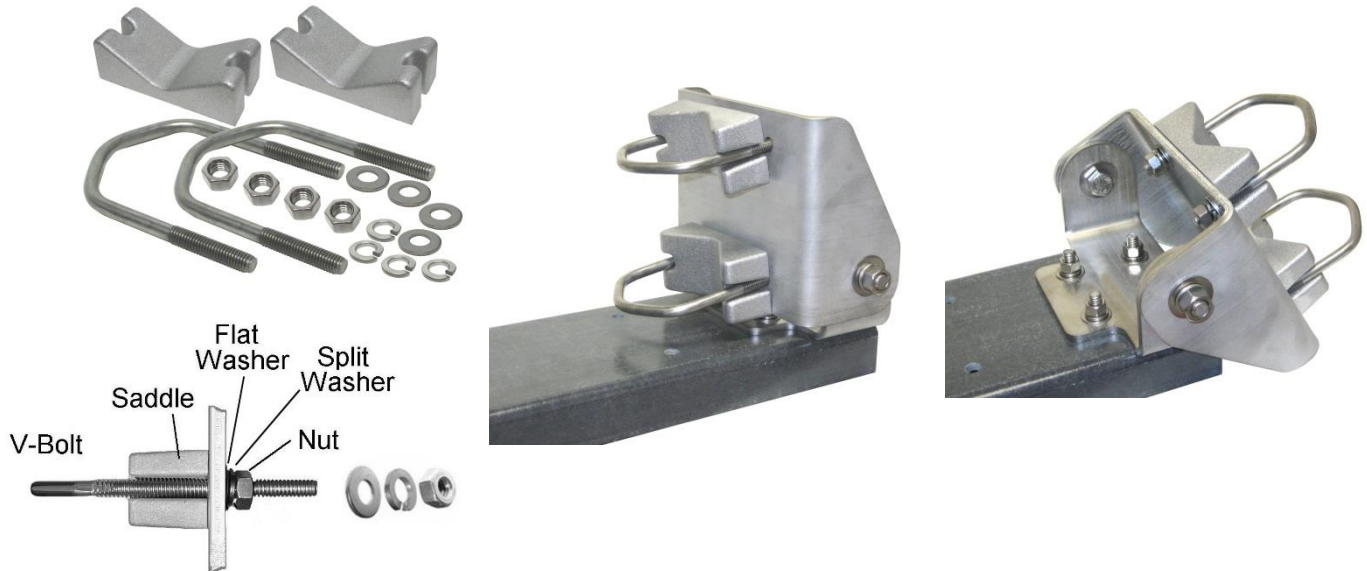

- Locate the stainless steel Pivot Base Winch Mount, two stainless steel Pivot Base Plate Brackets, four 3/8-16 x 1-1/4" long stainless steel hex bolts, eight stainless steel 3/8" flat washers, four stainless steel 3/8" split lock washers and four stainless steel 3/8-16 hex nuts. Assemble the Pivot Base Plate Brackets to the Pivot Base Winch Mount as shown below.

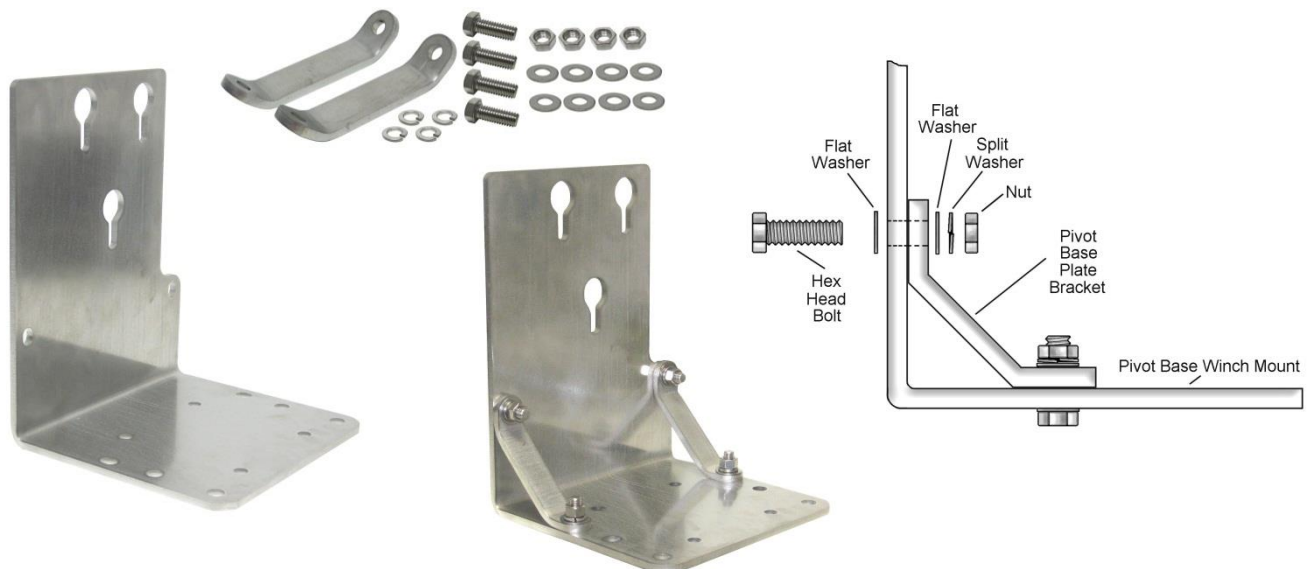

- Locate four 3/8-16 x 1-1/4" long stainless steel hex bolts, eight stainless steel 3/8" flat washers, four stainless steel 3/8" split lock washers and four stainless steel 3/8-16 hex nuts. Mount the Pivot Base Winch Mount assembly to the stainless steel Pivot Base Locking Plate.

Note: These four bolts are removed when using the pivoting function as described later on in this manual.

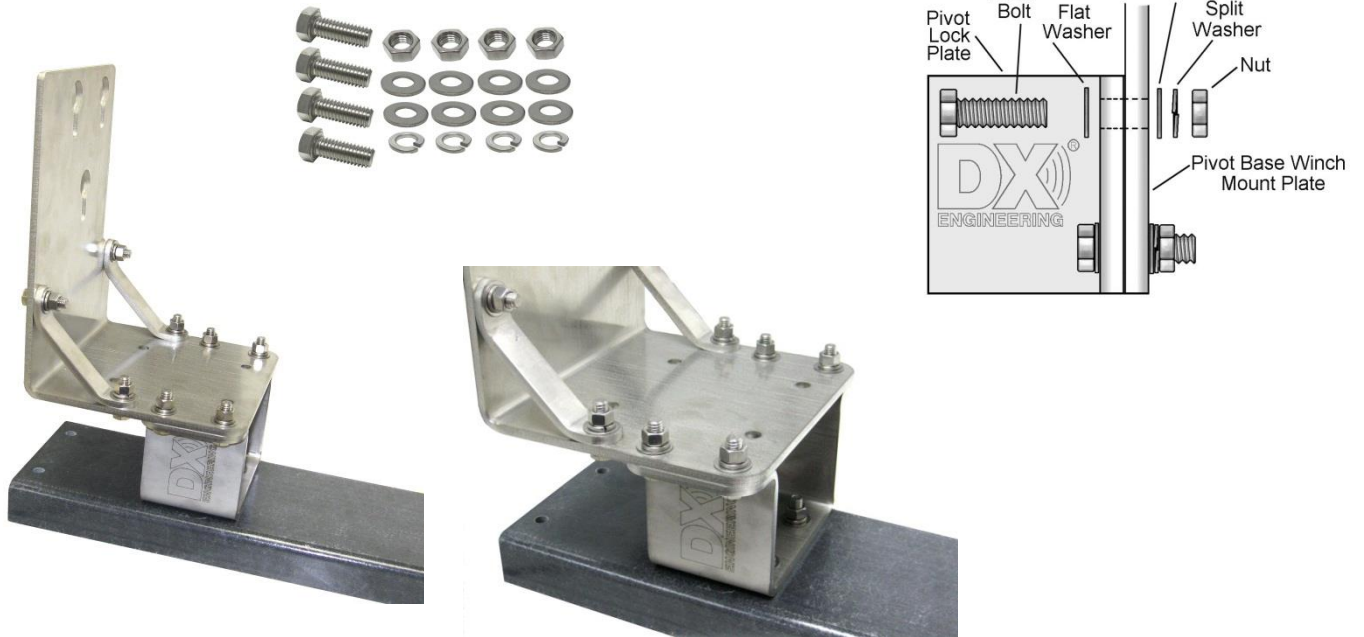

- Locate two V-Saddle blocks, two stainless steel V-Bolts, four stainless steel 3/8" flat washers, four stainless steel 3/8" split lock washers and four stainless steel 3/8-16 hex head nuts. Loosely assemble (one or two threads beyond the end of the hex nuts) the two V-Bolts to the stainless steel Pivot Base Winch Mount as shown below. The V-Bolts will be tightened in a later assembly step.

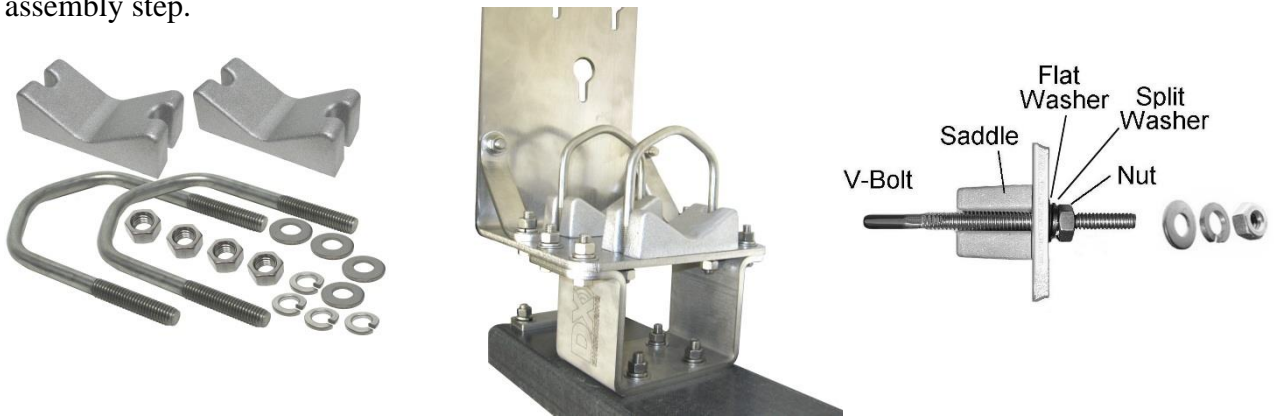

- Locate two thick stainless steel Backing Plates, two thin stainless steel Backing Plates, two U-Bolt Saddle blocks, two stainless steel U-Bolts, four stainless steel 3/8" flat washers, four stainless steel 3/8" split lock washers and four stainless steel 3/8-16 hex head nuts.

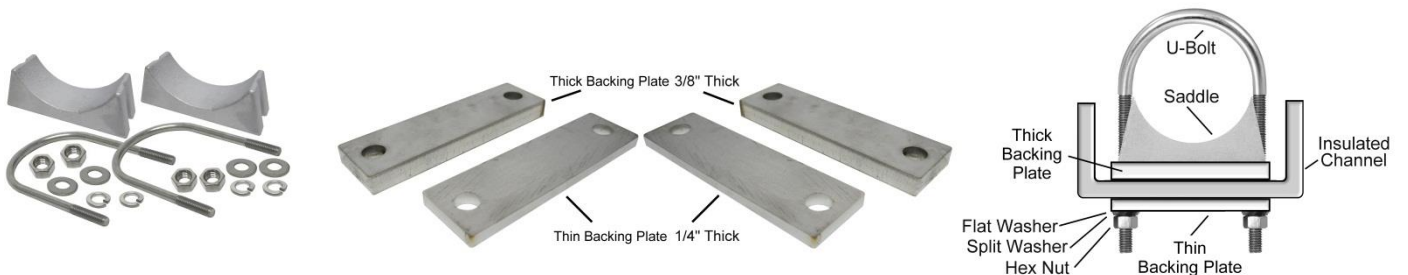

The two Thick Backing Plates (3/8") are located next to the U-Bolt Saddles on the inside of the insulated channel. The two Thin Backing Plates (1/4") are used on the rear side of the insulated channel.



**Top of Insulated Channel
Showing U-Bolt installed
The Thick Spacer is on the front side
The Thin Spacer is on the rear side**



**Rear and Front views showing the U-Bolt located
at the Bottom of the Insulated Channel
The Thick Spacer is on the front side, the
Thin Spacer is on the rear side**



Loosely assemble (one or two threads beyond the end of the hex nuts) the two U-Bolts and associated hardware to the insulated mounting channel as shown above. The U-Bolts will be tightened in a later assembly step.

10. Move the four V-Bolts out as far as they will go (these were put on loosely in steps 2 and 8).

Slide the entire assembly onto your mounting pipe. **You want approximately 1 inch clearance from the top of your mounting pipe to the bottom side of the winch mounting plate.** Position the base fixture in the position you pre-selected for the pivoting direction. Make sure the assembly is vertical and there is no tilt between the top and bottom.

Tighten the V-Bolt clamp hardware evenly so the length of the exposed threads is approximately equal. Any clamp should be tightened evenly from side-to-side with an equal amount of thread above each nut.

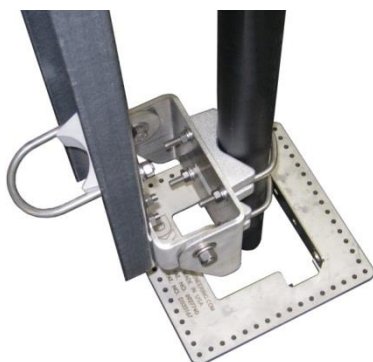

11. Locate the 3" OD x 72", 0.120" wall thickness antenna bottom element section. There are 5 holes drilled in this element section.

One drilled hole at the bottom is for the feedpoint hardware.

Four drilled holes at the top are used for mating to the next antenna element section.



Loosen the previously installed U-Bolts (**Step 9**). Insert the 72" Antenna Bottom Element Section into the antenna base section through the upper and lower U-Bolts.

Position the single feedpoint hole at the bottom facing outward as shown in the picture to the right.

The bottom of the 3" OD element tube should be even with the bottom of the insulated channel as shown below.

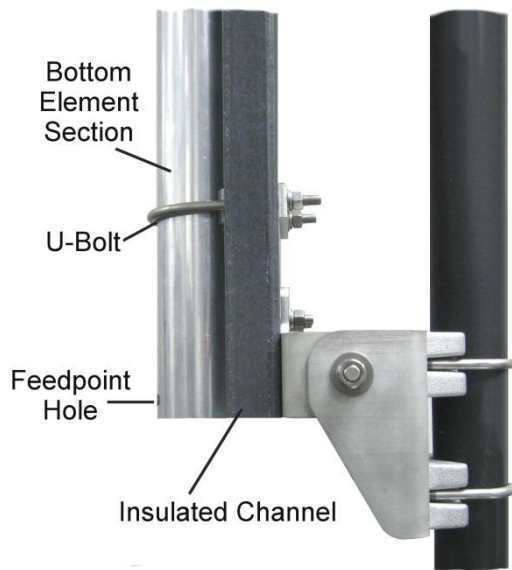

Side View



Front View

Tighten the lower and upper U-Bolt clamps hardware evenly so the length of the exposed threads is approximately equal. Any clamp should be tightened evenly from side-to-side with an equal amount of thread above each nut.

12. Locate the stainless steel Antenna Hook Mounting Plate, two U-Bolt Saddle blocks, two stainless steel U-Bolts, four stainless steel 3/8" flat washers, four stainless steel 3/8" split lock washers and four stainless steel 3/8-16 hex head nuts.

Loosely assemble (one or two threads beyond the end of the hex nuts) the two U-Bolts and associated hardware to the antenna hook mounting plate as shown below. The U-Bolts will be tightened in the next assembly step.

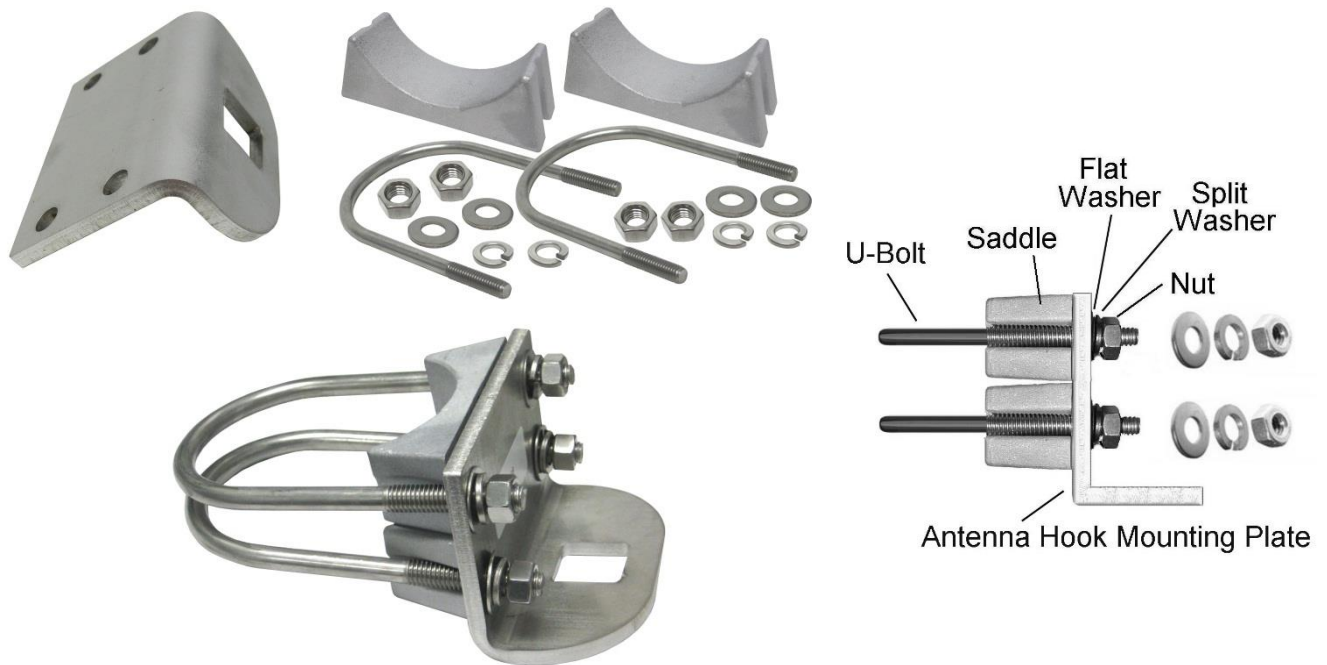

13. Loosen the U-Bolts enough to slide the Antenna Hook Mount assembly over the 3" OD antenna lower element on the base assembly. Position the antenna hook mount approximately 1/2" above the insulated channel as shown below.

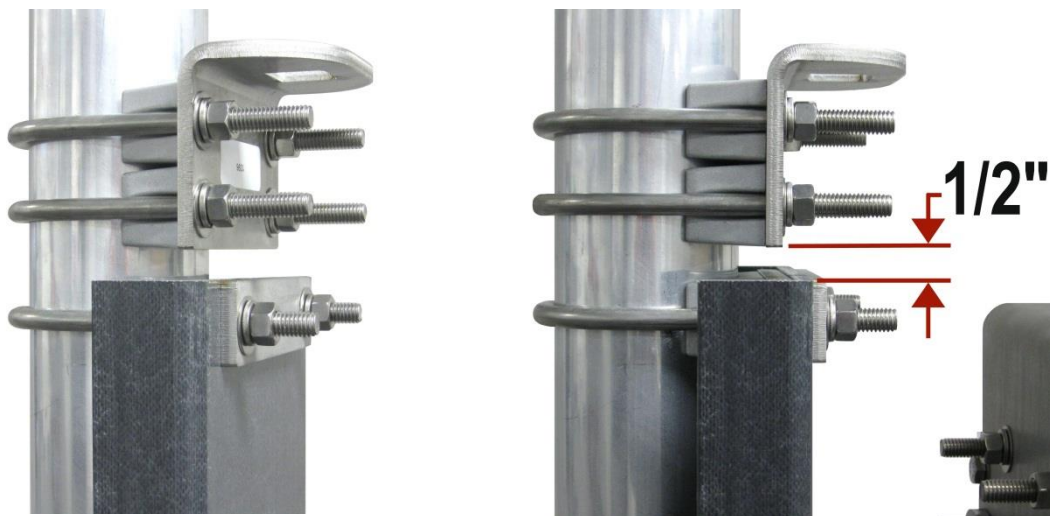

14. Tighten the two U-Bolt clamps hardware evenly so the length of the exposed threads is approximately equal. Any clamp should be tightened evenly from side-to-side with an equal amount of thread above each nut.
15. Locate the 1/4-20 x 1.25" long stainless steel hex bolt, two 1/4" stainless steel external tooth lock washers, one 1/4" stainless steel flat washer and one stainless steel 1/4-20 hex nut. Install the feedpoint hardware at the bottom of the 3" OD bottom element in the pre-drilled hole as shown below.

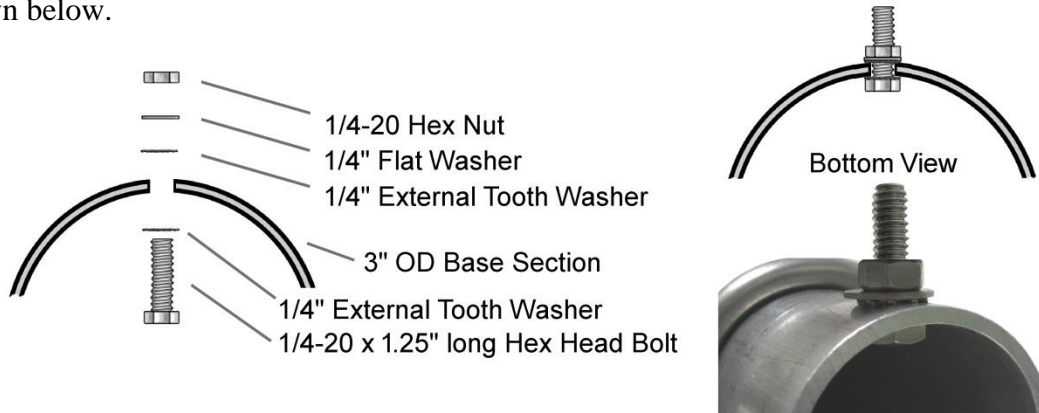

View showing the feedpoint hardware installed

Mounting and using the Optional DXE-VRW-1 Manual Winch

1. Follow the instructions included with the optional **DXE-VRW-1 - Manual Winch Add-On Kit** to prepare the Manual Winch for installation on the antenna base assembly.
2. Included with optional **DXE-VRW-1 - Manual Winch Add-On Kit** is the stainless steel hardware for mounting the winch on the pivot base assembly. The hardware includes three 3/8-16 x 1" long stainless steel hex bolts, six stainless steel 3/8-16 flat washers and three 3/8-16 Stainless Steel Nyloc Nuts. 
3. Loosely install the three sets of stainless steel hardware on the manual winch as shown below.

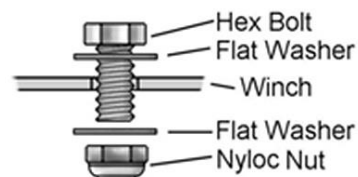
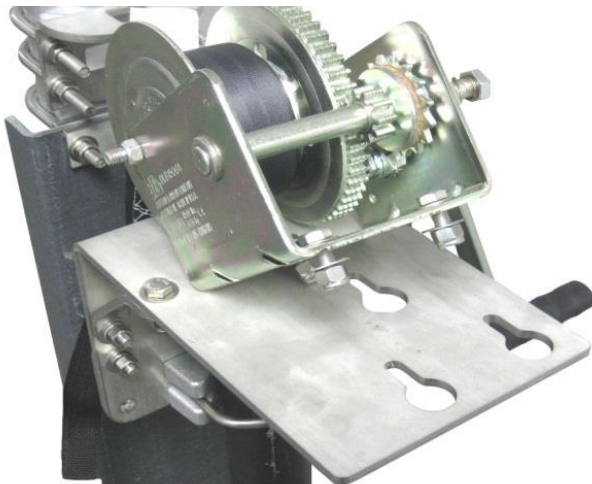

4. The hardware does not have to be removed from the manual winch to either install or remove the manual winch from the winch mounting plate.
5. There are three holes with slots in the mounting bracket. The flat washers will fit through the large holes. Once in place, push the winch inward (toward the antenna elements) allowing the three bolts to go into the three slots. Tighten the hardware to hold the winch in place.

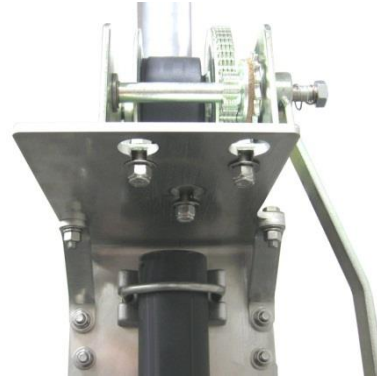
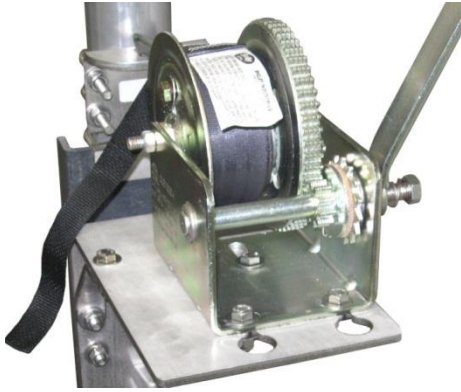

6. Connect the Hook from the manual winch strap to the Antenna Hook Mount as shown below. Crank the strap so it is snug and not loose.



To remove the winch, simply reverse this sequence.

The manual winch should be removed and stored when not in use to protect the gears and web strap from weather and environmental effects.

7. To lower the antenna, ensure the winch hook is in the Antenna Hook Mount and the winch is wound up snug so the antenna will not move. Remove the four bolts and hardware that hold the Pivot Lock Plate to the Pivot Base Winch Mount Plate. You can now use the winch to pivot the antenna downward.

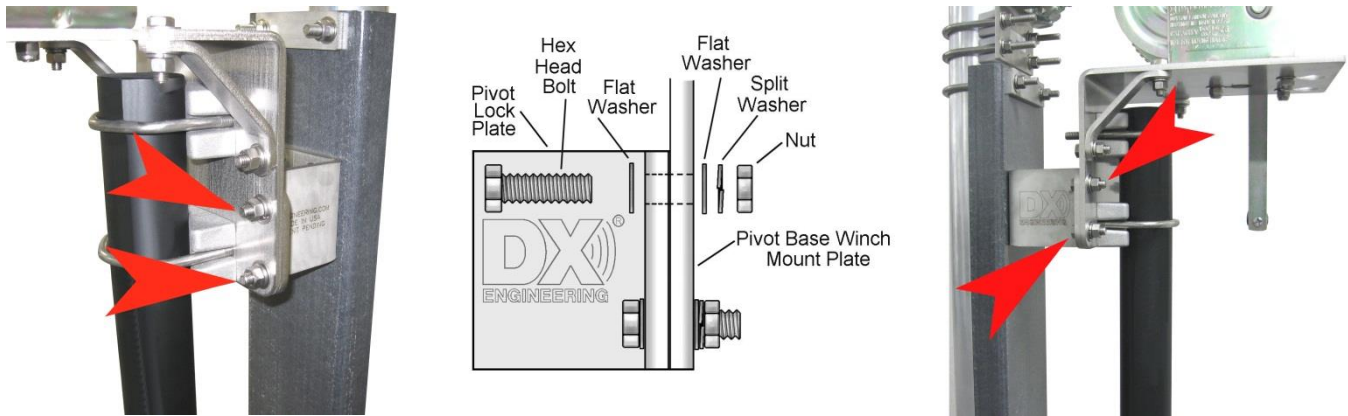

Four Bolts to be removed to allow for pivoting

8. Turn the crank on the manual winch to lower, or raise the antenna. After raising the antenna completely, make sure you replace the four bolts that were removed in step 3. The manual winch should be removed and stored when not in use to protect the gears and web strap from weather and environmental effects.



Note: Sawhorses, chairs, or ladders should be used to support the vertical sections during assembly with the pivot base and whenever the vertical is tilted down to allow easy maintenance, or when making adjustments.

General Information about Aluminum Tubing

*Note: **JTL-12555 Jet-Lube™ SS-30 Anti-Oxidant must be used between all antenna element sections. Jet-Lube™ SS-30 is an electrical joint compound to affect a substantial electrical connection between metal parts such as **telescoping aluminum tubing** or other antenna pieces. It ensures high conductivity at all voltage levels by displacing moisture and preventing corrosion or oxidation.***

*Jet-Lube™ SS-30 must be used on all **element clamps and stainless steel threaded hardware** to provide good electrical contact, prevent galling, allowing easier disassembly and to ensure proper tightening.*

When assembling any telescoping aluminum tubing sections you should take the following steps:

1. Make sure the edges are smooth and not sharp. Deburring may be necessary, since burrs and shavings can occur on seams as well as edges. All surfaces need to be completely smooth to allow easy assembly of tubing sections.

Caution

*Aluminum tubing edges can be very sharp.
Take precautions to ensure you do not get accidentally cut.*

The raised particles and shavings that appear when the aluminum tubing is machined are referred to as burrs, and the process by which they are removed is known as deburring.

Deburring is a finishing method used in manufacturing. DX Engineering aluminum tubing is machine cut on both ends and may have machine slits on one end, you should further assure there are no ragged edges or protrusions.

Use the **DXE-22166 Slim Grip Deburring Tool**, or the **DXE-22600 Deburring Tool with Extending Handle and Extra Blades** for this operation.

2. Clean the inside of the aluminum tubing to clear out any dirt or foreign material that would cause the aluminum tubing sections to bind during assembly. Do not use any type of oil or general lubricant between the aluminum tubing sections. Oils or general lubricants can cause poor electrical connections for radio frequencies.
3. Clean the outside of the aluminum tubing to clear any dirt or foreign material that would cause the clamps to malfunction during assembly.
4. When assembling the aluminum tubing sections, ensure the area is clear of grass, dirt or other foreign material that could cause problems during assembly of the closely fitted telescoping sections.

Assembling the Vertical Sections











The vertical sections of the **DXE-160VA-1** is made of custom engineered 6061-T8 and 6063-T832 corrosion-resistant aluminum tubing ranging in size from 3" OD to 1" OD. The 3" OD section has already been mounted in the Pivot Base Assembly in an earlier assembly step.

Topping off the installation of the vertical sections will be the Capacity Hat assembly which is specifically designed to allow the center of resonance to be moved down to the low band edge of 160 meters for dedicated CW ops.

It is suggested that the vertical elements be laid out in a line according to size on a flat surface for ease of assembly. Once all the parts are assembled, the vertical sections should be supported with either saw horses, chairs or other suitable structures for installation of the capacity hat.

When all the vertical element sections are assembled, they will be mated to the Pivot Base Assembly.

DXE-160VA-1 Element Tube Sections

	1" OD x 72" Long, .058 Wall Thickness Slits on one end
	1.125" OD x 72" Long, .058 Wall Thickness Slits on one end
	1.25" OD x 72" Long, .058 Wall Thickness Slits on one end
	1.5" OD x 72" Long, .120 Wall Thickness Slits on both ends
	1.75" OD x 72" Long, .120 Wall Thickness Slits on one end
	2" OD x 72" Long, .120 Wall Thickness 4 Drilled Holes one end Slits on one end
	2.25" OD x 72" Long, .120 Wall Thickness 8 Drilled Holes
	2.5" OD x 72" Long, .120 Wall Thickness 8 Drilled Holes
	2.75" OD x 48" Long, .120 Wall Thickness 8 Drilled Holes
	3" OD x 72" Long, .120 Wall Thickness 1 Drilled hole for Feedpoint 4 Drilled Holes one end

Note: The 3" OD x 72" long, .120" wall thickness base antenna section has already been installed on the Pivot Base Assembly.

1. Locate the following hardware:

QTY	Description
2	1/4" x 2-34" long Stainless Steel Hex Head Bolt
2	1/4" x 3" long Stainless Steel Hex Head Bolt
2	1/4" x 3-1/4" long Stainless Steel Hex Head Bolt
12	1/4" Stainless Steel Flat Washer
6	1/4" Stainless Steel Nyloc Hex Nut



2. The diagram to the right is an overall layout of all the vertical elements with hardware for reference.

The 3" OD element which is already mounted on the base pivot assembly is shown for reference. The 3-1/2" bolts and hardware will be used in a later step (page 26).

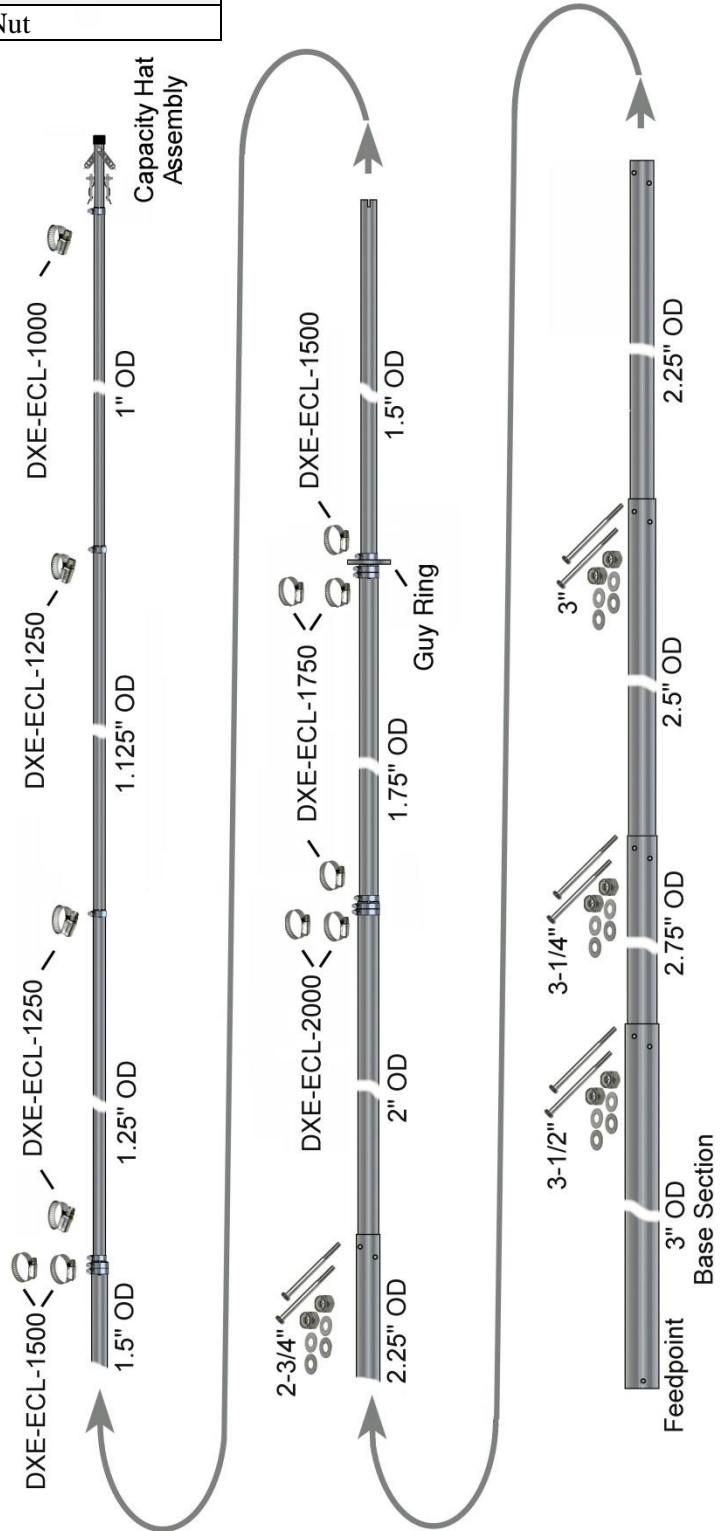

- Assemble the 2.5" OD element to the 2.75" OD element using the two stainless steel 3-1/4" long 1/4" bolts, four stainless steel flat washers and two 1/4" stainless steel Nyloc nuts as shown below. Make sure you insert the 2.5" OD tube into the correct end of the 2.75" OD section - the holes at each end are drilled differently. When tightening the bolt and Nyloc nut, tighten them enough to hold, but not tight enough to deform the aluminum elements.

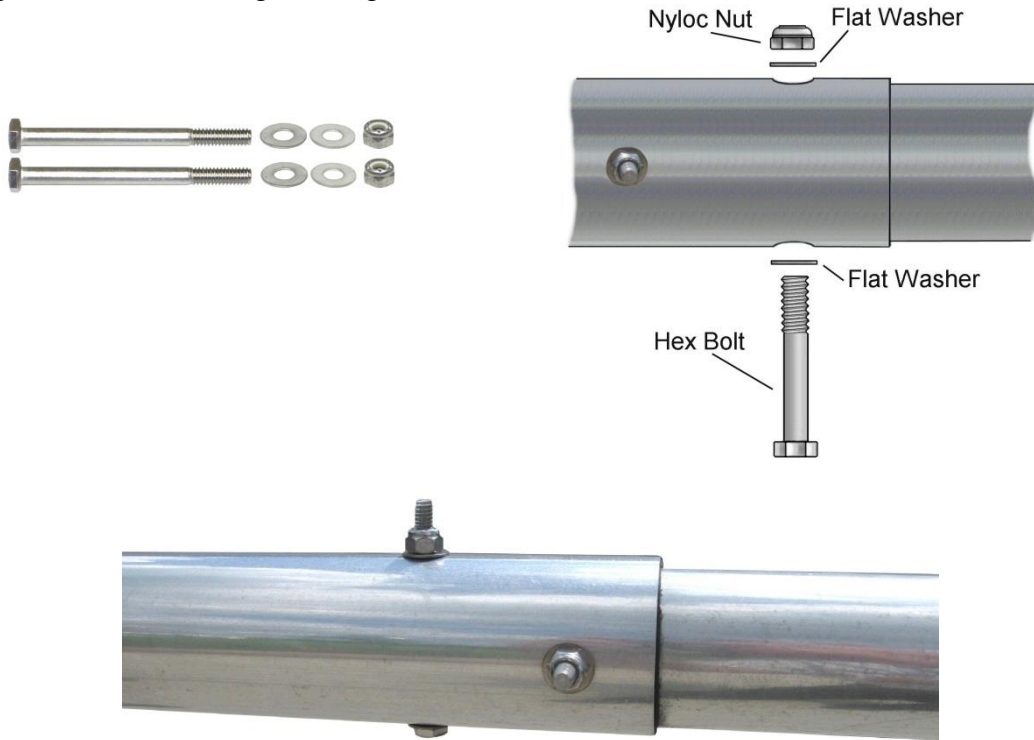

The following drilled sections are drilled to match the next size, so make sure you have the correct ends matched up (holes aligned).

- Repeat the above step to mate the 2.5" OD element to the 2.25" OD element using the 3" long 1/4" bolts and hardware.
- Repeat the above step to mate the 2.25" OD element to the 2" OD element using the 2-3/4" long 1/4" bolts and hardware.

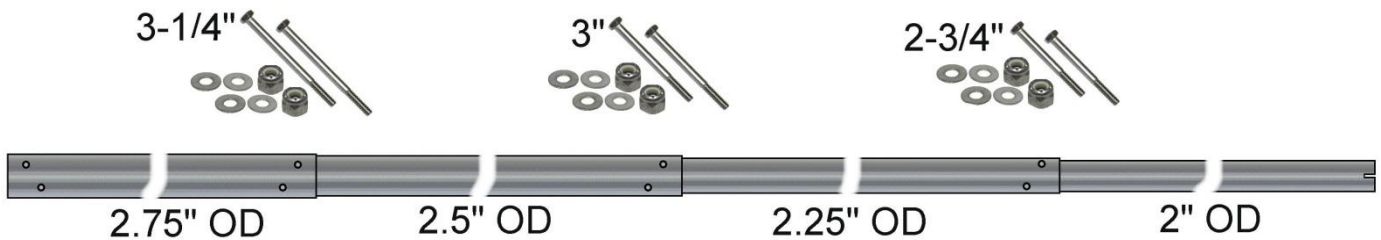

6. Using a tape measure and felt tip pen, mark a line 4" (on the end opposite the slits) on the 72" long tubes (1.125", 1.25", 1.5" and 1.75" OD tubes) and 12" on the 1" OD Tube. Note the 1.5" OD tube has slits on both ends so it does not matter which end you mark.

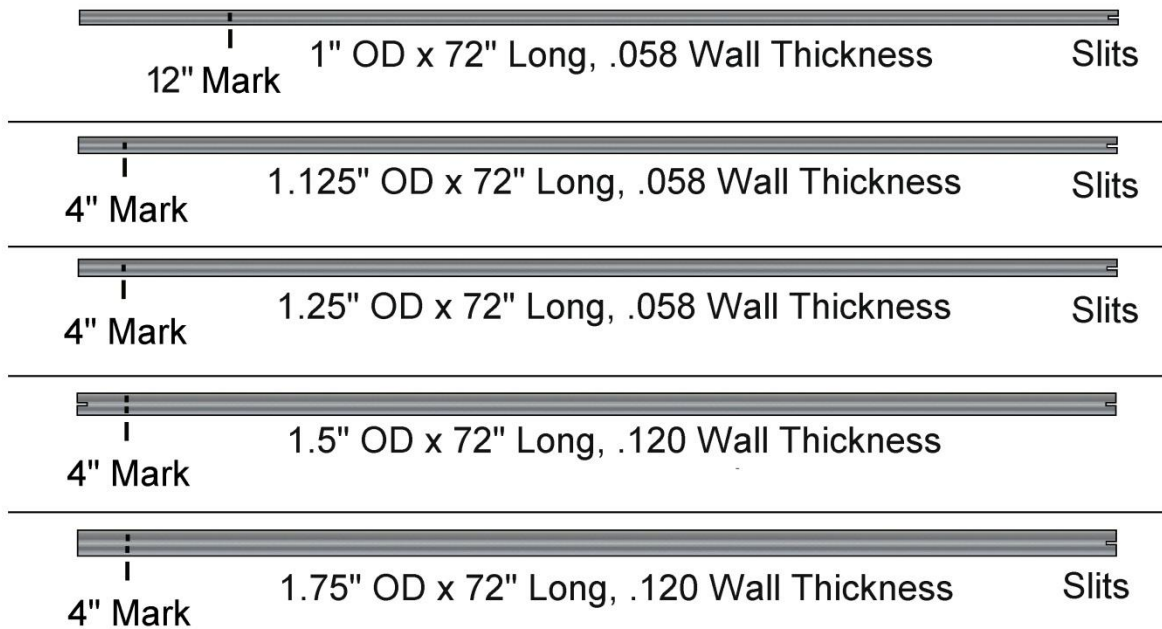

7. The five slit element tubes are installed using Stainless Steel Element Clamps. The drawing below shows the exposed lengths for reference.

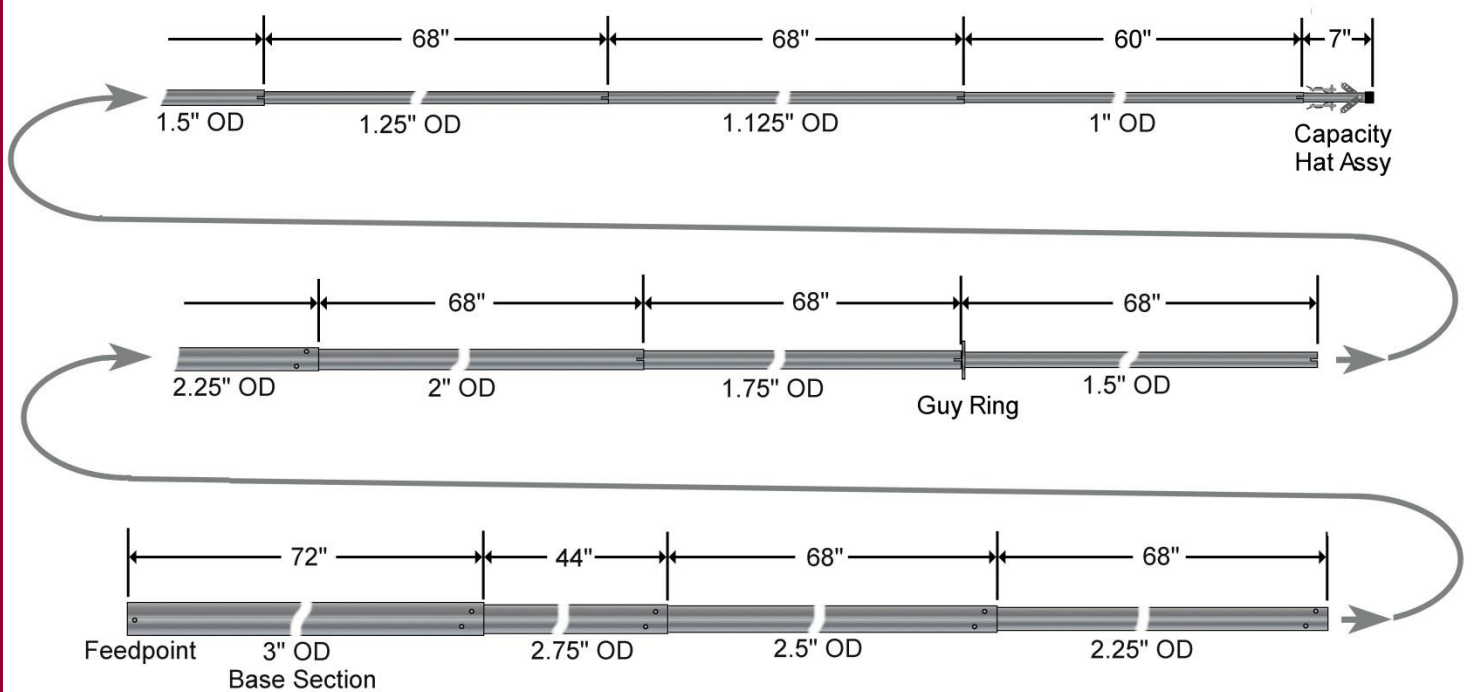

The reference drawing below shows the hardware used for joining the element tubes.

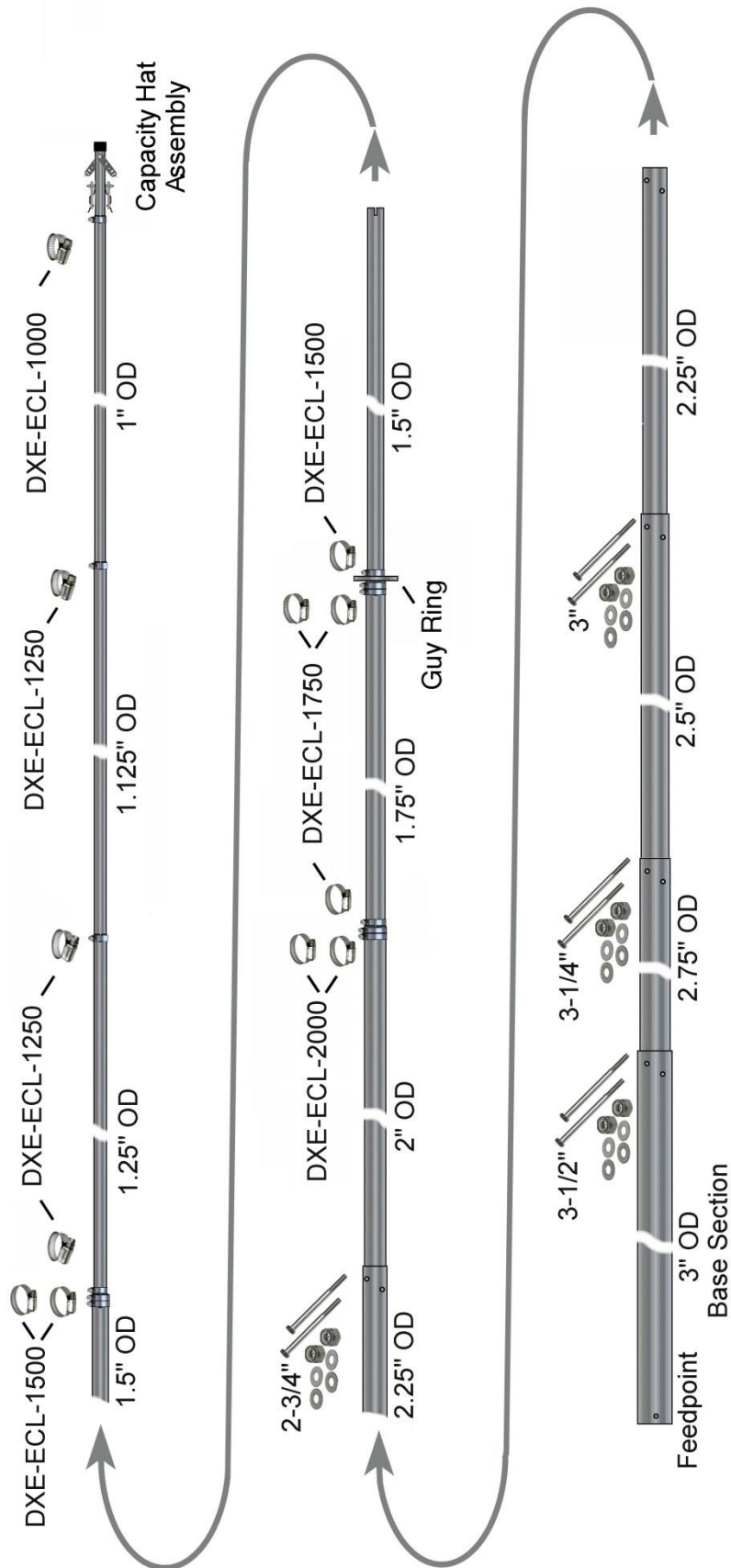

8. Locate two **DXE-ECL-2000** Stainless Steel Element Clamps, one **DXE-ECL-1750** Stainless Steel Element Clamp and the 1.75" OD x 72" element tube that was marked in step 7.

Slide the two **DXE-ECL-2000** element clamps over the 2" OD element. Slide the one **DXE-ECL-1750** element clamp over the 1.75" OD element. Slide the 1.75" OD element inside the 2" OD element tube to the mark made at 4". Tighten the two **DXE-ECL-2000** clamps in place. Do not over-tighten which may cause clamp damage. This element tubing joint uses a second clamp to ensure proper element position. Slide the **DXE-ECL-1750** next to the joint between the 2" OD element tube and 1.75" OD element tube. Tighten the clamp in place. This third clamp ensures that the 1.75" section cannot slip further inside the 2" OD section.

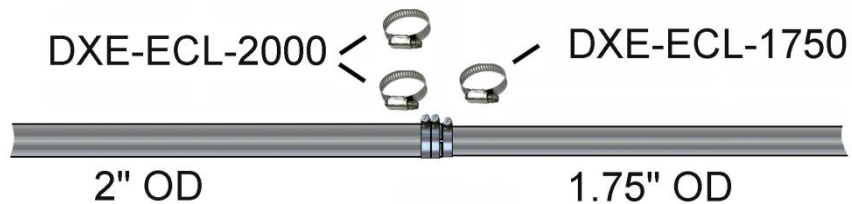

9. Locate the aluminum Guy Ring, two **DXE-ECL-1750** Stainless Steel Element Clamps, one **DXE-ECL-1500** Stainless Steel Element Clamp and the 1.5" OD x 72 long element.

Slide the two **DXE-ECL-1750** clamps over the 1.75" OD element tube. Slide the Guy Ring and the **DXE-ECL-1500** clamp over the 1.5" OD element tube. Tighten the two **DXE-ECL-1750** clamps in place. Do not over-tighten which may cause clamp damage. Slide the Guy Ring next to the joint between the 1.75" OD element tube and 1.5" OD element tube. The **DXE-ECL-1500** clamp is then snugged up next to the Guy Ring and tightened in place.

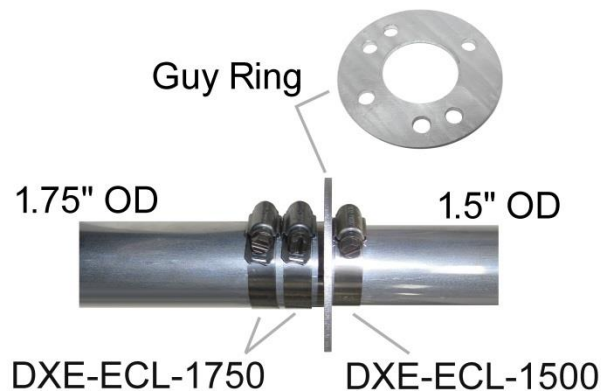

10. Locate two **DXE-ECL-1500** Stainless Steel Element Clamps, one **DXE-ECL-1250** Stainless Steel Element Clamp and the 1.25" OD x 72" element tube that was marked in step 7.

Slide the two **DXE-ECL-1500** element clamps over the 1.5" OD element tube. Slide the one **DXE-ECL-1250** element clamp over the 1.25" OD element tube. Slide the 1.25" OD element tube inside the 1.5" OD element tube to the mark made at 4". Tighten the two **DXE-ECL-1500** clamps in place. Do not over-tighten which may cause clamp damage. This tubing joint uses a second clamp to ensure proper element position. Slide the **DXE-ECL-1250** next to the joint between the 1.5" OD element tube and 1.25" OD element tube. Tighten the clamp in place. This third clamp ensures that the 1.25" section cannot slip further inside the 1.5" OD section.

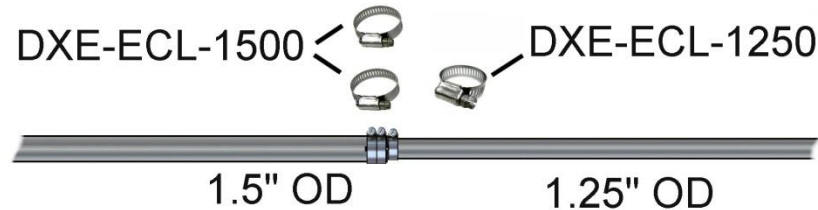

11. Locate the **DXE-ECL-1250** Stainless Steel Element Clamp and the 1.125" OD x 72" element tube that was marked in step 7. Slide the **DXE-ECL-1250** element clamp over the 1.125" OD element tube. Slide the 1.125" OD element inside the 1.25" OD element tube to the mark made at 4". Tighten the **DXE-ECL-1250** clamp in place. Do not over-tighten which may cause clamp damage.



12. Locate the **DXE-ECL-1250** Stainless Steel Element Clamp, the 1" OD x 72" element tube that was marked in step 7. Slide the **DXE-ECL-1250** element clamp over the 1.125" OD element tube. Slide the 1" OD element inside the 1.125" OD element to the mark made at 12". Tighten the **DXE-ECL-1250** clamp in place. Do not over-tighten which may cause clamp damage.

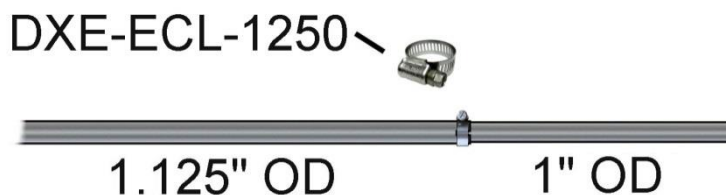

13. The Capacity Hat assembly will be mounted on the 1" OD element tube in a later step.

Mating the Vertical Element to the Pivot Base Assembly

1. To lower the antenna, ensure the winch hook is in the Antenna Hook Mount. Remove the four bolts and hardware that hold the Pivot Lock Plate to the Pivot Base Winch Mount Plate. You can now use the winch to pivot the antenna downward.

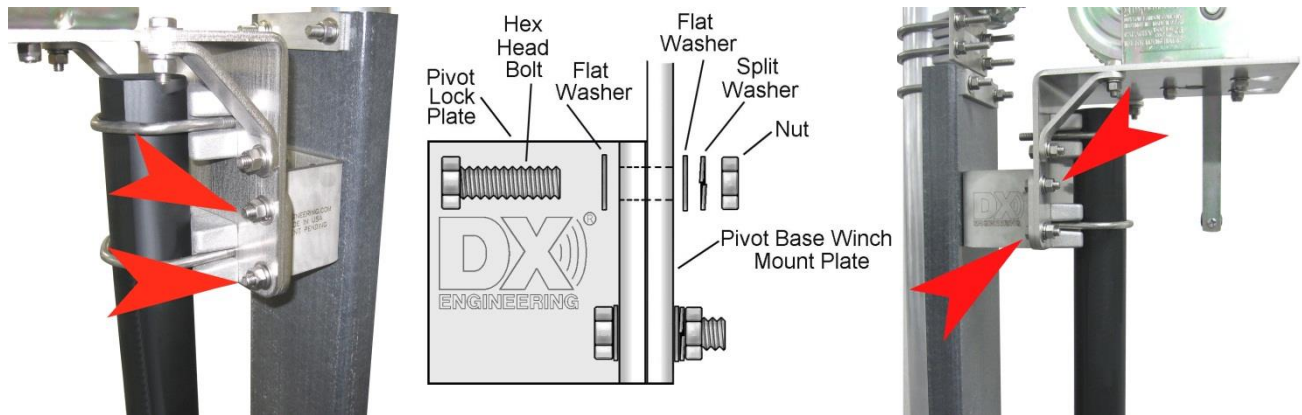

Four Bolts to be removed to allow for pivoting



2. Locate the 3-1/2" long 1/4" bolts, four stainless steel flat washers and two 1/4" stainless steel Nyloc nuts. Align the 3" OD base section element with the assembled vertical elements. Slide the 2.75" element section into the 3" OD base element section aligning the 4 holes.



3. Assemble the 2.75" OD element tube to the 3" OD element tube (installed on the Extren[®] insulated channel) using the two stainless steel 3-1/2" long 1/4" bolts, four stainless steel flat washers and two 1/4" stainless steel Nyloc nuts as shown below. When tightening the bolt and Nyloc nut, tighten them enough to hold, but not tight enough to deform the aluminum elements.

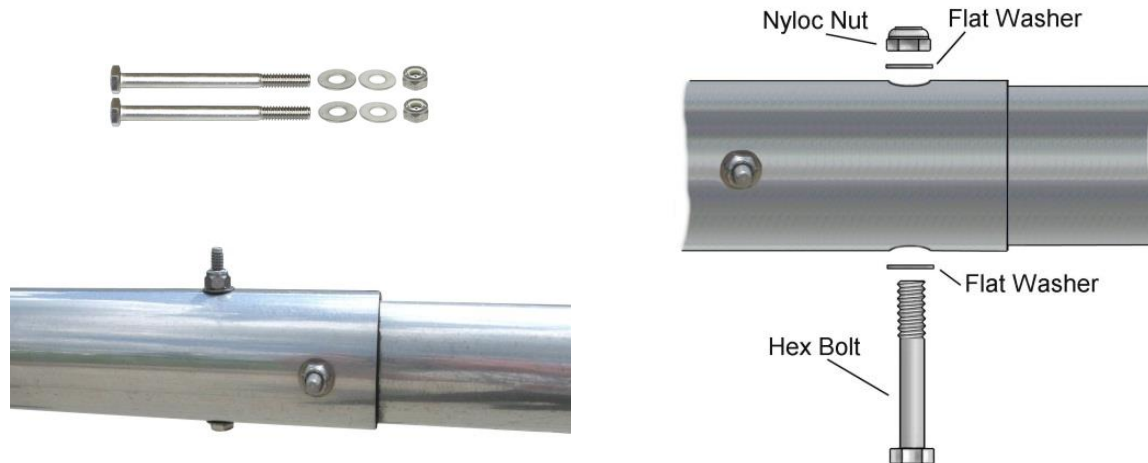

DANGER: When raising or lowering the vertical antenna make sure you have not inadvertently located the antenna underneath or near power lines. Residential power lines are often less than 40' high. Contact with any power or utility lines Can Be Lethal !

In areas where there is a high atmospheric static condition (areas prone to precipitation or snow static) this antenna (as with all antennas) will build up a static charge. When working on the antenna, especially in the raised position, you may want to ground the antenna to bleed off any static before touching the antenna. (Obviously, you also do not want RF present on the antenna when touching it). When installed, the base series and shut coils (described below) will also act as a constant static bleed for your vertical antenna in areas where precipitation static or snow static is present.

When the vertical elements are all connected together, the overall total length measured from the bottom of the 3" OD base element to the top of the capacity hat assembly will be approximately 55 feet in length.



Base Series and Shunt Coil Assembly and Installation

Two coils are used at the base of the antenna. One coil is in series with the antenna feed point; the other coil is shunt coil and is connected to the Radial Plate. Attach the series coil with the straight bracket on the antenna feedpoint using the hardware as shown.

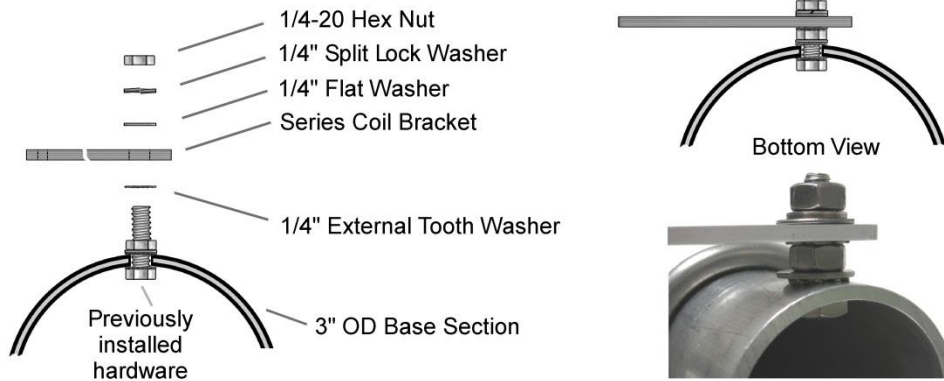

Install the shunt coil with the “L” bracket to the radial plate on top of an existing radial wire bolt using the hardware as shown below. The wire (with terminals) is connected from one end of the series coil to the shunt coil (top connection). At this same connection point the wire with the PL-259 on the other end, is connected to this same point.

Position the shunt coil on the Radial Plate to allow the wire to connect to the series coil and not interfere when pivoting the antenna.

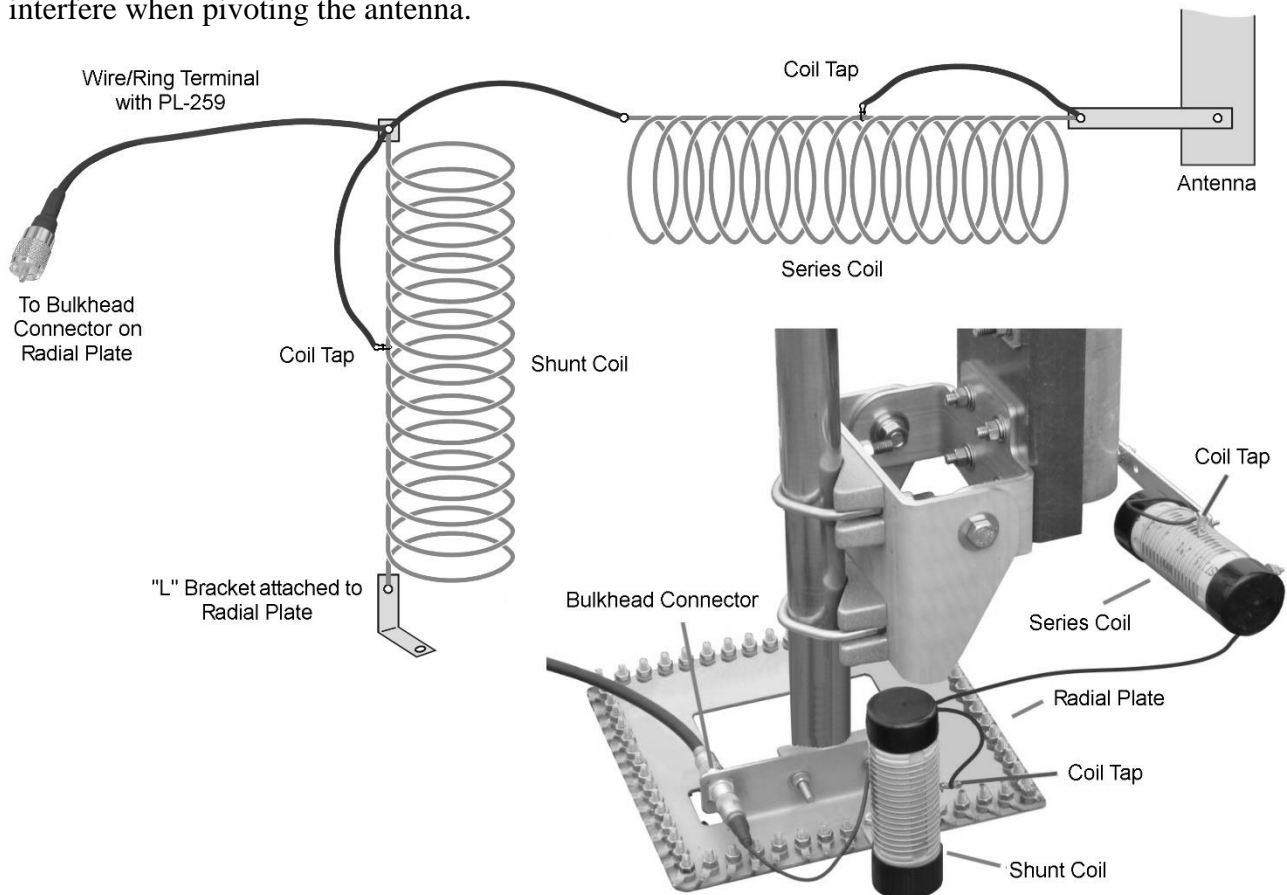

**Series Coil Mounting Hardware
Installed and shown for reference**

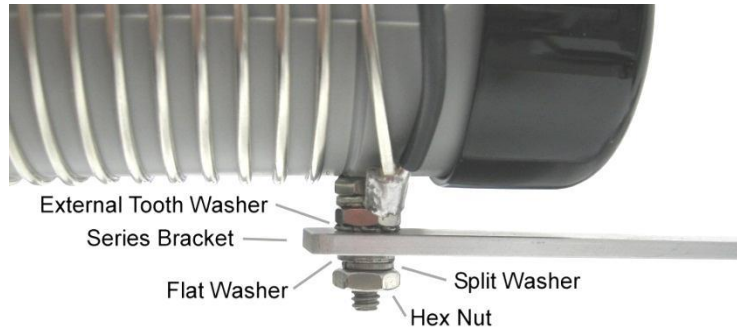

**Shunt Coil and Mounting Hardware
For mounting to the optional Radial Plate**

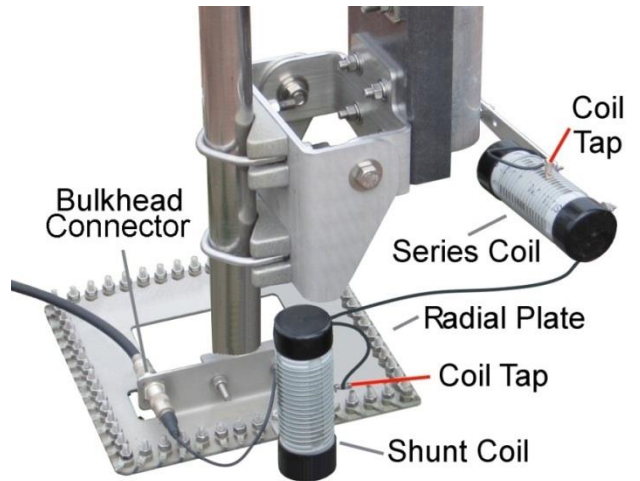
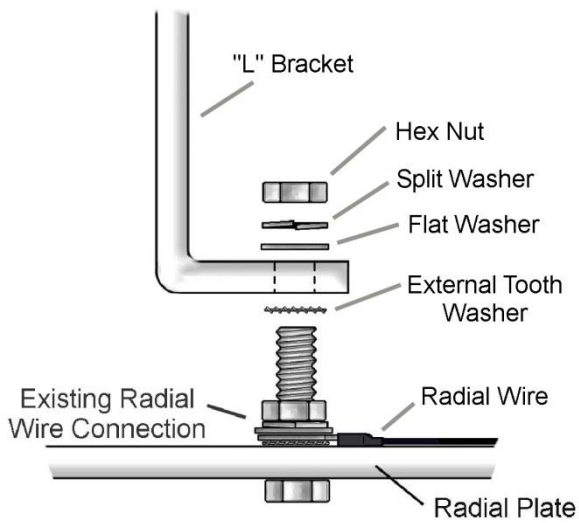

Mounting the optional SecureMount™ Bulkhead Connector to the optional Radial Plate

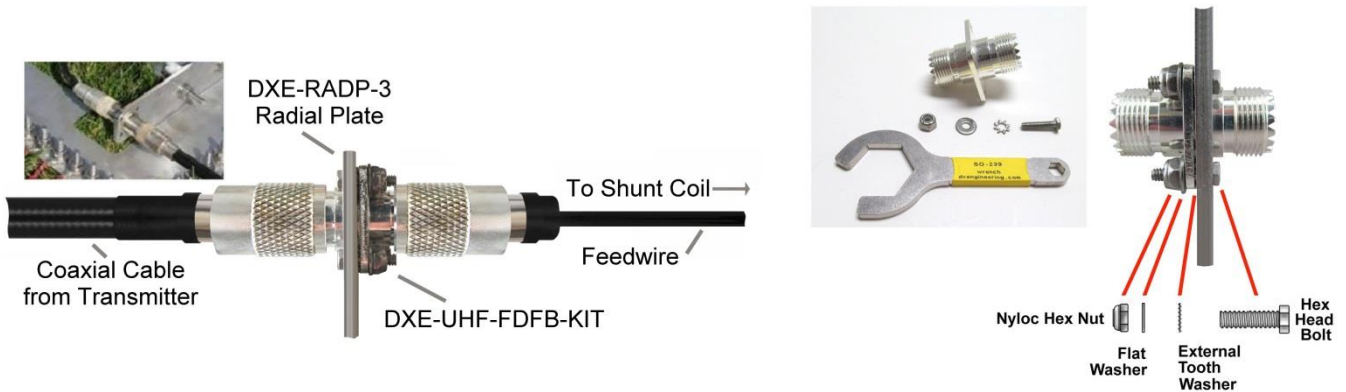

Capacity Hat Information

The capacity hat is made up of special mounting hardware at the top of the antenna. The capacity hat uses four 39 foot 14 gauge wires coming from the top of the antenna in a four sided pyramid shape connected to four 24 foot 14 gauge wires at the base of the pyramid. The bottom joints of the capacity hat (the pyramid) will then be guyed using the included rope to the guy points that are 55 feet from the antenna base.

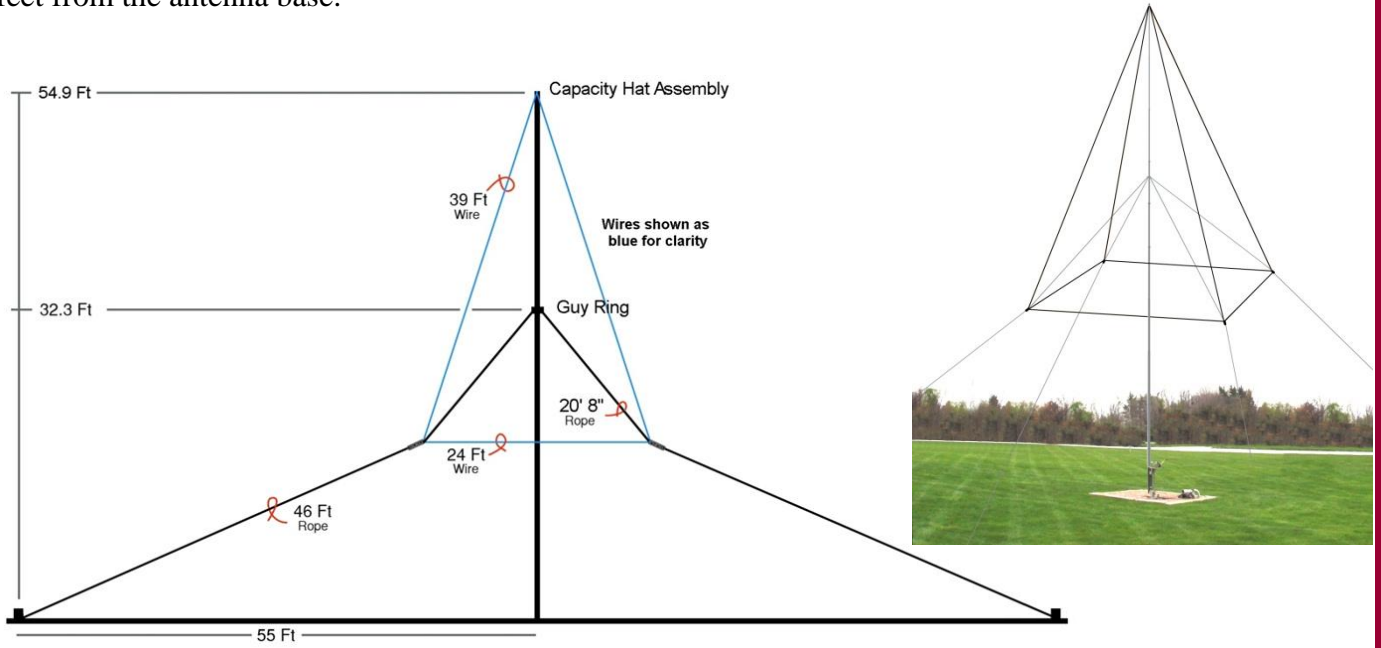

Side View (Capacity Hat wires shown in Blue for clarity)

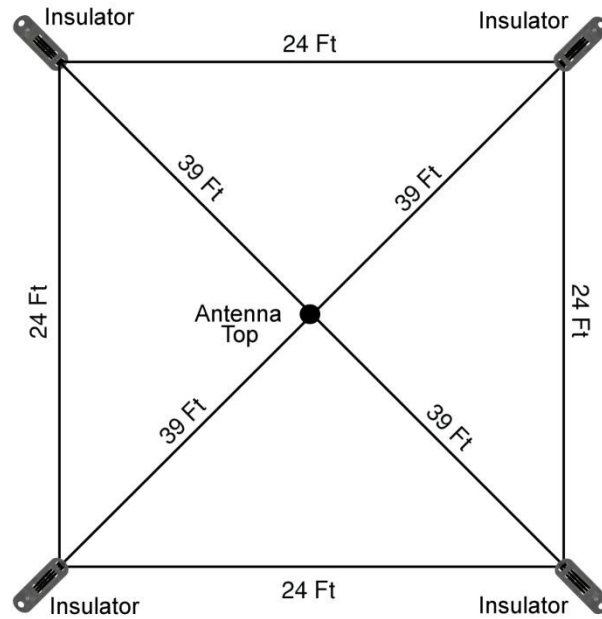

Capacity Hat Wires and Insulators - Top View

Capacity Hat Assembly

1. Locate the eight wires for the capacity hat. Four wires are 39 feet in length. Four wires are 24 feet in length. Ring Terminals are installed on the ends of the wires.

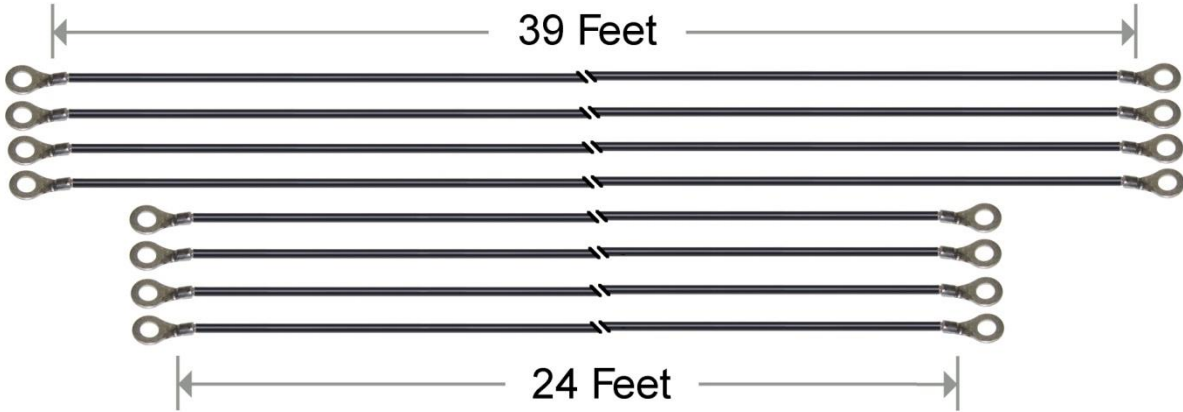

2. Gather the other parts required for the Capacity Hat assembly.

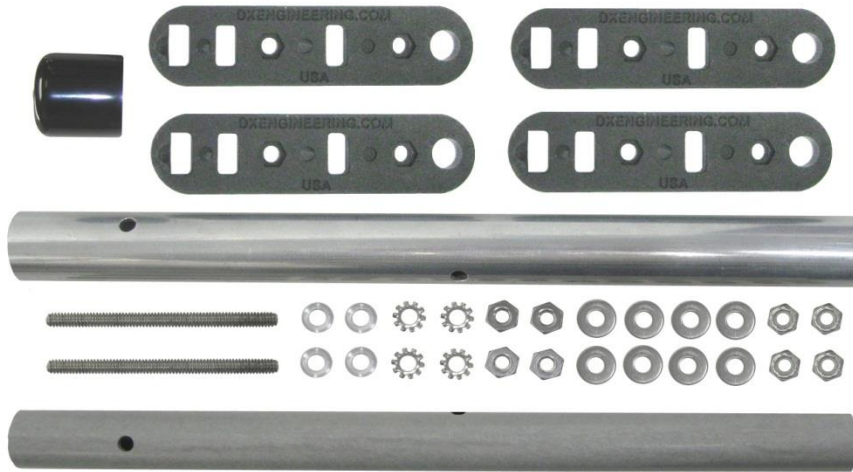

3. If not already done, insert the fiberglass tube into the aluminum tube making sure the drilled holes are aligned.

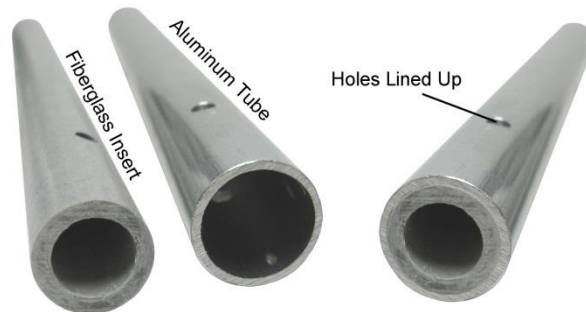

Notes on the capacity hat assembly:

- Two threaded rods are installed (centered) in the drilled holes.
- Each side of the threaded rod will get one of the 39 foot wires with ring terminal and be held in place using an external tooth washer and a stainless steel hex nut as shown.
- Aluminum spacers are pressed into the patented insulators as shown.
- Note the positioning of the patented insulators (**look carefully for cupped area**).
- Prior to installing the four patented insulators on the two threaded rods, one end of the 39 foot wires will be routed through the patented insulators.

The following pictures detail the assembly of the capacity hat assembly

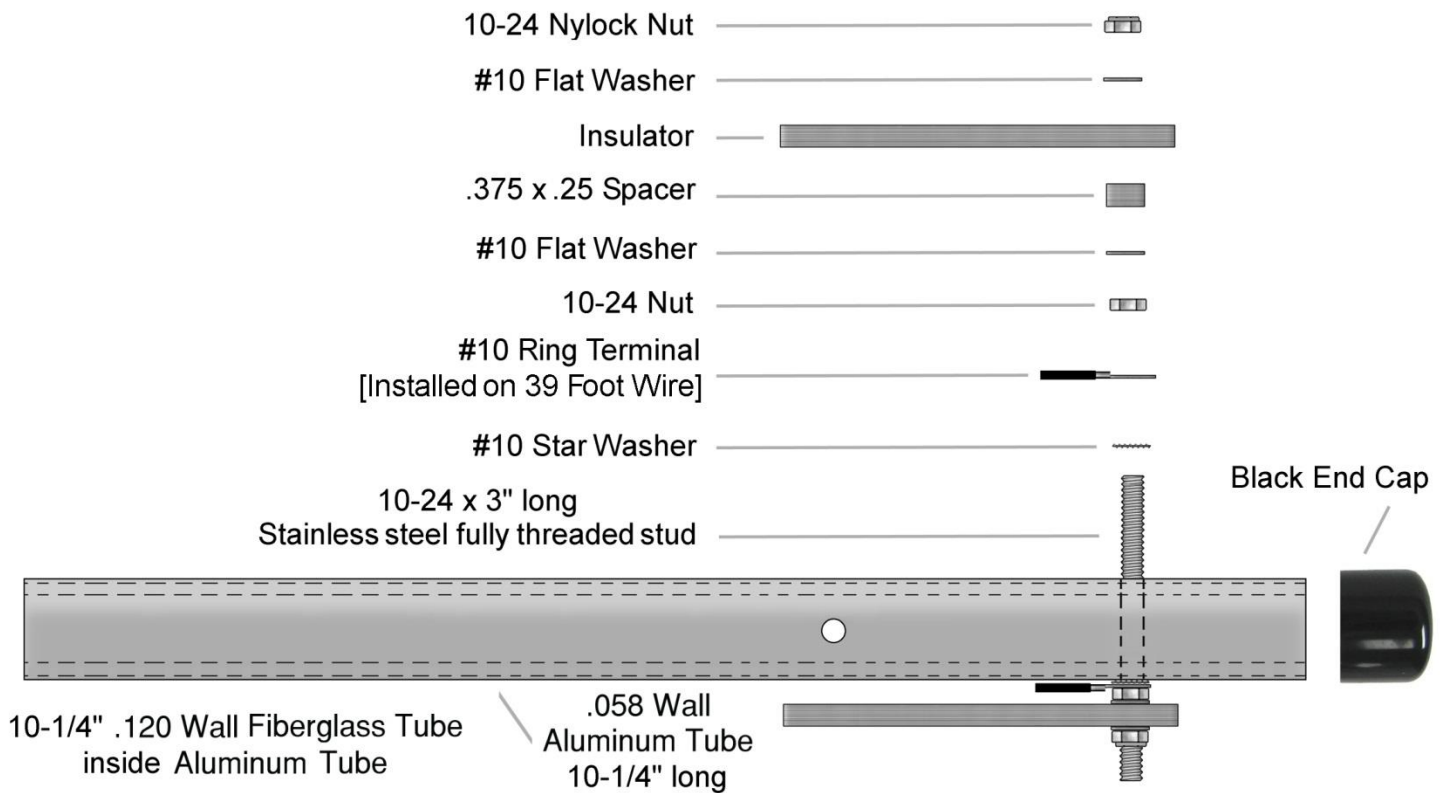

Exploded view

Cupped Area on Insulator



Note the cupped area



Insert the aluminum spacers

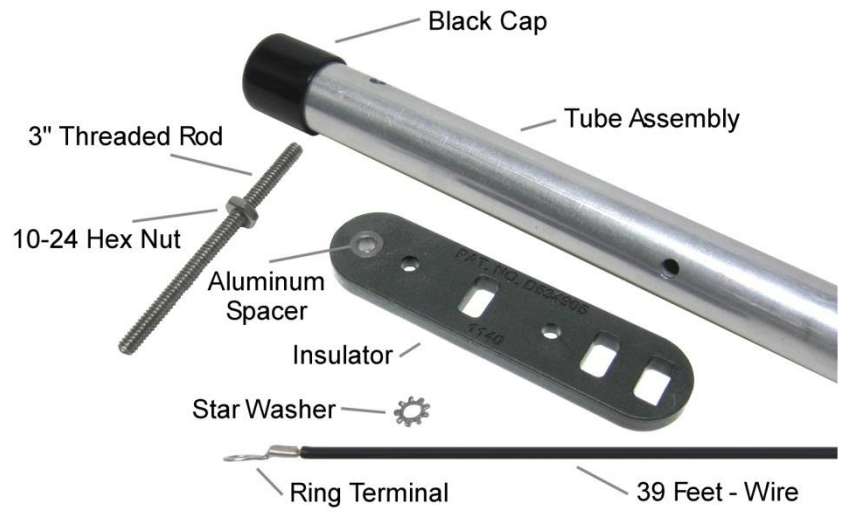

Note the routing of the 39 foot wire/ring terminal end through the insulator



Once the ring terminals are in place, tighten the hex nuts evenly on both sides. **Note the way the ring terminals are placed and direction of the wires.**

Install a flat washer, insulator, flat washer and Nyloc hex nut on the threaded rod and tighten in place. The stack up of the hardware will allow the insulator to move slightly. Also seat the wires in place in the insulators as shown below.



Four views showing the capacity hat assembly with the upper two insulators and wire/ring terminals installed.

Repeat the assembly steps to install the lower two insulator/wire assemblies.



Completed Capacity Hat Assembly - *Note how the wires are routed*

Installing the Capacity Hat on the Antenna

1. Mark the bottom of the Capacity Hat Assembly 3-1/4" from the bottom end.
2. Slide a **DXE-ECL-1000** element clamp over the 1" OD element tube at the top of the antenna. Slide the completed capacity hat assembly into the 1" OD element tube to the 3-1/4" mark. Tighten the **DXE-ECL-1000** clamp in place. Do not over-tighten which may cause clamp damage. Alignment of the Capacity Hat Assembly in regards to the overall antenna assembly is discussed later in the manual in the Guying section.



Capacity Hat Bottom Wires

1. The four 39 foot wires coming from the Capacity Hat Assembly at the top of the antenna are joined with the horizontal 24 foot wires using four insulators and associated hardware.
2. Install the capacity hat wires as shown in the following diagrams and photographs.

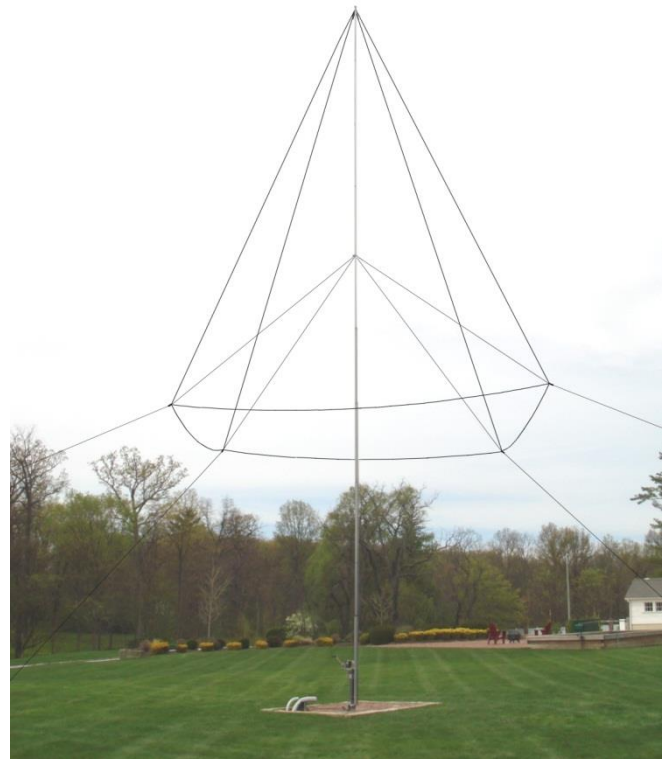
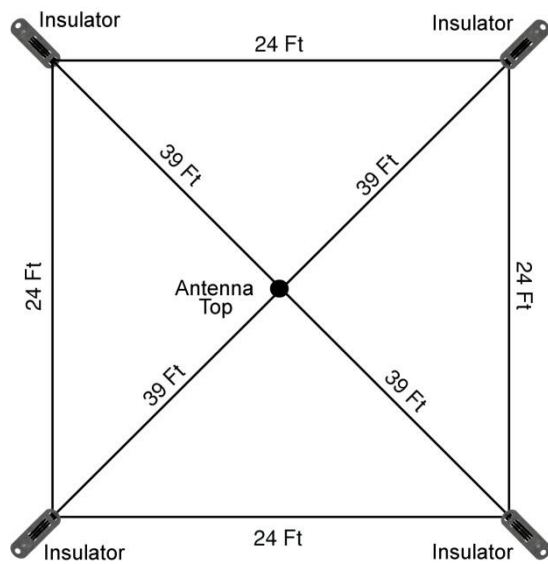
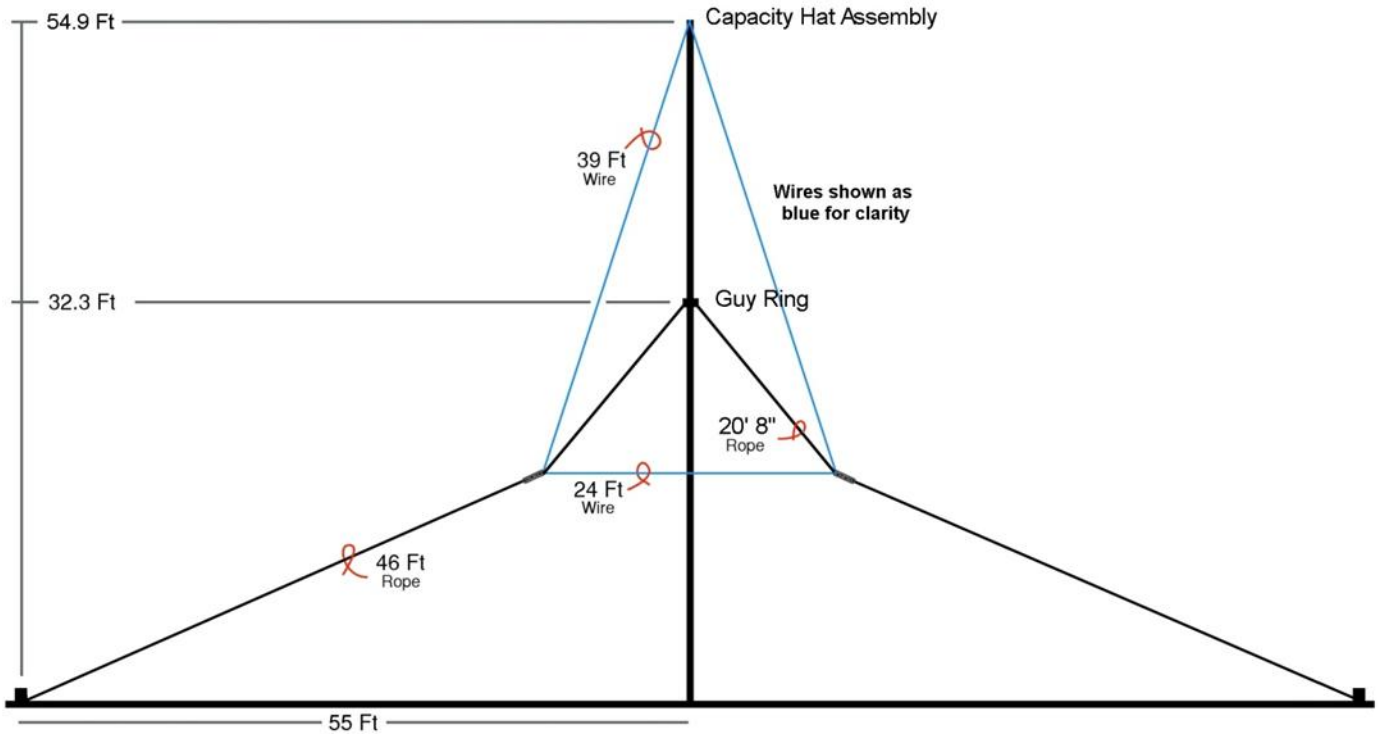

- Using the four patented insulators, 10-24 x 3/4" hex bolts, #10 external star washers, #10 flat washers and the 10-24 Nyloc hex nuts, join the 39 foot wires coming from the capacity hat assembly with the 24 foot wires together as shown below.

Note how the three wires are woven through the insulator in the following photographs.

Refer to the overhead picture on the previous page for an overall picture of how the capacity hat should look when assembled.

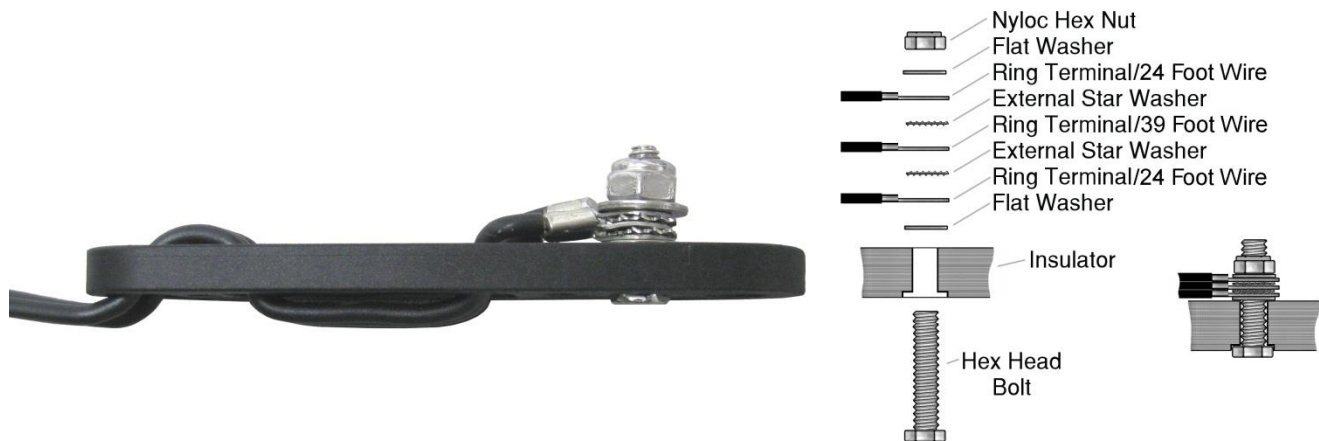

Top View



Bottom View



No-Slip Knots

No-slip knots are the most efficient way to securely tie ropes for antennas. The following diagram shows the steps to make a good no-slip knot.

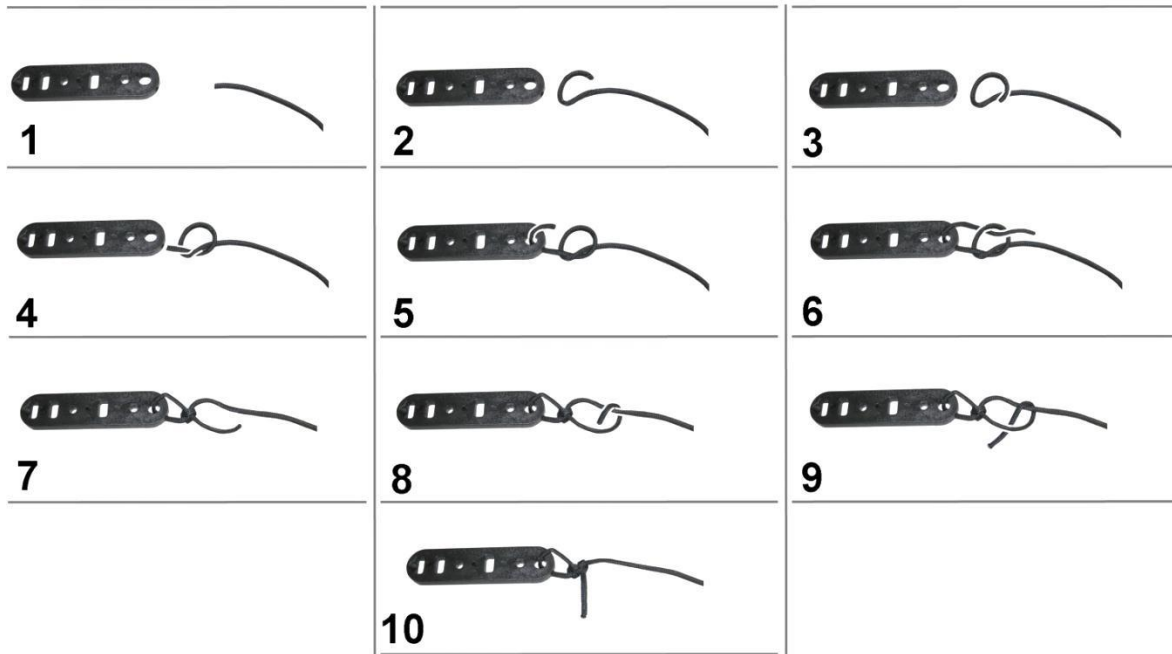

Guy Rope Installation

Guy ropes are made from the 100 foot spools of rope included with this antenna. Two sets of four ropes are installed. One set of four 20' 8" ropes are connected to the antenna at the guy ring using carabineers and connected at the other end at the lower insulators (connecting the capacity hat wires together). The other set of four 46' guy ropes are connected to the lower four insulators (connecting the capacity hat wires together) and go to the four optional earth anchors.

It is suggested that these ropes be anchored in the ground 55 feet away from the base of the antenna using the optional **DXE-EA15-4P** Earth Anchors available from DX Engineering. Your soil conditions may require different guying scheme. The DX Engineering anchors may not be suitable for real loose sandy soil or rock.

Cut four ropes at 48 feet each, and four ropes at 23 feet each. This allows about 1-1/2 feet on each end for looping and tying knots.

Using the four Carabineers, tie one end of the four 23 foot ropes using a no slip knot.



The four Carabineers are then attached to the Guy Ring. The Carabineers open when pushed.

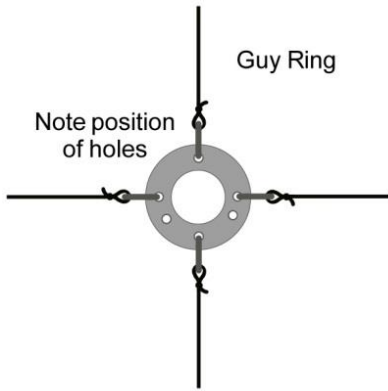

Guy Ring

Note the four holes used on the guy ring.



Guy Ring mounted on antenna



Carabineer open

Four 46 foot ropes are attached to the four insulators used for the bottom of the capacity hat. The four 23 foot ropes are also attached to the four insulators and when tied should be 20' 8" long.

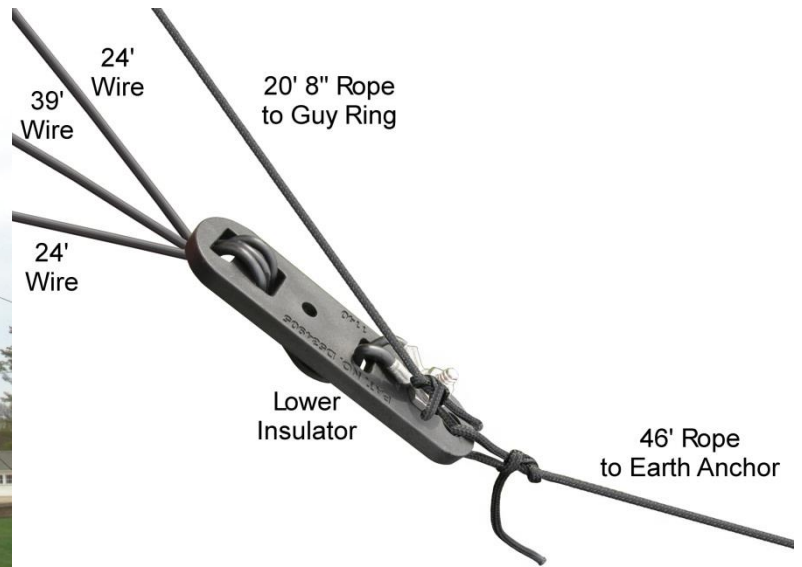

Adjustments should be made to align the guy ropes in the manner that allows you to raise and lower the antenna by only removing one set of guys from the earth anchors. **DXE-EA15-4P** Earth Anchors work very well for most installations and are available from DX Engineering. Tie the loose ends of the four 46 foot ropes at four points 55 feet from the antenna. See the diagram on the next page for details. The ropes should be snug, but not overly tight. The four ropes going from the earth anchors to the capacity hat keep the wires properly spaced from the vertical antenna and the four ropes going to the guy ring give the antenna stability. By adjusting the position of the Capacity Hat and Guy Ring to have the ropes as shown below, only one set of guys needs to be loosened from one earth anchor when pivoting the antenna.

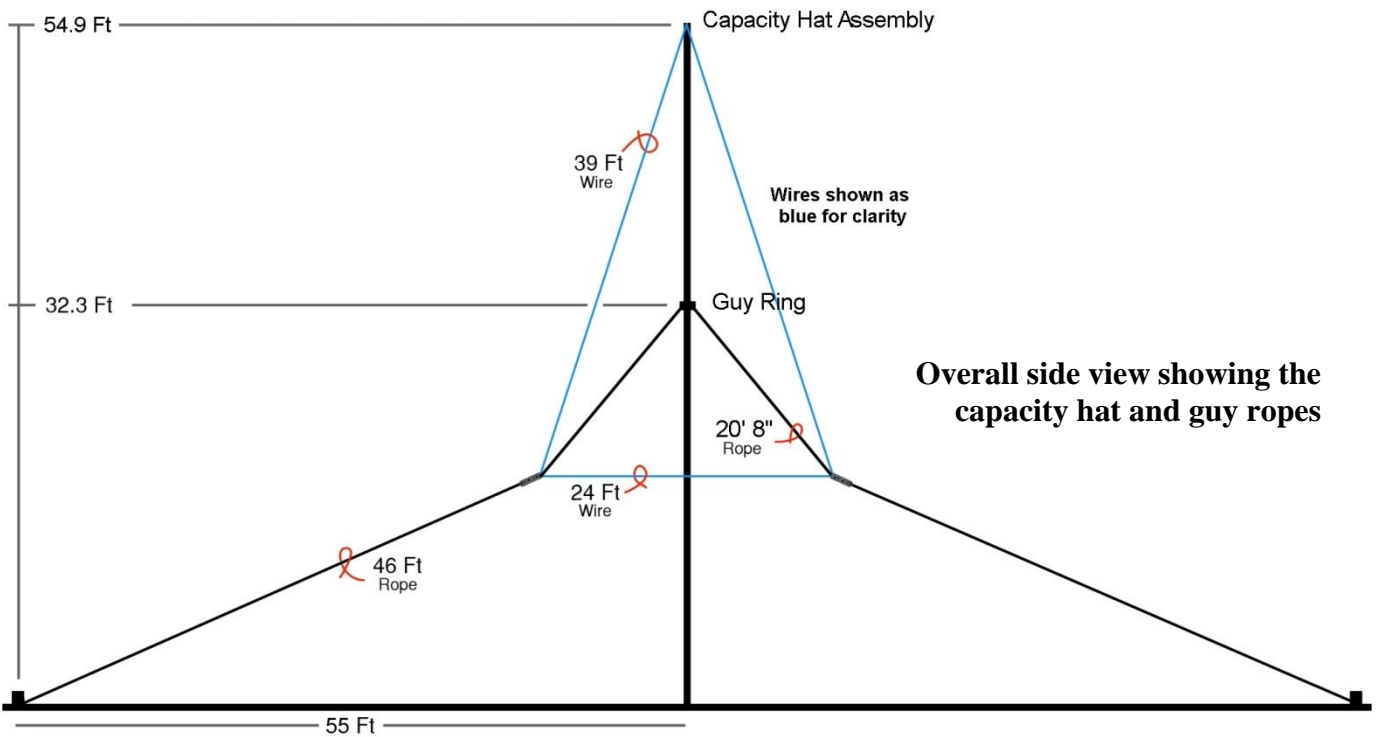
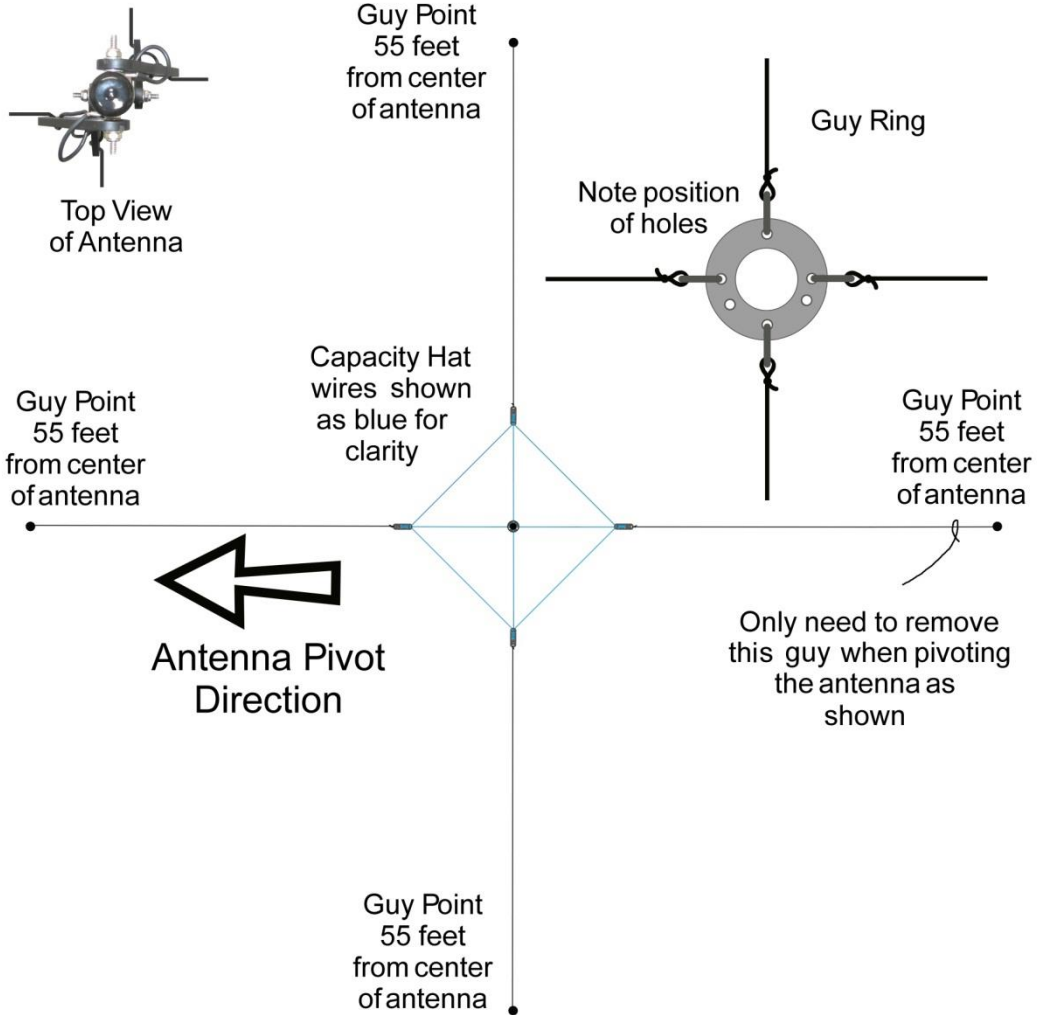

Tuning

Tuning Hints

According to prior instructions, assemble and erect antenna, radial plate, radials and top hat and then the two tuning coils (series and shunt) to the base of antenna and radial plate. Raise the antenna.

Staying at least fifty feet from the base of the antenna (using at least a 50' piece of low loss coax such as RG-213U) set up to use either an antenna analyzer or an HF radio as an SWR indicator. A fifty foot RG-213U with PL-259 connectors installed is available from DX Engineering.

In some areas, due to the signal capture ability of this antenna at low frequencies and the close proximity of AM Broadcast Stations some Antenna Analyzers may not be able to be used. It will be necessary to use a normal HF rig with an SWR indicator. We have used both methods and the results are the same.

To determine if your location is near AM broadcast stations which may interfere, go to this website and enter your location: Using your zip code: <http://radio-locator.com/>

Using Longitude and Latitude information - <http://radio-locator.com/cgi-bin/locate?select=lonlat>
Naturally, using your Longitude and Latitude information [which can be obtained on your qrz.com page] is MUCH more accurate.

Tuning Procedure

Place the SWR coil tap clip-lead in the middle of the **Shunt Coil** (the coil mounted to the Radial Plate on the "L" bracket).

Short out the **Series Coil** (the coil mounted to the antenna feedpoint with the straight bracket) completely with the coil tap clip-lead provided.

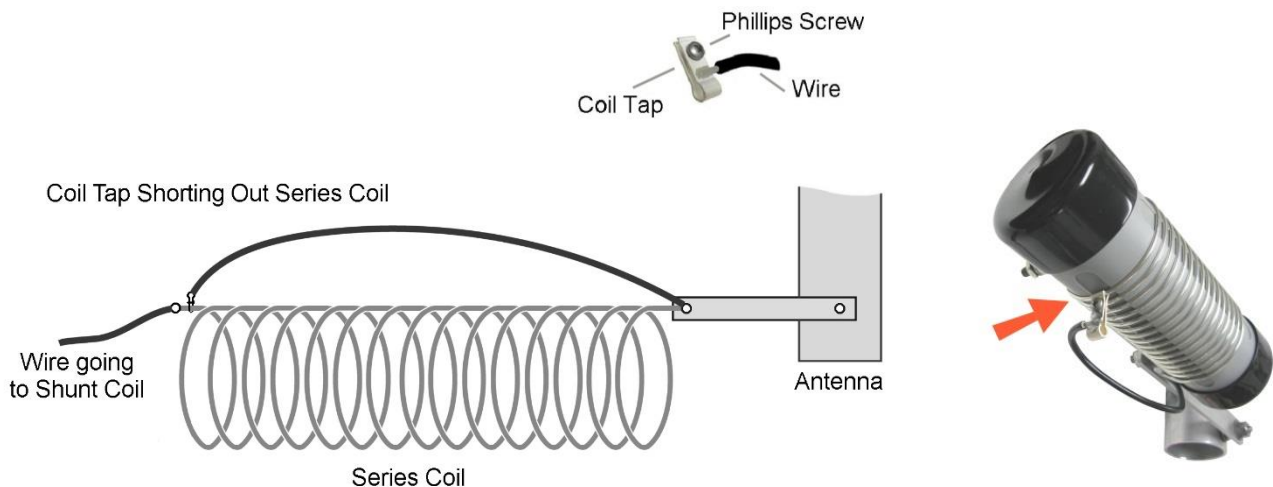

Look for the lowest SWR on the Radio or Analyzer. A typical reading would be: Approximately 1.4:1 SWR at approximately 1.885 MHz. If you don't see an SWR dip look higher or lower in frequency and adjust the top hat and length of the vertical to get the SWR dip approximately as shown in the SWR graph.

Move the shorting lead on the **Series Coil** to about the middle turn. A typical reading would now be approximately 1.5:1 SWR at approximately 1.800 MHz

To raise the Resonant Frequency, adjust the **Series Coil** shorting lead to short out more of the coil.

To lower the Resonant Frequency, adjust the **Series Coil** shorting lead to short out less of the coil.

Adjust the **Shunt Coil** to achieve the lowest SWR. This may cause the Resonant Frequency to change slightly since the 2 coils interact somewhat.

Readjust the **Series Coil** to arrive at the frequency where you wish to have the lowest SWR.

A typical final reading will be approximately 1.2:1 SWR at 1.824 MHz.

Once final tuning is complete and you have verified correct operation on-the-air, the coil taps can be soldered in place to eliminate any future intermittent connections due to environmental corrosion to the coil taps and coil wire connections.

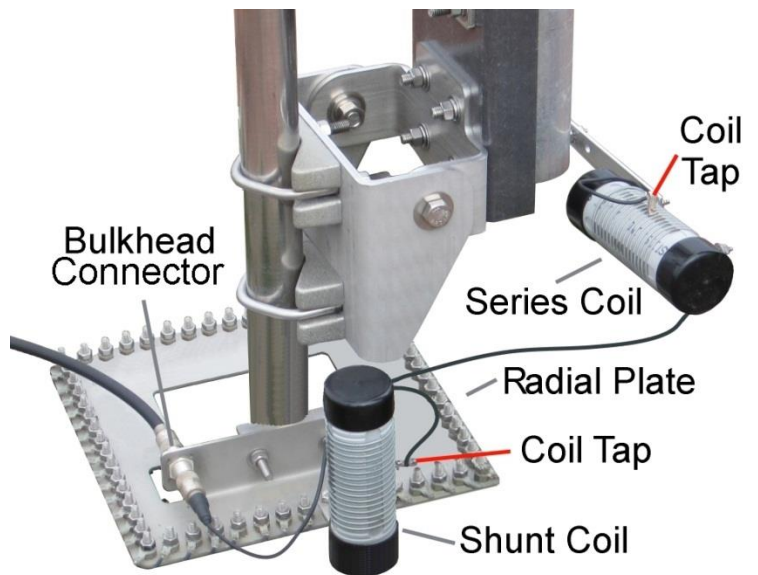

Typical SWR Graph

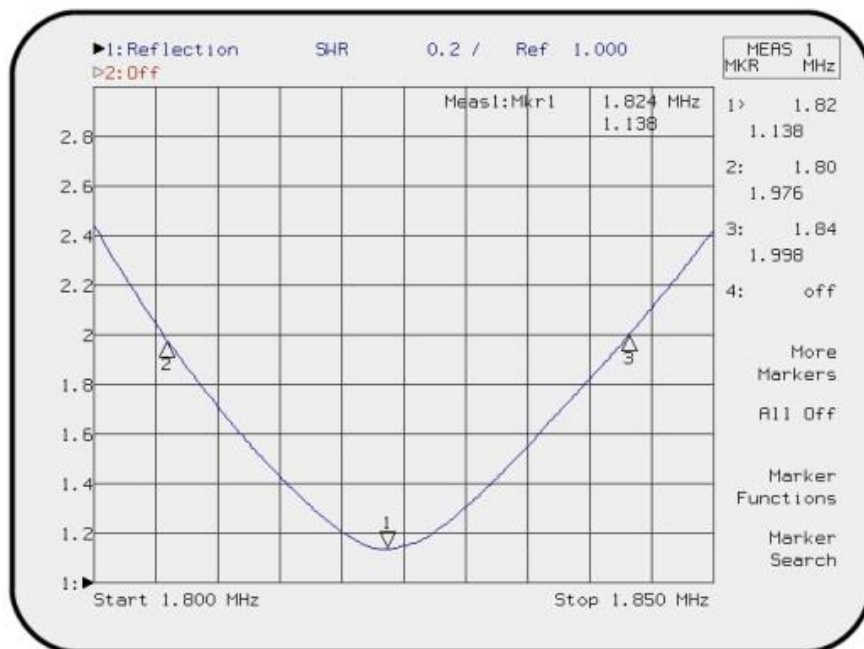

The antenna exhibits more than a 40 kHz wide 2:1 SWR Bandwidth as shown in the graph above which is a screen shot from a calibrated **Agilent 8714ET** Network Analyzer.

Using an Icom IC-718 Radio with an internal tuner DX Engineering Design and Test Engineers were able to reduce the SWR at the 2:1 points down to 1:1 easily. This will extend the use of the antenna significantly beyond the 2:1 points shown above. Almost any radio with a built in tuner - and certainly with an external tuner of any reasonable ability - will be able to do the same.

The adjustment of the Series Coil and the top-hat will allow wide excursions inside and slightly above and below the 160 meter band, if desired. DX Engineering will not be able to supply detailed instructions for this but basic antenna principles will apply: A larger top-hat or use of more of the Series Coil will lower the frequency whereas a smaller top-hat or using less of the Series Coil will raise the frequency. The adjustment of the Shunt Coil will reduce the SWR.

Locking the Pivot Base

To help prevent accidental pivoting, ensure the four pivot locking bolts are in place and properly secured. Additionally, you may replace one of the bolts with a padlock to further prevent tampering or accidental pivoting as shown below.

Ensure all four Pivot Locking Bolts are in place

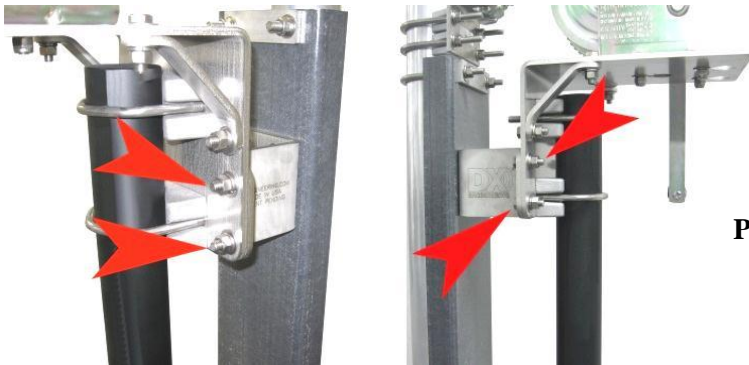

Padlock used in place of one Pivot Locking Bolt

DXE-160VA-1 Parts Lists

Detailed patented Pivot Base Drawing with numbered parts

- 1 Base Side Bottom Hinge
- 2 Antenna Side Bottom Hinge
- 3 Bottom Hinge Bushing
- 4 Extren® Insulated Channel
- 5 Saddle Backing Plate 1/4" Thick
- 6 Antenna Hook Mount
- 7 Pivot Base Winch Mount
- 8 Pivot Base Plate Bracket
- 9 Pivot Base Lock Plate
- 10 Backing Plate, Square
- 11 Saddle Spacer Plate 3/8" Thick
- 12 3" U-Bolt
- 13 3" Cast Saddle
- 14 3/8" Flat Washer
- 15 3/8" Split Washer
- 16 3/8-16 Hex Nut
- 17 3/8-16 x 1.25 Hex Bolt
- 18 3" Cast V-Saddle
- 19 3/8-16 V-Bolt
- 20 3/8-16 x 1-1/2" Carriage Bolt
- 21 1/2-13 x 1-1/4" Hex Bolt
- 22 1/2" x 1-1/4" Washer
- 23 1/2" Lock Washer
- 24 1/2-13 Hex Nut
- 25 3" x 72" Antenna Base Element
- 30 Customer Supplied Mounting Pipe

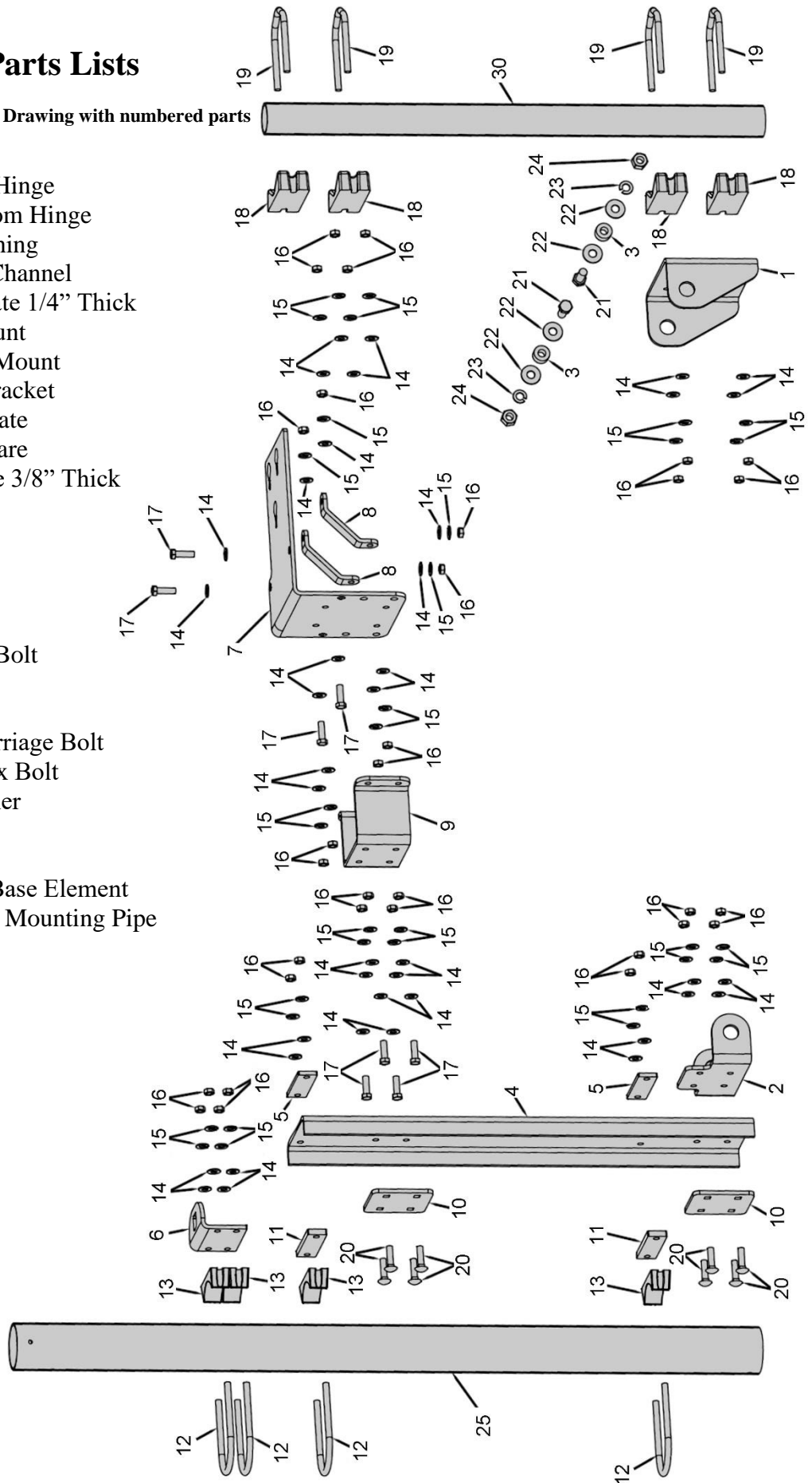

DXE-160VA-1 Parts Lists

Pivot Base Assembly - US Patent No. 8,130,168	
QTY	Description
1	Base Side Bottom Hinge
1	Antenna Side Bottom Hinge
2	Bottom Hinge Bushing
1	Heavy Duty Extren® Antenna Insulator Channel
2	Saddle Backing Plate, 1/4"
1	Antenna Pivot Hook Mount
1	Pivot Base Winch Mount
2	Pivot Base Plate Bracket
1	Pivot Base Lock Plate
2	Backing Plate, Square
2	Saddle Spacer Plate, 3/8"
4	3" Stainless U-Bolt
4	3" Cast Saddle Clamp
40	3/8" Flat Washer
32	3/8" Split Lock Washer
32	3/8-16 Nut
8	3/8-16 x 1.25" Long, Hex Head Cap Screw
4	Cast V-Saddle
4	3/8-16 V-Bolt
8	3/8-16 x 1-1/2" Long Stainless Steel Carriage Bolt
2	1/2-13 x 1-1/4" Long Stainless Steel Hex Head Cap Screw
4	1/2" x 1-1/4" Stainless Steel Washer
2	1/2" Stainless Steel Lock Washer
2	1/2-13 Stainless Steel Nut

Feedpoint Hardware	
QTY	Description
1	14/-20 x 1-1.25" long Stainless Steel Hex Bolt
1	1/4" Stainless Steel Split Lock Washer
2	1/4" Stainless Steel Flat Washer
3	1/4" External Tooth Stainless Steel Washer
2	1/4-20 Stainless Steel Hex Nut
1	Coil Mounting Bracket, Aluminum, 2 Drilled Holes

Series and Shunt Coil Assemblies	
QTY	Description
1	Series and Shunt Coils with connection wires attached.
1	Mounting hardware



Vertical Elements Assembly	
QTY	Description
1	3" OD x 72" long, .120" wall, 5 drilled holes
1	2.75" OD x 48" long, .120" wall, 8 drilled holes
1	2.5" OD x 72" long, .120" wall, 8 drilled holes
1	2.25" OD x 72" long, .120" wall, 8 drilled holes
1	2" OD x 72" long, .120" wall, 4 drilled holes, slits one end
1	1.75" OD x 72" long, .120" wall, slits on one end
1	1.5" OD x 72" long, .120" wall, slits on both ends
1	1.25" OD x 72" long, .058" wall, slits on one end
1	1.125" OD x 72" long, .058" wall, slits on one end
1	1" OD x 72" long, .058" wall, slits on one end
1	DXE-ECL-1000 Stainless Steel Element Clamp
3	DXE-ECL-1250 Stainless Steel Element Clamp
3	DXE-ECL-1500 Stainless Steel Element Clamp
3	DXE-ECL-1750 Stainless Steel Element Clamp
2	DXE-ECL-2000 Stainless Steel Element Clamp
2	1/4-20 x 2-34" long Stainless Steel Hex Head Bolt
2	1/4-20 x 3" long Stainless Steel Hex Head Bolt
2	1/4-20 x 3-1/4" long Stainless Steel Hex Head Bolt
2	1/4-20 x 3-1/2" long Stainless Steel Hex Head Bolt
16	1/4" Stainless Steel Flat Washer
8	1/4-20 Stainless Steel Nyloc Hex Nut

Capacity Hat Assembly	
QTY	Description
1	Aluminum Tube/Fiberglass Tube assembly, Drilled
4	Aluminum Spacer, 0.375" x 0.25" x #10
8	Insulator (US Patent No. D534,905)
2	18-8 Stainless Steel Fully Threaded Stud 10-24 x 3"
4	# 10-24 x 3/4" Stainless Steel Hex Bolt
12	# 10 Stainless Steel Star Washer
16	# 10 Stainless Steel Flat Washer
4	# 10-24 Stainless Steel Nut
8	# 10-24 Stainless Steel Nyloc Hex Nut
16	# 10 Stud, 10-12 AWG Ring Terminal
4	14 ga Black Wire, 39 feet with Ring Terminal attached
4	14 ga Black Wire, 24 feet with Ring Terminal attached
3	100 ft - 3/32" Double-Braded Dacron/Polyester Rope
1	Vinyl End Cap, Black
1	1.510" ID Aluminum Guying Plate
4	Carabineers, Stainless Steel

Optional DXE-VRW-1 Manual Winch Assembly	
QTY	Description
1	1500 Pound Exposed Gear Hand Winch with Brake
1	Custom Polyester web strap with Hook, 2" x 15 Ft
1	3/8-16 x 3-1/2" long Grade 8 Hex Head Bolt
4	3/8-16 Stainless Steel Nyloc Nut
3	3/8-16 x 1" long Stainless Steel Hex Bolt
8	3/8-16 Stainless Steel Flat Washer

Note: This antenna system is shipped in several boxes. The hardware parts maybe in more than one box.

Additional Material Required, Not Supplied:

DXE-VGMT-3CG -Antenna Mounting Pipe - 3" OD x 7 Feet long 1/4" Wall thickness - Galvanized Chromoly Steel mounting pipe.

Concrete - For mounting pipe installation (*see text for suggestions*)

Suggested Parts Not Included

DXE-VRW-1 - Manual Winch Add-on Raising Kit

Manual winch add-on kit for the High Performance DX Engineering vertical antennas. The tilt fixtures for these antennas are equipped to accept the winch directly. Allows easy raising and lowering of tall antennas - may be easily moved from one antenna to another in multi-antenna arrays.

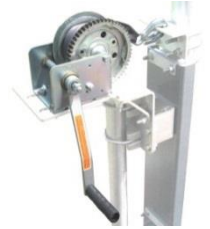

DXE-RADP-3 - Radial Plate (*US Patent Nos. 6,927,740 and D533,167*):

Made from Laser Cut Stainless Steel with 20 Sets of Stainless Steel Radial Attachment Hardware. The DX Engineering Radial Plate is meant for those of you having a vertical antenna and want an easy, neat and effective way to connect those essential radial wires to your antenna system for the highest efficiency and strongest signals.



DXE-SSVC-3P - Stainless Steel V-Clamp for 2 to 3 inch steel pipe

This V-Clamp is made in one size that fits Steel tubing or pipe from 2 to 3" OD as used in antenna construction. The supplied V-bolt is long enough to attach tubing to thick plates and is made with anti-corrosive properties. The special Stainless Steel saddle has serrated teeth will clamp to the pipe securely by biting into the surface. For this reason, it is not recommended for softer aluminum tubing or pipe. U-Bolt thread dimensions: 3/8"-16 x 1.75". V-bolt and saddle made from high-strength 18-8 stainless steel



DXE-RADP-1HWK - Radial Plate Wire Attachment Hardware Kit - Stainless Steel

Additional 20 Sets of ALL Stainless Steel Radial Hardware for use with the DX Engineering Stainless Steel Radial Plate.

(20) 1/4" Bolts - (20) 1/4" Nuts - (20) 1/4" Flat Washers

(20) 1/4" Split Washers - (20) 1/4" Star Washers

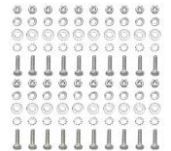

DXE-UHF-FDFB-KIT - Silver Plated Female SecureMount™ Bulkhead Connector - Dual SO-239

The DX Engineering Silver Plated Female SecureMount™ Bulkhead Connector is a high-quality silver-plated connector that provides a positive, permanently secure connection for your coaxial cable. The two-sided SO-239 female connector has a superior silver-plated body with silver contacts to ensure the best performance for any application. The SecureMount™ flange, which employs four mounting screws, means that the bulkhead connector won't work loose like those with concentric nuts and washers. Once mounted to any panel or bulkhead, the flanged bulkhead connector will provide the best possible connection and stay that way. Additionally, when using our Radial Plate, Tower Leg Brackets or SO-239 Mounting Brackets, the SecureMount™ Bulkhead Connectors are the best way to bond your coax to ground this side of Cad-Welding! Unlike many common nickel-plated bulkhead connectors, our silver-plated SecureMount bulkhead connectors have no air space within their midpoint. This area of solid and superior PTFE dielectric between the center conductor and body maintains constant impedance and ultimate performance.

- Description: Bulkhead mount, UHF jack to UHF jack (SO-239)
- Body Material: Brass
- Body Plating: Silver
- Body Style: Flanged Dual Female SO-239
- Contact Plating: Silver
- Frequency Range: DC - 500 MHz
- Dielectric: PTFE
- Impedance: 50 ohms

Includes Stainless Steel Hardware Kit for mounting



DXE-EA15-4P - Earth Anchor, Package of 4

Utilize these earth anchors with STI Double-braided Polyester ropes to build a custom guying system for your vertical antenna. 15" long x 3" diameter.



JTL-12555 Jet-Lube™ SS-30 Pure Copper Anti-Seize

Jet-Lube™ SS-30 Pure Copper Anti-Seize is the top choice of engineers and technicians in government, industry and leading Amateur Radio contest stations, for protecting mechanical assemblies of aluminum tubing, general hardware and copper grounding systems. On bonded metal surfaces Jet-Lube™ SS-30 assures electrical and RF conductivity while preventing oxidation and corrosion. Surpassing the capabilities of other aluminum anti-oxidants, the wide temperature range of Jet-Lube™ SS-30 prevents long-term drying and caking, and allows easy disassembly and effortless cleaning of parts. An environmentally preferred thread lubricant and conductive termination compound, Jet-Lube™ SS-30 helps keep your equipment in serviceable condition. It contains a high concentration of copper flakes, a requirement for heavy loads or compression; controlled frictional characteristics allow the surfaces of nuts and bolts to be tightened to their design torque specifications. This anti-seize product assures full hydraulic efficiency by allowing the metal surfaces to slide over each other without damaging metal-to-metal contact. Jet-Lube™ SS-30 is also designed to work as a similar and dissimilar component between two metal surfaces to prevent seizing and galvanic action. The SS-30 compound formula improves conductivity and ground continuity - and will not melt in high temperatures.



Jet-Lube™ SS-30 Pure Copper Anti-Seize Features include:

- * Meets MIL-PRF-907E spec
- * K-factor: 0.13
- * Service rating: -65 degrees F (-54 degrees C) to 1800 degrees F (820 degrees C)
- * SS-30 Resistivity (ohm-CM x 108) 5

*** This product is limited to domestic UPS Ground shipping only**

Optional Accessory Items

DXE-T001 - DX Engineering SO-239 Connector Installation Tool Kit

This DX Engineering SO-239 connector installation tool kit offers an easier installation of chassis or bulkhead mount SO-239 coaxial connectors. Having the right tools can make all of the difference in your shack, and this handy DXE tool provides you with a special dual-use stainless steel wrench, plus a multipurpose 6-in-1 screwdriver/nut driver tool. One end of the wrench is a 3/4 in. semi-box wrench with a pass-through for coaxial cable-- perfect for tightening the larger nuts used to mount bulkhead connectors. The other end is a 3/16 in. box wrench for tightening mounting nuts with SO-239 hardware. You'll receive six combinations - two Phillips heads, two flatheads, and a 1/4 in. nut driver and a 5/16 in. nut driver, which store in the handle of the screwdriver. The added SO-239 wrench is ideal for use with the **DXE-UHF-FDFB-KIT** - Silver Plated Female SecureMount™ Bulkhead Connector.



DXE-RADW - 500K or 1000K Radial Wire Kits and Components

To achieve optimal performance with a ground-mounted vertical, install as many radials as possible. These bulk radial wire kits use insulated wire that is UV resistant, hard to see and lays down easily, unlike the wire that is commonly available at the big box stores. It will last much longer in contact with soil than bare wire.

The DXE-RADW- 500K or 1000K kit provide everything you will need to build the perfect radial system!

- 500/1000 ft. spool of 14 AWG, stranded copper wire with vinyl insulation
- 20/40 lugs
- 100/200 radial wire anchor pins- Eliminating the need to bury your radials!
- Build up to 20/40 radials, 25 feet long



DXE-RADW-500K	Bulk Radial Wire Kit, 500 ft Spool of Wire, 20 Lugs, 100 Staples
DXE-RADW-1000K	Bulk Radial Wire Kit, 1000 ft Spool of Wire, 40 Lugs, 200 Staples

DXE-RADW-500KBD or 1000KBD - Bulk Radial Wire Kits and Components

To achieve optimal performance with a ground-mounted vertical, install as many radials as possible. These bulk radial wire kit use insulated wire that is UV resistant, hard to see and lays down easily, unlike the wire that is commonly available at the big box stores. It will last much longer in contact with soil than bare wire. The biodegradable anchors allow easy installation of radial wires, and will degrade and disappear in a year or so when they are no longer needed. The DXE-RADW-500 or 1000KBD kit provide everything you will need to build the perfect radial system!



- 500/1000 ft. spool of 14 AWG, stranded copper wire with vinyl insulation
- 20/40 lugs
- 100/200 biodegradable radial wire anchor pins- Eliminating the need to bury your radials!
- Build up to 20/40 radials, 25 feet long

DXE-RADW-500KBD	Bulk Radial Wire Kit, 500 ft Spool of Wire, 20 Lugs, 100 Biodegradable Staples
DXE-RADW-1000KBD	Bulk Radial Wire Kit, 1000 ft Spool of Wire, 40 Lugs, 200 Biodegradable Staples

DXE-225RT-20 - Ring terminal 16-14 Wire Gauge, 1/4" hole/20 Pack

This is a set of 20 ring terminals for AWG #14 to 16 wire with a clearance hole for a 1/4" bolt. These are the same crimp terminals supplied with the DXE Radial Wire Kits for #14 Radial and Antenna Wire.



DXE-RADW-65RT Pre-Assembled, 65 foot Radial Wires, w/ 1/4" ring Terminals, 20 Pack

The DXE-RADW-65T Radial Wire Kit include the highest quality 14 gauge stranded copper wire with a relaxed black PVC insulation for easy installation of your radial system. This allows fast and easy installation of your radial ground system. The stranded wire and relaxed insulation mean that the wire will lay flat as you place it on the ground - easy to install! The twenty 65 foot pre-cut radial wires include 1/4" ring terminals professionally crimped on one end for quick and easy attachment to the radial plate. This Radial Wire Kit is designed for users of vertical antenna systems which have the need for a high quality radial system for optimum antenna performance. The 1/4" ring terminals are machine crimped for maximum grip. Soldering is not required for strength, but is recommended if installed in corrosive environments such as salt spray.



- Packed 20 Radial Wires per package
- 14 gauge, stranded copper wire
- Black relaxed PVC insulation
- 1/4" Ring Terminal professionally crimped on each Radial Wire

DXE-STPL - Radial Wire Anchor Pins, 100/pack - No need to bury your radials!

DX Engineering Radial Wire Anchor Pins are perfect for fastening radials below the grass line to eliminate the risk of damaging your radials during lawn maintenance.

- 100 count - 6" Pins
- 11-Gauge

DXE-STPL-100P	Radial Wire Anchor Pins, 100/pack
DXE-STPL-300P	Radial Wire Anchor Pins, 300/pack

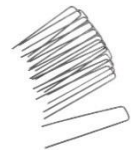

DXE-STPL-100BD - Radial Wire Staple, Biodegradable, 3", 100 pack

DX Engineering DXE-STPL-100BD is a 100-pack of 3" biodegradable anchors that are produced from recycled PLA (Polylactide Resin). Depending on the weather conditions, they will degrade in about a year. They are easily installed and will hold radial wires in place until lawn roots overtake them - and then disappear. Ecologically friendly!



SUM-900031 - Automatic Wire Stripper/Crimper/Cutter, 24-10 Ga.

Our DX Engineering wire stripper uses a spring-loaded design to make quick work of wires ranging from 24 to 10 gauge. Just insert the wire, squeeze the handle, and listen for the click. That's the sound of another perfect wire stripping job performed in about 2 seconds- a fraction of the time it takes your pocket knife to do the same job. An adjustable wire length guide helps you make uniform strips, and a built-in wire cutter and crimper helps you complete your wiring job.

- Spring-loaded design
- Strips wires ranging from 24 to 10 gauge
- built-in wire cutter and crimper



3M Temflex™ 2155 Rubber Splicing Tape

Conformable self-fusing rubber electrical insulating tape. It is designed for low voltage electrical insulating and moisture sealing applications. For outdoor use, it should be protected from UV deterioration with an overwrap of **Scotch Super 33+**.



Scotch® Super 33+

Highly conformable super stretchy tape for all weather applications. This tape provides flexibility and easy handling for all around performance. It also combines PVC backing with excellent electrical insulating properties to provide primary electrical insulation for splices up to 600V and protective jacketing. Both tape products are available from DX Engineering.



RigExpert® Antenna Analyzers

RigExpert® Antenna Analyzers are powerful antenna analyzers designed for testing, checking, tuning, or repairing antennas and antenna feed-lines. Mainly, these are SWR (Standing Wave Ratio) and impedance measurement instruments (vector impedance analyzers). Their large, bright LCD screens provide graphic illustration of SWR, impedance, return loss and much more. Easy-to use measurement modes, as well as additional features such as connection to a personal computer (to plot Smith charts, etc.), make RigExpert® analyzers attractive for professionals and hobbyists alike. The graphic display of various parameters over a wide frequency range is a key feature of these analyzers. This significantly reduces the time required to adjust an antenna. RigExpert® Antenna Analyzers are available in several models and in various frequency ranges of operation. Each is fitted with an SO-239 female connector, except for those models that will operate above 230 MHz, where a Type N connector is more efficient.

The following tasks are easily accomplished by using RigExpert® Antenna Analyzers:

- * Rapid check-out of an antenna
- * Tuning an antenna to resonance
- * Antenna SWR and impedance measurement
- * Making coaxial lines or measuring their parameters
- * Cable testing and fault location
- * Measuring capacitance or inductance of reactive loads

Rig Expert Antenna Analyzers: <https://www.dxengineering.com/search/product-line/rigexpert-antenna-analyzers?autoview=SKU&keyword=rig%20expert%20analyzers&sortby=BestKeywordMatch&sortorder=Ascending>

Technical Support

If you have questions about this product, or if you experience difficulties during the installation, contact DX Engineering at (330) 572-3200. You can also e-mail us at:

DXEngineering@DXEngineering.com

For best service, please take a few minutes to review this manual before you call.

Warranty

All products manufactured by DX Engineering are warranted to be free from defects in material and workmanship for a period of one (1) year from date of shipment. DX Engineering's sole obligation under these warranties shall be to issue credit, repair or replace any item or part thereof which is proved to be other than as warranted; no allowance shall be made for any labor charges of Buyer for replacement of parts, adjustment or repairs, or any other work, unless such charges are authorized in advance by DX Engineering. If DX Engineering's products are claimed to be defective in material or workmanship, DX Engineering shall, upon prompt notice thereof, issue shipping instructions for return to DX Engineering (transportation-charges prepaid by Buyer). Every such claim for breach of these warranties shall be deemed to be waived by Buyer unless made in writing. The above warranties shall not extend to any products or parts thereof which have been subjected to any misuse or neglect, damaged by accident, rendered defective by reason of improper installation, damaged from severe weather including floods, or abnormal environmental conditions such as prolonged exposure to corrosives or power surges, or by the performance of repairs or alterations outside of our plant, and shall not apply to any goods or parts thereof furnished by Buyer or acquired from others at Buyer's specifications. In addition, DX Engineering's warranties do not extend to other equipment and parts manufactured by others except to the extent of the original manufacturer's warranty to DX Engineering. The obligations under the foregoing warranties are limited to the precise terms thereof. These warranties provide exclusive remedies, expressly in lieu of all other remedies including claims for special or consequential damages. SELLER NEITHER MAKES NOR ASSUMES ANY OTHER WARRANTY WHATSOEVER, WHETHER EXPRESS, STATUTORY, OR IMPLIED, INCLUDING WARRANTIES OF MERCHANTABILITY AND FITNESS, AND NO PERSON IS AUTHORIZED TO ASSUME FOR DX ENGINEERING ANY OBLIGATION OR LIABILITY NOT STRICTLY IN ACCORDANCE WITH THE FOREGOING.

©DX Engineering 2021

DX Engineering®, DXE®, DX Engineering, Inc.®, Hot Rodz®, Maxi-Core®, DX Engineering THUNDERBOLT®, DX Engineering Yagi Mechanical®, EZ-BUILD®, TELREX®, Gorilla Grip® Stainless Steel Boom Clamps, Butternut®, SkyHawk™, SkyLark™, SecureMount™, OMNI-TILT™, RF-PRO-1B®, AFHD-4® are trademarks of PDS Electronics, Inc. No license to use or reproduce any of these trademarks or other trademarks is given or implied. All other brands and product names are the trademarks of their respective owners.

Specifications subject to change without notice.



DXE-160VA-1-INS