



# HEXXAGONAL BEAM

## Mark 2

**DXE-HEXX-5TAP-2, DXE-HEXX-1TAP-2**

DXE-HEXX-BEAM-MARK2-INS Rev. 2



© DX Engineering 2010

P.O. Box 1491 · Akron, OH 44309-1491 USA

Phone: (800) 777-0703 · Tech Support and International: (330) 572-3200

Fax: (330) 572-3279 · E-mail: [DXEngineering@DXEngineering.com](mailto:DXEngineering@DXEngineering.com)

## Table of Contents

<b>Introduction</b>	<b>2</b>
<b>HEXXAGONAL BEAM Mark 2 Features</b>	<b>5</b>
<b>HEXXAGONAL BEAM Kits</b>	<b>5</b>
<b>Parts Lists</b>	
<b>DXE-HEXX-1HBP - HEXX HUB (US Patent No. D605,184)</b>	6
<b>DXE-HEXX-1SCP-2 - HEXXAGONAL BEAM Spreader &amp; Center Post</b>	6
<b>DXE-HEXX-5FFP HEXXAGONAL BEAM 5-Band Stainless Steel/Teflon® Rigid Feeder System (patent pending)</b>	6
<b>DXE-HEXX-5WRP-2 - HEXXAGONAL BEAM 5-band Wire Element &amp; Wire Guide</b>	6
<b>DXE-HEXX-1WRP-2 - HEXXAGONAL BEAM 1-band Wire Element &amp; Wire Guide</b>	7
<b>Parts Required but not supplied</b>	<b>7</b>
<b>Tools Required</b>	<b>7</b>
<b>Manual Updates</b>	<b>7</b>
<b>HEXXAGONAL BEAM Construction</b>	<b>8</b>
Hexxagonal Hub Assembly Instructions	9
Working with Fiberglass	10
Center Post Assembly	11
5-Band Stainless Steel/Teflon® Rigid Feeder System (patent pending)	13
Installing the Center Post Rope Hub	14
Installing the optional Feedline Current Choke	16
Spreader Assembly	17
Installing the Wire Elements	22
Installation on a Mast and Rotator	26
SWR Testing	27
Single Band Wire Element and Wire Guide Package Instructions	28
<b>Optional Items</b>	<b>32</b>
<b>Technical Support</b>	<b>36</b>
<b>Warranty</b>	<b>36</b>

## Introduction

The DX Engineering **HEXXAGONAL BEAM KITS** provide a fast, economical way to build the hottest new design of an antenna concept that has been around since the 1980's. **HEXXAGONAL BEAM** component kits are available for an easy, step-by-step approach to designing your own antenna or to upgrade an existing installation.



The DX Engineering **HEXXAGONAL BEAM Mark 2** Five Band Hexagonal Beam Antenna Package is a complete build-it-yourself system, including pre-assembled wire element kits, assembled wire guide and rope attachment clamps and a revolutionary new Five-Band Stainless Steel/Teflon® Rigid Feeder System (*patent pending*) which operates all bands, 20 thru 10 meters with a single feedline. All hardware is high quality stainless steel. The pre-cut wire elements are 14 gauge stranded copper with black PVC insulation with special black wire guide tubes and ring terminals factory assembled. The rope supplied is a double-braided Dacron/Polyester, not weakened by decay or mildew and provides excellent resistance to abrasion. The color sealed black polyester yarn used in the braided jacket also protects the cord from damage due to ultra-violet light. The fiberglass spreaders are measured and cut to length with pre-cut slits on one end for proper tightening using the stainless steel band clamps. Also included is the complete DX Engineering Hexx Hub (patented). The cast aluminum Hexxagonal Beam Hub provides a superior mounting platform with built-in v-saddle clamping channels and all stainless steel v-bolts and hardware are included.



The DX Engineering **HEXXAGONAL BEAM Mark 2** can offer gain and front-to-back performance that exceeds your expectations for a multi-band two element beam, as its unique shape is much smaller, better balanced and has been reported to receive less noise than typical beams. This lighter, easier to handle antenna can be rotated with a light duty rotator, and it performs well, even when it is not mounted very high above the ground. With the DX Engineering **HEXXAGONAL BEAM Mark 2** and kits you can build your antenna with a broadband, u-shaped reflector for better coverage of the bands with low SWR. This is only one of the dramatic improvements of the G3TXQ broadband design over the "classic" dual-w hex beam antennas.



The Five Band Stainless Steel/Teflon® Rigid Feeder System is a revolutionary breakthrough for Hexagonal Beam Antennas!

This new patent pending Stainless Steel/Teflon® Rigid Feeder System eliminates vulnerable coaxial cable feedpoint sections - providing a weatherproof, low-loss, high power balanced connection to all bands for optimum antenna pattern control. This revolutionary Rigid Feeder

attaches directly to the outside of the full-size 1-1/4" fiberglass Center Post. It is no longer necessary to drill or slice up a center post - weakening it - to attach or protect older coaxial cable feeders with homebrew or terminal strip connections.

The integral center insulators with the unique serpentine wire grip assure long, reliable performance. The pre-assembled and tested Five Band Stainless Steel/Teflon® Rigid Feeder System is also ideal for retrofitting to other, older hexagonal beam designs using the DX Engineering wire element dimensions - or with your own hex antenna with appropriate testing and modifications.

At the center of the new **HEXXAGONAL BEAM Mark 2** is the exclusive DX Engineering cast aluminum HEXX Hub (US Patent No. D605,184). Specially designed and mechanically superior to available home-made base plate designs, the HEXX Hub has integral V-saddles and Stainless Steel V-Bolt hardware to firmly attach the fiberglass spreaders in proper alignment without drilling or crushing. The upper and lower mast mounts are integrally cast into the hub, eliminating the need to find separate mounting flanges, reducing assembly time, improving mast alignment and providing a far stronger, heavy duty attachment for the mast. For the rest of the antenna frame, high quality stainless steel element clamps rigidly hold the telescoping fiberglass sections at the correct lengths without drilling holes. Exclusive DX Engineering stainless steel element clamps with studs provide secure attachment points for the Five Band Stainless Steel/Teflon® Rigid Feeder System without drilling. The unique Floating Element Wire Guides allow independent movement of the radiating wire elements and flexible fiberglass spreaders in the wind without creating breaking stresses. These special Wire Guides are attached to the spreaders without drilling, for a stronger, longer lasting antenna.



The DX Engineering **HEXXAGONAL BEAM Mark 2** is a directional beam antenna made with fiberglass spreaders and wire elements that looks like a very large inverted umbrella frame. Even at 22 feet wide and approximately 5 feet tall, it has a smaller turning radius than a two element 20 meter Yagi, and offers several enhanced operating characteristics. It may be mounted at the top of a rotatable mast or directly into a light to medium duty rotator. This antenna is fed at the top of the center post with a single 50 ohm feedline. This top fed feedline arrangement has been tested and proven to function better than a bottom feedpoint connection.

## HEXXAGONAL BEAM Features

The DX Engineering **HEXXAGONAL BEAM Mark 2** design has a number of important advantages over a yagi:

- **Small turning radius** - the **HEXXAGONAL BEAM Mark 2** has a turning radius of 11'
- **Gain** - 5 dBi (3 dBd), depending on band - similar to 2 element Yagi, far exceeding performance of multi-band mini-beams
- **Front-to-Back** - >20 dB, depending on band
- **Balanced in the wind** - Hexxagonal symmetry reduces torque on the rotor
- **Light weight** - fully assembled - less than 25 pounds
- **Wind load** - less than 5 square feet
- **Can be turned with a light duty rotator** - no need to spend big dollars
- **Performs well at low heights** - good results at 20 to 30 feet above ground
- **Five Band gain and front-to-back** - can meet or exceeds other small antennas
- **Handles full legal limit power** – no power restriction as on competing antennas
- **Low Noise results** - approaches performance of closed loop antennas
- **Has full length pre-cut elements** - no lossy coils or traps
- **Five-Band Stainless Steel/Teflon<sup>®</sup> Rigid Feeder System** (*patent pending*)
- **Requires no matching network** - direct single 50 ohm coax feed
- **New, easier and faster assembly** - fewer parts to speed completion of the antenna project

## HEXXAGONAL BEAM Kits

**DXE-HEXX-5TAP-2** - The DX Engineering **HEXX BEAM Mark 2 - Five-Band Total Antenna Package** consists of these four kits:

<b>DXE-HEXX-1HBP</b>	<b>HEXXAGONAL BEAM</b> Hub package ( <i>US Patent No. D605,184</i> )
<b>DXE-HEXX-1SCP-2</b>	<b>HEXXAGONAL BEAM</b> Spreader & Center Post package
<b>DXE-HEXX-5FFP</b>	<b>HEXXAGONAL BEAM</b> 5-Band Stainless Steel/Teflon <sup>®</sup> Rigid Feeder System ( <i>patent pending</i> )
<b>DXE-HEXX-5WRP-2</b>	<b>HEXXAGONAL BEAM</b> 5-band Wire Element & Wire Guide package

**DXE-HEXX-1TAP-2** - The DX Engineering **HEXX BEAM 1-Band Total Antenna Package** consists of these three kits:

<b>DXE-HEXX-1HBP</b>	<b>HEXXAGONAL BEAM</b> Hub package (US Patent No. D605,184)
<b>DXE-HEXX-1SCP-2</b>	<b>HEXXAGONAL BEAM</b> Spreader & Center Post package
<b>DXE-HEXX-1WRP-2</b>	<b>HEXXAGONAL BEAM</b> 1-band Wire Element & Wire Guide package

## Parts Lists

### DXE-HEXX-1HBP - HEXX HUB

Qty	Description
1	Cast Aluminum Hexxagonal Hub (US Patent No. D605,184)
12	1.5" short Stainless Steel V-Bolt
12	1/4-20 Stainless Steel Hardware Kit for V-Bolts
6	1/4-20 Stainless Steel Hex Head Bolt 1.5" long
6	1/4-20 Stainless Steel Hex Nut
6	1/4-20 Stainless Steel Flat Washer
6	1/4-20 Stainless Steel Split Washer

### DXE-HEXX-1SCP-2 - HEXXAGONAL BEAM Spreader & Center Post

Qty	Description
1	Fiberglass Tube, Gray, 1.25" OD x 58" Long, .120 Wall (for the Center Post)
6	Fiberglass Tube, Gray, 1.00" OD x 58" Long, .120 Wall with slits
6	Fiberglass Tube, Gray, 0.75" OD x 43" Long, .120 Wall with slits
6	Fiberglass Tube, Gray, 0.75" OD x 5" Long, .120 Wall
6	Fiberglass Tube, Gray, 0.50" OD x 48" Long, .120 Wall
1	Tube, Antenna, Aluminum, 1.375" OD x 14" Long, Slit one end (for the Center Post)
6	<b>DXE-ECL-10SS</b> - Element Clamp for 1" and 1.125" OD tubing
6	<b>DXE-ECL-060</b> - Element Clamp for .75" and smaller OD tubing
1	<b>DXE-ECL-16SS</b> - Element Clamp for 1.375" and 1.5" OD tubing
1	Vinyl End Cap, Black
2	<b>STI-DBR-94-100</b> - Dacron/Polyester Rope, 100 Foot Roll
6	Spreader Rope Connection Assembly w/cushioned P-Clamps mounted on Stainless Steel Band Clamps
1	Center Post Rope Connection Assembly - includes the following parts:
1	<b>DXE-MPH-1</b> Multi-Purpose Hub 1.5"
3	1/4-20 x 1.25" Stainless Steel Hex Head Bolt
3	1/4-20 Stainless Steel Nut
3	1/4-20 Stainless Steel Square Nut
3	1/4" Stainless Steel Split Washer
3	1/4" Stainless Steel Flat Washer, 18-8

### DXE-HEXX-5FFP - HEXXAGONAL BEAM 5-Band Stainless Steel/Teflon<sup>®</sup> Rigid Feeder System (*patent pending*)

Qty	Description
1	Five Band Stainless Steel/Teflon <sup>®</sup> Rigid Feeder ( <i>patent pending</i> )
1	Coaxial cable feedpoint pigtail
1	UHF Female-to-Female Adapter (dual SO-239 type)

### DXE-HEXX-5WRP - HEXXAGONAL BEAM 5-band Wire & Wire Guide

Qty	Description
2	20/17/15/12/10 Meter Wire Driven Element Sets - #14 Copper Stranded Wire with Black PVC Insulation with Ring Terminals attached and Wire Guides installed
1	20/17/15/12/10 Meter Wire Reflector Element Sets - #14 Copper Stranded Wire with Black PVC Insulation with Ring Terminals attached and Wire Guides installed
15	#10 hole, 16-14 Wire Gauge Ring Terminal (Spares for various bands and/or adjustment in element lengths)
12	Floating Wire Guides for 1/2" Spreader
18	Floating Wire Guides for 3/4" Spreader

## DXE-HEXX-1WRP HEXXAGONAL BEAM 1-band Wire & Wire Guide

Qty	Description
2	20 Meter Wire Driven Element - #14 Copper Stranded Wire with Black PVC Insulation with Ring Terminals attached and Wire Guides installed
1	20 Meter Wire Reflector Element - #14 Copper Stranded Wire with Black PVC Insulation with Ring Terminals attached and Wire Guides installed
6	#10 hole, 16-14 Wire Gauge Ring Terminal (Spares for various bands and/or adjustment in element lengths)
1	UHF Female-to-Female Adapter (dual SO-239 style)
1	Coax Wire Assembly, 10" with PL-259 and Ring Terminals
1	Single Band Feeder Insulator Clamp Assembly
6	Floating Wire Guides for 3/4" Spreader.

### Parts Required but not supplied

**DXE-81343** - Anti-Seize, 1 oz. Squeeze Tube - or -

**DXE-NSBT8** - Never-Seez, 8 oz. Brush Top - or -

**DXE-NMCBT8** - Never-Seez, 8 oz. Brush Top, Mariner's Choice

**The above products are limited to domestic UPS Ground shipping only**

Note: Anti-Seize or Never Seez should be used to prevent galling (seizing) of stainless steel hardware.

**DXE-3M2155** - 3M Temflex™ 2155 Rubber Splicing Tape

**DXE-33PLUS** - Scotch® Super 33+ Tape

The **DXE-FCC050-H05-A** - Feedline Current Choke and the **DXE-BMB-1P** Balun Mounting Kit for a .750 in. thru 1.50 in. Boom - are suggested options and this manual describes their installation.

### Tools Required

1/4", 5/16", 3/8" and 7/16" Deep Well Nut Drivers and/or Open End Wrenches

Tape Measure, 50 ft

Step Ladder, 6 ft. *Use proper precautions for step ladder safety*

Screwdriver

Pliers

Scissors

Lighter or flame source (to slightly melt the cut rope ends to keep them from fraying)

*Use proper safety precautions for a lighter or flame producing item*

Marking Pen or Pencil

Three foot Tripod and three foot mast pipe - To hold the antenna while under construction.

### Manual Updates

Every effort is made to supply the latest manual revision with each product. Occasionally a manual will be updated between the time your DX Engineering product is shipped and when you receive it. Please check the DX Engineering web site ([www.dxengineering.com](http://www.dxengineering.com)) for the latest revision manual.

## HEXXAGONAL BEAM Construction

This manual for the DX Engineering **HEXXAGONAL BEAM Mark 2** is written in sections for the various assemblies. Each section of assembly instructions is titled with the **HEXXAGONAL BEAM Mark 2** kit name and model number for easy reference.

The typical build sequence is:

1. Assemble the patented HEXX HUB
2. Center Post assembly
3. 5-Band Stainless Steel/Teflon<sup>®</sup> Rigid Feeder System (*patent pending*) Installation
4. Install the Center Post Rope Hub
5. Installation of the optional **DXE-FCC050-H05-A** Feedline Current Choke
6. Spreader assembly
7. Wire Element installation
8. Installation on a Mast and Rotator
9. SWR Testing

An outdoor area of about a minimum 30 foot square is required for assembly of this antenna.

The use of a three foot tripod and a three foot mast pipe makes construction of the antenna easier (see **Figure 1**).



**Figure 1 - Using a temporary tripod and mast for assembly at ground level**

Sufficient space is required for the installation of the antenna on your mast or tower. The finished antenna is approximately 22 feet in diameter.



# Hexxagonal Hub Assembly Instructions

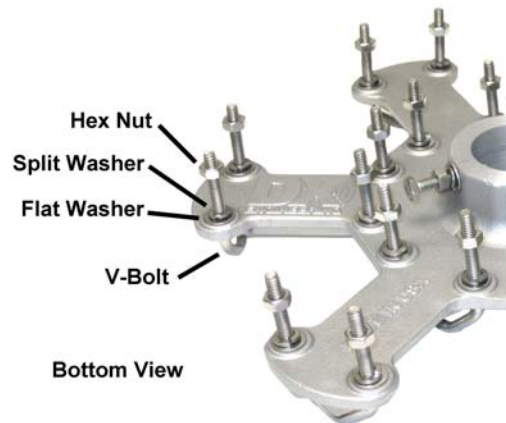
## DXE-HEXX-1HBP - HEXXAGONAL HUB (US Patent No. D605,184) Parts List

Qty	Description
1	Cast Aluminum Hexxagonal Hub (US Patent No. D605,184)
12	1.5" short Stainless Steel V-Bolt
12	1/4-20 Stainless Steel Hardware Kit for V-Bolts
6	1/4-20 Stainless Steel Hex Head Bolt, 1.5" long
6	1/4-20 Stainless Steel Hex Nut
6	1/4-20 Stainless Steel Flat Washer
6	1/4-20 Stainless Steel Split Washer

Insert the twelve Stainless Steel V-Bolts over the cast V-Saddles as shown in **Figure 2**.



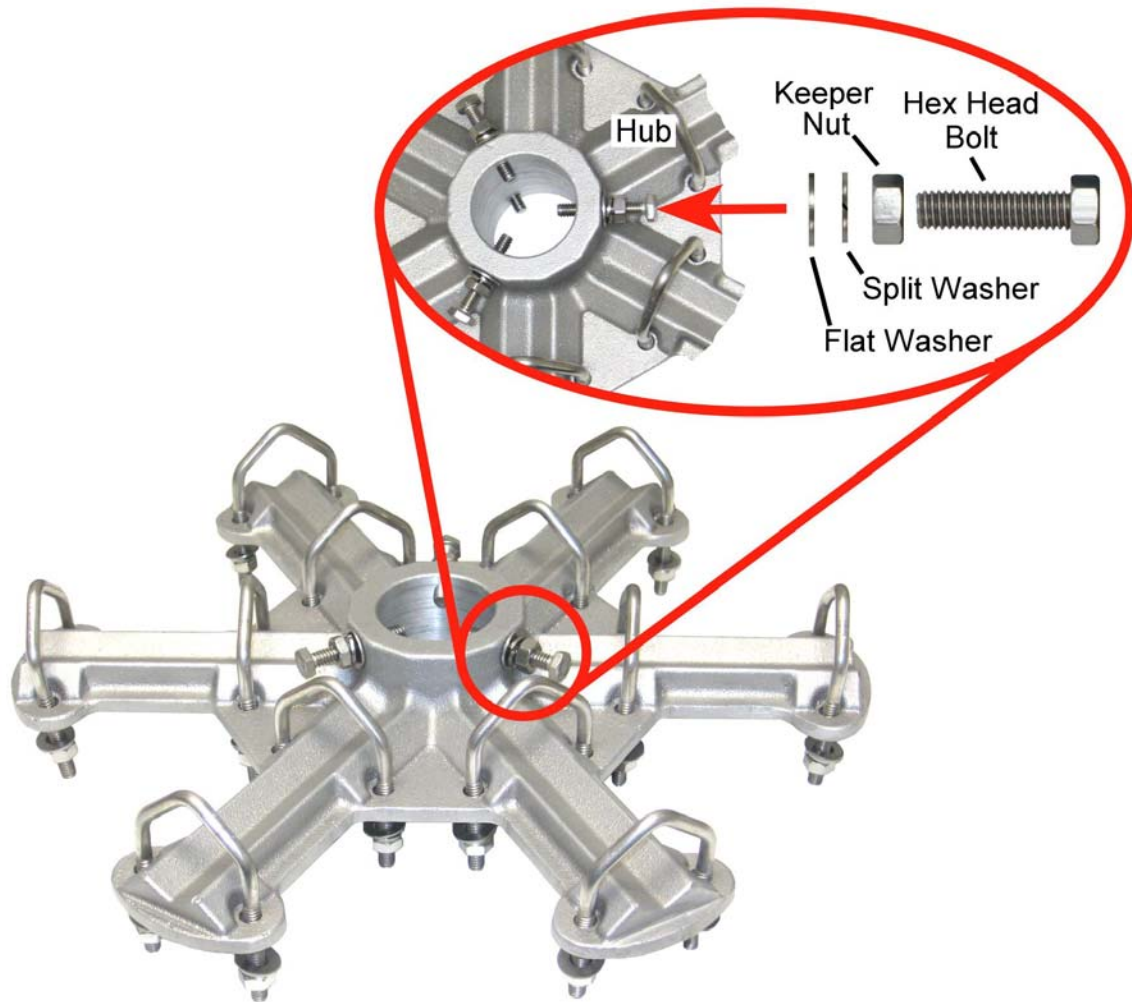
**Figure 2**



*Anti-Seize or Never Seez should be used to prevent galling (seizing) of stainless steel hardware.*

Install a flat washer, a split washer and a 1/4-20 nut on each V-Bolt leg, snug the nuts partially.

Install six 1/4 -20 bolts, six flat washers, six split washers and six nuts, into the top and bottom cast-in flanges of the hub, as shown in **Figure 3**. These will be adjusted to fit the center post for the **HEXXAGONAL BEAM**.



**Figure 3**

The DX Engineering Hexxagonal Hub is now ready for use as the solid foundation for your **HEXXAGONAL BEAM Mark 2**.

## **Working with Fiberglass**

**NOTE:** Extra effort during production is accomplished to clean fiberglass dust from the fiberglass parts. However, some fiberglass dust may remain. As a precaution, gloves, a dust mask and eye protection should be worn when unpacking, handling and cleaning (with a damp cloth) the fiberglass spreader tubes. This should be done outdoors so fiberglass dust will not collect indoors.

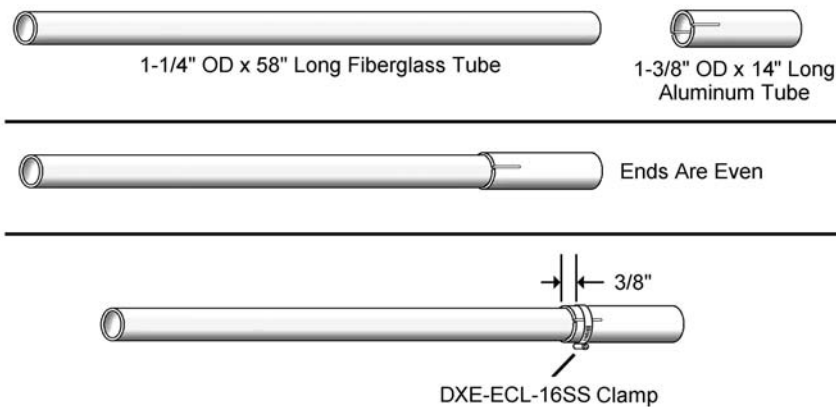
# Center Post and Spreader Assembly Instructions

## DXE-HEXX-1SCP-2 - HEXXAGONAL BEAM Spreader & Center Post Parts List

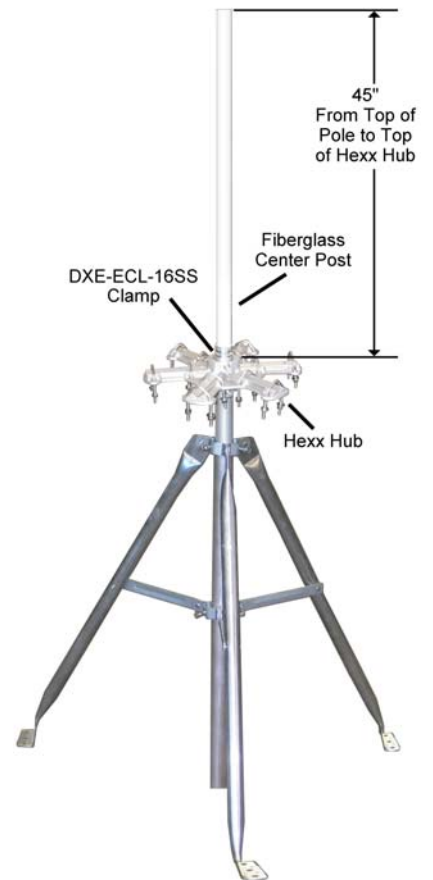
Qty	Description
1	Fiberglass Tube, Gray, 1.25" OD x 58" Long, .120 Wall (for the Center Post)
6	Fiberglass Tube, Gray, 1.00" OD x 58" Long, .120 Wall with slits
6	Fiberglass Tube, Gray, 0.75" OD x 43" Long, .120 Wall with slits
6	Fiberglass Tube, Gray, 0.75" OD x 5" Long, .120 Wall
6	Fiberglass Tube, Gray, 0.50" OD x 48" Long, .120 Wall
1	Tube, Antenna, Aluminum, 1.375" OD x 14" Long, Slit one end (for the Center Post)
6	<b>DXE-ECL-10SS</b> - Element Clamp for 1" and 1.125" OD tubing
6	<b>DXE-ECL-060</b> - Element Clamp for .75" and smaller OD tubing
1	<b>DXE-ECL-16SS</b> - Element Clamp for 1.375" and 1.5" OD tubing
1	Vinyl End Cap, Black
2	<b>STI-DBR-94-100</b> - Dacron/Polyester Rope, 100 Foot Roll
6	Spreader Rope Connection Assemblies with cushioned p-clamps installed
1	Center Post Rope Connection Assembly - includes the following parts:
1	<b>DXE-MPH-1</b> Multi-Purpose Hub 1.5"
3	1/4-20 x 1.25" Stainless Steel Hex Head Bolt
3	1/4-20 Stainless Steel Nut
3	1/4-20 Stainless Steel Square Nut
3	1/4" Stainless Steel Split Washer
3	1/4" Stainless Steel Flat Washer, 18-8

## Center Post Assembly

Assemble the one 1-1/4" OD x 58" long fiberglass center post tube into the one 1-3/8" x 14" long aluminum tube, with the slit end of the aluminum tube oriented toward the middle of the center post. The other end of the aluminum tube is aligned flush with the end of the fiberglass center post. Secure the two parts together using the **DXE-ECL-16SS** Element Clamp over the slits with a 3/8" spacing between the end of the slit end of the aluminum tube to the element clamp as shown in **Figure 4**.



**Figure 4**

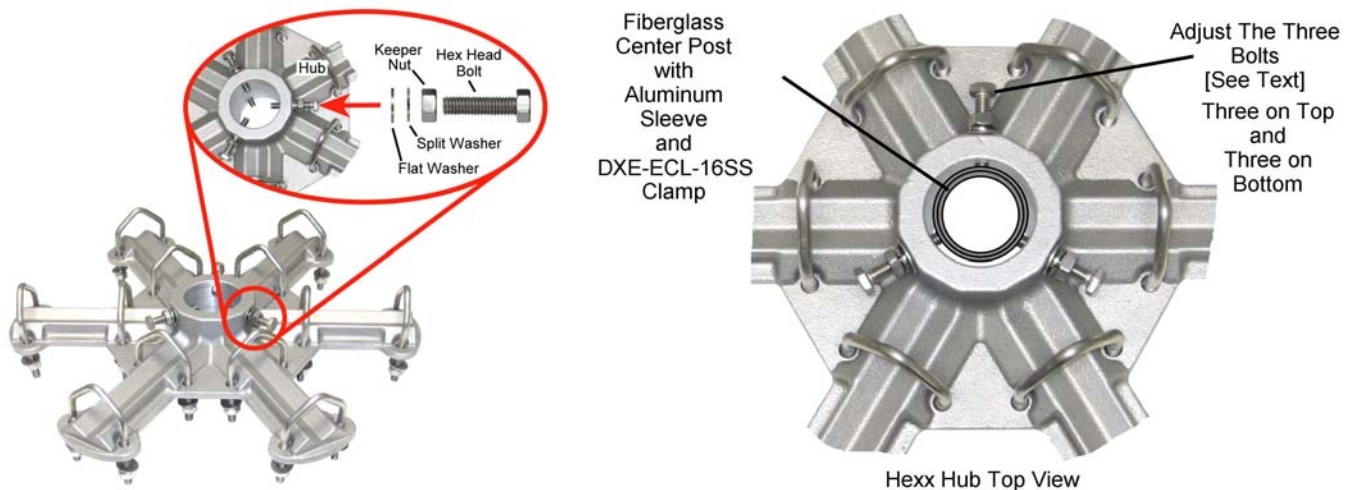


Insert the center post with aluminum tube sleeve into the Hexxagonal Hub. The height of the center post should be 45" above the top of the Hexx Hub as shown in **Figure 4**.

Hand tighten the upper and lower mast mount hardware on the Hexxagonal Hub evenly, to position the post *exactly in the center* of the hub. Make certain that the plane of the hub is perpendicular to the post so the post and hub are concentrically spaced through the hub with the mast mount hardware equally tightened. Tighten the mast mount bolts progressively, but carefully, to maintain even spacing between the post and the hub upper and lower mast mounts as shown in **Figure 5**.

The mast mount bolts should be tightened firmly to secure the hub, but not enough to dent the aluminum tubing. Final position of these bolts is maintained by tightening the keeper nuts only until the split washers are flat while keeping the mast mount bolts from turning further.

Once assembled, you can use a customer supplied 3 foot tube that will fit over the 1/38" OD aluminum tube that sticks below the bottom of the Hexxagonal Hub and tripod as shown in **Figure 4**, to aid in assembling the antenna system at ground level.



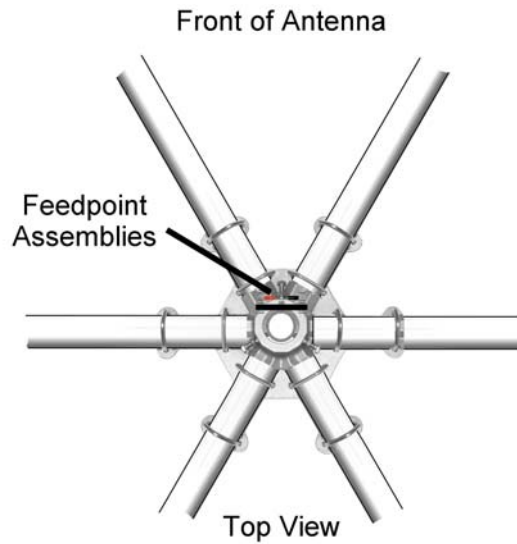
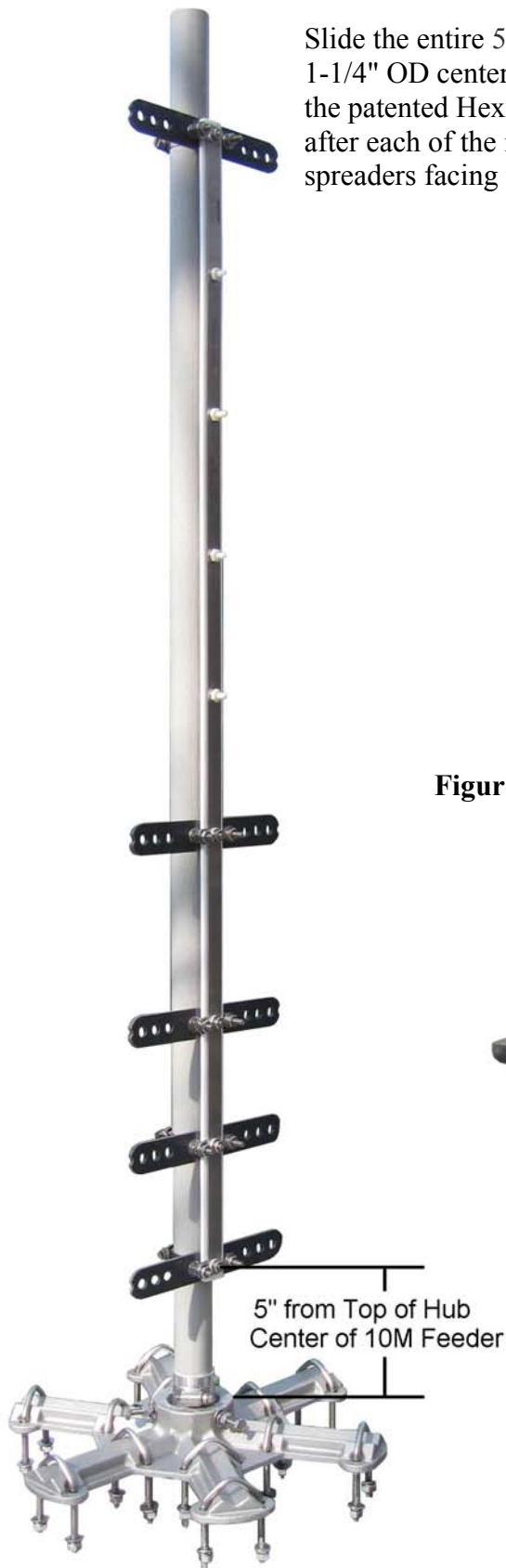
**Figure 5**

If you are building the DX Engineering **HEXXAGONAL BEAM 1-Band Total Antenna Package - DXE-HEXX-1TAP-2**, skip the section titled **5-Band Stainless Steel/Teflon® Rigid Feeder System installation**. Install the Rope Hub and Spreaders as described in the sections titled **Installing the Center Post Rope Hub** and the **Spreader Assembly**. The Single Feed system is described in the section titled: **DXE-HEXX-1WRP-2 One-Band Wire and Wire Guide Package (page 28)**.

If you are building the DX Engineering **HEXXAGONAL BEAM Mark 2 Five-Band Total Antenna Package - DXE-HEXX-5TAP-2** continue below.

## 5-Band Stainless Steel/Teflon<sup>®</sup> Rigid Feeder System installation

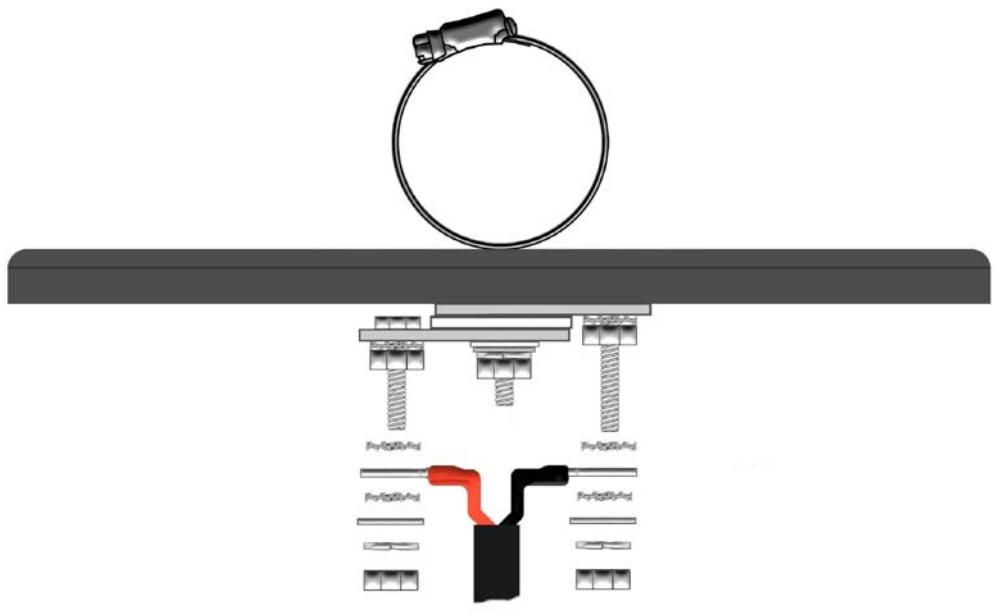
Slide the entire 5-Band Stainless Steel/Teflon<sup>®</sup> Rigid Feeder System onto the 1-1/4" OD center post. Position the center of the 10 meter insulator 5" above the patented Hexx Hub (**DXE-HEXX-1HBP**). Tighten the insulator clamps after each of the insulators are aligned to face directly between the two spreaders facing the front of the antenna, as shown in **Figure 6**.



**Figure 6**



Install the Coaxial Cable pigtail to the top (20 meter) feedpoint on the Five Band Stainless Steel/Teflon® Rigid Feeder as shown in **Figure 7**. The Five Band Stainless Steel/Teflon® Rigid Feeder is factory assembled with all hardware. You will have to remove and re-use some of the nuts, washers and lock washers to install the pigtail. Later on you will also remove and re-use hardware when installing the driven element wires.



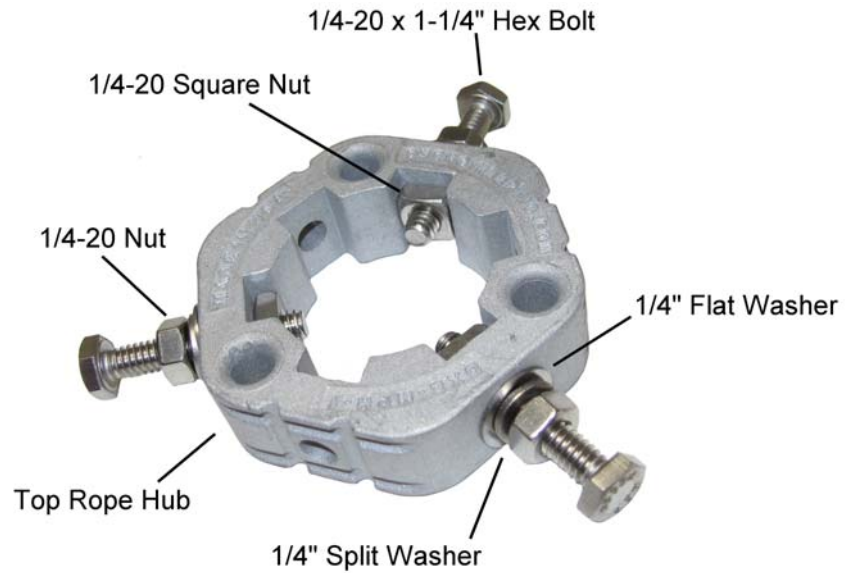
**Figure 7**



## Installing the Center Post Rope Hub

Using **Figure 8** as a reference, assemble the center post rope connection hub assembly with hardware.

**Figure 8**



Install center post rope connection hub assembly, 1-1/2" from the top of the center post as shown in **Figure 9**. Orient this hub so its vertical holes are facing between every other spreader. Tighten the hub hardware carefully so the center post and the hub are concentric (space between the center post and the interior of the hub is even). When tightened to the center post, lock the hex head bolts in place by tightening the 1/4-20 hex nuts against the hub. Install the 1-1/4" black vinyl cap on the top of the center post.



**Figure 9**

## Installing the optional Feedline Current Choke

Using the optional **DXE-BMB-1P**, attach the long aluminum strip to the bottom of the optional **DXE-FCC050-H05-A** Feedline Current Choke. Place the Feedline Current Choke on the Center Post using the two stainless steel band clamps (included with the **DXE-BMB-1P**). One clamp is located below the 20 meter feed point clamp and the lower band clamp is located above the 17 meter element clamp as shown in **Figure 10**. Connect the coaxial pigtail to the top of the Feedline Current Choke. If the optional Feedline Current Choke is not installed, use the supplied UHF to UHF adapter to connect your RG-213 (or equivalent) coaxial cable to the feedline pigtail.



Figure 10



## Spreader Assembly

Locate the 25 fiberglass tubes. They are nested inside each other in the shipping box as shown in **Figure 11**.

- One 1-1/4" x 58" long fiberglass tube used for the center post assembly.
- Six 1" OD x 58" long fiberglass tubes slit on one end for the spreaders.
- Six 3/4" OD x 43" long fiberglass tubes slit on one end for the spreaders.
- Six 1/2" OD x 48" long fiberglass tubes for the spreaders.
- Six 3/4" OD x 5" long fiberglass tubes used to re-enforce the 1" OD tubes when mounted in the Hexx Hub.



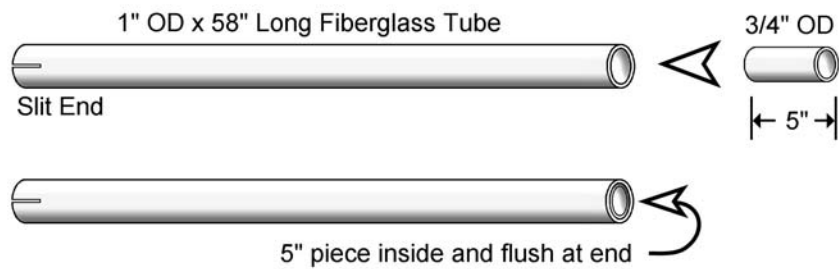
#	Qty	Fiberglass Tubes
①	1	1.25" OD x 58" Long
②	6	1.00" OD x 58" Long Slit One End
③	6	0.75" OD x 43" Long Slit One End
④	6	0.50" OD x 48" Long
⑤	6	0.75" OD x 5" Long

**Figure 11 - Fiberglass Tubes**

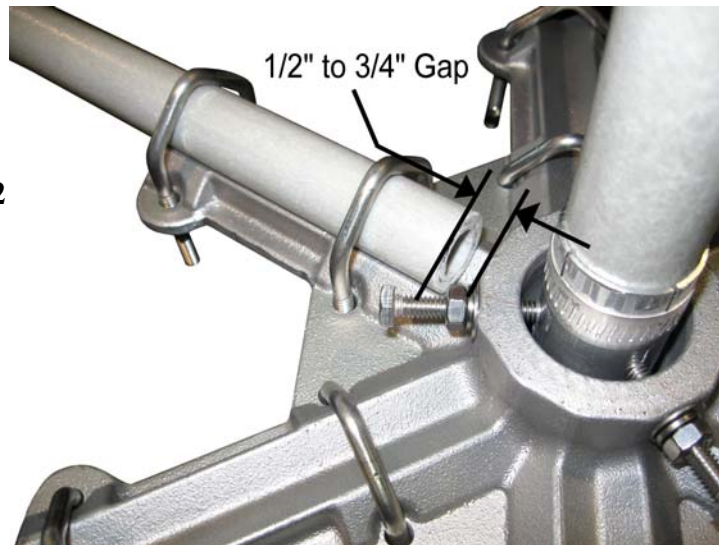
For ease of assembly and adjustment of the spreaders each element clamp tightening nut should be under the spreader as you look down on the antenna.

Insert a 3/4" OD x 5" long fiberglass reinforcement tube flush into the un-slit end of each of the six 1" OD x 58" long fiberglass sections. When the 1" OD is slid into the one of the six Hexxagonal Hub V-Saddle channels, under the V- Bolts ensure the smaller 5" long tube inside stays at the end. These short 5" pieces are being used to re-enforce the 1" tube under the V-Bolts.

Leave a space of about 1/2" to 3/4" between the upper mast mount surface of the hub and the end of each 1" OD spreader section. The slits at the far end should be aligned horizontally , not vertically. Ensuring the inside tube does not move, tighten the V-bolt nuts evenly until the lock washers are flattened, without crushing the section as shown in **Figure 12**.

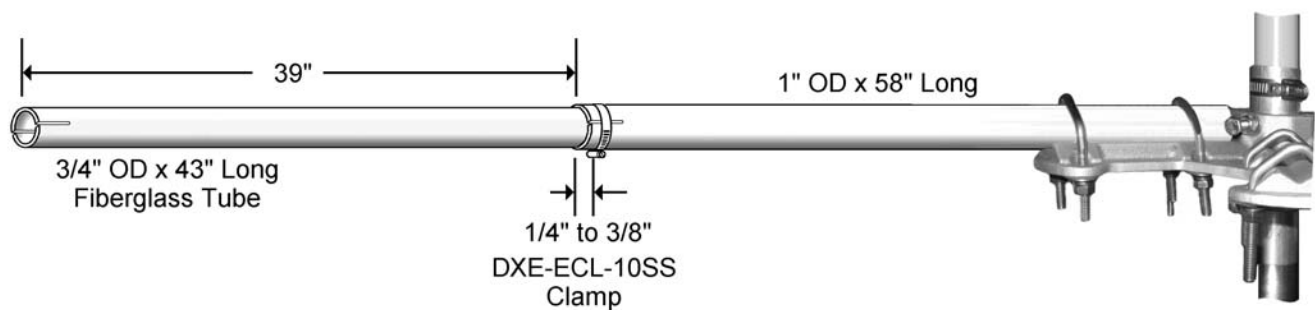


**Figure 12**



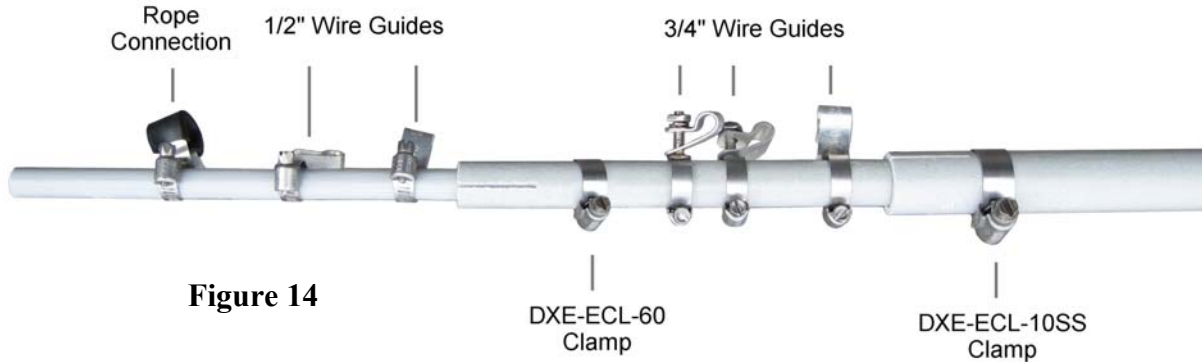
Place one **DXE-ECL-10SS** on each slit end of the six 1" OD sections. Slide the 3/4" OD x 43" long sections into the 1" sections and clamp them together, adjusting the 3/4" section to 39" in length as shown in **Figure 13**.

Ensure the slit ends are horizontally aligned, not vertical. Position the element clamp about 1/4" to 3/8" away from the end of the section when tightening. Do not over-tighten which will damage the element clamp. The clamp tightening screw should be on the bottom of the tube assembly.



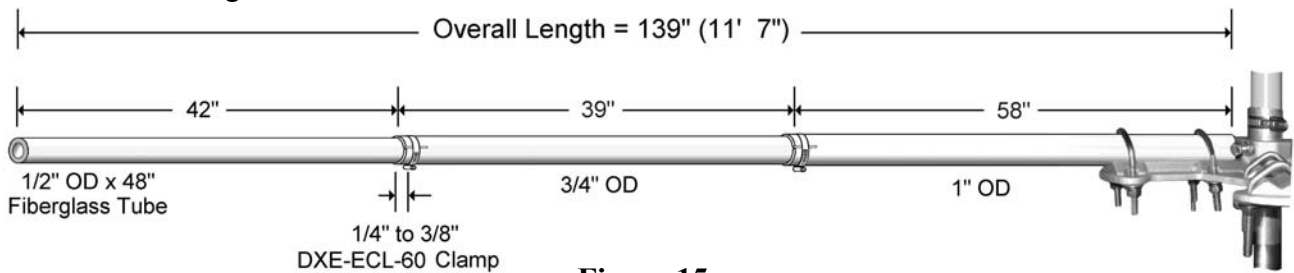
**Figure 13**

Slide the 1/2" OD x 48" long fiberglass section into the 3/4" fiberglass sections. Referring to **Figure 14** for each spreader, slide the three 3/4" wire element guides, the **DXE-ECL-60** band clamp, the two 1/2" wire element guides and the Rope Connection clamps as shown.



**Figure 14**

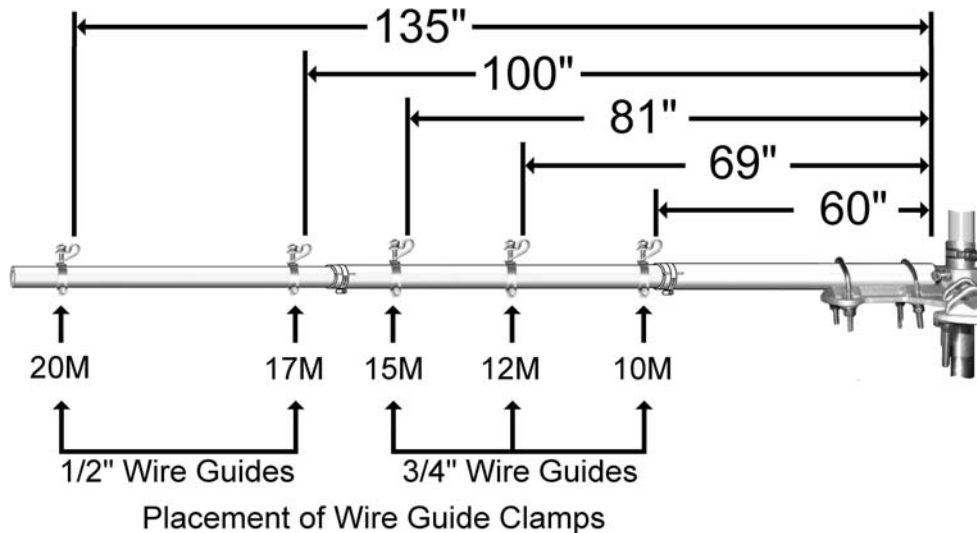
For each spreader, slide the 3/4" fiberglass section out of the 1" OD section to 39" as shown in **Figure 15**. Tighten the **DXE-ECL-10SS**. Slide the 1/2" OD long fiberglass section out of the 3/4" OD sections to 42" as shown in **Figure 15** and tighten the **DXE-ECL-60** clamp. Position the element clamps about 1/4" to 3/8" away from the end of the section when tightening. Do not over-tighten which will damage the element clamp. The clamp tightening screw should be on the bottom of the tube assembly. When completed, the three long sections (or tubes) making up one spreader will be 139" in length.



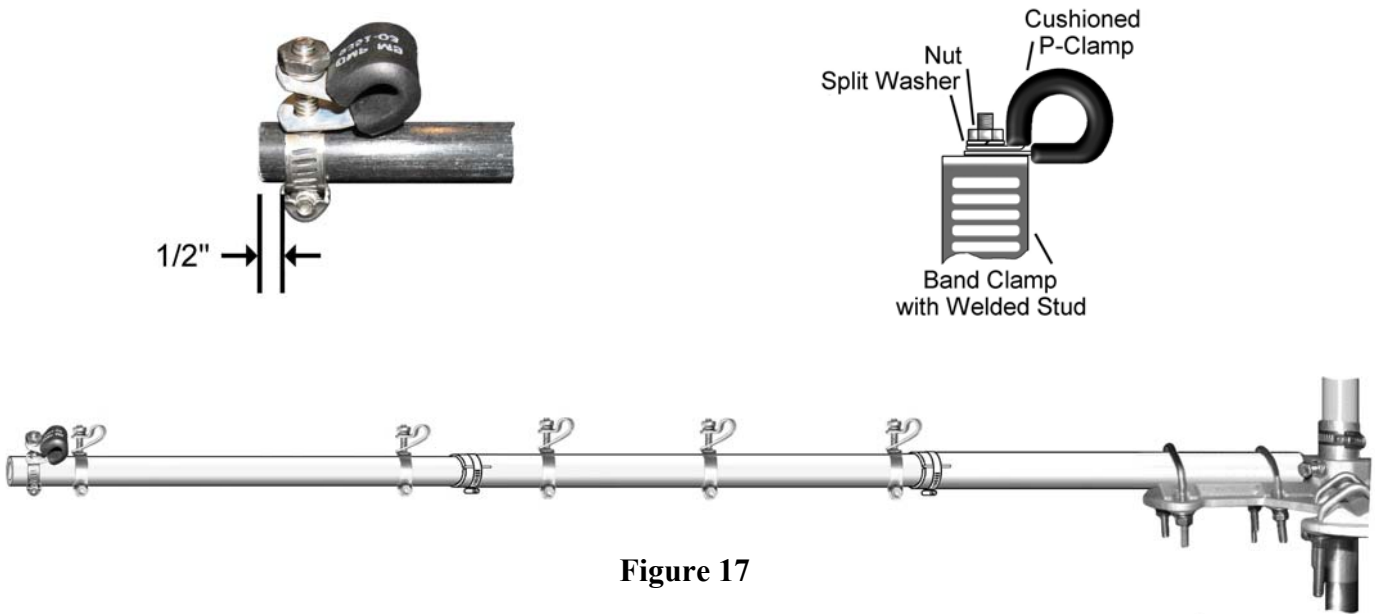
**Figure 15**

Place and tighten the wire guides as shown in **Figure 16** on the spreaders positioned vertically (P-Clamp up with loop toward the Hexx Hub - center of the antenna). These assemblies may be moved for final positioning on your antenna. Snug the band clamps in place and do not tighten.

**Figure 16**



Tighten each spreader rope connection assembly 1/2 " from the end of each spreader and tighten with the clamp stud and cushioned p-clamp are positioned vertically as shown in **Figure 17**.



**Figure 17**

The Dacron Polyester rope that came with the **Spreader and Center Post Package** may now be cut into specific lengths for the antenna assembly. After cutting this type of rope, the end should be slightly melted with a flame to prevent unraveling. The dimensions indicated include extra length for knots. Upon completion of the antenna, excess rope may be trimmed and re-melted.

Cut seven pieces of spreader support rope 136" in length (11' 4").

Cut one piece of rope 72" in length (6').

Cut one piece of rope 106" in length (8' 10").

Cut 10 element spacer ropes (2 for each band) to the 'cut lengths' dimensions in **Table 1**.

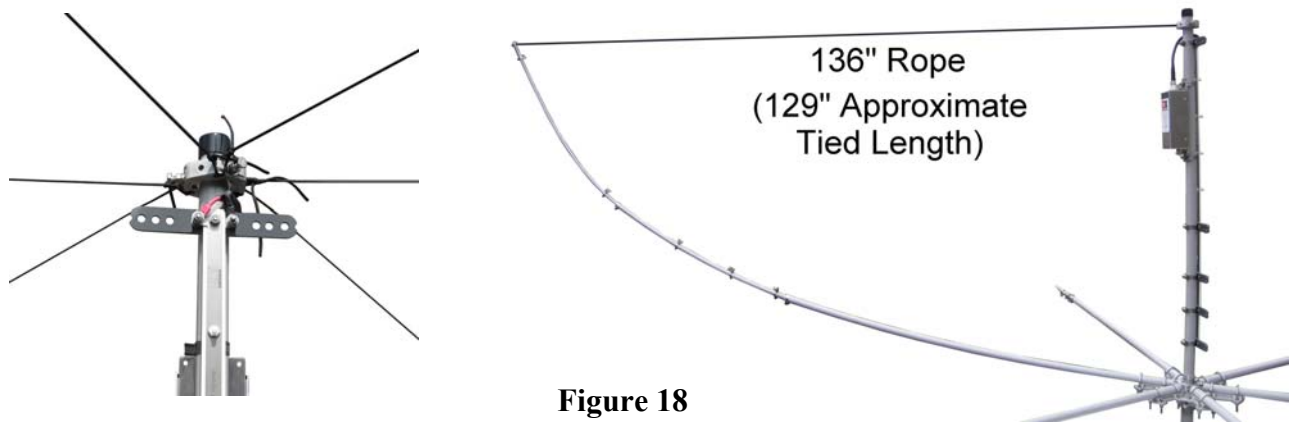
Band	Element Spacer Ropes Cut Length	Element Spacer Ropes Tied Length
20	30"	23-1/2"
17	24"	18"
15	22"	15-1/2"
12	20"	13-1/4"
10	18"	11-3/4"

**Table 1 - Element Spacer Ropes**

**Caution:** Bowed fiberglass spreaders can cause injury if they are accidentally released. Be sure helpers are not in the proximity of a bowed spreader during assembly.

Attach the 136" spreader support ropes onto each spreader rope connection assembly, knotting through and around the cushioned p-clamp.

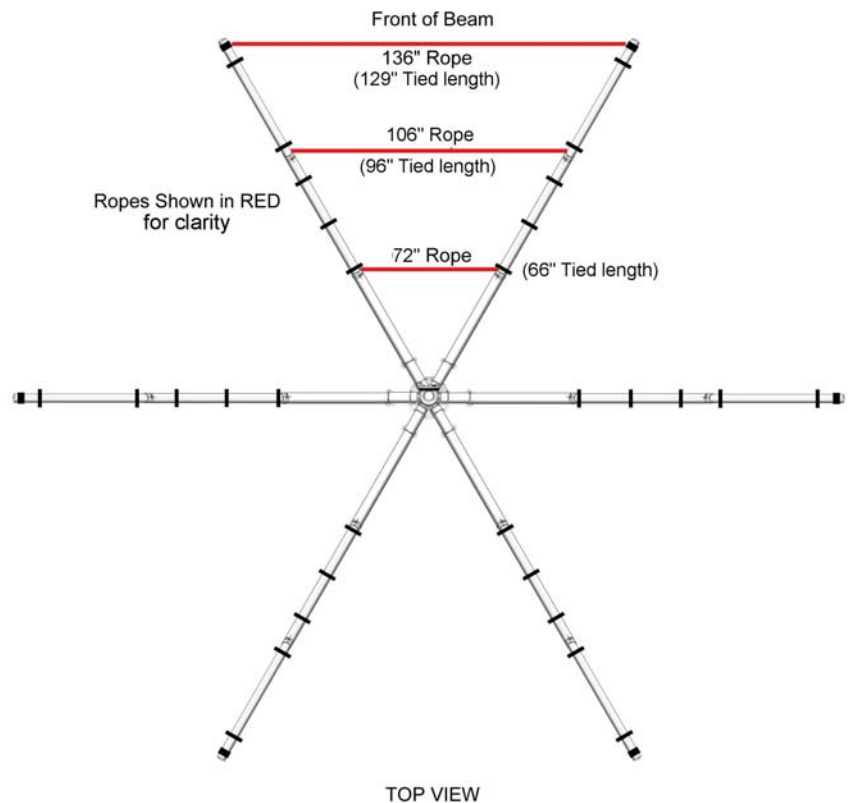
Working with help, if possible, using the step ladder positioned near the center of the antenna. Pull on the spreader support rope to bow the spreader up. The spreader support rope will be horizontal when the spreader is moved into the final antenna position. See **Figure 18**. Knot the rope through one of the three vertically aligned holes on the center post support rope attachment hub. Adjacent spreaders share rope attachment holes on this hub.



**Figure 18**

Repeat this process on the spreader on ‘opposite’ sides of the antenna until all six spreaders are secured in their final position. Each spreader end will be at the same horizontal height position as the rope attachment hub on the center post.

The seventh 136" rope is strung between the spreader rope attachment clamps at the end of the spreaders adjacent to the feeder insulator, across the front of the beam. Secure this rope into a horizontal position without pulling these two spreader ends together as shown in **Figure 19**.



**Figure 19**

Ropes previously installed from the ends of each spreader to the center rope hub are not shown in this picture for clarity.

Install the 72" and the 106" ropes across the front of the beam, tied around the spreaders where the smaller fiberglass spreader section is clamped into the next larger section. Secure these ropes into a horizontal position with out pulling the middle sections of the two spreaders together as shown in **Figure 19**. These two spreaders will now remain straight when the wire elements are strung around and tied and straightened into position with tension.

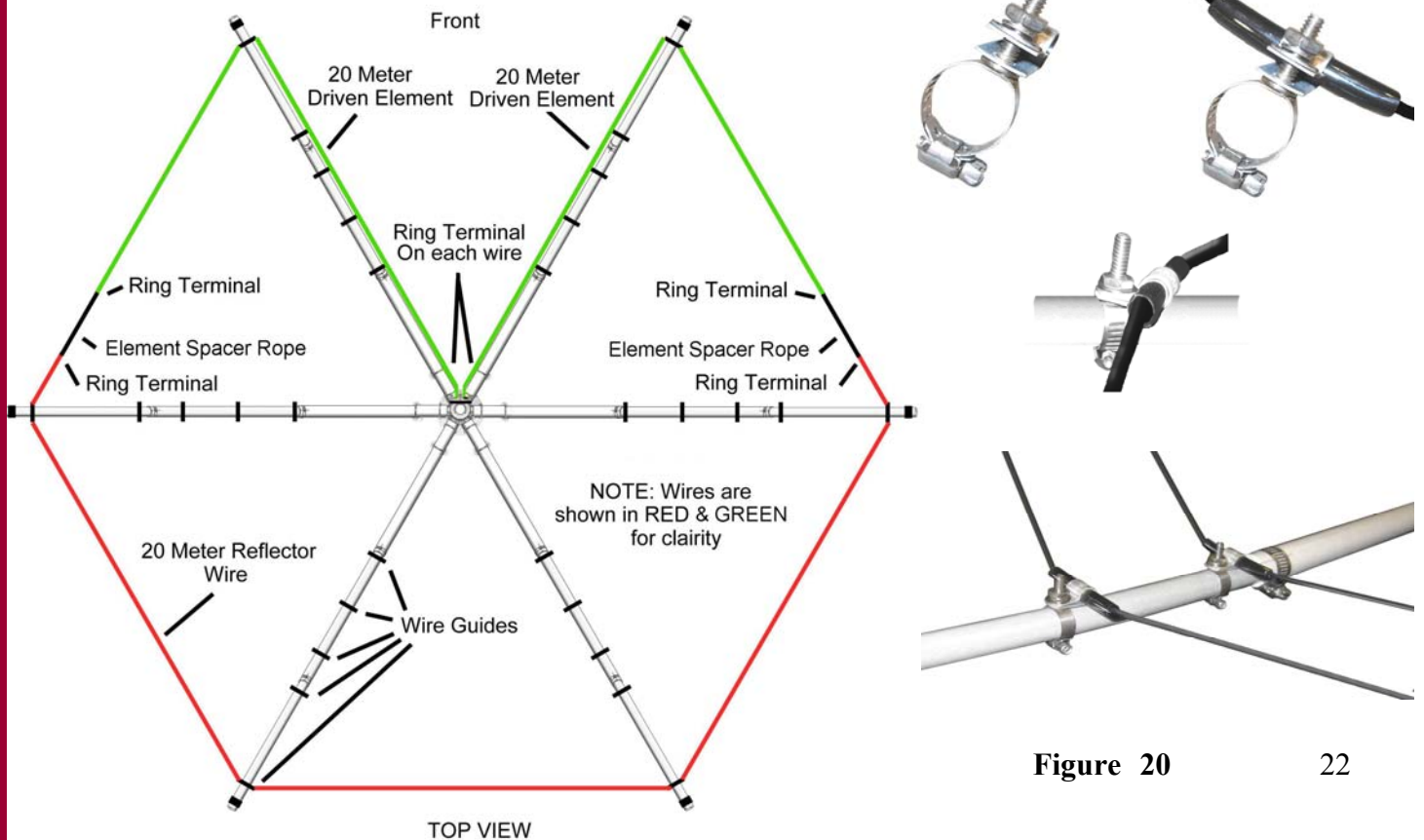
## Installing the Wire Elements

The precut and assembled wire sets have the wire guide tubes and ring terminals installed. The wire lengths are as shown in **Table 2**. Minor variations in these lengths will not adversely affect antenna performance.

Band	Driven Elements (2) Wire Length	Reflector Wire Length
20	17' 10-1/2"	33' 10"
17	13' 10-1/4"	26' 3"
15	11' 10"	22' 6"
12	9' 11-1/2"	19'
10	8' 8-3/4"	16' 8-3/4"

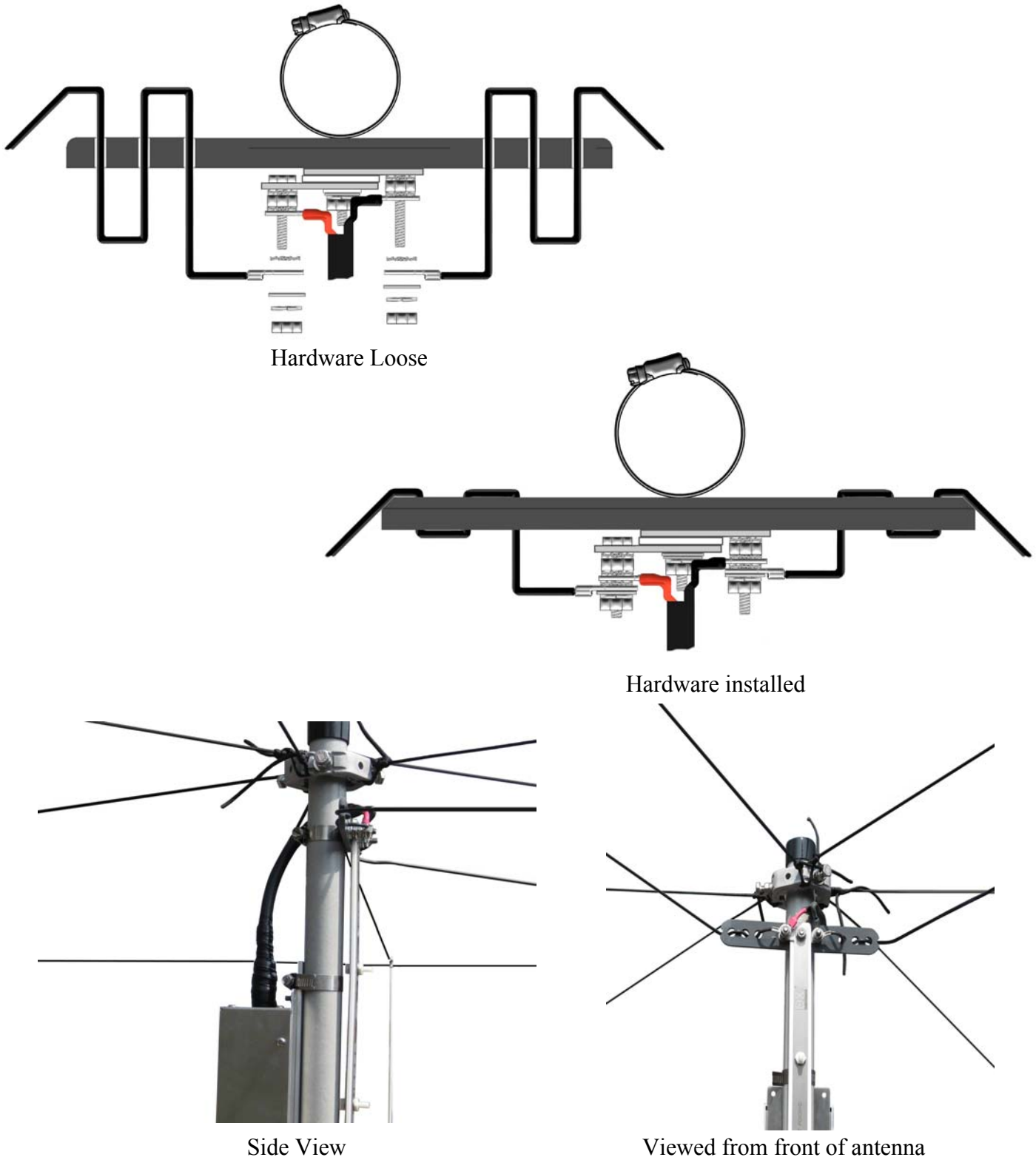
**Table 2 - Driven Wire Elements and Reflector Wire Elements**

Start with the 20 meter band. Thread one end of the two driven element wires (front of beam) with the black tubes and ring terminals through the previously installed wire guide clamps, positioning one of the black tubes through each clamp as shown. The tubes are -pre-installed on the wire sets. Once the tubes are in place, tighten the p-clamp to hold the tubes perpendicular to it's spreader as shown in **Figure 20**.



**Figure 20**

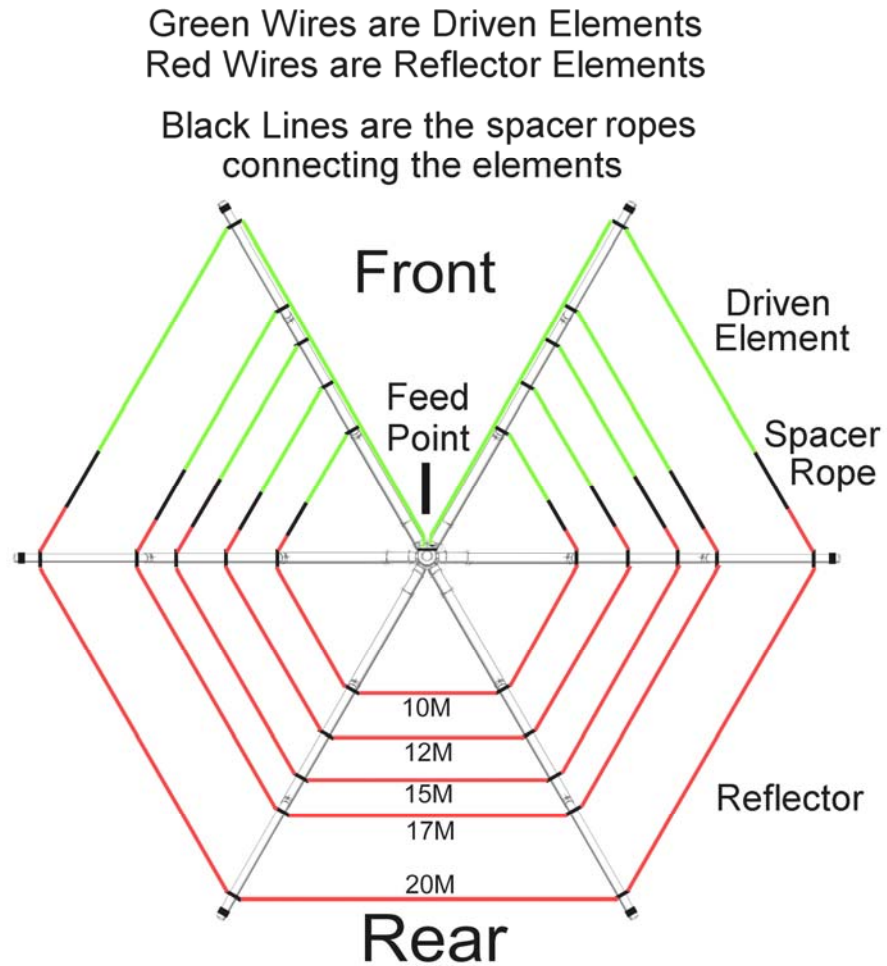
Connect the 20 meter Driven Element Wires to the Five Band Stainless Steel/Teflon® Rigid Feeder. Hardware previously installed to hold the coaxial pigtail is removed and re-used. Refer to **Figure 21** for the hardware sequence.



**Figure 21**

The 20 meter reflector (rear of beam) wire with black tubes and ring terminals is threaded through the p-clamps used for the reflectors in the same manner as the driven element. Thread the wire and black tubes through and position one tube in each p-clamp.

Note: Although not normally required, minor adjustment, or trimming of each wire driven element and/or reflector element wire may be needed to minimize the SWR. Additional Ring Terminals are supplied for this purpose.



**Figure 22**

Repeat the sequence to install the 17 meter driven element wires and the 17 meter reflector wire. The coaxial cable pigtail is only installed on the 20 meter feed.

Repeat the sequence to install the 15 meter driven element wires and the 15 meter reflector wire.

Repeat the sequence to install the 12 meter driven element wires and the 12 meter reflector wire.

Repeat the sequence to install the 10 meter driven element wires and the 10 meter reflector wire.





Figure 23 is a side view for reference showing the wire elements installed.

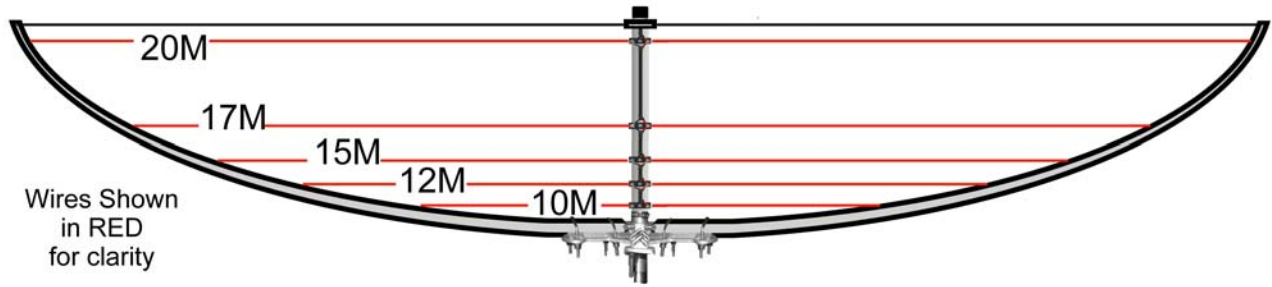


Figure 23

Rope for the element spacers are installed for each band as shown in Figure 24. The cut and final measurements are shown in Table 3.

Band	Element Spacer Ropes Cut Length	Element Spacer Ropes Tied Length
20	30"	23-1/2"
17	24"	18"
15	22"	15-1/2"
12	20"	13-1/4"
10	18"	11-3/4"

Table 3

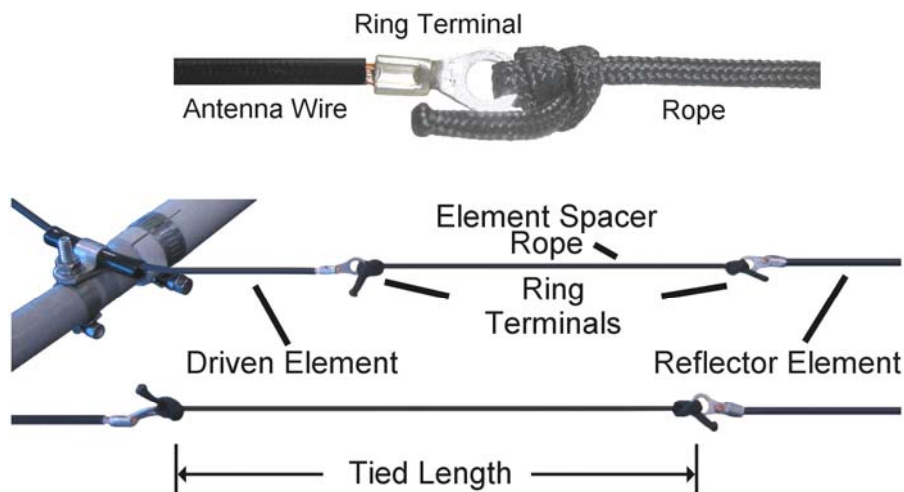


Figure 24

Note: Although not normally required, minor adjustment, or trimming of a particular wire driven element and/or reflector element wire may be needed to minimize the SWR. Additional information on tuning is found in the section: "SWR Testing" at the end of these assembly instructions. Additional Ring Terminals are supplied for this purpose.

Final leveling and slight tension on the wires is accomplished by small, equal adjustments of the wire guide stud clamp positions on the spreaders away from the center of the antenna. Too much tension will distort the shape of the spreaders and slacken the other wire elements. This adjustment process may take some time to get an acceptable balance between element tensions, but the goal is to have all of the wires horizontal, evenly spaced, with only slight tension to prevent antenna wires from moving toward and away from each other in gentle breezes. The unique feature of the “floating wire guides” will allow all of the spreaders and wires to move independently in strong winds without causing undue stress, and then return to their natural position.

Remember, having tight wires will not improve performance - only appearance. A little slack is better than too tight. This will eliminate stretching of the element wires and unnecessary tension on the wire ring terminals.

Perform final tightening of all spreader clamps, wire guide and rope attachment p-clamp hardware and stud clamps. DO NOT over tighten these stainless steel element clamps. A modest tightening of these small gear screws will accomplish sufficient hold.

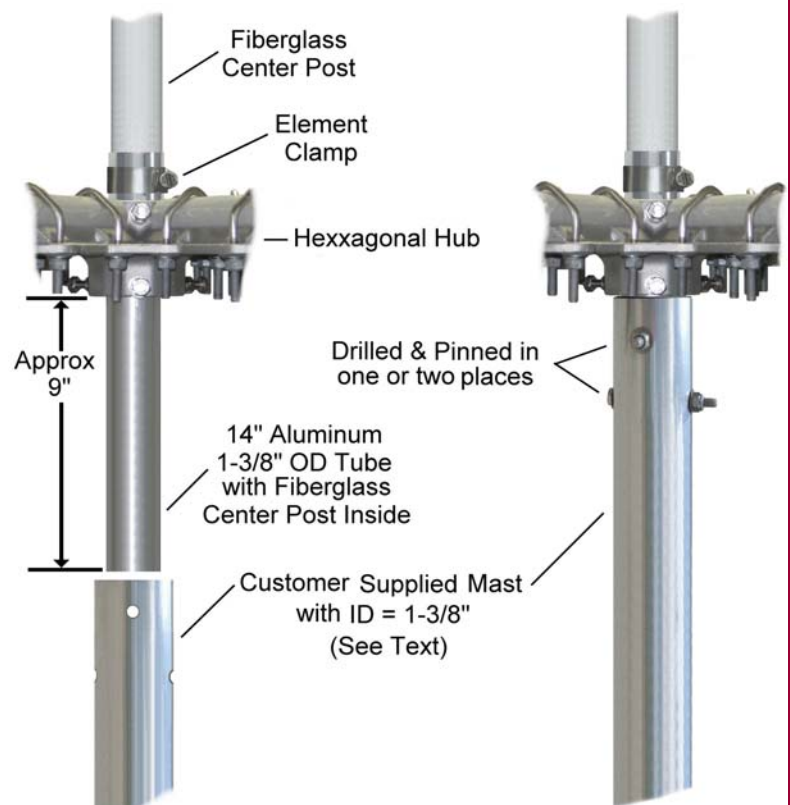
If the optional Feedline Current Choke was not installed, connect a coaxial cable (RG-213 or equivalent) feedline to the included dual female SO-239 (UHF to UHF) adapter installed at the end of the pigtail. If the optional Feedline Current Choke is installed, connect your coaxial cable feedline (RG-213 or equivalent) to the bottom of the Feedline Current Choke. Use electrical tape to hold the coaxial cable to the center post.

## Installation on a Mast and Rotator

The aluminum tube that holds the Fiberglass Center Post is supplied with the Hexxagonal Beam. This tube has an outside diameter of 1-3/8" and may be used directly into a rotator. When mounting the completed Hexxagonal Beam on the customer supplied mast, use mast or tubing that has an inside diameter of 1-3/8".

This mast could be 3 feet or 6 feet long depending on your rotator specifications. When using DX Engineering tubing, use two pieces of .058" wall thickness tubes that are 1-1/2" OD and 1-5/8" OD and nested together to give you a thick wall mast that the 1-3/8" tube will fit in.

Once mounted, the mast should be held to the Hexxagonal Beam tube by drilling one or two holes and pinning as shown in the picture.



Install your completed DX Engineering **HEXXAGONAL BEAM Mark 2** with a rotator at a height of at least 25 feet for very good results. The best overall results are realized with the antenna at 35 to 65 feet.

## SWR Testing

The **HEXXAGONAL BEAM Mark 2** should not require tuning. SWR may be checked when the antenna is at least 8 feet above the ground, however SWR dips may not be under 2:1 or not in the band. Once the antenna is elevated to operating position, SWR curves should dip below 1.5:1 within each band, with much lower SWR likely near the low end or middle of the 20 and 15 meter bands, and lowest SWR around 28.200 MHz in the 10 meter band, however the G3TXQ broadband version provides low SWR over a wide frequency range. If any adjustments are desired, they should be done incrementally and simultaneously with a small changes of driven and reflector element wire lengths. Example: Tuning on 10 meters is done by trimming approximately 1/4" on each driven element wire and approximately 1/2" on the end of the respective reflector wire. Extra Ring Terminals are included in the kit to allow replacements as you trim the wire lengths. Once the frequency of the lowest SWR may appear below the band, if the SWR is checked before the antenna is elevated into appropriate position. Reasonable SWR should be the result on all bands after the antenna is elevated.

Temporary accumulation of moisture or ice on the element spacer ropes has very little effect on SWR.

Enjoy your high quality, DX Engineering **HEXXAGONAL BEAM**, which should offer years of trouble free performance.



\*\*\*\*\*

**Resume assembly from this point if you are building the 1-Band Total Antenna Package - DXE-HEXX-1TAP**

This kit is used to make one band **HEXXAGONAL BEAM** wire elements and attach them to our unique floating element wire guides. The floating wire guides allow your spreaders to have independent movement during windy conditions reducing stress and strain on the element wires and spreaders.

Assembly of the Hexx Hub, Spreaders, Wire Guide Clamps, Rope Clamps and Rope Hub is identical to the Five Band version. The difference being the Single Band has one feedpoint assembly that you will locate on the center post at the desired height for a particular band. The wire element set included is already measured and pre-assembled for 20 meters. If you desire a different band, the wire elements will have to be trimmed accordingly. Extra ring terminals are included in this kit to accomplish that task.

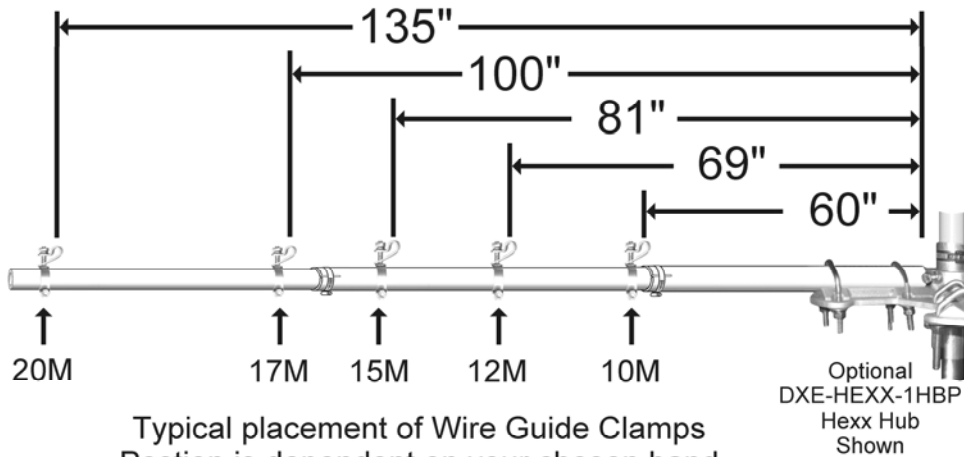
The **HEXXAGONAL BEAM** 1-band Coax Feeder is custom made from high quality coaxial cable. The ring terminals are crimped, hand soldered and special weatherproof adhesive shrink tubing installed for a long lasting precision feedline assembly. The coaxial cable center conductor connection has red shrink tubing on the ring terminal.

Exclusive DX Engineering stainless steel band clamp with welded stud provides a secure attachment for the driven element feedpoints without drilling. The high strength insulator features serpentine wire grip and stainless steel hardware providing superior connections for trouble free operation.

**DXE-HEXX-1WRP-2    HEXXAGONAL BEAM 1-Band Wire Element & Wire Guide**

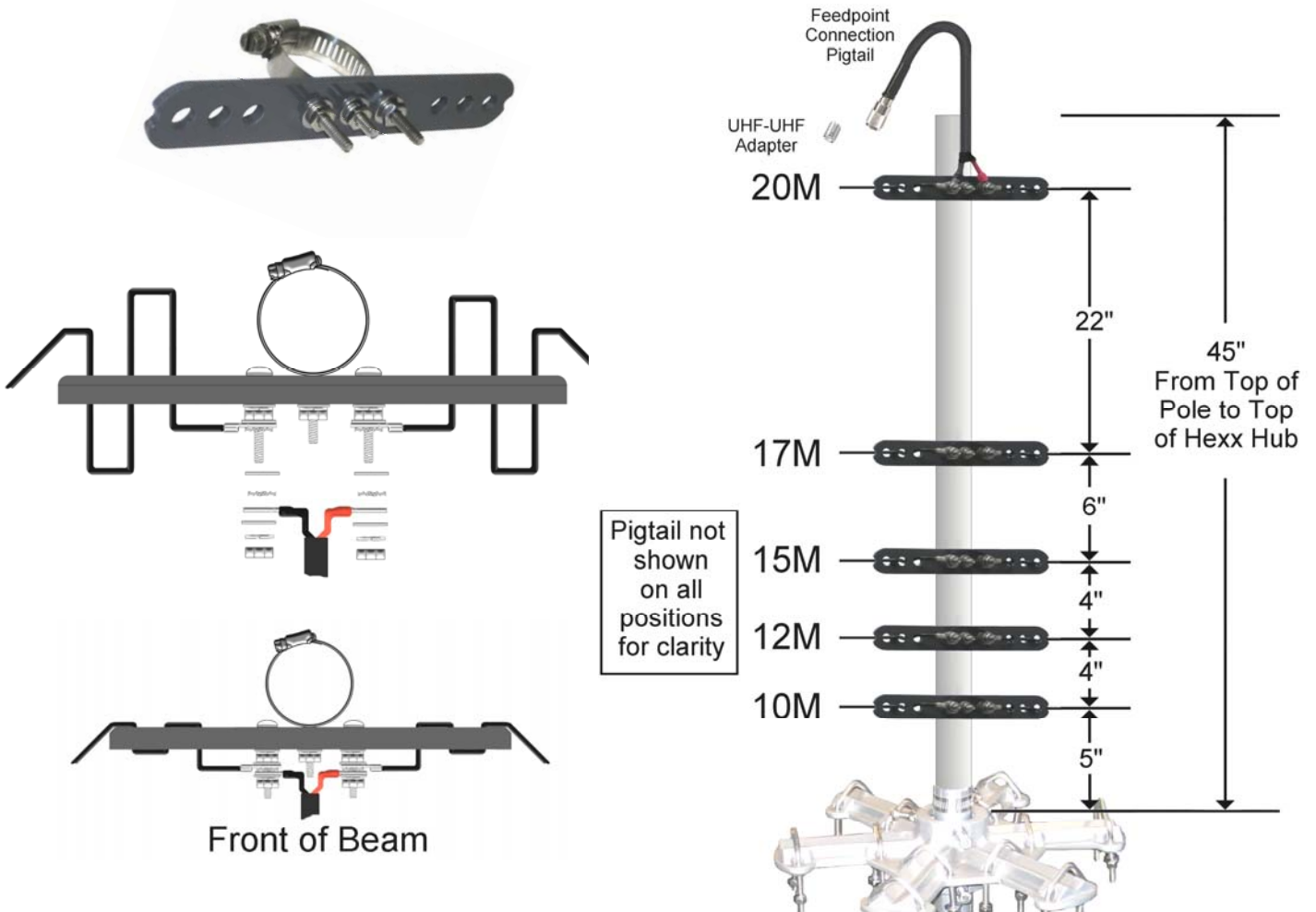
<b>Qty</b>	<b>Description</b>
2	20 Meter Wire Driven Element - #14 Copper Stranded Wire with Black PVC Insulation with Ring Terminals attached and Wire Guides installed
1	20 Meter Wire Reflector Element - #14 Copper Stranded Wire with Black PVC Insulation with Ring Terminals attached and Wire Guides installed
6	#10 hole, 16-14 Wire Gauge Ring Terminal (Spares for various bands and/or adjustment in element lengths)
1	UHF Female-to-Female Adapter (dual SO-239 style)
1	Coax Wire Assembly, 10" with PL-259 and Ring Terminals
1	Single Band Feeder Insulator Clamp Assembly
60"	Double-braided Dacron/Polyester rope
6	Floating Wire Guides for 3/4" Spreader.

Choose the band you are constructing and install the Wire Guide as shown below on a typical spreader positioned vertically. These assemblies may be moved for final positioning on your antenna. Snug them in place and do not tighten.



**5-Band positions - Choose one**

Mount the Single Band Insulator Center Feed Clamp Assembly on the vertical post in the position for the chosen band. One end of the two Driven Element Wires is threaded through the wire guide clamps and connected to the center feed. Route the wires through the center insulator in a serpentine manner as shown.



Thread the other end of the two Driven Element Wires (front of beam) with the black tubes and ring terminals through the previously installed Wire Guide Clamps, positioning one of the Black Tubes through the clamp as shown. Once the tubes are in place, tighten the clamp to hold the tubes.



Depending on the band you are installing, the reflector and the driven elements may be a different length than the supplied set of elements which are cut for 20 meters and have the black tubes and ring terminals installed.

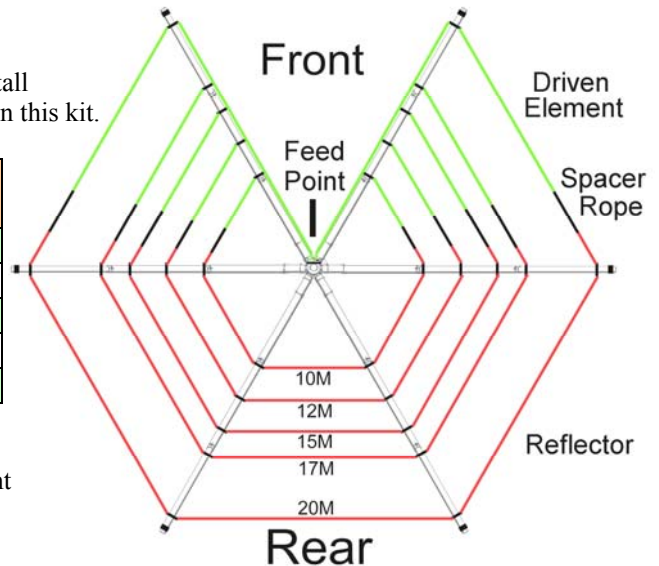
For the other bands, you will have to trim the lengths and install new ring terminal. There are 6 spare ring terminals included in this kit.

Band	Driven Elements (2) Wire Length	Reflector Wire Length
20	17' 10-1/2"	33' 10"
17	13' 10-1/4"	26' 3"
15	11' 10"	22' 6"
12	9' 11-1/2"	19'
10	8' 8-3/4"	16' 8-3/4"

Note: Although not normally required, minor adjustment, or trimming of each wire driven element and/or reflector element wire may be needed to minimize the SWR. Additional Ring Terminals are supplied for this purpose.

Green Wires are Driven Elements  
Red Wires are Reflector Elements

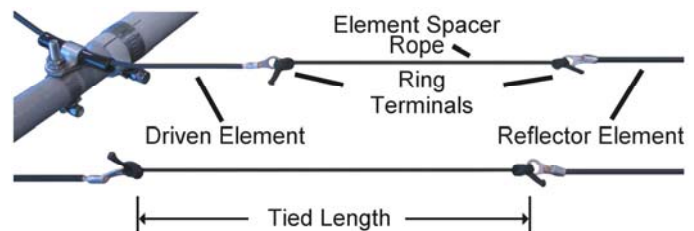
Black Lines are the spacer ropes connecting the elements



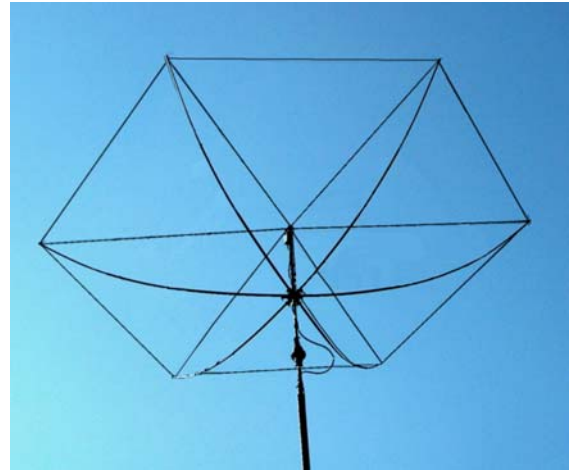
The reflector (rear of beam) wires with black tubes and ring terminals are threaded through the clamps used for the reflector in the same manner as the driven elements. Thread the wires & black tubes through and position one tube in each clamp. Later, once all wire elements are in place you will tighten the clamps that hold the wire guides in place.

Using the 60" of rope included, cut two pieces to the length required for the band you are building. Use the rope to make and connect the elements together for the band you have chosen as shown

Band	Element Spacer Ropes Cut Length	Element Spacer Ropes Tied Length
20	30"	23-1/2"
17	24"	18"
15	22"	15-1/2"
12	20"	13-1/4"
10	18"	11-3/4"



**NOTE:** Creating a 2-band antenna by adding a 1-Band Kit to a 1-band **HEXXAGONAL BEAM** may require special length jumpers and special element dimensions which may vary from the dimensions in this manual. The process of creating a two-band antenna has not been evaluated by DX Engineering. The owner of the antenna assumes the responsibility to make the element and coax jumper lengths required for a 2 band model.



# HEXXAGONAL



# BEAM

## Optional Items

The DX Engineering **HEXXAGONAL BEAM Kits** and **Total Antenna Packages** are ideal for either an experimenter or an operator. They do not require advanced skills to assemble, but they offer plenty of options for making your own design.



**DXE-HEXX-5TAP-2** - The DX Engineering **HEXX BEAM Mark 2 - Five-Band Total Antenna Package** consists of these four kits:

- DXE-HEXX-1HBP**    **HEXXAGONAL BEAM** Hub package (*US Patent No. D605,184*)
- DXE-HEXX-1SCP-2**    **HEXXAGONAL BEAM** Spreader & Center Post package
- DXE-HEXX-5FFP**    **HEXXAGONAL BEAM** 5-Band Stainless Steel/Teflon® Rigid Feeder System  
*Patent Pending*
- DXE-HEXX-5WRP-2**    **HEXXAGONAL BEAM** 5-band Wire Element & Wire Guide package

**DXE-HEXX-1TAP-2** - The DX Engineering **HEXX BEAM 1-Band Total Antenna Package** consists of these three kits:

- DXE-HEXX-1HBP**    **HEXXAGONAL BEAM** Hub package (US Patent No. D605,184)
- DXE-HEXX-1SCP-2**    **HEXXAGONAL BEAM** Spreader & Center Post package
- DXE-HEXX-1WRP-2**    **HEXXAGONAL BEAM** 1-band Wire Element & Wire Guide package

### **DXE-FCC050-H05-A - Feedline Current Choke, 2 kW, for Coaxially Fed 50 Ω Antennas - Aluminum Enclosure**

The DXE-FCC050-H05-A Feedline Current Choke, using Maxi-Core® technology, prevents unwanted RFI by eliminating feedline current and radiation in 50 Ω, coaxially fed antenna systems. It provides excellent feedline decoupling and low loss performance from 1 to 60 MHz and is power rated for 2 kW continuous, 5 kW intermittent. The FCC has significantly higher common mode impedance and a larger effective core area than similar line isolators, including conventional enameled wire or bead baluns.

This results in:

- Higher power handling with lower loss – more power to the antenna
- Improved antenna bandwidth – easier on the radio
- Reduced RFI – less interference to and from your radio
- Compensation for a less than optimal ground system

While most common advice is to improve the station's RF ground, the root of the problem is in the poor isolation of the feedline from antenna currents. In other cases, as the coax feedline travels through the near-field of the antenna, the current can be re-introduced to the feedline after the balun. If your SWR is already low and you wish to reduce feedline radiation (RFI) and improve reception, an FCC is recommended. The **DXE-FCC050-H05-A** Feedline Current Choke is designed for use with coaxially fed, 50 Ω antennas of many varieties including verticals with elevated radials. It is rated at 2 kW.



### **DXE-BMB-1P - Balun Mounting Kit for a .750 in. thru 1.50 in. Boom**

This handy Aluminum mounting bar and Stainless Steel hardware kit will allow you to mount your quality DX Engineering Balun, Feed Line Current Choke, or Vertical Feedline Current Choke, directly to a .750 in. thru 1.50 in. boom or pipe.

Kits includes:

- (1) Mounting Bracket
- (1) Bracket Hardware Kit
- (2) Boom Clamps
- Bar Material: Aluminum
- Bar Hardware and Element Clamp Material: Stainless Steel
- Bar Dimensions: 10 x 1.00 x .125 (inches)





**DXE-81343, NSBT8 - Anti-Seize & Never-Seez**

An Anti-seize compound MUST be used on any Stainless Steel nuts, bolts, clamps or other hardware to prevent galling and thread seizure. Any of these products can be used for this purpose.

*DXE-81343	Anti-Seize, 1 oz. Squeeze Tube
*DXE-81464	Anti-Seize, 8.5 oz. Aerosol Can
*DXE-NSBT8	Never-Seez, 8 oz. Brush Top
*DXE-NMBT8	Never-Seez, 8 oz. Brush Top, Marine Grade

\* These products are limited to domestic UPS Ground shipping only



**DXE-3M2155 - 3M Temflex™ 2155 Rubber Splicing Tape.**

Conformable self-fusing rubber electrical insulating tape. It is designed for low voltage electrical insulating and moisture sealing applications. For outdoor use, it should be protected from UV deterioration with an overwrap of **DXE-33PLUS**



**DXE-33PLUS - Scotch® Super 33+.**

Highly conformable super stretchy tape for all weather applications. This tape provides flexibility and easy handling for all around performance. It also combines PVC backing with excellent electrical insulating properties to provide primary electrical insulation for splices up to 600V and protective jacketing.



**MFJ HF/VHF Antenna/SWR/RF Analyzer w/ LCD, Counter & Meters - MFJ-259B**

The MFJ-259B RF analyzer is a compact battery powered RF impedance analyzer. This unit combines four basic circuits; a 1.8-170 MHz variable frequency oscillator, a frequency counter, a 50 ohm RF bridge, and an eight-bit micro-controller. This unit makes a wide variety of useful antenna or impedance measurements, including coaxial cable loss and distance to an open or short. Primarily designed for analyzing 50 ohm antenna and transmission line systems, the MFJ-259B also measures RF impedances between a few ohms and several hundred ohms. It also functions as a signal source and frequency counter. The frequency range of impedance measurement is 1.8 to 170 MHz, in six overlapping bands. Requires 10 AA size batteries for portable operation (not furnished). See "Suggested Parts" above for AC adapter and accessories.



**RG-8/U Foam Coax Assemblies**

These DX Engineering cable assemblies use high quality Belden 8214/RG-8/U Foam dielectric coaxial cable and include Silver Teflon PL-259 (UHF) connectors installed at each end. RG-8/U cable is protected by a PVC jacket and is normally recommended for indoor applications - or protected areas where ultraviolet contamination is unlikely to occur. When comparison shopping, note that RG-8/U is no longer a government MIL-spec cable - leaving it open to interpretation by many manufacturers. When in doubt, use RG-213/U with a non-contaminating PVC jacket for longest life in most outdoor applications. The coax has a flexible 11 gauge stranded copper center, foamed Poly dielectric, 97% coverage bare copper shield and a black PVC jacket. The PL-259 connector is silver plated with a silver plated center conductor. Connectors are soldered rather than crimped and an adhesive lined shrink tubing is used to form a weather-resistant bond between the connector body and the coax. Each assembly is then 100% Hi-Pot tested to guarantee a quality cable assembly you can count on.



**Custom Lengths Available, Call DX Engineering for Details**

Part #	Part Name
DXE-CBC-008U002	Coax Cable, RG-8/U, UHF connectors, 2 feet for BTV DCF kit
DXE-CBC-008U003	Coax Cable, RG-8/U, UHF connectors, 3 feet
DXE-CBC-008U006	Coax Cable, RG-8/U, UHF connectors, 6 feet
DXE-CBC-008U012	Coax Cable, RG-8/U, UHF connectors, 12 feet

**RG-213/U Coax Assemblies**

These DX Engineering cable assemblies use high quality Belden 8267/RG-213/U coaxial cable and include Silver/Teflon PL-259 (UHF) or male N connectors installed at each end. RG-213/U cable is protected by a non-contaminating PVC jacket and is normally recommended for both indoor and outdoor applications. The UV stabilized jacket assures long life where ultraviolet contamination is a concern. Covered by a government MIL-spec (MIL-C-17, M17/163-00001), you can always be sure of getting the highest quality cable. The coax has a flexible 13 gauge stranded copper center, Poly dielectric, 96% coverage bare copper shield and a non –contaminating PVC jacket. The PL-259 connector is Silver/Teflon with a silver plated center conductor. The N connector is Silver/Teflon with a gold center conductor. Connectors are soldered rather than crimped and an adhesive lined shrink tubing is used to form a weather-resistant bond between the connector body and the coax. Each assembly is then 100% Hi-Pot tested to guarantee a quality cable assembly you can count on.



**Custom Lengths Available, Call DX Engineering for Details**

Part #	Part Name
DXE-CBC-213U3	Coax Cable Assembly, RG-213/U Coax, with PL-259 Connectors, 3ft.
DXE-CBC-213U6	Coax Cable Assembly, RG-213/U Coax, PL-259 Connectors at each end, 6ft.
DXE-CBC-213U12	Coax Cable Assembly, RG-213/U Coax, with PL-259 Connectors, 12ft.
DXE-CBC-213U25	Coax Assembly, RG-213/U Coax, WITH PL-259 Connectors, 25ft.

**50 Ohm Coax Cable Prep Tools**

The UT-8213 simplifies the preparation of RG-8 or RG-213 coax to accept PL-259 UHF style or 2-piece Type N connectors. The UT-808X is specifically designed for stripping RG-8X/Belden 9258 cable. The CNL-911 cutters have specially designed blades to cut the cable without crushing it - leaving the end cleanly cut and ready for stripping and connector assembly. The UT-80P or UT-80N allow mechanical assembly of the PL-259 or 2-piece Type N connector body to the cable without shredding it with pliers. All DX Engineering Cable Prep Tools are designed and selected to provide better results, with greater ease of use.



Part #	Part Name
DXE-UT-8213	Coax Cable Stripper for RG-213, RG-8, 9913F7, LMR-400 etc.
DXE-UT-808X	Coax Cable Stripper for RG-8X, Belden 9258, LMR-240
DXE-UT-RB-HD	Premium Replacement Blades for DX Engineering and Cablematic Strippers
DXE-UT-80P	Connector Assembly Tool for PL-259/RG-213-size Cable
DXE-CNL-911	Coax Cable Cutter
DXE-170M	Precision Shear Side Cutters

**Notes:**

## Technical Support

If you have questions about this product, or if you experience difficulties during the installation, contact DX Engineering at (330) 572-3200. You can also e-mail us at:

DXEngineering@DXEngineering.com

For best service, please take a few minutes to review this manual before you call.

## Warranty

All products manufactured by DX Engineering are warranted to be free from defects in material and workmanship for a period of one (1) year from date of shipment. DX Engineering's sole obligation under these warranties shall be to issue credit, repair or replace any item or part thereof which is proved to be other than as warranted; no allowance shall be made for any labor charges of Buyer for replacement of parts, adjustment or repairs, or any other work, unless such charges are authorized in advance by DX Engineering. If DX Engineering's products are claimed to be defective in material or workmanship, DX Engineering shall, upon prompt notice thereof, issue shipping instructions for return to DX Engineering (transportation-charges prepaid by Buyer). Every such claim for breach of these warranties shall be deemed to be waived by Buyer unless made in writing. The above warranties shall not extend to any products or parts thereof which have been subjected to any misuse or neglect, damaged by accident, rendered defective by reason of improper installation, damaged from severe weather including floods, or abnormal environmental conditions such as prolonged exposure to corrosives or power surges, or by the performance of repairs or alterations outside of our plant, and shall not apply to any goods or parts thereof furnished by Buyer or acquired from others at Buyer's specifications. In addition, DX Engineering's warranties do not extend to other equipment and parts manufactured by others except to the extent of the original manufacturer's warranty to DX Engineering. The obligations under the foregoing warranties are limited to the precise terms thereof. These warranties provide exclusive remedies, expressly in lieu of all other remedies including claims for special or consequential damages. SELLER NEITHER MAKES NOR ASSUMES ANY OTHER WARRANTY WHATSOEVER, WHETHER EXPRESS, STATUTORY, OR IMPLIED, INCLUDING WARRANTIES OF MERCHANTABILITY AND FITNESS, AND NO PERSON IS AUTHORIZED TO ASSUME FOR DX ENGINEERING ANY OBLIGATION OR LIABILITY NOT STRICTLY IN ACCORDANCE WITH THE FOREGOING.

©DX Engineering 2010

DX Engineering®, DXE®, Hot Rodz™, Maxi-Core™, THUNDERBOLT™, Antenna Designer™, Yagi Mechanical™, and Gorilla Grip™ Stainless Steel Boom Clamps, are trademarks of PDS Electronics, Inc. No license to use or reproduce any of these trademarks or other trademarks is given or implied. All other brands and product names are the trademarks of their respective owners.

Specifications subject to change without notice.