



ASSEMBLY INSTRUCTIONS

for the

HEATH WWV ANTENNA

GCA-1000-51 and 52

LOCATION

Location of the WWV antenna is very important. Surrounding objects such as trees, power lines, other antennas, etc. will interfere with the operation of the antenna. To minimize the effect of surrounding objects, mount the antenna in the clear away from other objects.

WARNING: THIS ANTENNA IS AN ELECTRICAL CONDUCTOR, CONTACT WITH THE AC POWER LINES CAN RESULT IN DEATH, OR SERIOUS INJURY. DO NOT INSTALL THIS ANTENNA WHERE THERE IS ANY POSSIBILITY OF CONTACT WITH OR HIGH VOLTAGE ARC-OVER FROM POWER CABLES OR SERVICE DROPS TO THE BUILDING. THE ANTENNA SUPPORT OR SUPPORTING MAST AND/OR TOWER MUST NOT BE CLOSE TO ANY POWER LINES DURING INSTALLATION, REMOVAL OR IN THE EVENT PART OF THE ANTENNA SYSTEM SHOULD ACCIDENTALLY FALL. CONSULT THE NATIONAL ELECTRICAL CODE FOR FURTHER DETAILS.

PARTS LIST

The WWV antenna is shipped in two cartons, one carton (box) and one round 6 foot long tube. The tube contains the aluminum for the elements and the carton (box) contains the electronics, coax cable and hardware.

Contents:

Tube carton:

- 2 - 4 foot long 1/2 inch diameter aluminum elements.
- 2 - 6 foot long 3/8 inch diameter aluminum elements.

Box carton:

- Instructions and Installation sheet.
- Electronics mounting plate containing coils, matching network and connector.
- 50 feet +/- 6" of coax cable with connectors.
- 2 - "U" bolts, mast mounting hardware.
- 2 - "Mounting" bolts, element mounting hardware
- Washers for mounting hardware.
- Screws for mounting elements.
- Clamps for mounting elements.

ASSEMBLY INSTRUCTIONS

Step 1. Locate the two 1/2" outside diameter aluminum elements. One end of each element has a 3/16" diameter hole, the other end is slotted with saw cuts.

Step 2. Locate the Electronics mounting plate containing coils, matching network and connector and place it on a flat surface with the electronics facing up and the antenna "F" connector facing down. The coils will be towards the top. Place a wedge under the electronics mounting plate to stabilize the mounting surface. A horizontal working area of 9 feet is required.

Step 3. Locate the (2) 1/2" "Mounting" bolts and loosely fasten them into the two holes provided at the edges just above the coils. Insert one of the 1/2" elements, the end with the drilled hole, through the "Mounting" bolt on the left side of the electronics mounting plate and align the element hole with that in the electronics mounting plate.

Step 4. Insert a 3/16" diameter screw from the reverse side of the electronics mounting plate, through the hole and through the hole in the element.

Step 5. Place the solder lug connector, the one from the coil on the left side of the electronics mounting plate, over the 3/16" screw. Install 3/16" nut with fingers. Carefully tighten with a screw driver on the reverse side of the mounting plate. Caution: DO NOT OVER-TIGHTEN.

Step 6. Proceed as in step 3, 4 and 5 with the same instructions for the second 1/2" aluminum element which is placed on the right side of the electronics mounting plate.

Step 7. Next locate the "U" bolt hardware. Insert the first "U" bolt and place the clamp with "V" cuts in the edges onto the "U" bolt with "V" facing towards the semicircle.

Step 8. Insert the threaded ends of the "U" bolt through the top holes in the electronics mounting plate. Place a large washer over each end of the "U" bolt followed by a compression lock washer. Place the nuts onto the "U" bolts but do not tighten.

Step 9. Follow the same instructions for the bottom "U" bolt.

At this time it is a good idea to do the following assembly outside.

Step 10. Place the 1/2" stainless steel clamps at the ends of the elements. Tighten loosely so the clamp will not fall off, but will accept the 3/8" elements.

Step 11. Locate the 3/8" elements. On the 3/8" elements place a pencil mark 14" from one end. This is the end that will be inserted into the 1/2" element.

Step 12. Insert the 3/8" element into the 1/2" element so the pencil mark lines up with the end of the 1/2" element. Tighten the stainless steel clamps. DO NOT OVER-TIGHTEN. Be sure the 3/8" elements will not slide within the 1/2" element.

Step 13. Follow the same instructions for the second 3/8" element.

Step 14. Locate the coaxial cable and install it on the antenna "F" connector on the back of the electronic plate.

DO NOT OVER-TIGHTEN.

Step 15. You are now ready to install the HEATH WWV antenna onto the mast. Slide the top of the mast through the top and bottom "U" bolts so top of the mast lines up with the top of the electronic mounting plate. Tighten nuts on "U" bolts. DO NOT OVER-TIGHTEN.

Follow the Antenna Installations for instructions on how to locate and install your HEATH WWV ANTENNA.

WWV ANTENNA ASSEMBLY

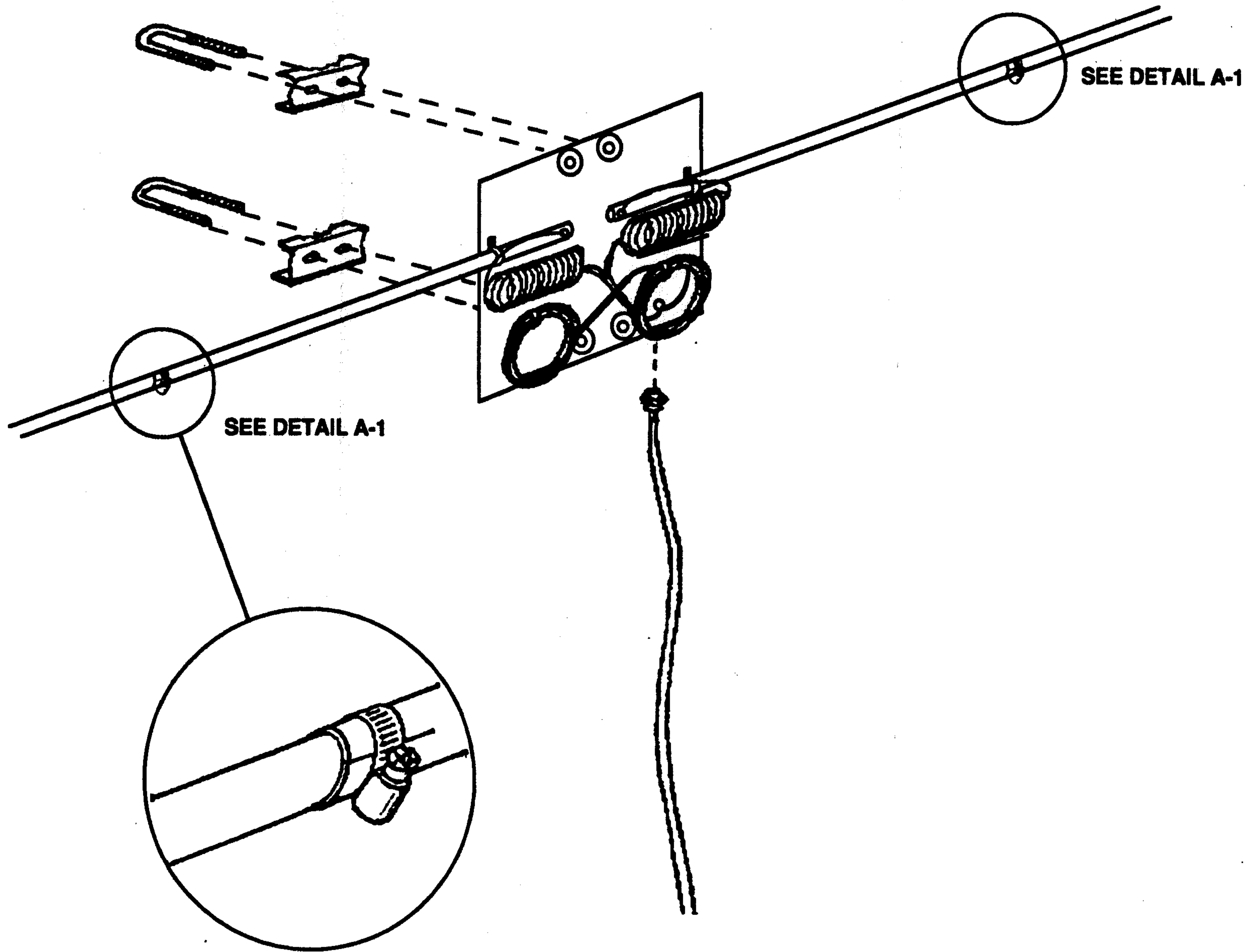

SEE DETAIL A-1

SEE DETAIL A-1

DETAIL A-1

8"

U-BOLT HOLES



2 3/8"

2 3/8"

Coil
55 Turns

Coil
56 Turns

1 inch

1"

7"

a Times Around

21 Times Around

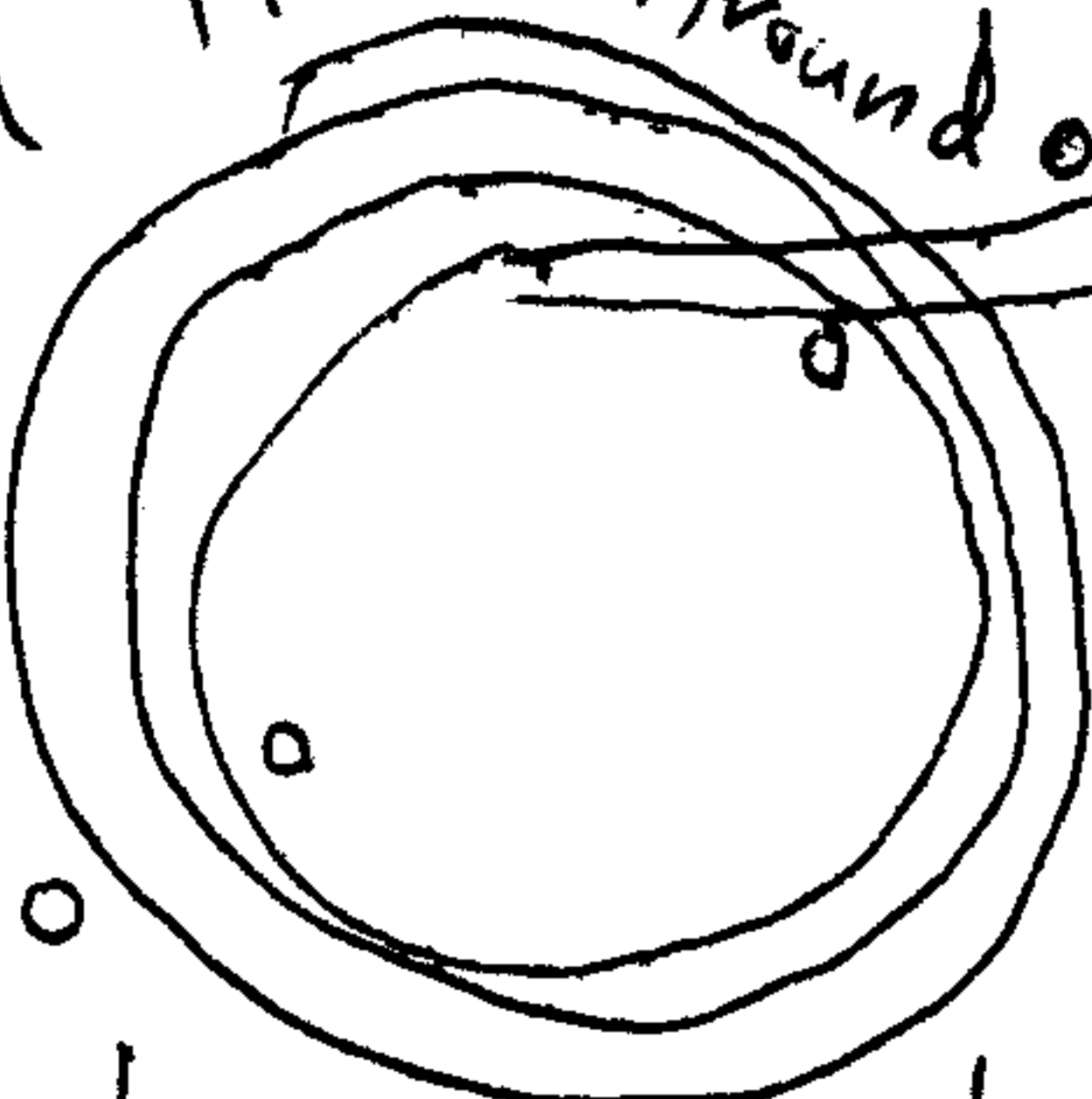

2"

U-BOLT HOLES

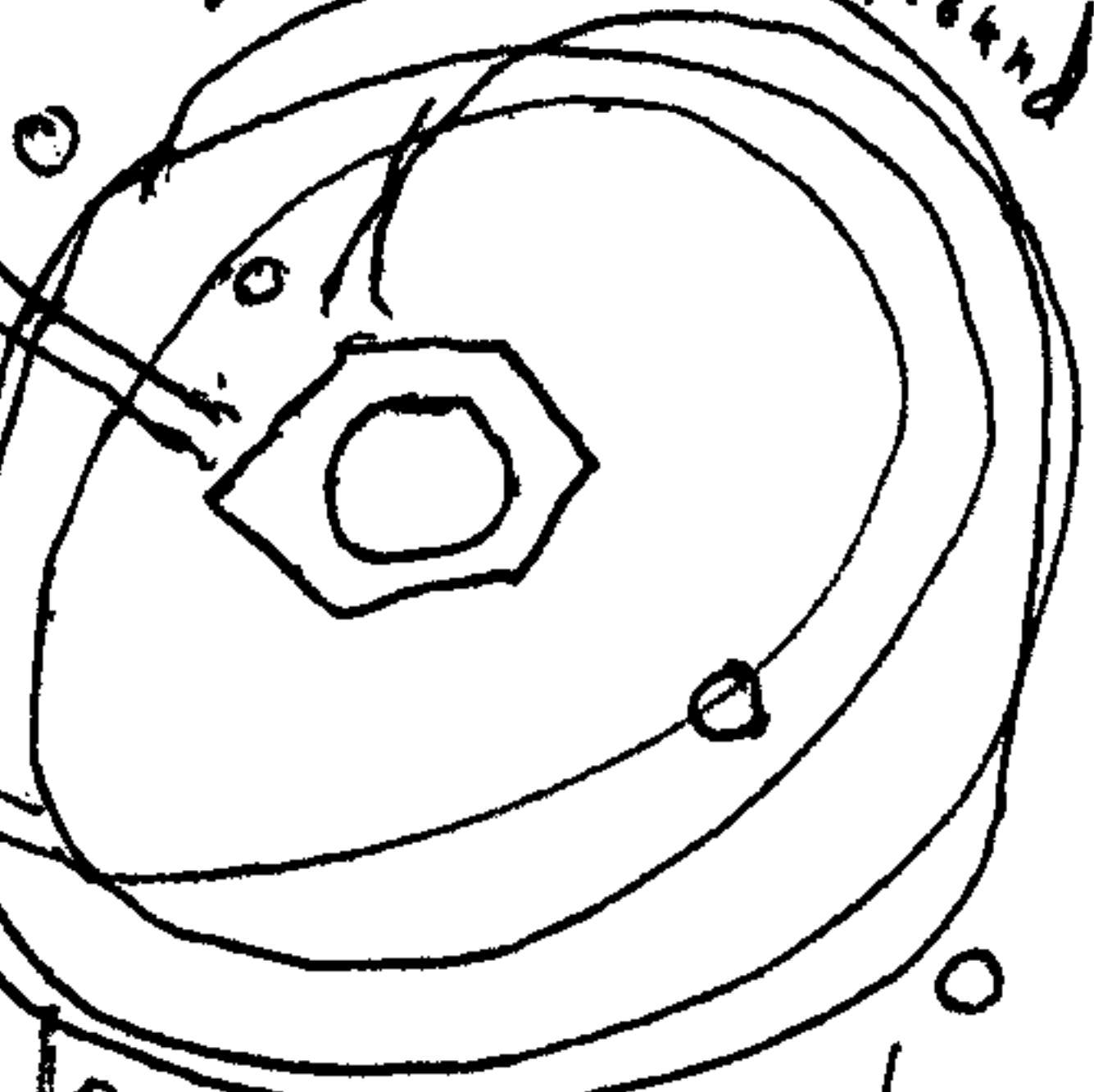

2 1/4"

Congratulations !!! You are now the proud owner of a specifically designed WWV receiving antenna.

This WWV multi-band receiving antenna package contains complete assembly instructions for your antenna. This WWV antenna has been designed to take advantage of maximum transfer of energy (received signal) on the 5, 10 and 15 MHz bands. Remember this antenna is for receive only. Do not try to transmit on these frequencies, which is illegal and great damage will result to the antenna. Please follow these instructions closely.

WARNING

INSTALLATION OF THIS PRODUCT NEAR POWER LINES IS DANGEROUS. FOR YOUR SAFETY, FOLLOW THE ENCLOSED INSTALLATION DIRECTIONS.

HOW TO INSTALL YOUR HEATH WWV ANTENNA SAFELY IN ACCORDANCE WITH THE RECOMMENDATIONS OF THE U.S. CONSUMER PRODUCT SAFETY COMMISSION.

YOU, AND YOUR WWV ANTENNA, AND SAFETY

Each year hundreds of people are killed, mutilated or receive severe permanent injuries when attempting to install an antenna. In many of these cases, the victim was aware of the danger of electrocution, but did not take adequate steps to avoid the hazard.

For your safety, and to help you achieve a good installation, please **READ** and **FOLLOW** the safety precautions below: **THEY MAY SAVE YOUR LIFE!**

1. If you are installing an antenna for the first time, please for your own safety as well as others, seek **PROFESSIONAL ASSISTANCE**. Consult your dealer or the Heath Company. We can explain which mounting method should be used for the WWV antenna.
2. Select your installation site with safety, as well as performance in mind. **REMEMBER: ELECTRIC POWER LINES AND TELEPHONE LINES LOOK ALIKE, FOR YOUR SAFETY, ASSUME THAT ANY OVERHEAD LINES CAN KILL YOU.**
3. Call your electric power company. Tell them your plans and ask them to come to your proposed installation. This is a little inconvenience considering **YOUR LIFE IS AT STAKE**.
4. Plan your installation carefully and completely before you begin. Remember, the mast that the antenna is attached to is also **DANGEROUS AND CAN KILL YOU**. A successful antenna installation is largely a matter of coordination. Each person should be given a specific job, and should know what to do and when to do it. One person should be appointed as the leader of the antenna installation and watch out for signs of trouble.
5. **REMEMBER**. When installing your WWV antenna:
DO NOT USE A METAL LADDER.
DO NOT WORK ON A WINDY DAY.
DO dress properly - shoes with non-slip rubber soles and heels, rubber gloves, long sleeve shirt or jacket. Don't think about the job without these items.
6. If the assembly (antenna and mast) starts to fall, get away from it and let it fall. **REMEMBER: The antenna, mast, cable and metal guy wires are all excellent conductors of electrical current. Even the slightest touch of any of these parts to a power line completes an electrical path through the antenna and the installer – THAT'S YOU**
7. If any part of the antenna system should come in contact with a power line – **DO NOT TOUCH IT OR TRY TO REMOVE IT YOURSELF. CALL YOUR LOCAL POWER COMPANY.** They will remove it safely.

8. If an accident should occur with the power lines —
DON'T grab hold of the person in contact with the antenna and power lines or you too will be electrocuted. Use something DRY like a board. If the victim has stopped breathing, after removing, administer artificial respiration — and stay with it. Have someone call for medical help.

LOCATION OF ANTENNA

Check around your building or home as to where you want to install your antenna, which would be the best location, are you far enough away from all power lines including the service coming into your home and is it convenient to bring the coaxial cable and ground wire into your home the shortest way. The distance from power lines should be twice the height of your antenna and your mast or tower.

There are various methods of installing an antenna including a mast with your antenna on top attached to the side of your building, a tripod with a mast and antenna on top fastened to your roof, a mast on a swivel base attached to your roof over a roof rafter and guyed to the roof, a self supporting tower with your antenna on top and a telescoping mast with guy wires for every ten feet of height. Your chimney will make a good support providing the masonry is solid and a mast can be secured with stainless steel straps and clamps. The height of your antenna does have a bearing on your reception, usually the greater height is better, however, you must compromise with a structurally safe mounting considering the top wind speeds in your area (these may be secured from your closest weather bureau). The FCC limits the height of your antenna to 60 feet maximum. Check your local building codes for restrictions on heights.

ANTENNA CONSTRUCTION METHODS.

When installing an antenna on a roof always check that any fastenings and the antenna load is supported on a roof rafter, the same for any other attachments such as eye bolts for guy wires. Preferably use brass or stainless steel hardware or at least galvanized steel. Always protect any fastenings through the roof with caulking compound or black plastic roofing cement.

ELECTRONIC CONSTRUCTION METHODS

Coaxial cable is used to connect your antenna to your receiver. Your antenna has a coax connector to mate with the coax connector on your coax cable. This is supplied with your WWV antenna. When this connection is made be sure to place a waterproof covering on this connection. It is preferable not to let the coax lay on the roof. When running it down the side of the house fasten it so it cannot swing in the wind. National Electrical Code instructions recommend a static discharge unit be placed in the coax line before it enters the house and, with the proper ground connections. Drill the hole through the wall where the coax is to enter the house. Form a rain drip loop in the coax before entering the house. After the coax is installed caulk both sides of the wall where coax comes through. Run your coax to your receiver. It is suggested that any mast or tower be grounded at its base. One or more eight foot ground rods should be driven into the ground as close as possible to the tower or mast. Connect the tower or mast with a No. 10 copper or a No. 8 aluminum or copper clad steel wire. When the mast is on the roof it will be necessary to use standoff insulators on the roof and down the side of the house so this wire does not touch anything that could start a fire. Caulk all points where standoff insulators are fastened through the roofing. Connect the ground wire to the ground rods with clamps.

CHOOSE A PROPER SUPPORT AND MOUNTING METHOD:

There are many types of supporting structures commonly used in antenna installations. Illustrations of these devices and various mounting methods follow.

MOUNTING YOUR ANTENNA

You have chosen the best location for your antenna and now you must select the type of mount that is necessary for this location.

Drwg. #1 You have selected a side mount fastening. You will have to purchase two brackets deep enough so the mast will pass the eave. If the wall is wood construction you will have to locate the studs, normally 16 inches on center, for fastening the brackets. If the spread of the bottom of the bracket cannot span the

distance between the studs you will have to provide 2" X 4"s bolted to the studs and bolt the bottom section of the brackets to the 2" X 4"s. If the wall is of masonry construction it will be necessary to use expansion anchors of the hard metal type that will take a 5/16" or 3/8" bolt. Do not use expansion anchors made of plastic or lead. Use a carbide tipped drill for drilling the holes in the masonry.

Assemble your antenna on the ground feeding the coax cable through the mast and make all connections to the antenna. Raise the antenna and mast to the brackets and attach the front half of the brackets to hold the mast in place. Any long runs of coax will have to be fastened so it does not swing in the wind. It is well to tape the coax where it enters the mast to stop movement so it cannot be cut by the end of the mast.

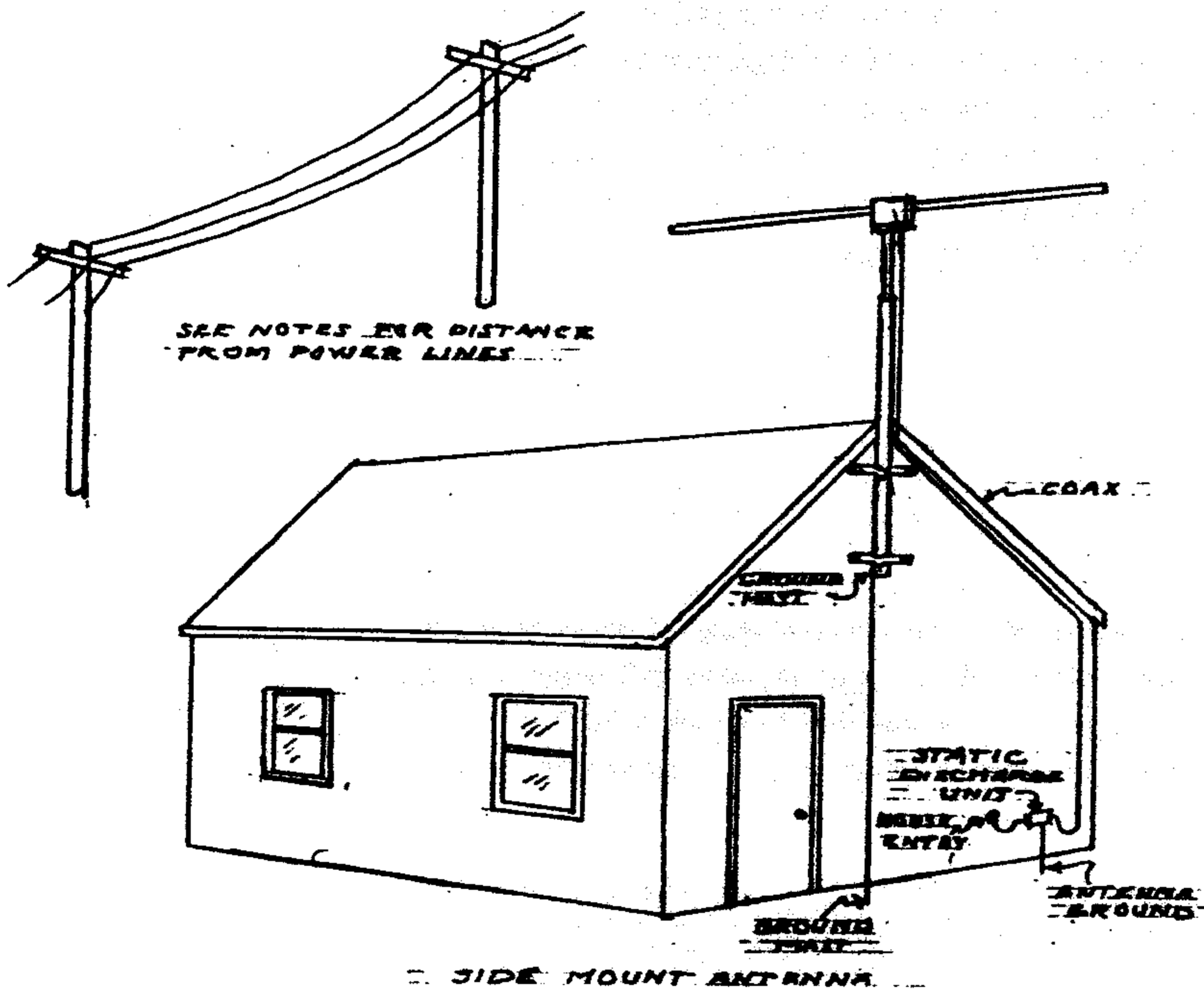

Drwg. #2 This drawing shows a roof mount support. When you purchase this roof mount be sure you purchase a tube of a good caulking compound. Locate the roof rafter exactly and center the holes in the base plate over the rafter. Drill pilot holes through the roofing and partly into the rafter. Remove the base plate and place a bead of caulking on the roof around the holes. Replace the base plate and fasten to the roof rafters with lag bolts and washers, 1/4" to 3/8" in diameter and of a length that will enter the rafters 1-1/2" to 2", this does not include the length necessary to go through the roofing and roof deck material. Install antenna as described in drwg. #1.

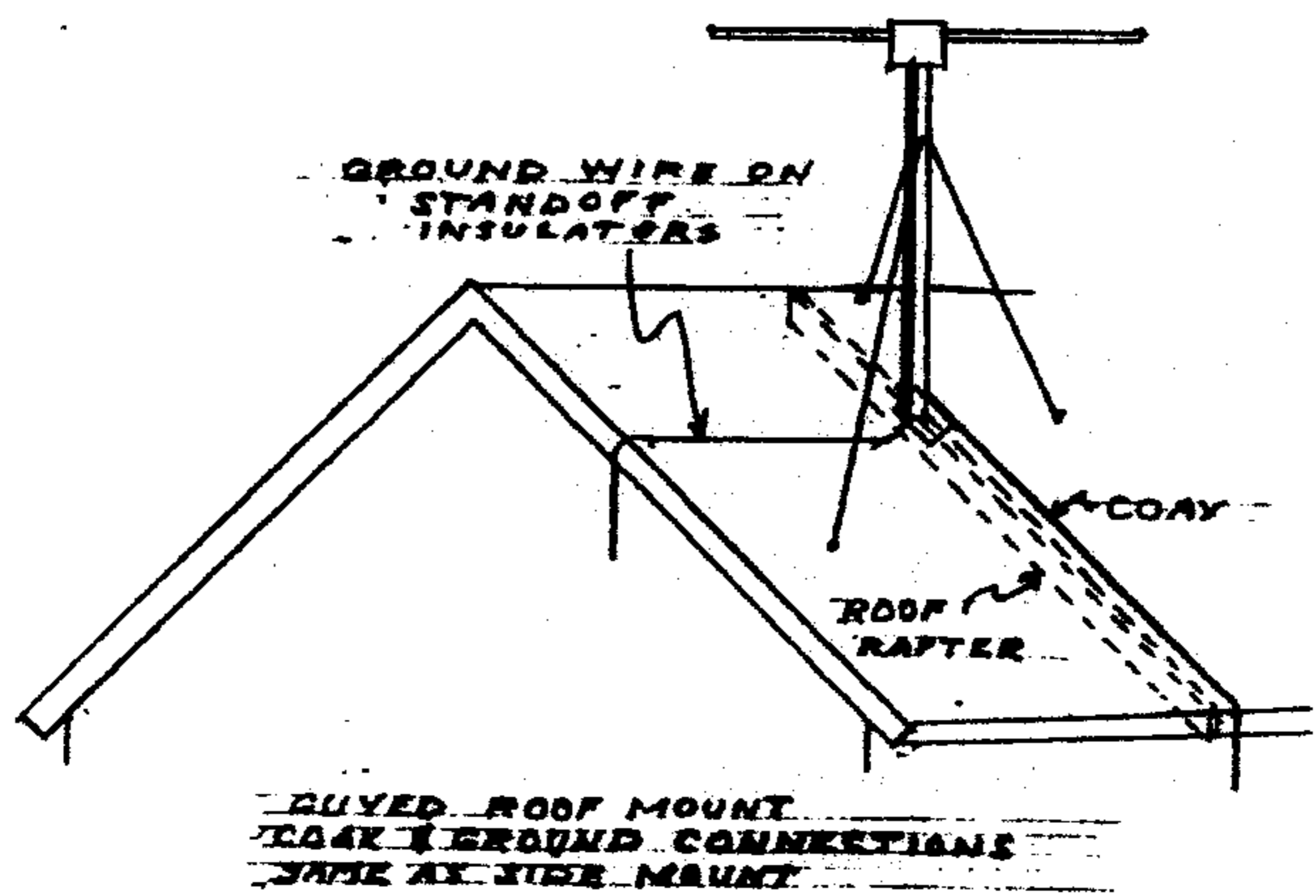

Drwg. #3 This drawing is for a telescoping pipe mast. Provide a concrete pad for support if no other masonry is available. Be sure you get a base plate, preferably, with a tilt over connection to the pipe. Fasten the base plate to the concrete. Establish the location of the guy wire supports, normally three are required 120 degrees apart. Install the supports, either using the screw in type of sufficient holding power or dead heads may be buried in the ground. Extend the pipe mast to its full length on the ground with the large end at the base support and at 90 degrees to a line running from the base support to one of the guy wire supports. You now can measure the length of wire needed for each of the guy wires by the dimension from the guy wire tie on the pipe mast to the guy wire anchor tie. Add sufficient to make ties. Do this for each of the different heights of mast ties. Make all guy wire connections to the mast. Follow instructions for installation of the antenna as given in Drwg. #1. With enough people raise the mast to its permanent location, make sure the mast is perfectly plumb and make final ties of guy wires to the anchors.

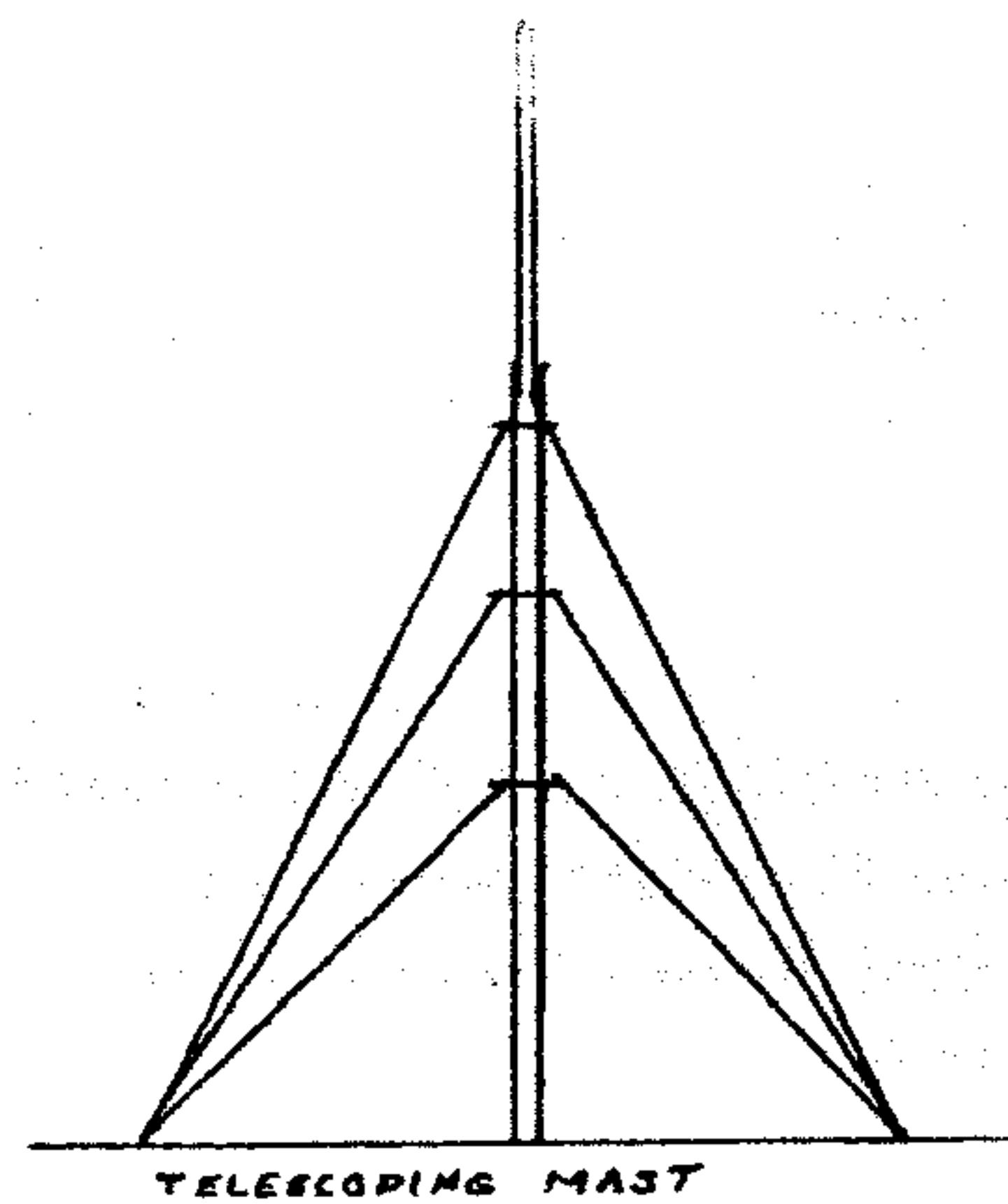

Drwg. 3

Drwg. #4 A standard chimney antenna mount is available at your local TV store and follow directions that come with the mount. You will have to know the length of stainless steel straps that are needed to go around the perimeter of your chimney plus the overlap when you purchase this mount.

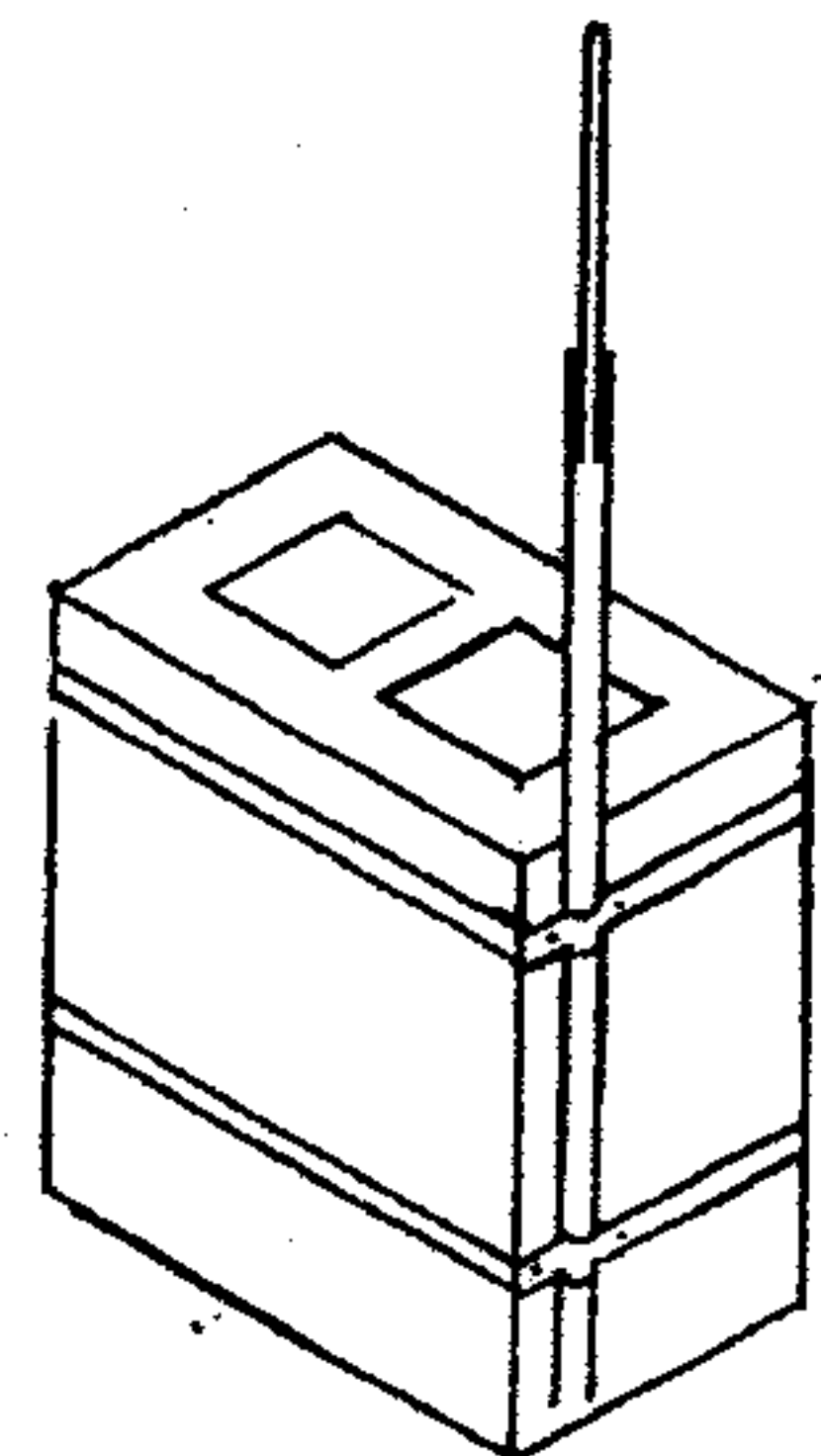

Drwg. 4

Drwg. #5 This is for a self supporting tower. You will have to provide a concrete base for this and the size of the base as well as the installation of the tower will have to be secured from the manufacturer. Follow antenna instructions under Drwg. #1.

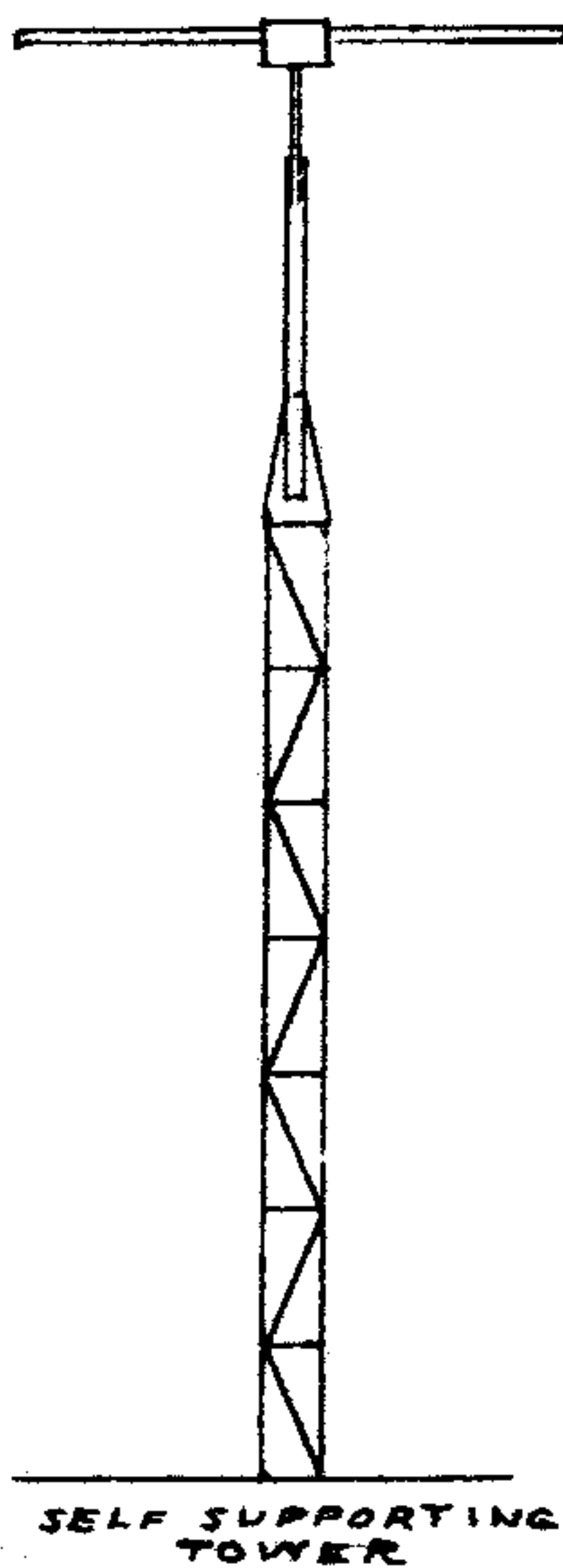

Drwg. #5

Drwg. #6 This is for a tripod support for an antenna. This tripod is usually purchased assembled. You will have to locate the roof rafters for mounting this antenna and in most cases it is necessary to place 2" X 4" bracing in between the roof rafters under the roof to get support for the legs of the tripod support. Line up tripod with the supports below and drill pilot holes through the roof and into supports. Remove tripod and install caulking around each hole. Set tripod back and using 1/4" or 3/8" lag bolts and washers long enough to enter 1-1/2" to 2" into rafters and fasten the tripod. Install the antenna and mast as described under Drwg. #1.

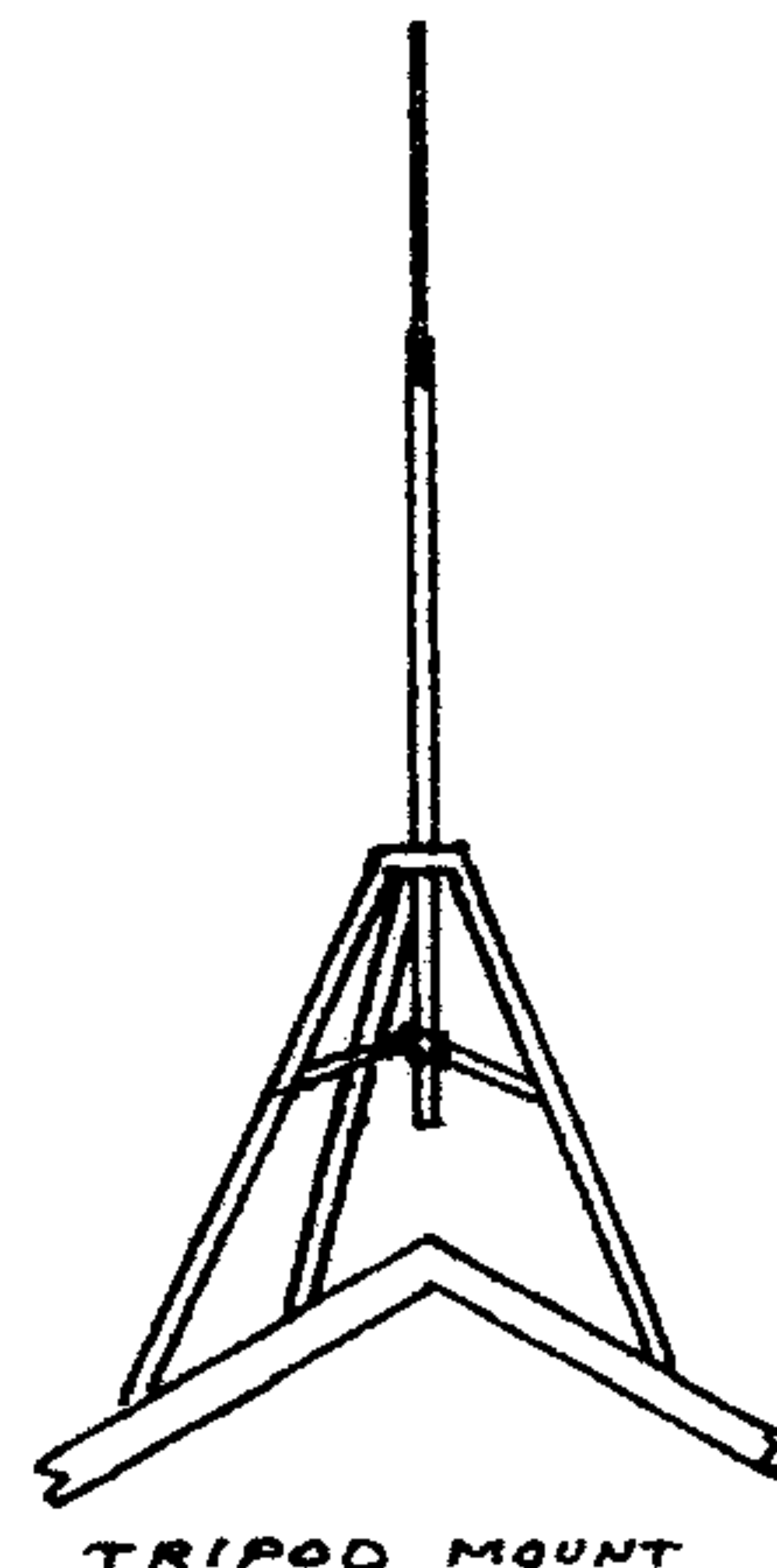

Drwg. 6

NOTE: The above information is a guide for the installation of your antenna. Should you feel unsure about the installation we suggest you get professional help.