

Installation Instructions Hustler 6-BTV Trap Vertical

ASSEMBLY

1. Check the package contents against the parts list on page 2.
2. **WARNING.** Installation of this product near power lines is dangerous. For your safety, read the enclosed warnings and follow the installation directions.
3. Prepare split lead on coax in accordance with figures 2 and 3. RG-8/U coax is recommended. (See decoupling information, page 12).
4. Install lugs on coax as shown in figure 4 and weatherproof with electrical tape.
5. Install coax feedline and radials (if needed) as shown in figure 7. Coax length is not critical.
6. After making all connections it is recommended you spray the bracket assembly with a heavy protective coating such as Krylon clear spray coating.
7. Assemble all 1-1/4 in. stainless steel clamps using the 1/4 in.-20 x 3/4 in. screws and 1/4-20 square nuts.
8. Attach the 10-meter trap to the 72 in. tube using one of the clamp assemblies. Set dimension "A" as indicated in the table in figures 5 and 6.
9. Assemble one of the 20 in. tubes on top of the 10-meter trap using a clamp assembly. Place the 15-meter trap on top of the 20 in. tube and set dimension "B" (see table figures 5 and 6). Repeat this step with another 20 in. tube and install the 20-meter trap. Set dimension "C".
10. Put the 24 in. tube above the 20-meter trap. Place the 30-meter trap on it, using clamp assemblies. Set dimension "D" (figures 5 and 6).
11. There is no trap for 40 meters. The 40-meter section consists of a 36 in. tube with a threaded stud on the upper end. Install the 40-meter tube on the top of the 30-meter trap. Set dimension "E" (figures 5 and 6).
12. Screw on the 75/80-meter resonator at the top of the 40-meter tube and adjust the tip rod in accordance with figure 8.
NOTE: The Hustler RM-75S and RM-80S resonators are the same. Tip rod length is the only difference.
13. Place the antenna on the bracket assembly and set dimension "A", using the last clamp assembly.

PACKAGE CONTENTS

Part Number	Description	Qty.
4087-1	Tube 1-1/4 in. x 72 in.	1
4087-2	Tube 1-1/4 in. x 20	2
4087-11	Tube 1-1/4 in. x 24	1
4090-1	10 Meter Trap Assembly	1
4090-2	15 Meter Trap Assembly	1
4090-3	20 Meter Trap Assembly	1
4090-4	30 Meter Trap Assembly	1
4098-1	Bracket Assembly	1
4104-5	Resonator Body	1
4190-1	Tube and Top Plug Assembly	1
4904-80S	Tip Rod and Marker Assembly	1
6747	Hardware Kit	1

IN PLASTIC BAG

Part Number	Description	Qty.
2223-41	Washer 1/2 in. O.D. x 3/16 in. I.D.	2
2382-32	Hex Nut 1/4 in.-20 x 7/32 in. Thick	4
2491-5	Lock washer 1/4 in. Split	4
3488-6	U-Bolts	2
3152-8	Clamps, Tube SS	9
2382-1	Nut, Hex 10-32 SS	1
4513	Terminal Lug 1/4 in. Hole	1
4514	Terminal Lug #10 Hole	1
6099	Danger Label	1
2233-16	Washer 5/8 in. O.D. x 1/4 in. I.D.	4
2382-32	Hex Nut 1/4-20 x 7/32 in. Thick	2
2491-5	Lock washer _ in. Split	2
2700-7	Hex Head Bolt 1/4-20 x 1-1/2 in.	2
2381-10	Lock washer, Ext. #10 SS	1

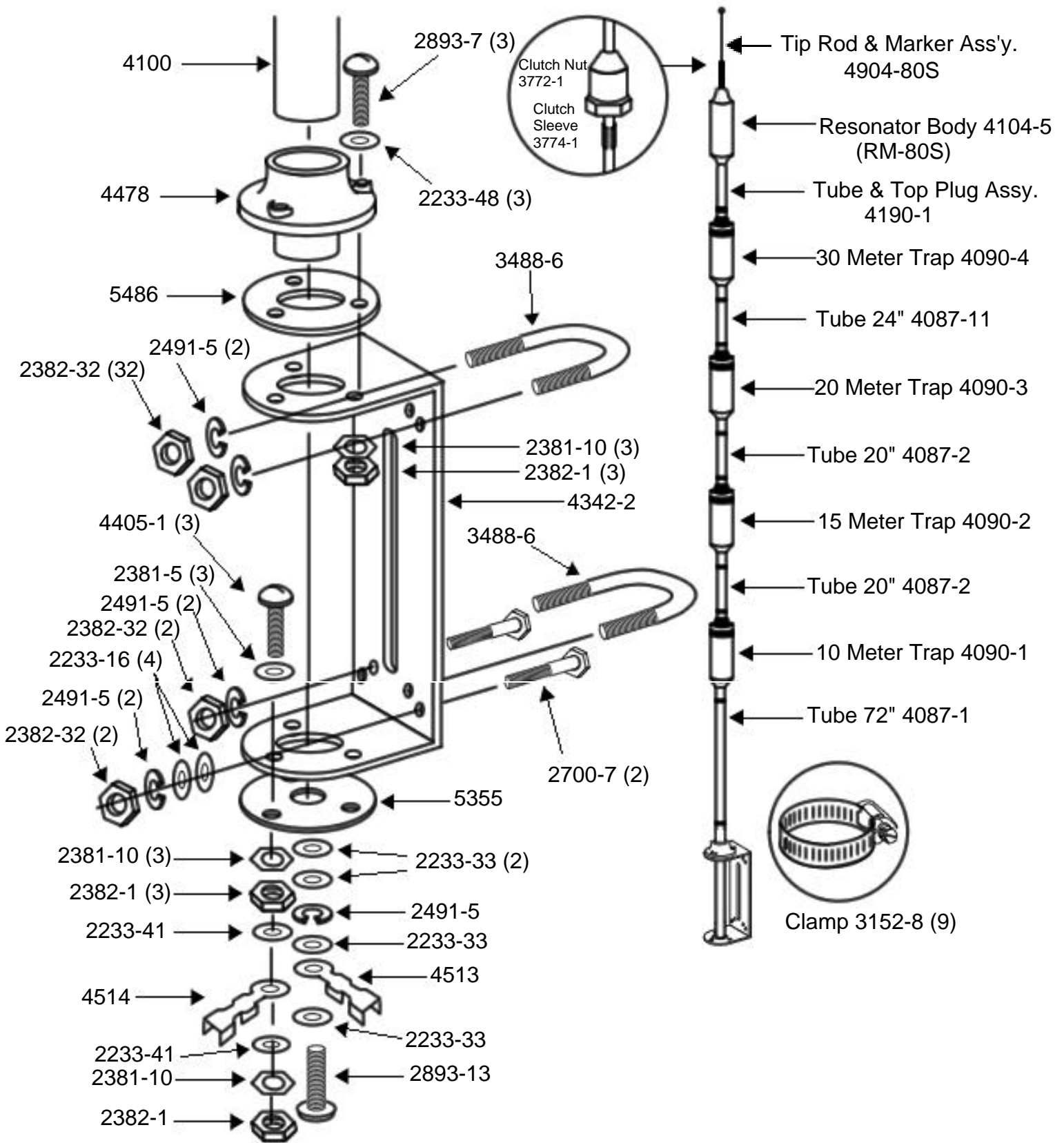

Recommended Method of Preparing Coax

Split End

FIG 2

Separate strands of braid with an awl, being careful not to break any.

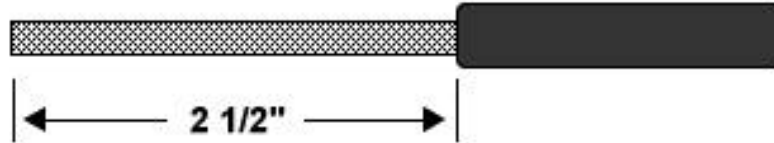

FIG 3

Draw center conductor out with an awl or dull pointed instrument.

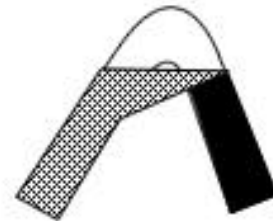
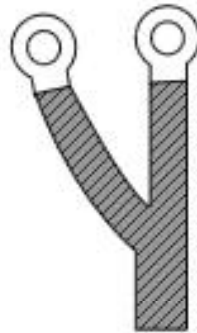

FIG 4

Lug with 3/16" dia. hole on shield end.



Lug with 1/4" dia. hole on hot side.

Solder on the size lugs as indicated above.
Tape tightly with plastic electrical tape.
After installing coat with corona dope.

FIG 5

Dimension Table

Type of installation	A	B	C	D	E
Elevated with radials	2 1/8	2	1 7/8	1 1/2	1
Ground mounted without radials	0	1/2	1 1/16	2	2
Ground mounted with radials	1	1 5/8	1 1/16	1 1/2	1 1/2

Approximate dimensions in inches

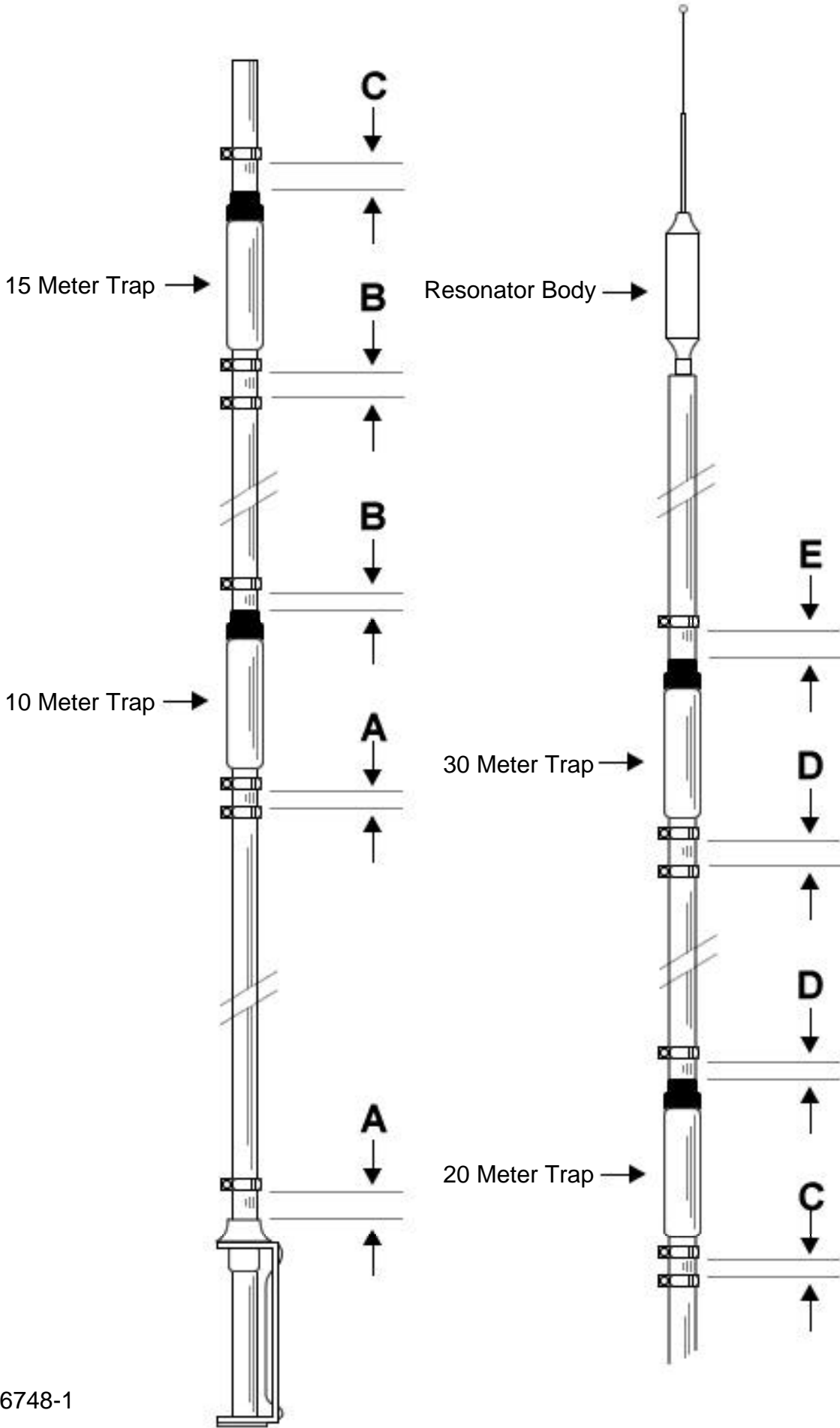

Radials (Not Supplied)

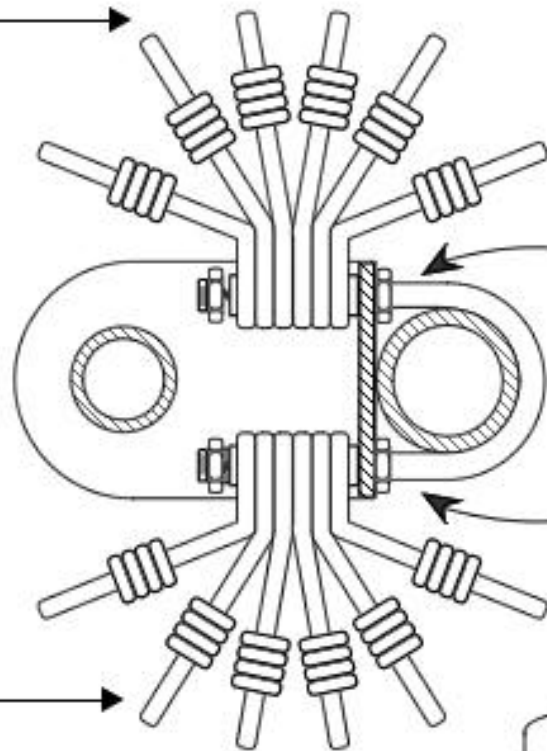

- 2700-7 Bolt (2)
- 2233-16 Washer (4)
- 2491-5 Lockwasher (2)
- 2382-32 Hex Nut (2)

Radials (Not Supplied)

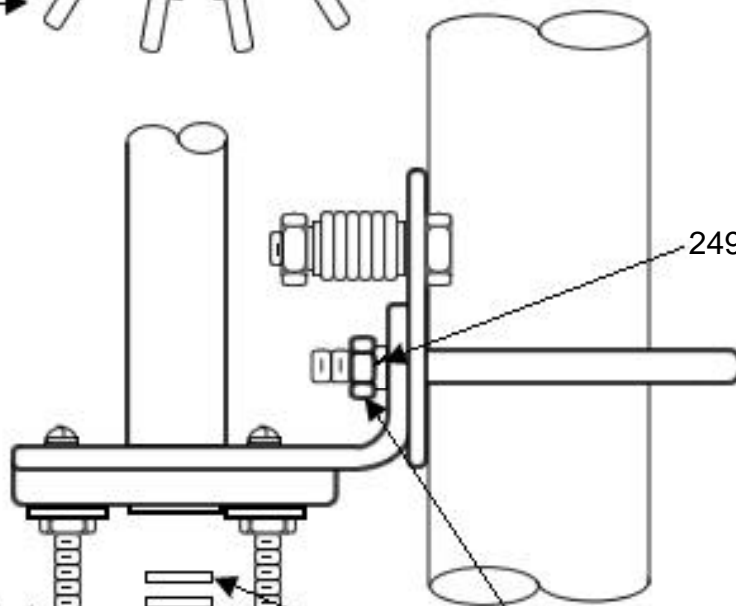

2491-5 Lockwasher

2233-41 Washer (2)

Shield

2381-10 Lockwasher

2382-1 Nut

Hot

Hot

2382-32 Hex Nut (2)

2233-33 Washer (2)

2491-5 Lockwasher (1)

2233-33 Washer (2)

2893-13 Screw

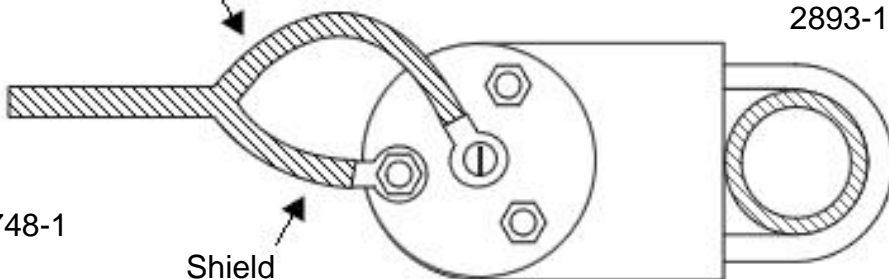

6748-1

Shield

**TIP ROD LENGTHS FOR 75 OR 80 METER RESONATORS
USED WITH 6-BTV**

Tip rod length measured from top of tip ball down to top of clutch locking nut as illustrated.

NOTE: All resonators are supplied with top rod lengths for mobile operation. With the 6-BTV, a shorter length is required, therefore, remove the tip rod from the resonator and grind off the necessary amount from the end that inserts in the resonator. Before cutting, ascertain the approximate rod length from the chart plus four inches for insertion in the upper tube section of the resonator.

Dimensions indicated are approximate.

<u>FREQUENCY (KHz)</u>	<u>RM-75S</u> <u>RM-80S</u>	<u>RM-75</u> <u>RM-80</u>
4000	18 in.	21-1/4 in.
3950	19-5/8 in.	22 in.
3900	21 in.	22-1/2 in.
3850	22-1/2 in.	23-3/4 in.
3800	24-1/8 in.	24-3/4 in.
3750	25-5/8 in.	26 in.
3725	26-1/2 in.	26-3/4 in.
	(Novice Band)	(Novice Band)
3700	27-1/4 in.	27-3/4 in.
3650	29 in.	29-1/4 in.
3600	30-5/8 in.	31 in.
3550	33 in.	33 in.
3500	34-5/8 in.	34-3/4 in.

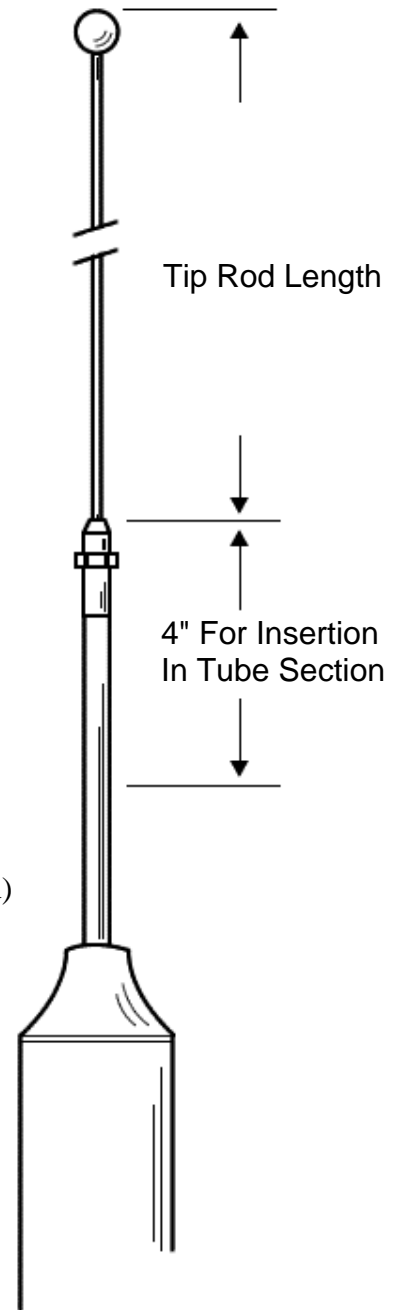

The above dimensions are exposed lengths of tip rod.

INSTALLATION

There are two mounting choices.

1. **Ground Mount**

In most areas with normal soil moisture, the 6-BTV can be ground mounted without a radial system.

To ground mount your antenna, use a 4 foot metal pipe or mast of 1-1/4 in. O.D. Drive it into the ground, leaving 18 in. protruding. Do not use concrete. Do not dig a hole and bury the mast. It must be driven in.

Follow assembly steps 1-6 before mounting the bracket on the mast. The bracket assembly should be placed on the mast so that the feed-point is 4 in. above the ground.

After tuning the antenna, compare your A, B, C, D, and E dimensions to the initial dimensions used to assemble the antenna. If your actual dimensions (after tuning) are shorter than the initial dimensions, your ground plane is better than average. If, on the other hand, your actual dimensions are longer, your ground plane is poorer. If this is the case, radials are suggested. Consult page 9 for radial length and configuration. The radials should be buried 2-3 inches underground.

2. **Elevated Mount**

Elevated mounts provide height which, in turn, will generally provide better reception and transmission.

Radials are necessary on elevated installations. The ideal droop angle is 45 degrees. A droop angle of 10 degrees to 60 degrees is acceptable. Plan the height of the mount to allow the best droop angle. Consult page 9 for radial information. When installing the radials avoid running them parallel (within 5 feet) to large masses of metal such as chain link fences, metal buildings, etc.

The 6-BTV can be mounted on a tower, a heavy duty chimney strap, wooden or metal pole, or other suitable support structure.

CAUTION: Mounting the 6-BTV on towers, tripods, or large mast pipes, approximately a quarter wave length, can often provide an upset to the counterpoise created by the radial system, and act as a vertical dipole instead of the desired ground plane. To correct this problem, the radial system must be RF isolated from the mounting structure. This may be done by using a non-conductive mounting mast, such as heavy wall fiberglass tube or fiberglass rod or by sliding a split piece of PVC pipe over the metal mast. The coax or mounting bracket should not be directly grounded.

In either mount configuration the 6-BTV must be guyed. Attach the guys above the 20 meter trap.

RADIALS

Radials should be made from insulated wire of #14 gauge or larger. Insulating the bare ends of wire on the outer end of the radial. A minimum of 2 radials per band is required.

Radial lengths are as follows:

10 meters	8' 4"
15 meters	11' 4"
20 meters	16' 4"
30 meters	23' 4"
40 meters	32' 4"
75/80 meters	64' 4"

Normal Configuration

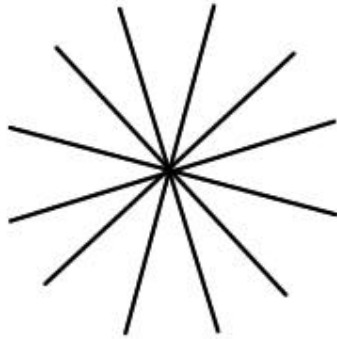

Limited Space Configuration

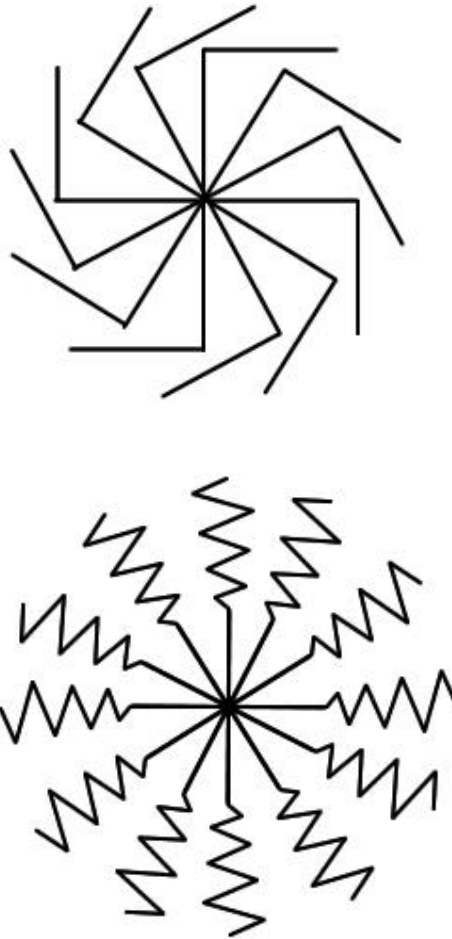

TUNING FOR ALL CHOICES:

The dimensions given in the Table are approximate and will vary, depending on environment. To check antenna tuning, use a sensitive SWR bridge. (DO NOT USE A FIELD STRENGTH METER.) Using only sufficient power to obtain a full scale reading, check and record the SWR at the high, center and low edge of the bands. If the SWR reading is lowest at the high end, lengthen the related section of the antenna; if it is lowest at the low end, shorten this antenna section. Always attempt to get the very lowest SWR reading in the center of the band. Tuning in this manner will permit operation in both the phone and CW portions with a low SWR. If you favor one end of the band or the other, you can retune the antenna to provide the lowest SWR in that portion, if desired.

In the process of tuning the antenna, it is mandatory that you always start with 10 meters and work your way up the antenna. Tune 10 first, then 15, 20, 30, 40 and 75/80 meters last. Any adjustment made on 10 will affect the other bands. Any adjustment made on 15 will affect 20, 30 and 40. By the same token, any adjustment on 20 will affect 30 and 40. Adjustment of the individual bands is as follows: 10 meters, adjust Dimension A; 15 meters, adjust Dimension B; 20 meters, adjust Dimension C; 30 meters, adjust Dimension D and 40 meters, adjust Dimension E.

It is not necessary to remove the bracket each time to adjust the antenna. It is only necessary to remove the antenna from the bracket. (If the desired SWR cannot be achieved, it is probably because of an insufficient counterpoise system or poor soil conditions.)

Follow the same tuning procedure for 75/80 meters, adjusting the tip rod of the resonator by loosening the nut and moving the tip rod. The sleeve on the tip rod can be moved to mark the correct tuning position.



New-Tronics Antenna Corp.
One Newtronics Place
Mineral Wells, TX 76067-9563
940-325-1386

GENERAL HINTS

If you are unable to achieve a low VSWR:

Be certain the antenna is not within 15 feet of metallic objects or 10 feet of non-metallic objects.

The decoupling coil on page 12 should be used. This is especially recommended if TVI is present.

If your antenna is elevated, with radials, be certain the mounting bracket is insulated from the mounting mast. The RF ground created by the radial system should not be electrically connected to earth or DC, ground.

If you are using radials, be certain they don't run parallel to large metallic objects such as fences. Also avoid metallic objects near the ends of the radials. The ends of the radials should be insulated.

Do not use ground rods or ground stakes. They may detune the antenna.

Never bunch radials together. They must be evenly spaced around 360 degrees.

Do not attempt to tune the antenna by changing coax length. Changing coax length may make the VSWR appear better, but will not change the antenna or its performance.

Antenna tuners are not recommended. Use of a tuner treats the symptom (poor VSWR) but does not correct the problem of a poorly tuned antenna. The antenna must be tuned properly to radiate efficiently.

Ground mounted antennas should be on a 4 ft. mast only. Masts of other lengths may resonant at an amateur frequency or a multiple thereof, detuning the antenna.

SPECIAL APPLICATIONS

The 6-BTV can be mounted on metal buildings, RV's or other structures, utilizing the metal for a ground plane. The feed point of the antenna should be 4" above the metal ground plane. Use the ground mount dimensions for the initial setup.

The 6-BTV is designed for the average ground plane. As the ground plane increases, the antenna becomes shorter. For this reason it may be necessary to trim some sections in order to reach resonance.

Since your coax shield is connected to where a radial would connect, it too will act as a radial. This is not desirable since this imposes additional currents which will detract from the antennas low V.S.W.R. at the rig end of your coax.

To prevent this from occurring, form at the bottom of the antenna or within eight feet of the base, a coil in your coax. By wrapping your coax in a single layer fashion, ten times around a 6" diameter form, you will form an R.F. choke in the braid which will isolate these additional currents from your coax.

Since your coax (the shield) is in the R.F. near field of your antenna, it will act as a collector of R.F. energy (an antenna). This too is not desirable since this can impose similar additional currents which will register as a higher V.S.W.R. at the rig.

To prevent this, form the same type coil as before at/or within eight feet of your rig.

These coils will NOT impede the R.F. energy contained inside the coax from flowing. It only acts as high impedance to the undesirable additional currents on the outside braid of your coax.

After having installed these coils, you may need to retune the antenna.

If you still have a high V.S.W.R., perhaps tuned radials are needed.

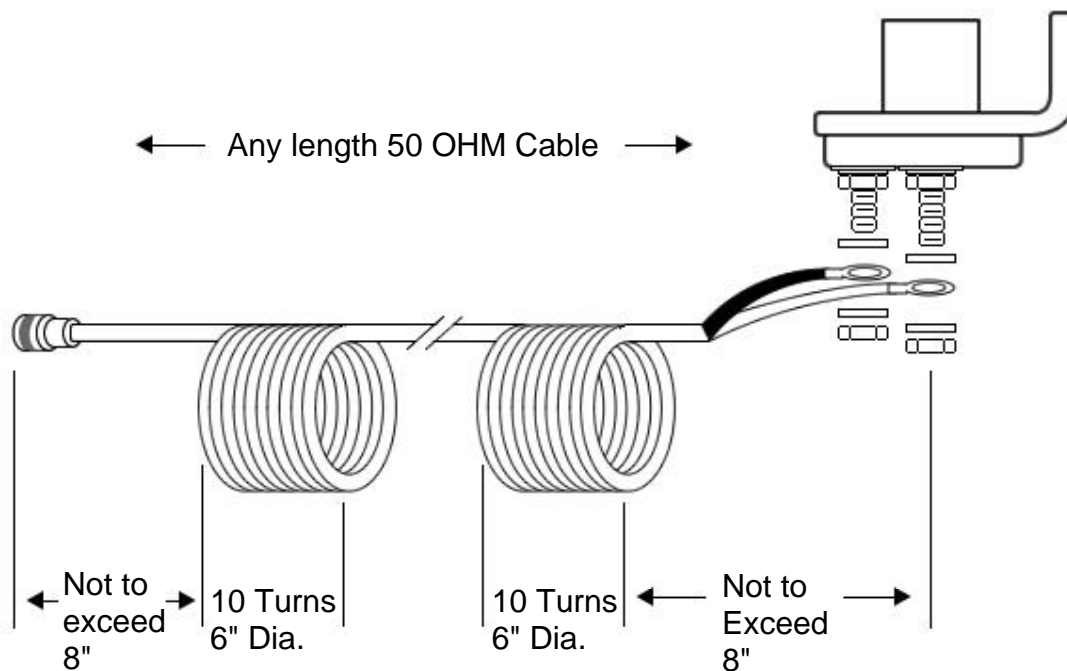

NEWTRONICS ANTENNA CORP.

Newtronics Antenna Corp. warrants its products to be free of defects in material and workmanship and extends this warranty under intended use and normal service conditions to the original owner for a period of one year from the date of purchase.

This warranty does not apply to any product that has been repaired or altered in any manner and is void for any damage due to accident, neglect, unreasonable use, improper installation of any other cause not arising out of defects in material of workmanship.

The obligations of Newtronics Antenna Corp. are limited to repairing or replacing, at its option, any product or part that is returned to the factory, all transportation charges prepaid, accompanied by proof of purchase and which examination reveals to have been defective within the warranty period stated above. Newtronics Antenna Corp. does not assume nor is any person authorized to assume for it, any obligations other than that herein stated. Any implied warranties, including but not limited to fitness for a particular purpose, are limited in duration for the above one year period. Newtronics Antenna Corp. shall not be liable under this warranty, or any implied warranty, for loss of use of the product or for other consequential loss or damage incurred by the purchaser.

Some states do not allow the exclusion of limitation of implied warranties of consequential damages and so the above exclusions of limitations may not apply. This warranty gives you special legal rights and you may have other rights that vary from state to state.



One Newtronics Place
Mineral Wells, Texas 76067-9563