

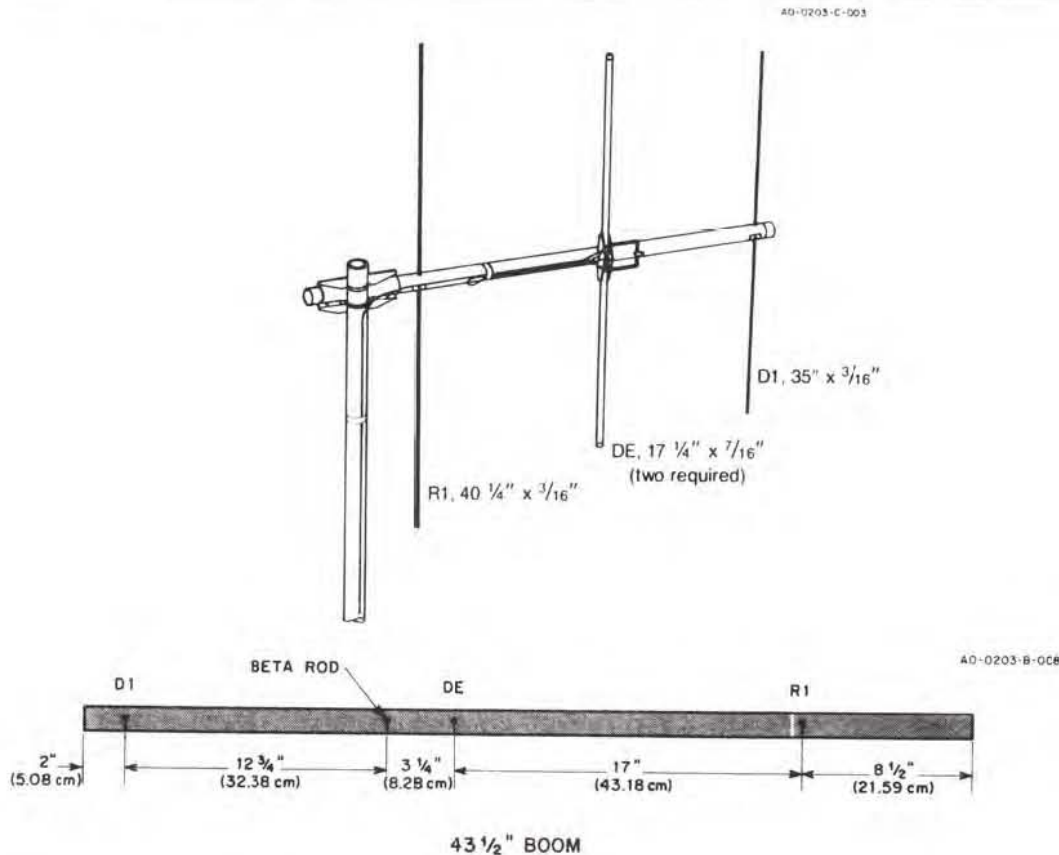
**INSTRUCTION  
MANUAL**

**ORDER NO. 203S-1**

**MODEL 23B-S**

**3-Element, 2-Meter Beam**

PN 801311-2



**Figure 1**  
**Overall View and Boom Detail**

**GENERAL DESCRIPTION**

This two meter beam consists of three elements mounted on a 43½" boom. The antenna features extremely high front-to-back ratio (F/B), with maximum obtainable gain. The high F/B is useful in hidden transmitter hunts and for rejection of unwanted signals. The antenna is end mounted, giving it the advantage of no mast decoupling and broad frequency response. This antenna features stainless steel hardware for all electrical and most mechanical connections, and now includes a NEW boom-to-mast bracket for masts 1⅝" to 2⅛" O.D.

**SPECIFICATIONS**

*Mechanical*

- Boom Length ..... 43½" (1105 mm)
- Longest Element ..... 40¼" (1022 mm)
- Net Weight ..... 2.2 lbs. (1.0 kg)
- Turning Radius (max.) .... 43½" (1105 mm)
- Wind Survival ..... 80 mph (129 kmph)
- Mast Diameter ..... 1⅝" to 2⅛"  
(41 mm to 53 mm)
- Boom Diameter ..... 1¼" O.D. (32 mm)
- Wind Area ..... 0.395 sq. ft. (0.04 m²)  
(horizontal)  
0.446 sq. ft. (0.05 m²) (vertical)

*Electrical*

Gain (average)..... 8.3 dBi (6.1 dBd)  
 Front-to-Back Ratio ..... 20 dB  
 SWR (max.)..... 2:1  
 Band Width ..... 4 MHz  
 Maximum Power..... 250 watts continuous,  
 500 watts P.E.P.  
 Impedance ..... 50 ohms (with balun)  
 Half-Power Beamwidth ..... 95° (vertical  
 polarization), 60° (horizontal  
 polarization)

**SWR AND FEEDLINE**

The 203S-1 antenna has an input impedance of 200 ohms. The supplied balun matches the input to 50 ohms. If you are using a transmission line with a characteristic impedance other than 50 ohms or 200 ohms, a matching device must be made. Refer to any current Amateur Handbook for information on constructing a matching device.

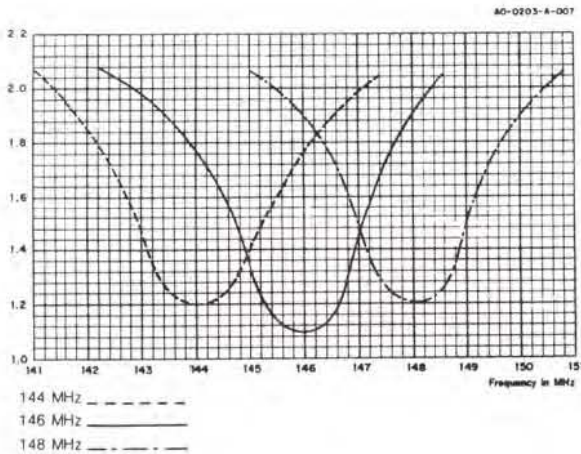
**TUNING**

**NOTE:** The Driven and Parasitic Elements are adjusted independently in the following manner:

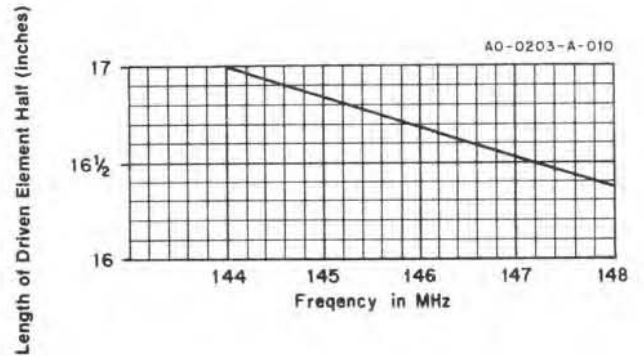
**Parasitic Elements:** This antenna is pretuned for maximum gain and best radiation pattern at 146 MHz. This setting will give optimum performance over the entire 144-148 MHz band.

If you wish to optimize the antenna for a frequency higher than 146 MHz, cut ¼" off of the total element lengths for each MHz higher than 146.

**Driven Element:** SWR can be lowered to less than 1.2:1 at a desired frequency by carefully trimming the driven element. Keep the element symmetrical by cutting the same amount from each side. Typical SWR curves are shown in Figure 2A and a cutting chart is shown in Figure 2B. Each installation is slightly different, so cut the driven element for the lower SWR at your particular location. Measure the SWR as close to the antenna as you can for accurate results.

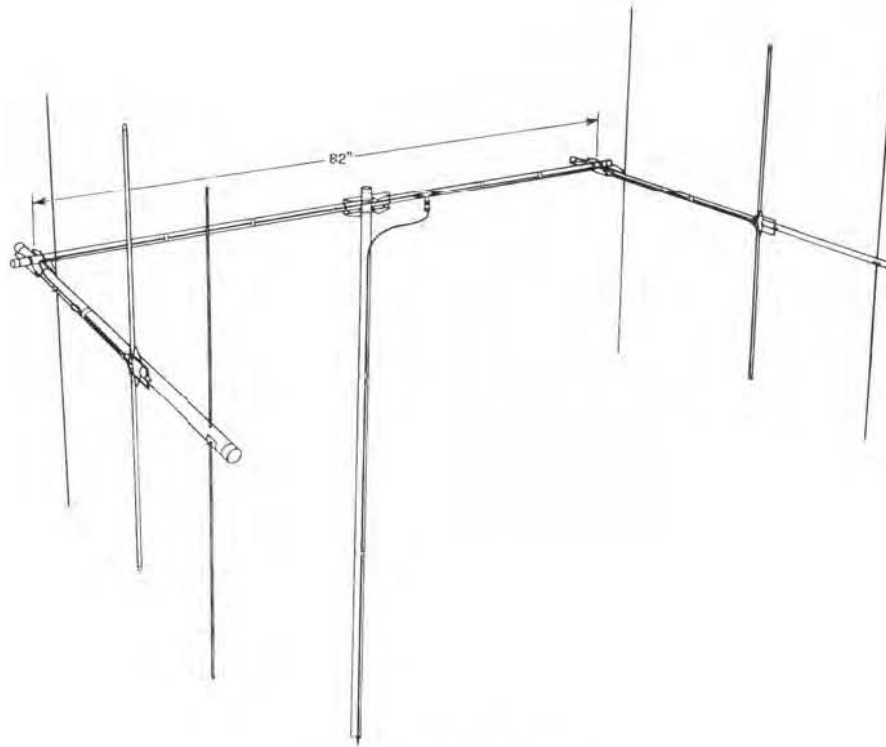


**Figure 2A**  
**VSWR for Both Horizontal and Vertical Polarization**



**Figure 2B**  
**Driven Element Cutting Chart**

**Figure 2**  
**VSWR for Both Vertical and Horizontal Polarization**



**Figure 3**  
**Stacking Two (2) Antennas**

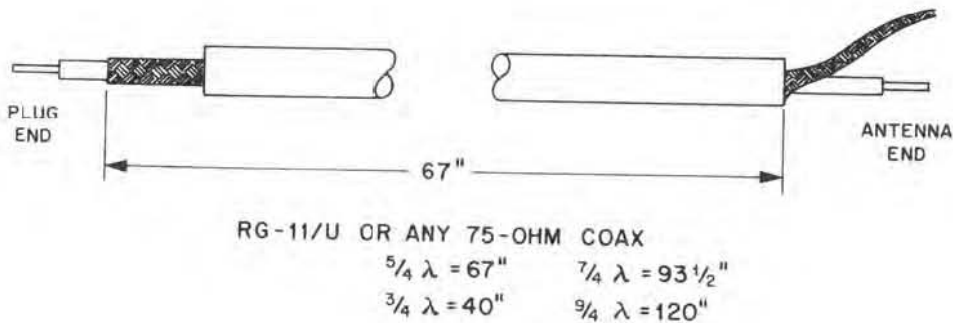
**STACKING**

This antenna can be easily stacked for approximately 3 dB more gain each time the number of yagi is doubled. Refer to Figure 3 for stacking and phasing harness cutting information.

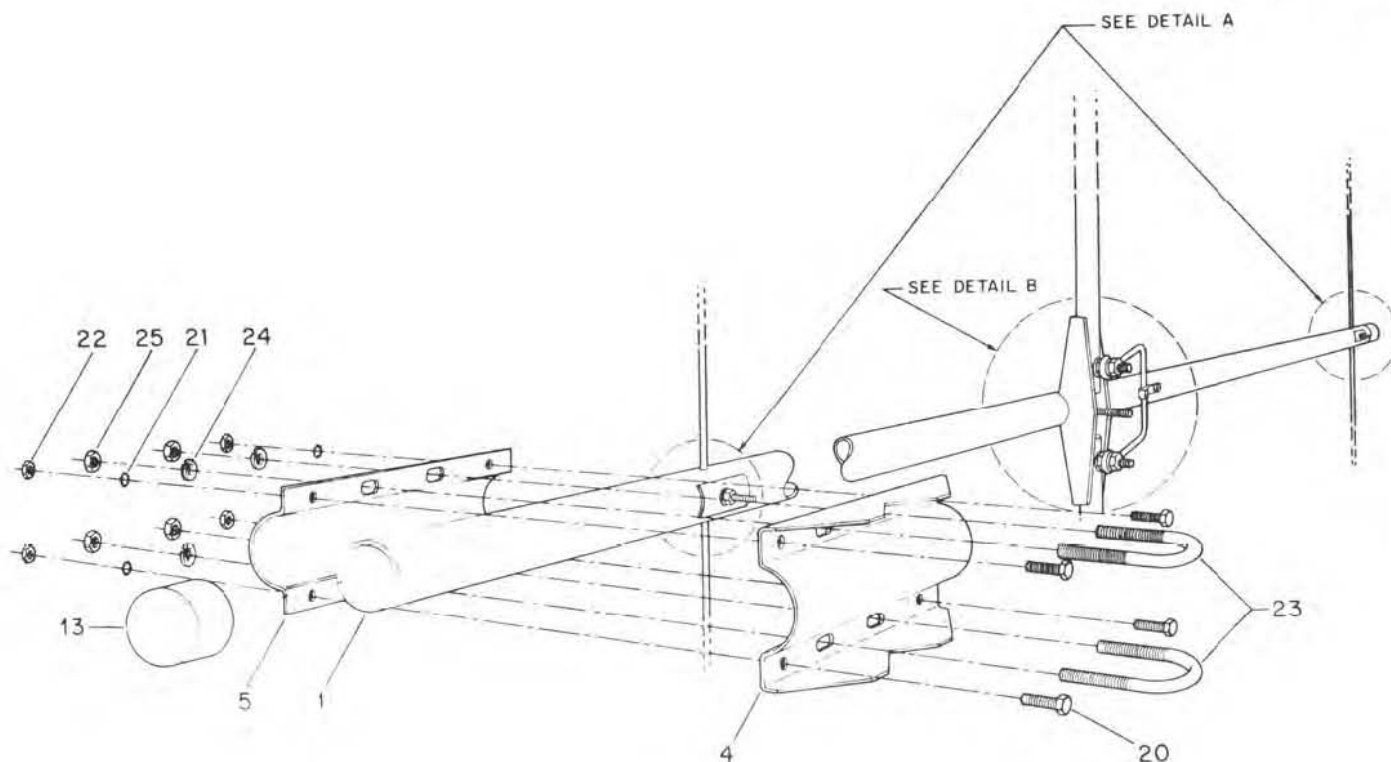
The two phasing lines coming from the two antennas to the "T" connector can be any odd multiple of one-quarter wavelength in the 75 ohm transmission line. See Figure 4.

**NOTE:** When phasing two antennas, the Driven Element halves that are connected directly to the phasing lines should be on the same side of the array.

The feedline impedance is for 50 ohms (RG-213/u). For detailed information on stacking more than two yagis, please consult any current Amateur handbook.



**Figure 4**  
**Phasing Line Cutting Dimensions**



Item No.	Description
1	Boom, 1¼" x 43½"
4	Boom-to-Mast Clamp
5	Back-Up Plate
13	Caplug, 1¼", black
20	Bolt, hex head, ¼"-20 x ¾"

Item No.	Description
21	Lockwasher, internal, ¼"
22	Nut, hex, ¼"-20
23	U-bolt, 5/16" x 2¼/16" x 35/8" (ZCI)
24	Lockwasher, split, 5/16"
25	Nut, hex, 5/16"-18

**Figure 5**  
**Boom-to-Mast Clamp Assembly**

## INSTALLATION

This antenna fits a 1½" to 2¼" mast. A 2" O.D. pipe is recommended for a sturdy mast.

Mount the antenna in the clear. Surrounding objects, particularly power lines and other objects of considerable mass or length are detrimental to the performance of the antenna.

## WARNING

**Do not allow any part of the antenna to touch power lines. This could cause severe burns or fatal injuries.**

When mounting two dissimilar antennas on the same mast, be sure they are separated by at least six feet — eight to ten feet is even better.



The antenna can be mounted either vertically or horizontally for 146-148 MHz or 144-146 MHz respectively. Circular polarization can be obtained by using two yagis. For information about which polarization is best, consult local Amateurs who use the frequencies you desire.

### STEP-BY-STEP ASSEMBLY

Remove the parts from the carton and check them against the Parts List and the illustrations.

Select the boom backup plate, the boom-to-mast bracket and the four (4)  $\frac{1}{4}$ "-20 x  $\frac{3}{4}$ " bolts, lockwashers and nuts.

Place the boom-to-mast bracket on the boom as shown in Figure 5. Use the  $\frac{1}{4}$ "-20 x  $\frac{3}{4}$ " bolts in the outside holes. Leave the inside holes for the two U-bolts, which will be used later for mounting the mast. Select either the vertical or horizontal mounting position. Adjust the boom accordingly before tightening the bolts securely.

Select the R1 ( $40\frac{1}{4}$ " rod). Use a pencil to place a mark at the center of the rod ( $20\frac{1}{8}$ " ) from either end. Place two more marks  $\frac{5}{8}$ " on each side of the center mark.

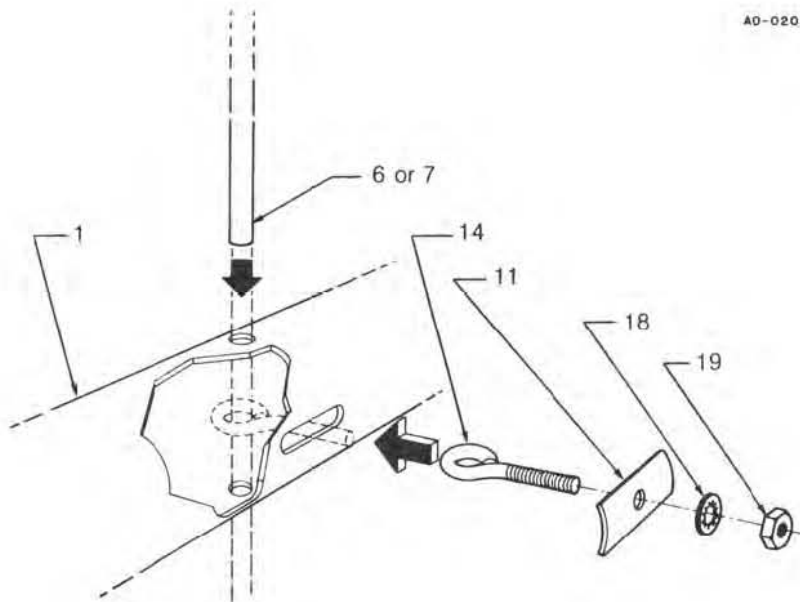
Place a #10-24 x  $1\frac{1}{2}$ " eyebolt into the R1 slot as shown in Figure 5, Detail A. Slide the R1 through the holes and the eyebolt until the outer two marks on the R1 are visible on each side of the boom. Slip on an aluminum half-washer, lockwasher and a #10 nut. Tighten it just enough to hold the rod securely.

Select the element-to-boom insulator, two sections of the Driven Element (DE) ( $\frac{7}{16}$ " x  $17\frac{1}{4}$ " tubing) and the beta rod. **DO NOT OVER TIGHTEN.**

**NOTE:** If 50 ohm coaxial cable is used to feed the antenna, select the supplied balun at this time. Wrap the balun with tape at three locations as shown in Figure 5, Detail B.

Use the #10-24 x  $2\frac{1}{2}$ " bolt to fasten the element-to-boom insulator to the boom. Refer to Figure 5, Detail B.

AO-0203-A-004



Item No.	Description
1	Boom, $1\frac{1}{4}$ " x $43\frac{1}{2}$ "
6	D1, $35$ " x $\frac{3}{16}$ "
7	R1, $40\frac{1}{4}$ " x $\frac{3}{16}$ "
11	Half-Washer, aluminum

Item No.	Description
14	Eyebolt, #10-24 x $1\frac{1}{2}$ " x $\frac{5}{16}$ "
18	Lockwasher, internal, #10
19	Nut, hex, #10-24

**Figure 5 — Detail A  
Parasitic Element Attachment**

Use the two (2) #10-24 x 1 1/4" bolts to assemble the Driven Element as shown in Figure 5, Detail B. Pay particular attention to the connections of the beta rod, balun and feedline.

Waterproof the connection with neoprene or a silicone type sealing compound.

Install caplugs on the ends of the boom and the Driven Element.

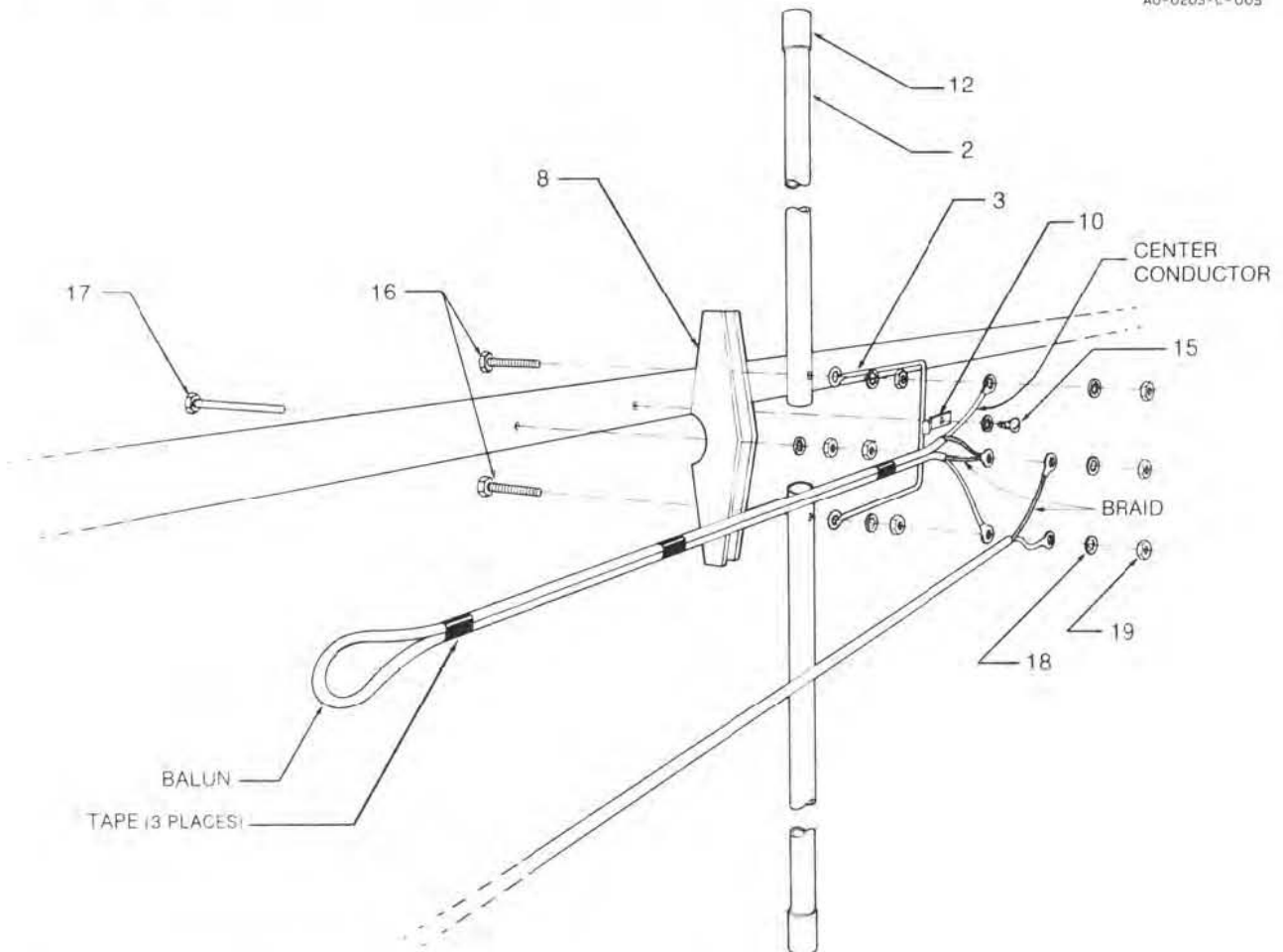
Use the #10 x 3/8" screw to fasten the beta rod shorting clip over the beta rod, as shown in Figure 5, Detail B.

Select the D1 (35") and secure to the boom, using the same procedure as was done with the R1. The center of the D1 is 17 1/2" from either end.

Slip the two (2) U-bolts into the boom-to-mast bracket and fasten it to the mast securely.

Tape the coax feedline and balun to the boom and to the mast. Be sure to insulate any connections from the boom or the mast. This completes your installation.

A0-0203-C-005



Item No.	Description	Item No.	Description
2	DE, 7/16" x 17 1/4"	15	Screw, pan head, #10 x 3/8", Type A
3	Beta Rod, 3"	16	Bolt, hex head, #10-24 x 1 1/2"
8	Insulator (DE-to-Boom)	17	Bolt, hex head, #10-24 x 2 1/2"
10	Beta Clip	18	Lockwasher, internal, #10
12	Caplug, 7/16", with hole	19	Nut, hex, #10-24

**Figure 5 — Detail B**  
**Driven Element, Beta Match and Balun Assembly**

## PARTS LIST

Item No.	Part No.	Description	Qty
1	160039	Boom, 1¼" x 43½"	1
2	175157	DE, 7/16" x 17¼"	2
3	160040	Beta Rod, 3"	1
4	385142-1	Boom-to-Mast Clamp	1
5	385144-1	Back-Up Plate	1
6	160023	D1, 35" x 3/16"	1
7	160038	R1, 40¼" x 3/16"	1
8	465420	Insulator (DE-to-boom)	1
9	871704	Balun Assembly	1
	872074-1	Parts Pack 203S-1, Stainless Steel	1
10	163266	Beta Clip	1
11	170376	Half-Washer, aluminum	2
12	475639	Caplug, 7/16", with hole	2
13	455630	Caplug, 1¼", black	2
14	540065	Eyebolt, #10-24 x 1½" x 5/16"	2
15	510670	Screw, pan head, #10 x 3/8", Type A	1
16	500159	Bolt, hex head, #10-24 x 1½"	2
17	500164	Bolt, hex head, #10-24 x 2½"	1
18	565697	Lockwasher, internal, #10	10
19	554071	Nut, hex, #10-24	9
20	505266	Bolt, hex head, ¼"-20 x ¾"	4
21	562961	Lockwasher, internal, ¼"	5
22	554099	Nut, hex, ¼"-20	4
23	540067	U-bolt, 5/16" x 2½" x 3 5/8" (ZCI)	2
24	564792	Lockwasher, split, 5/16"	4
25	555747	Nut, hex, 5/16"-18	4

### CONVERTING ENGLISH MEASUREMENTS TO METRIC

Use this scale to identify lengths of bolts, diameters of tubes, etc.. The English inch (1") and foot (1') can be converted to centimeters in the following way:

$$1 \text{ inch (1")} = 2.54 \text{ cm}$$

$$1 \text{ foot (1')} = 30.48 \text{ cm}$$

Example:

$$42" \times 2.54 = 106.7 \text{ cm}$$

