



# ORDER NO. 383S

Model 5BDQ-S, Doublet Antenna  
with Stainless Steel Hardware

## INSTRUCTION MANUAL

### General Description

The Hy-Gain Model 5BDQ-S is a half-wavelength doublet antenna for 10, 15, 20, 40, and 80 meters. Matched Hy-Gain Hy-Q traps allow automatic band switching. The 15-20 meter wire is fanned below the 10-40-80 meter wire to minimize loading. The maximum overall length is 93' 8".

To further improve the performance of the 5BDQ-S, a Hy-Gain balun Model BN-86 is recommended. The Model BN-86 is a broad-band balun designed specifically for doublet type antennas. It will balance the input impedance to the antenna and prevent transmission line radiation to increase the efficiency of a doublet type antenna.

### Construction

The Hy-Q traps are weather resistant. All hardware is stainless steel. The center of the doublet is supported by a yoke-type center insulator to which the transmission line attaches. The ends of the doublet are supported by end insulators constructed of high impact Cicolac® plastic. The antenna wire is Alumoweld® #12 which has a breaking strength of 1200 pounds. It will not rust or corrode. See "Hints on Handling Alumoweld® Wire" in the rear of this manual.

### SWR and Feedline

The Model 5BDQ-S antenna is designed for use with a single 50-ohm coaxial feedline. The SWR at resonance is 1.5:1 or less on all bands. Either RG-58/U or RG-8/U can be used. RG-8/U polyfoam type is recommended because of its lower losses and higher power handling capabilities.

Specifications	
<i>Mechanical</i>	
Overall Length	93' 8" maximum (48.67m)
Maximum Wind Survival	80 mph (129 kmph)
Antenna Wire	Alumoweld® #12
<i>Electrical</i>	
Frequency Range	10,15,20,40, and 80 Meters
Input Impedance	50 ohms unbalanced
SWR at Resonance	Less than 1.5:1
Maximum Power	1 kW AM, 2 kW PEP

Cicolac® is a registered trademark of Borg Warner

Alumoweld® is a registered trademark of Copperweld Bimetallic Group

## Installation Notes

Suspend the antenna by attaching the end insulators to a stable structure. The center insulator may be supported by the antenna itself or suspended from a support. When suspending the center insulator from a support, the insulator must not contact any of the supporting structure. For proper operation of this antenna, the center insulator should be at least 46' above the ground. As a general rule, the higher the antenna the better the operation.

The antenna should be mounted in the clear. Detrimental effects of surrounding objects is often underestimated in the average antenna installation. Power lines and other metal objects of considerable length or mass will deteriorate the performance of any antenna.

When installing the antenna, keep the two halves balanced with respect to ground and surrounding objects. Do not attempt to remove all the sag, or tremendous strain will develop which could cause mechanical failure. A few feet of sag in the center will not harm the antenna either electrically or mechanically.

When suspending the antenna, keep the 10-4080 meter wire as nearly horizontal as possible and fan the 15-20 meter wire below it, observing the maximum and minimum separation distance as shown in Figure 1. The lower ends of the antenna must be at least 16 feet above the ground. Keep the ends of the antenna balanced, that is, anything you do to one end must also be done to the other end or serious deterioration in performance will result. The 100 feet of rope is included with the antenna for suspending the end insulators. The end insulators have two different sized holes. The largest hole is for attaching the rope. If it is necessary to use additional suspending material, you should use non-metallic rope. If wire is used, it must be broken up every 6 feet with strain insulators to prevent harmful effects to your radiation pattern.

Frequency Coverage Chart

Setting	10 Meters	15 Meters	20 Meters	40 Meter	80 Meters
Low CW	28.0-28.5	21.00-21.25	14.0-14.2	7.0-7.2	3.50-3.65
High CW	28.0-28.5	21.00-21.25	14.0-14.2	7.0-7.2	3.65-3.80
Phone	28.5-29.0	21.25-21.45	14.2-14.35	7.2-7.3	3.80-4.00

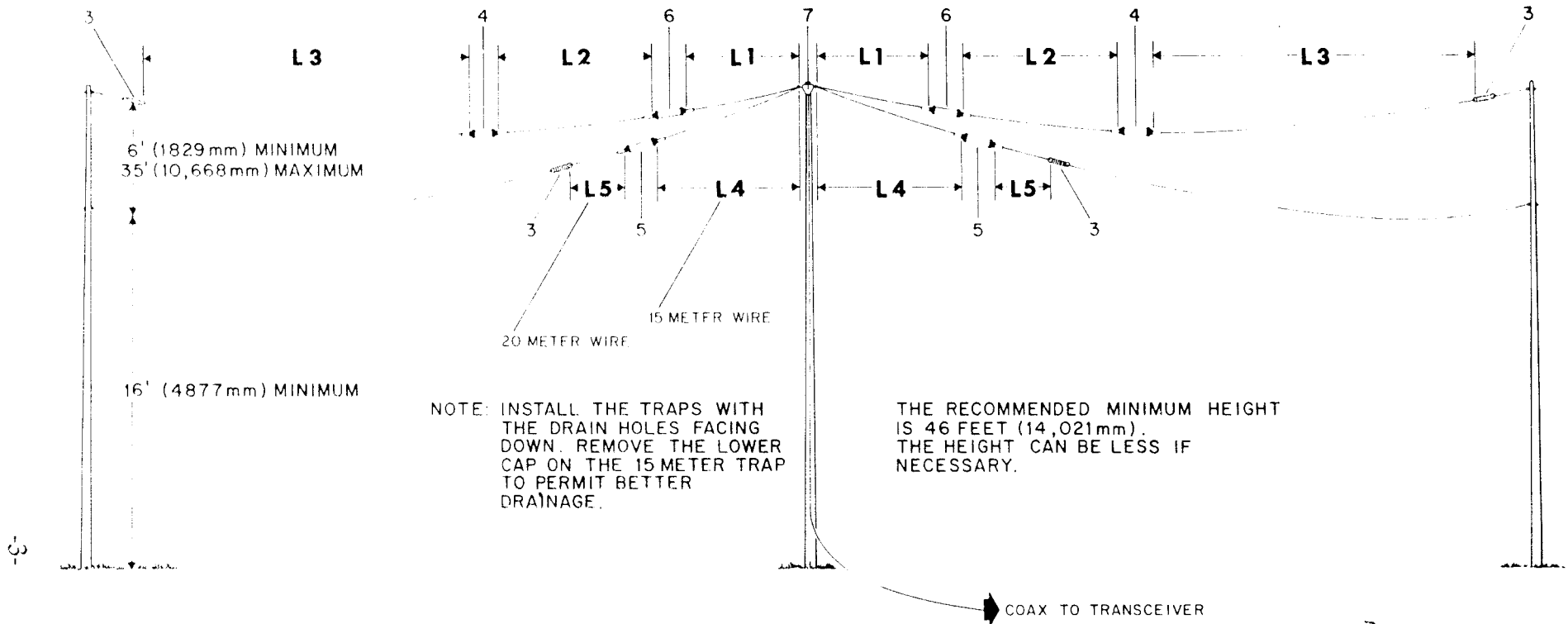

Mode of Operation	SECTION									
	L1		L2		L3		L4		L5	
	English	Metric	English	Metric	English	Metric	English	Metric	English	Metric
Low CW	6'	2013 mm	8' 5 1/2"	2578 mm	28' 9 3/4"	8782 mm	8' 7"	2616 mm	2' 11 3/4"	908 mm
High CW	6' 7 3/8"	2016 mm	8' 1"	2708 mm	25' 8"	7836 mm	8' 11"	2718 mm	2' 11 3/4"	908 mm
Phone	6' 2 3/4"	1899 mm	8' 7 3/4"	2635 mm	23' 4"	7118 mm	8' 10 1/2"	2715 mm	2' 11 3/4"	908 mm

Item

- 3 Insulator, end
- 4 Trap, 40-meter
- 5 Trap, 15-meter
- 6 Trap, 10-meter
- 7 Insulator, center

Figure 1  
Overall View of Erected Antenna

## Step-by-Step Assembly

Assemble the center insulator as shown in Figure 2. First place one half of the insulator on a flat surface with the inside facing up. Assemble the hardware on eyebolts and place in the insulator. Now, strip the coax and separate the center conductor from the braid. Solder the braid to one solder lug and solder the center conductor to the other solder lug. For smaller coax a reducing sleeve is provided. Apply silicone grease, Vaseline®, etc. (not supplied) to the mating insulator halves, place together and secure using the #6-32 x 3/8" bolts (14 in all). Hold the eyebolt so it does not turn and tighten the 1/4" nuts on the outside, first one side and then the other.

NOTE: Both sides of the antenna are exactly the same. Each of the following steps must be done first for one side and then repeated for the other side.

Cut the 10-meter wire (L1) to either Phone or Continuous Wave (CW) dimensions as shown in Figure 1. Add an extra 3 inches on each end for attaching to the center insulator and 10-meter trap.

Example: L1 length for Phone operation is 6' 2 3/4". Add 6 inches which makes a total length of 6' 8 3/4". Each insulator or trap requires about 3 inches for proper attachment.

NOTE: When you have selected your mode of transmission (Phone or CW), you must use the same mode for all dimensions.

Attach one end of the wire (just cut) to the center insulator using the wire locks as shown in Figure 2. Connect the pigtails to the wire lock.

Clip off all excess wire extending past the wire lock.

Select the 10-meter trap and the trap connector clamps. Assemble the clamps on both ends of the trap using the # 10-24 x 1 1/2 " bolts and lockwashers as shown in Figure 4.

Carefully re-measure the antenna wire connected to the center insulator and bend the wire for attachment to the 10-meter trap as shown in Figures 1 and 3.

Connect the wire to the trap using the wire locks as shown in Figure 4. Clip off all excess wire extending past the wire lock.

NOTE: The end of the trap where the part number is marked must be pointed toward the center insulator as shown in Figures 1 and 4. This is essential for proper operation of your antenna.

Cut the 40-meter antenna wire (L2) to the length shown for your mode of transmission (Phone or CW). Allow an extra 3 inches on each end for attachment to the 10-meter trap and 40-meter trap.

Bend one end of the wire and attach to the 10meter trap as shown in Figures 3 and 4. Clip off all excess wire extending past the

Carefully re-measure wire and bend for attachment to the 40-meter trap.

Select the 40-meter and the trap connector clamps. Assemble clamps on trap as shown in Figure 4.

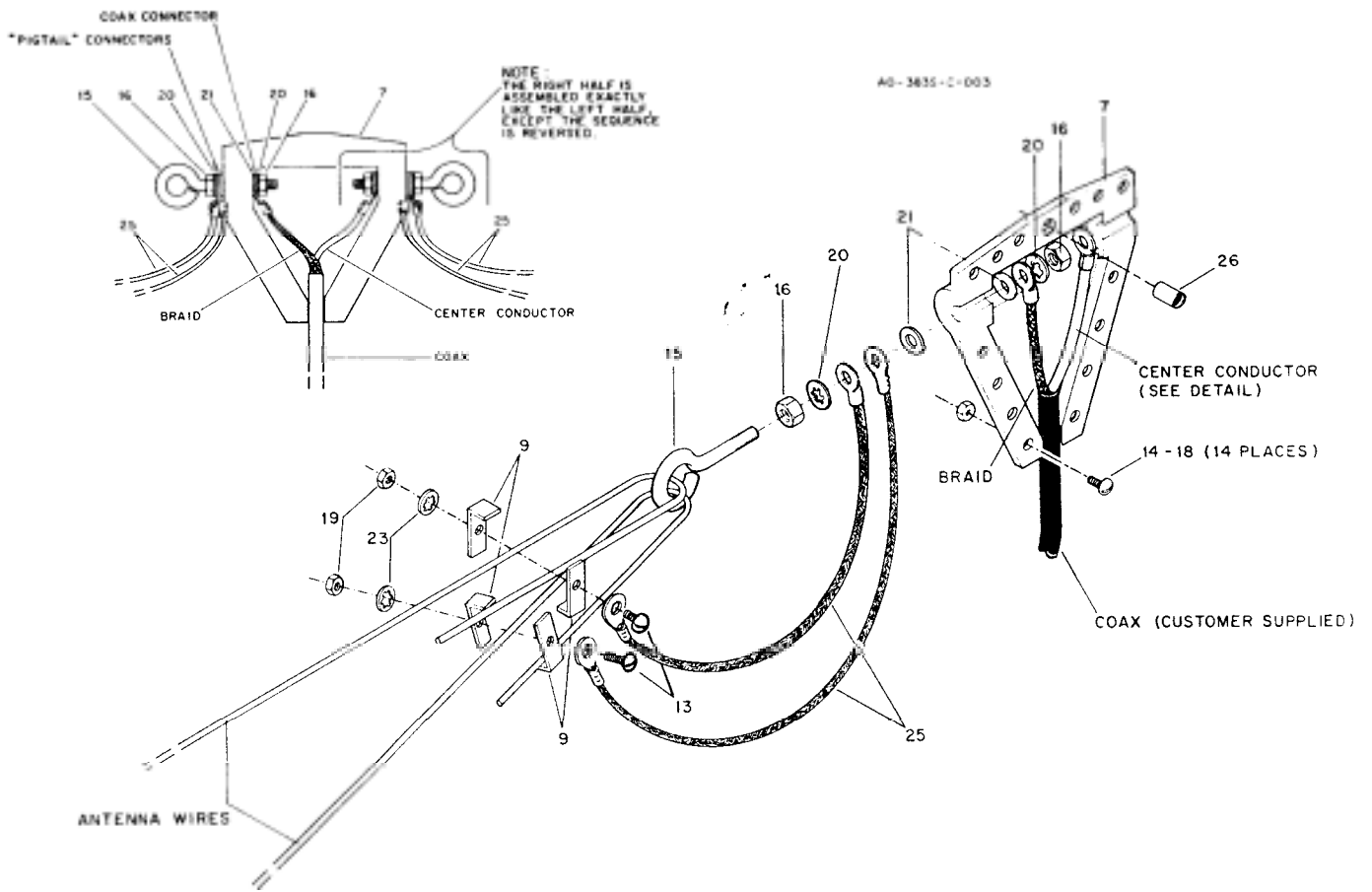

Item No.	Description	Item No.	Description
7	Insulator, center	19	Nut, Hex, #8-32, Stainless steel
9	Lock, wire	20	Lockwasher, internal, 1/4", stainless steel
13	Bolt, round head, #8-32 x 1/2", stainless steel	21	Flatwasher, 1/4", stainless steel
14	Bolt, round head, #6-32 x 3/8", stainless steel	23	Lockwasher, internal, #8, stainless steel
15	Eyebolt, 1/4" x 1 1/2", 1/2" eye, stainless steel	25	Assembly, Pigtail
16	Nut, hex, 1/4"-20, stainless steel	26	Sleeve, mounting hole
18	Nut, hex #6-32, stainless steel		

Figure 2 Assembly of Antenna Wire to Center Insulator

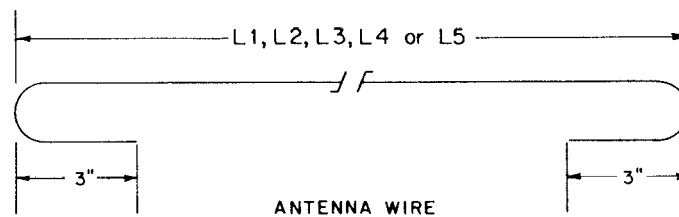

Figure 3 Antenna Wire Measurements

Connect the antenna wire (other end connected to 10-meter trap) to the 40-meter trap as shown in Figures 1 and 4. Be sure that the end of the trap with the part number marking is pointed towards the center insulator.

Cut the 80-meter antenna wire (L3) to the length shown for your mode of transmission (Phone or CW). Allow an extra 3 inches on each end for attachment to the 40-meter trap and end insulator.

Bend one end of the wire and attach to the 40-meter trap as shown in Figures 3 and 4. Clip off all excess wire extending past the wire lock.

Carefully re-measure the wire and bend for attachment to the end insulator.

Attach the wire to the end insulator as shown in Figure 5. Clip off all excess wire extending past the wire lock.

NOTE: The holes in the end insulators are of different sizes. The smaller hole must be used to connect the antenna wire and the larger hole will be used for attaching the suspending rope.

Assemble the remainder of the antenna in the same manner as described above. Refer to the illustrations for a guide. Remember to connect the pigtail from the center insulator to the 15-meter wire (L3) and make certain the 15-meter trap has the part number end pointed towards the center insulator.

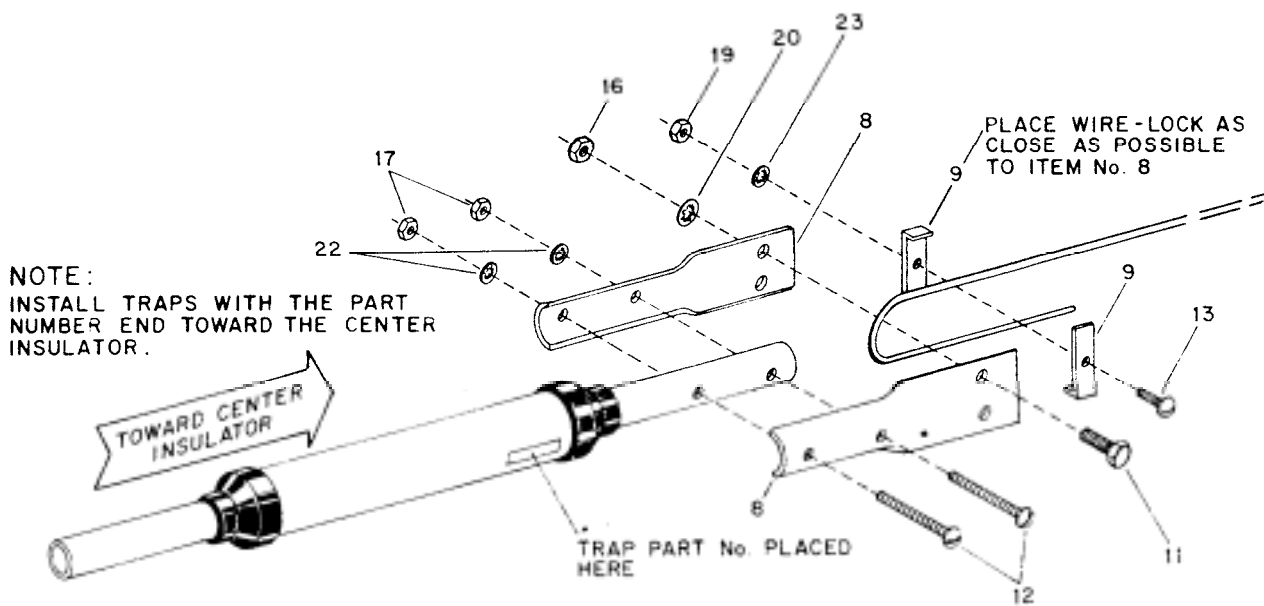

Item No.	Description	Item No.	Description
8	Clamp, Trap Connector	1	Nut, hex, #10-24, stainless steel
9	Lock, Wire	19	Nut, hex, #8-32, stainless steel
11	Bolt, hex head, 1/4"-20 x 3/4", stainless steel	20	Lockwasher, internal, 1/4", stainless steel
12	Bolt, round head, #10-24 x 1 1/2", stainless steel	22	Lockwasher, internal, #10, stainless steel
13	Bolt, round head, #8-32 x 1/2", stainless steel	23	Lockwasher, internal, #8, stainless steel
16	Nut, hex, 1/4"-20, stainless steel		

Figure 4 Assembly of the Antenna Wire to the Trans

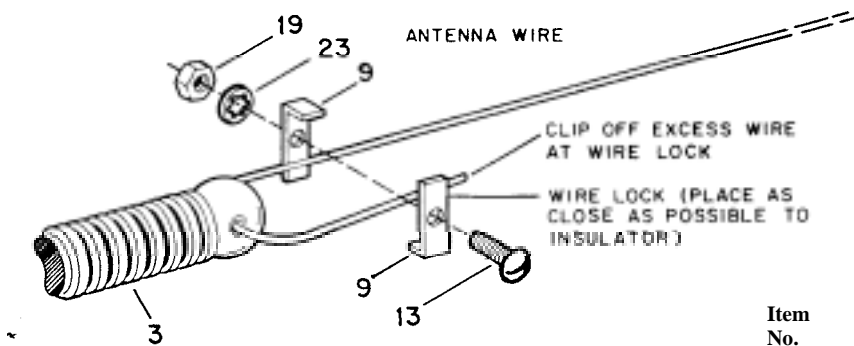

Item No.	Description
3	Insulator,
13	end Lock,
19	wire
23	Bolt, round head. #8-32 x 1/2". stainless

Figure 5 Assembly of the Antenna Wire to the End Insulator

Your 5BDQ-S is now ready to install. Again, carefully read the installation instructions before suspending the antenna.

#### Hints on Handling Alumoweld® Wire

Alumoweld® wire is a noncorrosive, high strength wire. It meets military specifications for virtually all environmental conditions. The wire is designed for areas of high humidity and salt exposures as well as areas of high corrosive content. Alumoweld® wire is more difficult to work with than other less durable forms of wire but the lasting properties are far superior. Conducting properties closely approach that of pure aluminum making it ideal electrically for RF use.

There may be some difficulty encountered in its frequency to kink. Kinks may be removed by a pole or similar stationary curved object and working the wire back and forth as shown below.

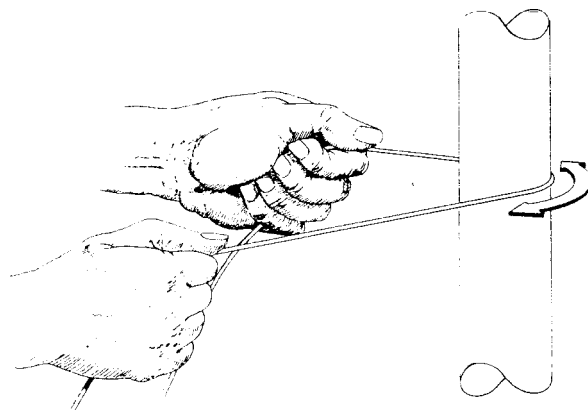

Figure 6 Removing Kinks from Alumoweld® Wire

## PARTS LIST

Item	Part No.	Description-	Qty
1	691136	Rope, polypropylene, 5/32" x 100' . . . . .	1
2	691458	Antenna Wire, Alumoweld(R), #12x 125' . . . . .	1
3	861021	Insulator, End . . . . .	4
4	877234	Trap, 40-Meter . . . . .	2
5	878462	Trap, 15-Meter . . . . .	2
6	878473	Trap, 10-Meter . . . . .	2
7	465460	Insulator, Center . . . . .	2
	878442-1	Parts Pack . . . . .	1
8	167236	Clamp, Trap Connector . . . . .	24
9	167238	Lock, Wire . . . . .	40
10	465570	Plug, Center Insulator Adaptor . . . . .	1
11	505266	Bolt, hex head, 1/4"-20 x 3/4", stainless steel . . . . .	12
12	500159	Bolt, round head, # 10-24 x 1 1/2", stainless steel . . . . .	24
13	500185	Bolt, round head, #8-32 x 1/2", stainless steel . . . . .	20
14	501118	Bolt, round head, #6-32 x 3/8", stainless steel . . . . .	14
15	540066	Eyebolt, 1/4" x 1 1/2", 1/2", eye, stainless steel . . . . .	2
16	554099	Nut, hex, 1/4"-20, stainless steel . . . . .	16
17	554071	Nut, hex, #10-24, stainless steel . . . . .	24
18	555888	Nut, hex, #6-32, stainless steel . . . . .	14
19	550063	Nut, hex, #8-32, stainless steel . . . . .	20
20	562961	Lockwasher, internal, 1/4", stainless steel . . . . .	17
21	566344	Flatwasher, 1/4", stainless steel . . . . .	4
22	565697	Lockwasher, internal, # 10, stainless steel . . . . .	25
23	560035	Lockwasher, internal, #8, stainless steel . . . . .	21
24	677555	Lug, solder . . . . .	2
25	878446	Assembly, Pigtail . . . . .	4
26	171586	Sleeve, Mounting Hole . . . . .	1

### Converting American Measurements to Metric

1 inch (1") = 2.54 cm

Use this scale to identify lengths of bolts, diameters of tubes, etc.. The American inch (") and foot (') can be converted to centimeters in the following way:

1 foot (1') = 30.48 cm

Example:

$42" \times 2.54 = 106.7$   
cm

