

~~XXXXXXXXXX~~

LA916A



244
Hy-Quad

INSTRUCTION MANUAL

HY-GAIN ELECTRONICS CORPORATION

Table of Contents

	page
General Description	1
Feedline	1
Installation Height and Site Selection	1
Specifications	1
Preparation for Installation	1
Reflector Spreader Arm Assembly	2
Horizontal	2
Vertical	4
Driven Element Assembly	4
Top Vertical Spreader Arm	4
Bottom Vertical Spreader Arm	4
Horizontal Spreader Arm Assembly	5
Assembly of Spreader Arms-to-Boom Sections	5
Compression Clamp Assembly	6
Driven Element	6
General Assembly Outline	9
Detailed Assembly Instructions	9
Stringing Element Wire	11
Phone By-Pass	14
Element Tension	14
Gamma Match Assembly	16
Assembly of the Boom	17
Final Preparations	18
Parts List	18

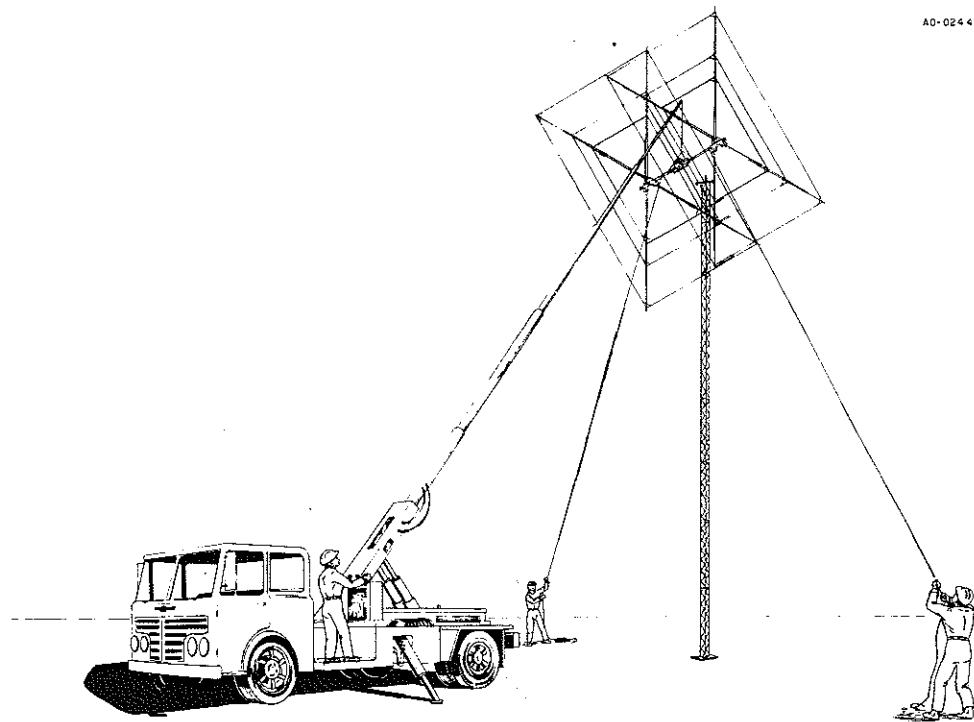
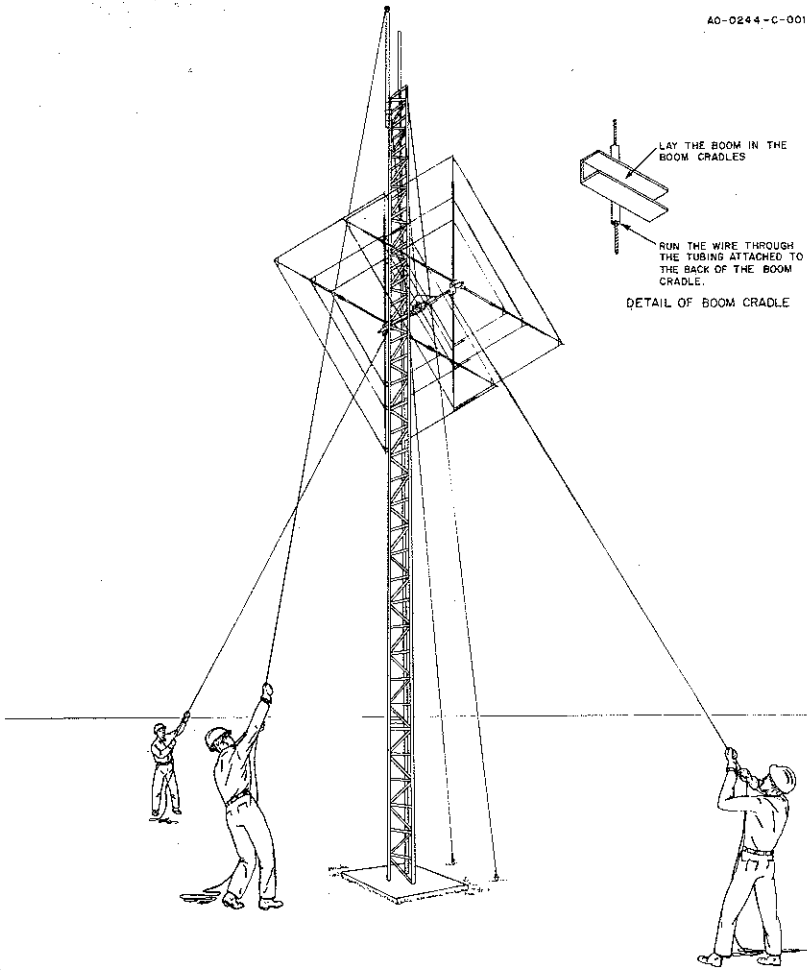

Figure 1. Antenna Erection

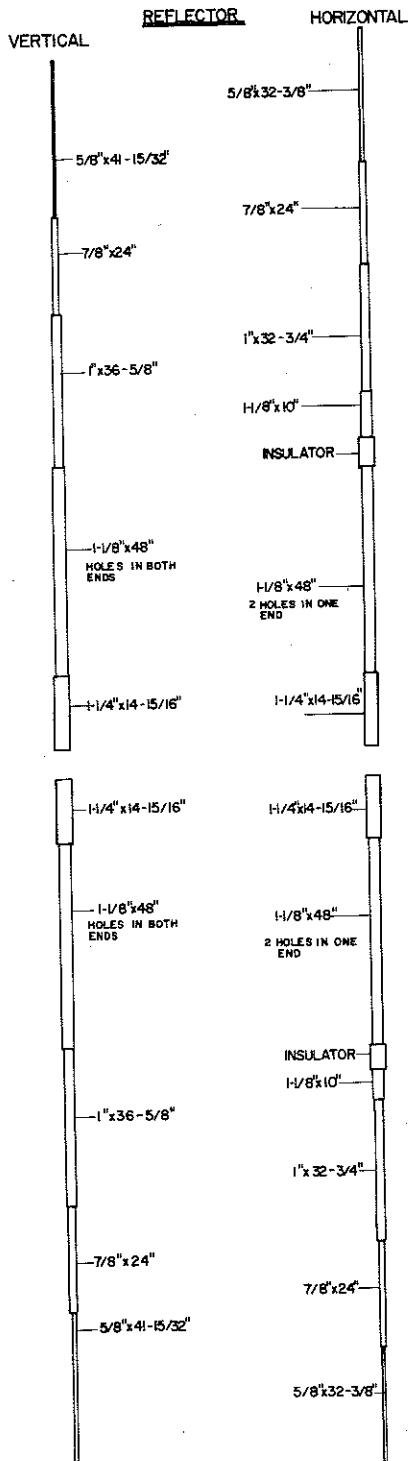

Figure 2. Reflector Horizontal and Vertical Spreader Arm Assembly

The assembly sequence will be described in the following order:

- a. Reflector Spreader Arm Assembly Horizontal
- b. Reflector Spreader Arm Assembly Vertical
- c. Driven Element Spreader Arm Assembly Top Vertical
- d. Driven Element Spreader Arm Assembly Bottom Vertical

- e. Driven Element Spreader Arm Assembly Horizontal
- f. Assembly of Spreader Arms to Boom Sections
- g. Compression Clamp Assembly
- h. Element Assembly
- i. Phone By-Pass Wires
- j. Element Tension
- k. Gamma Match Assembly
- l. Boom Assembly
- m. Final Preparations

Reflector Spreader Arm Assembly

Horizontal

() Both ends of the horizontal spreader arms are assembled in exactly the same way. For simplicity, the assembly procedures for only one end will be discussed. Refer to Figure 2.

() Insert the 1 1/8" x 48" tube into the 1 1/4" x 14 15/16" tube. Align the holes and secure the tubes using #10 x 3/8" self tapping screws.

() Select the spreader arm insulators and attach them loosely on the end of the 1 1/8" x 48" tube.

() Select the tube measuring 1 1/8" x 10" and insert it into the spreader arm insulator.

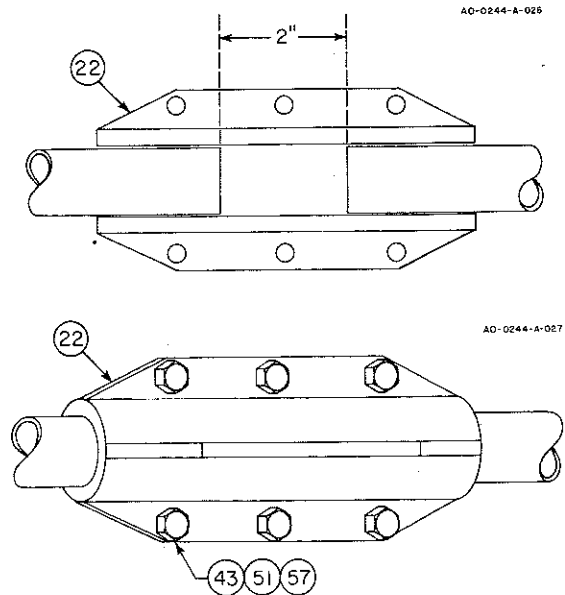

Figure 3. Horizontal Spreader Arm Insulator Assembly

CAUTION

The 10" piece of 1 1/8" tube must be inserted to a depth that allows a 2" space between it and the 48" length of 1 1/8" tube. Once this 2" spacing dimension is assured, securely tighten the insulator sections together using the 1/4" x 3/4" bolt, nut and internal lockwasher, as shown in Figure 3.

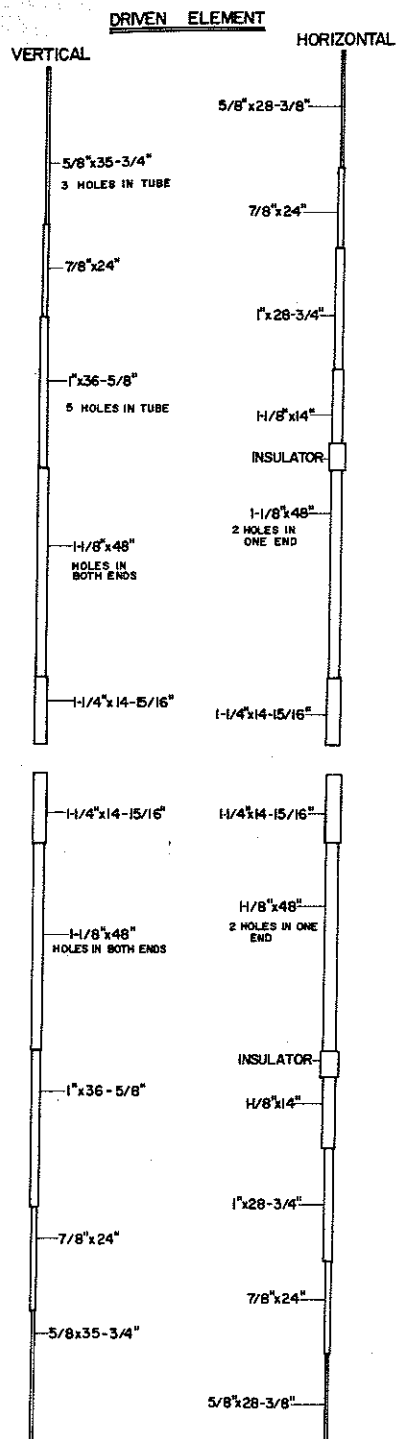

Figure 4. Driven Element Spreader Arm Assembly

() Select a 1" x 32 $\frac{3}{4}$ " tube and slip the end with the smaller drilled holes into the 10" piece of 1 $\frac{1}{8}$ " tube. Align the holes and secure using the #10 x $\frac{3}{8}$ " self tapping screws.

() Select the $\frac{7}{8}$ " x 24" tube and slip the end with smaller holes into the 1" x 32 $\frac{3}{4}$ " tube. Align the holes and secure using #10 x $\frac{3}{8}$ " self tapping screws.

() Select the $\frac{5}{8}$ " x 32 $\frac{3}{8}$ " tube and slip the drilled end into the $\frac{7}{8}$ " x 24" tube. Align the holes and secure using the #10 x $\frac{3}{8}$ " self tapping screws.

- 4 -

This concludes the assembly of half the horizontal reflector spreader arm. The other half is assembled in exactly the same way.

Vertical

() Select a 1 $\frac{1}{4}$ " x 14 $\frac{15}{16}$ " tube and a 1 $\frac{1}{8}$ " x 48" tube. Do not interchange the ends. The hole diameters are different and the small holes must be inside the large tubes. Align the holes and secure the tubes using #10 x $\frac{3}{8}$ " self tapping screws.

() Select the 1" x 36 $\frac{5}{8}$ " tubes and slip the end with the smaller drilled holes into the 1 $\frac{1}{8}$ " x 48" tubes. Align the holes and secure using #10 x $\frac{3}{8}$ " self tapping screws.

() Select the $\frac{7}{8}$ " x 24" tubes and slip the unswaged end into the 1" x 36 $\frac{5}{8}$ " tubes. Align the holes and secure with #10 x $\frac{3}{8}$ " self tapping screws.

() Select the $\frac{5}{8}$ " x 41 $\frac{15}{32}$ " tubes and slip the drilled end into the $\frac{7}{8}$ " x 24" tubes. Align the holes and secure using the #10 x $\frac{3}{8}$ " self tapping screws.

Driven Element Assembly

Top Vertical Spreader Arm

Refer to Figure 4. Select a 1 $\frac{1}{4}$ " x 14 $\frac{15}{16}$ " tube and a 1 $\frac{1}{8}$ " x 48" tube. Slip the 1 $\frac{1}{8}$ " x 48" tube into the end of the 1 $\frac{1}{4}$ " tube. Align the holes and secure using the #10 x $\frac{3}{8}$ " self tapping screws.

() Next, select the 1" x 36 $\frac{5}{8}$ " tube, which is drilled for attachment of a tombstone insulator, and insert into the 1 $\frac{1}{8}$ " x 48" tube. Align the holes and secure using #10 x $\frac{3}{8}$ " self tapping screws.

() Select the $\frac{7}{8}$ " x 24" tube and insert into the 1" x 36 $\frac{5}{8}$ " tube. Align the holes and secure using #10 x $\frac{3}{8}$ " screw.

() Next, select the $\frac{5}{8}$ " x 35 $\frac{3}{4}$ " tube, which is also drilled for attachment of the tombstone insulator, and insert into the $\frac{7}{8}$ " x 24" tube. Turn the tube so the holes line up. The hole for the tombstone insulator in this $\frac{5}{8}$ " tube must line up with the tombstone insulator hole in the 1" x 36 $\frac{5}{8}$ " tube.

() This completes assembly instructions on the top driven element assembly. This should now be marked "Top DE" and set aside for future use.

Bottom Vertical Spreader Arm

() First, select the 1 $\frac{1}{4}$ " x 14 $\frac{15}{16}$ " tube and a 1 $\frac{1}{8}$ " x 48" tube. Insert the drilled end of 1 $\frac{1}{8}$ " diameter tube into the drilled end of the 1 $\frac{1}{4}$ " diameter tube. Align the holes and secure by using the #10 x $\frac{3}{8}$ " self tapping screws.

() Select the 1" x 36 $\frac{5}{8}$ " tube and insert the drilled end into the 1 $\frac{1}{8}$ " tube. Align the holes and fasten securely, using the #10 x $\frac{3}{8}$ " self tapping screws. Align the holes and fasten securely.

() Select the $\frac{7}{8}$ " x 24" tube and insert it into the 1" x 36 $\frac{5}{8}$ " tube. Align the holes and secure using #10 x $\frac{3}{8}$ " screw.

() Finally, select the $\frac{5}{8}$ " x 35 $\frac{3}{4}$ " tube and insert in the $\frac{7}{8}$ " tube. Again, align the holes and fasten securely using the same type hardware as before.

() Mark this spreader arm assembly "Lower DE" and set aside for future use.

Horizontal Spreader Arm Assembly

The last spreader arm assembly is the horizontal arms of the driven element. These too will be assembled in halves. Both halves are identical, therefore, assembly of only one half will be described.

() Select the 1 $\frac{1}{4}$ " x 14 $\frac{15}{16}$ " tube and 1 $\frac{1}{8}$ " x 48" tube. Insert the end of the 1 $\frac{1}{8}$ " x 48" tube into the drilled end of the 1 $\frac{1}{4}$ " x 14 $\frac{15}{16}$ " tube. Align the holes and fasten securely using the #10 x $\frac{3}{8}$ " self tapping screw.

() Select the spreader arm insulators and attach loosely on the end of the 1 $\frac{1}{8}$ " x 48" tube.

() Select the tube measuring 1 $\frac{1}{8}$ " x 14" and insert into the spreader arm insulator.

CAUTION

The 14" piece of 1 $\frac{1}{8}$ " tube must be inserted to a depth leaving a 2" space between it and the 48" length of 1 $\frac{1}{8}$ " tube. Once this 2" spacing dimension is assured, securely tighten the insulator sections together, using the $\frac{1}{4}$ " x $\frac{3}{4}$ " bolt, nut and internal lockwasher, as shown in Figure 3.

() Select the 1" x 28 $\frac{3}{4}$ " tube and slip the end with the smaller holes into the 14" piece of 1 $\frac{1}{8}$ " tube. Align the holes and secure using #10 x $\frac{3}{8}$ " self tapping screws.

() Select the $\frac{7}{8}$ " x 24" tube and slip the end with the smaller drilled holes into the 1" x 28 $\frac{3}{4}$ " tube. Align the holes and secure using #10 x $\frac{3}{8}$ " self tapping screws.

() Select the $\frac{5}{8}$ " x 28 $\frac{3}{8}$ " tube and slip the drilled end into the $\frac{7}{8}$ " x 24" tube. Align the holes and secure using #10 x $\frac{3}{8}$ " self tapping screws.

() This completes the assembly of half the horizontal driven element spreader arm. The other half is assembled in exactly the same way.

Assembly of Spreader Arms To Boom Sections:

() At this point, 8 spreader arms should be properly labeled and grouped together as to Reflector or Driven Element (four in each group) as shown in Figure 5.

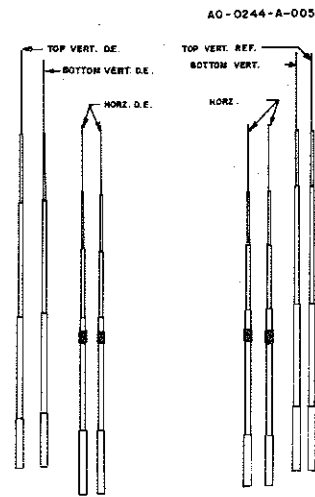

Figure 5. Spreader Arms Grouped and Labeled

NOTE: To aid in this part of the assembly, a 3" dia. x 3' length of pipe can be driven in the ground about 1 foot. This will hold each boom section in a near vertical position while the spreader arms are assembled.

() Select the eight spreader element brackets and loosely assemble using $\frac{1}{4}$ -20 x $\frac{3}{4}$ " bolts, nuts, and lockwashers, $\frac{1}{4}$ "-20 x $\frac{3}{8}$ " anchor bolts and square nuts, as shown in Figure 6.

() Select a 2" x 47 $\frac{7}{8}$ " of tubing and stick the end with the $\frac{5}{16}$ " dia. hole into the piece of 3" pipe driven in the ground previously. This is one half of the boom.

AO-0244-B-006

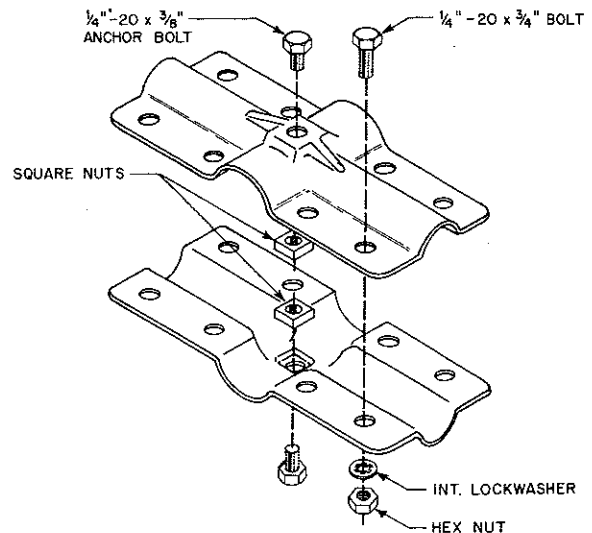

Figure 6. Boom-to-spreader Arm Assembly

() Place two pair of loosely assembled spreader element brackets in position on the end of the boom as shown in Figure 7. Place the 2" caplugs on the ends of the boom.

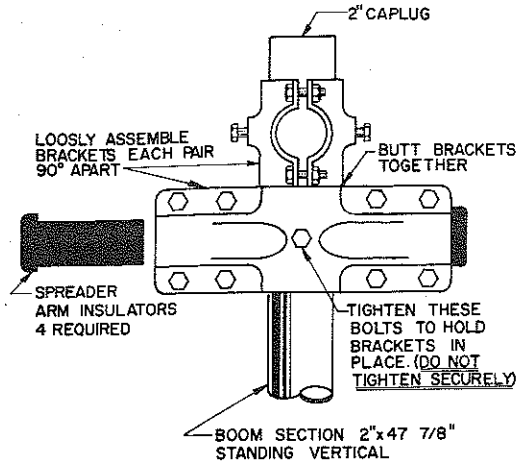

Figure 7. Boom-to-spreader Arm Bracket Assembly

() Select 4 spreader arm insulators and insert one into the end of each bracket, as shown above.

NOTE: This will be the reflector end of the boom.

() From the group of reflector spreader arms assembled earlier, take the two marked horizontal and slip them into the two spreader arm insulators in the brackets farthest from the end of the boom See Figure 8.

() From the same group, take the two spreader arms marked top and bottom reflector and insert them into the other pair of brackets assembled closest to the boom end.

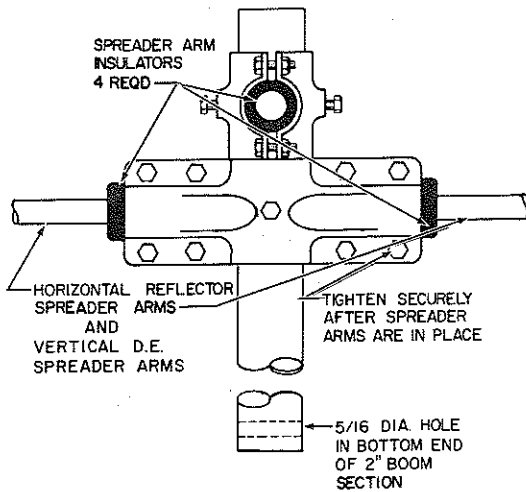

Figure 8. Boom-to-spreader Arm Bracket Assembly

NOTE: The spreader arm bracket containing the horizontal spreader arms should be parallel with the $\frac{5}{16}$ " diameter hole in the opposite end of the 2" boom tube.

() Remove this assembly from the pipe and prepare to assemble the driven element spreader arms on the other 2" x 47 $\frac{7}{8}$ " boom section.

() Select the remaining 2" x 47 $\frac{7}{8}$ " boom section and insert the drilled end into the pipe as done before.

() Select the last 2 pair of loosely assembled boom-to-spreader arm brackets and assemble them on the opposite end of the boom, as shown in Figure 7. Leave just enough room for the 2" caplug to be inserted on the end of the boom tube as shown.

() Insert the four remaining spreader arm insulators into the ends of each pair of brackets.

() From the group of driven element spreader arms, select the one marked Driven Element Top and the one marked Driven Element Bottom.

() Insert these into each end of the spreader arm insulators on the bracket farthest from the top end of the boom.

() Turn the driven element top spreader arm so that when the boom section is standing vertical the extra holes in the 1" and $\frac{5}{8}$ " tubes of this spreader arm assembly are pointing straight up.

NOTE: To avoid problems later in the assembly, be sure that all the tubes bottom out against the insulator.

() Select the two remaining spreader arms marked Driven Element Horizontal.

() Insert these into the spreader arm insulators located in the pair of brackets closest to the end cap.

() Tighten the $\frac{1}{4}$ " x $\frac{3}{4}$ " bolts securely.

() Adjust the spreader arms to 90° apart by slowly turning the boom-to-spreader arm brackets, then tightening the $\frac{1}{4}$ " x $\frac{3}{8}$ " anchor screws located on each bracket.

() This completes the driven element half of the antenna.

NOTE: Make sure the horizontal spreaders are parallel with the $\frac{5}{16}$ " diameter hole in the opposite end of the 2" boom tube.

**Compression Clamp Assembly
(See Figures 10, 11, and 12)**

Driven Element

NOTE: Compression clamps should only be hand tightened at this time.

() Slip the two 1 $\frac{1}{2}$ " compression clamps, item 28, over the ends of the horizontal element spreader tubes and assemble them in their proper position on the 1 $\frac{1}{8}$ " diameter tubes.

THIS ILLUSTRATION FOR MEASUREMENTS ONLY
REFER TO DETAILED ILLUSTRATIONS FOR ASSEMBLY. READ ALL NOTES CAREFULLY.

40-0244-C-011

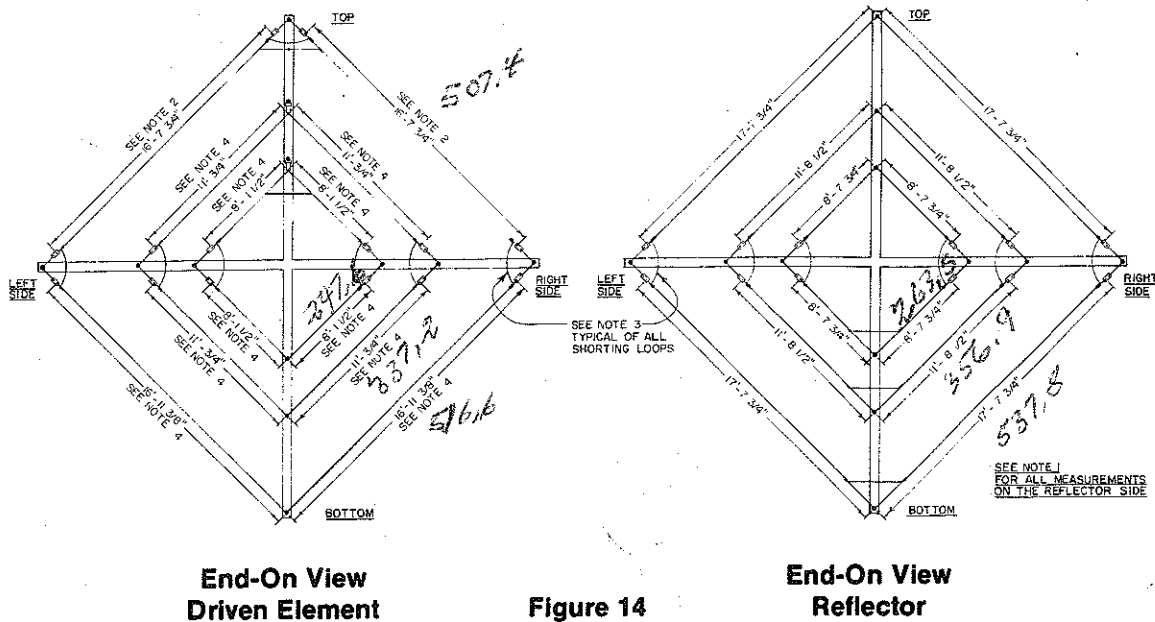

Figure 14

NOTES

1. Measurements are made from the center of compression clamps and the center of hole in insulators. Tolerances are not specific; antenna performance depends on assembly.
2. Add $2\frac{1}{2}$ to this dimension for the overall length of the wire to allow for wrapping and bypass loops.

3. Length of the loop must be maintained at 9". All other bypass wire dimensions are found in detailed assembly illustrations. Keep all dimensions accurate.
4. Add $1\frac{1}{2}$ to this dimension for overall length of wire to allow for wrapping and bypass loop.

Figure 14. Measurements For Antenna Stringing

IMPORTANT

The most difficult part of the antenna assembly is the stringing of the element wire. Take extra time to plan the remaining steps. Figure 14 gives the lengths and spacings of the elements. With these measurements and a thorough study of the antenna, there should be minimal problems.

General Assembly Outline

The general outline of steps is listed below. Follow the detailed instructions for assembly.

1. Attach all insulators to the compression clamp screws.
2. String the element wires.
3. Attach all jumper wires, i.e. phone bypass, driven element bypass etc. as shown in the detailed drawings Figure 16 through Figure 34.

NOTE: Dimensions of jumper wires are critical. All measurements must be accurate.

The element wire shrinks in cold weather, **DO NOT** overtighten it during assembly.

NOTE: To prevent tangling do not cut all wire ties holding the large roll of wire. Improvise a spool or some other means of containment and pull off only as much wire as needed or each piece. Do not use pliers to pull or wrap the wire. Any nicks weaken the wire.

Detailed Assembly Instructions

() Mount the element insulator hangers, item 68, on the element tubes. The locations for the driven element spreader arms are noted in Figure 15. Their typical mounting is shown in Figure 16, 17, 21, 22, and 23. Refer to Figure 34 for more detail.

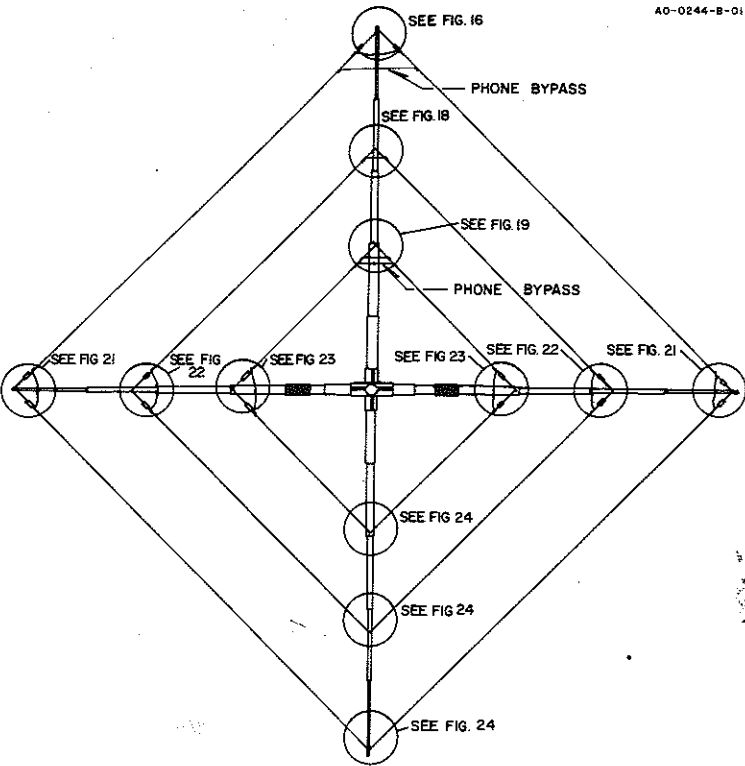

Figure 15. Driven Element Assembled

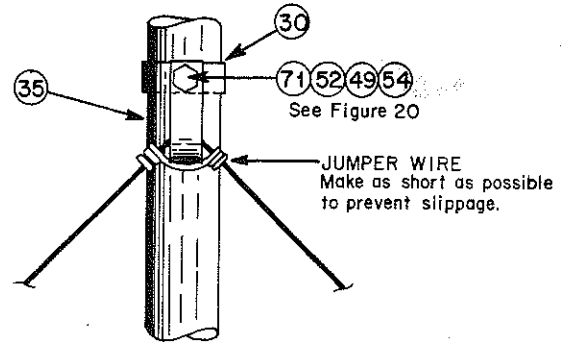

Figure 18. Assembling Insulator on Top DE Spreader Arm at 15 Meter Location

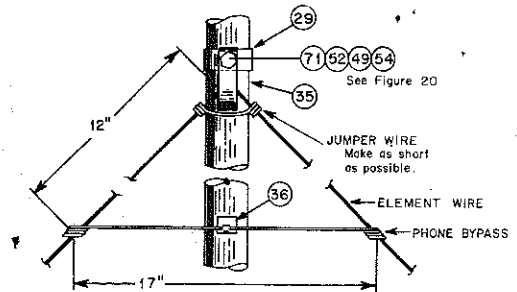

Figure 19. Assembling Insulator on Top DE Spreader Arm at 10 Meter Location

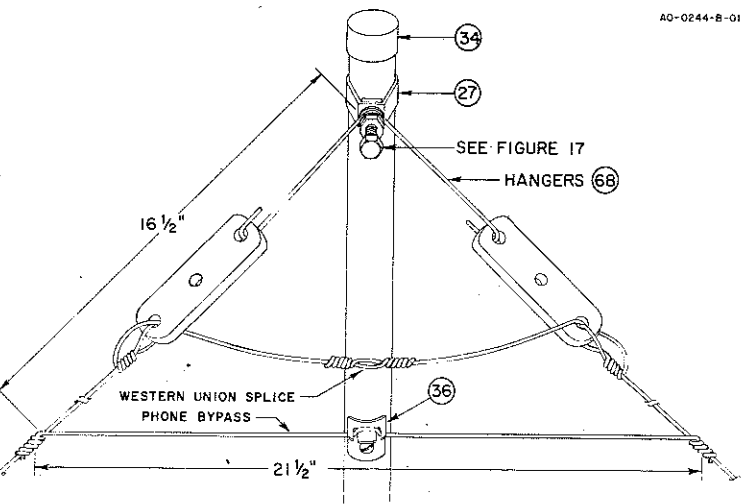

Figure 16. 20 Meter Connection to Top Spreader Arm of Driven Element

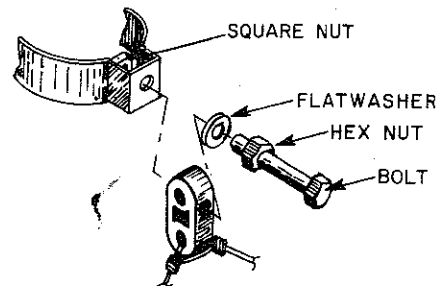

Figure 20. Hardware Details for Figures 18 and 19

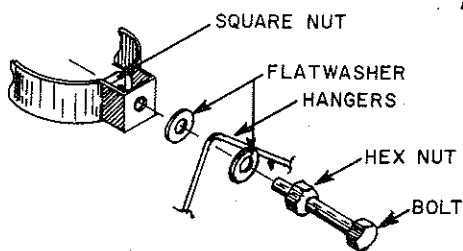

Figure 17. Install Insulators Hangers on Driven Element Spreader Arms

() Squeeze the hanger ends together so the insulators won't come off.

() Assemble the ten and fifteen meter driven element upper insulators as shown in Figure 18, 19 and 20, and attach to the top driven element spreader arm.

() Fasten the compression clamps securely at the dimensions shown in Figure 13.

() Install the six 1/16" compression clamps, item 29. Slip three of them over the bottom vertical driven element spreader arm as shown in Figure 9. Slip one over the top end of the vertical spreader arm as shown and slip one over each end of the driven element horizontal spreader arm as shown in Figure 9.

() For proper assembly of the middle 1" compression clamp on the middle of the bottom driven element tube, refer to Figure 24, Gamma Match Detail.

() Select two 7/8" compression clamps, item 30, and slip one on the end of each vertical driven element spreader arm and loosely attach them on the 7/8" tubing at the dimensions called for in Figure 9.

() Next, select five of the 1 1/16" compression clamps and place them on each spreader arm at the locations shown in Figure 9.

NOTE: The 5/8" tube of the bottom vertical driven element spreader arm takes two 1 1/16" compression clamps as shown.

() This completes the basic assembly of the compression clamps on the driven element half of the antenna. Remove this half from the pipe and lay it to one side.

() Insert the reflector half of the antenna in the pipe and prepare to assemble the compression clamps as shown in Figure 13.

() Select seven 1" compression clamps and hardware. Slip two clamps on each end of the horizontal reflector spreader arms, two clamps on the bottom vertical reflector spreader arms and one clamp on the top vertical reflector spreader arm.

() Loosely assemble these clamps at the location given in Figure 13.

() Select three 7/8" compression clamps and hardware. Slip two clamps over the bottom vertical reflector spreader arms and one clamp over the top vertical reflector spreader arm.

() Move them to the proper dimensions shown in Figure 13 and fasten loosely.

() Select five 1 1/16" compression clamps and hardware and slip two clamps on the end of the bottom vertical reflector spreader arm as shown in Figure 13.

() Slip one clamp on each of the other reflector spreader arms. Fasten all five compression clamps loosely at the locations shown in Figure 13.

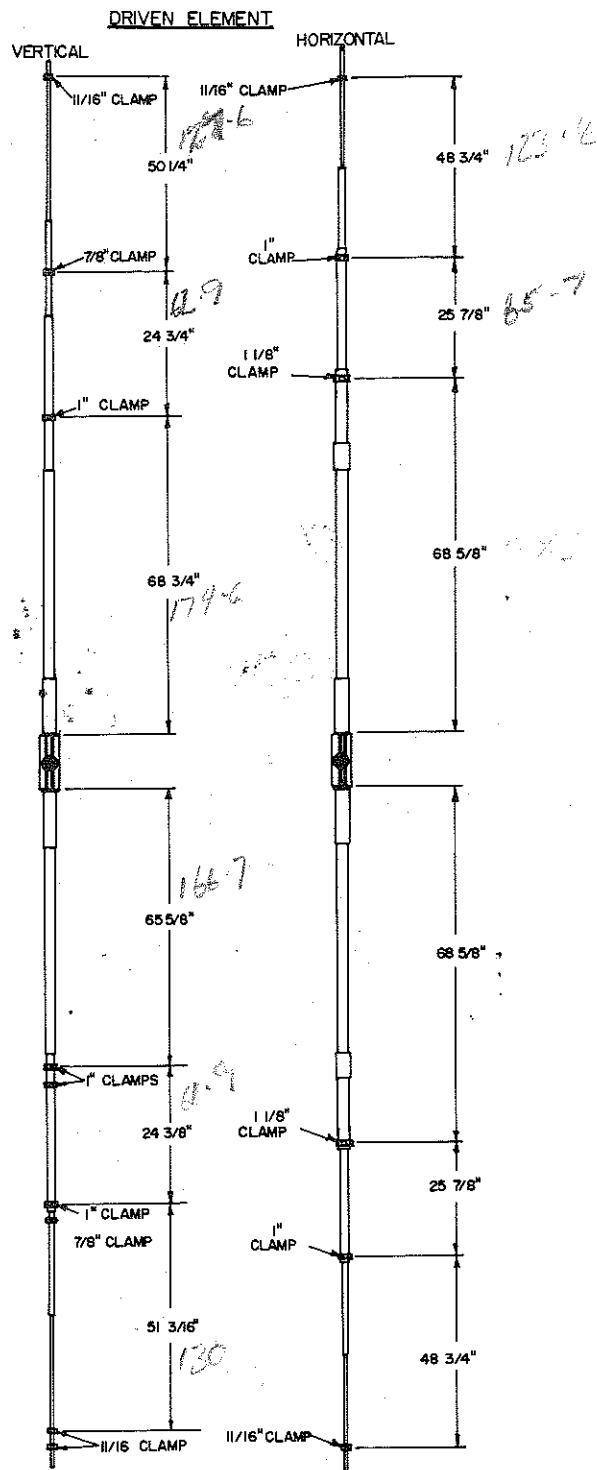

Figure 9. Driven Element Compression Clamp Assembly

AO-0244-A-010

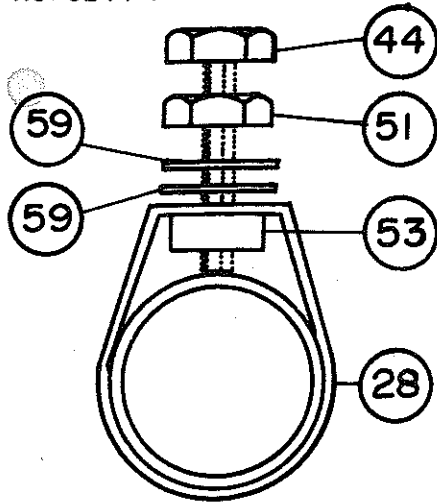

Figure 10. 1 1/8" Compression Clamp

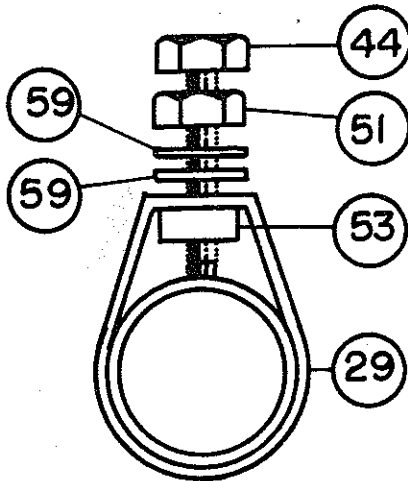

Figure 11. 1" Compression Clamp

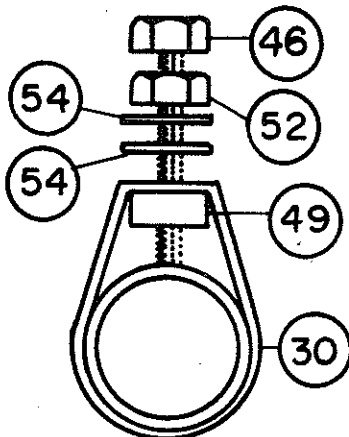

Figure 12. 7/8" Compression Clamp

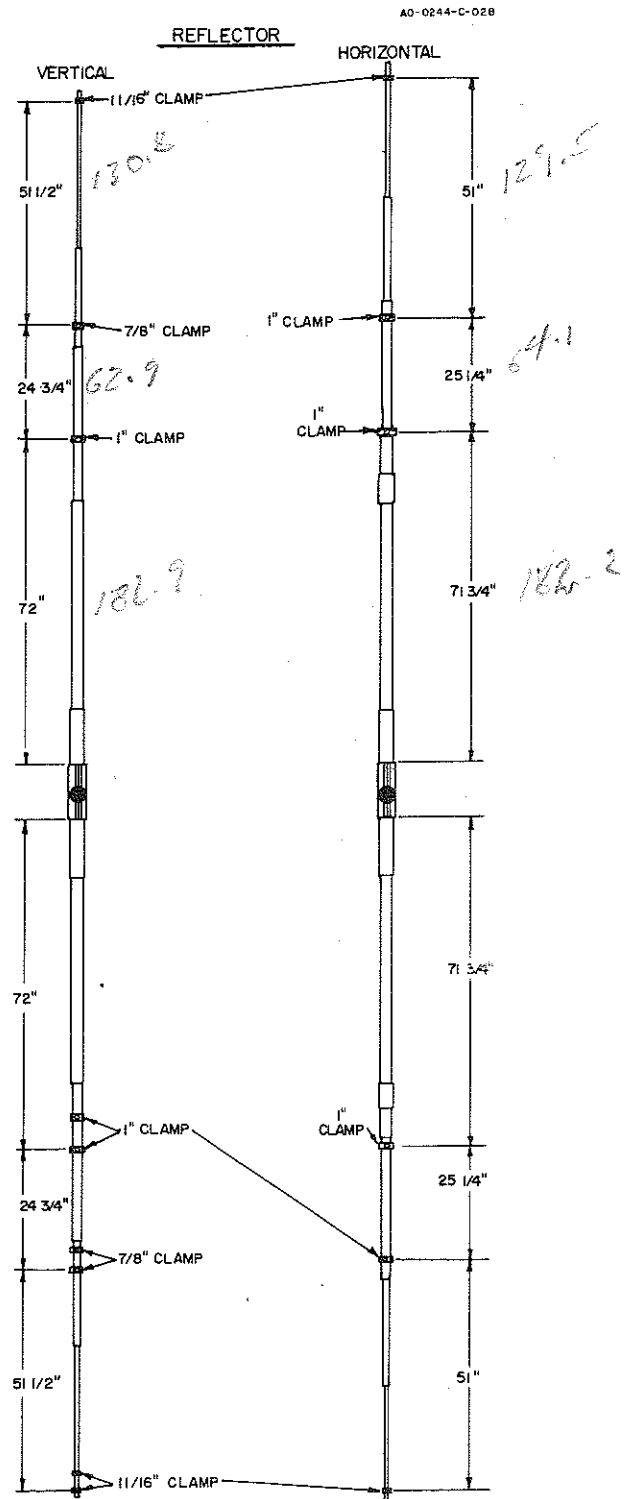

Figure 13. Reflector Compression Clamp Assembly

NOTE: These figures are only to be used for proper assembly of the hangers and insulators on the various compression clamps and should not be used at this time for attaching element wire. This phase of assembly will be explained later.

() Refer to Figure 24 for attaching hardware to the bottom driven element spreader arm.

Stringing Element Wire

() Cut two lengths of wire to the dimensions given in Figure 14. String them individually from the left spreader arm through the insulators on the top spreader arm, and down to the right spreader arm.

NOTE: Cut the wires 2'-6" longer than specified to allow for loops and wrapping at each end but mark the specified lengths with tape.

() All remaining wires on the driven element can be strung in halves. This is done by adding the dimensions together, cutting the wire and then stringing. Example: Driven Element, 10 Meter. Combining the two dimensions shown in Figure 14 (left spreader-to-top spreader and right spreader-to-top spreader) you have 16' 3". Add 2' 6" to this dimension for excess to be used for the loops and wrapping at each end.

() Beginning with the 20 meter wire on the left spreader insulator, Figure 21, wrap and tie the wire through the insulator leaving enough wire for splicing. The loop length with splice must be 9". Run the wire through the insulator on the top spreader arm, Figure 16, and connect it to the insulator on the right spreader arm as shown in Figure 21, only reversed. Your lengths must correspond to the dimensions shown in Figure 14.

() Use the same procedure on the bottom half of the 10 Meter driven element wire and splice the two halves together with a Western Union Splice (Figure 21), making sure the splicing loop length is 9". Clip off all excess wire when the antenna is completely strung. Use this procedure at all the remaining points within the antenna.

() Connect the fifteen meter wire on the driven element spreader arms as shown in Figures 18, 22 and 24. The jumper wire in Figure 18 presents wire slippage, tie it as short as possible.

() Connect the ten meter wire on the driven element spreader arms as shown in Figure 19, 23 and 24. Refer to these figures and Figure 14 for aid in this part of the assembly. The jumper wire in Figure 19 presents wire slippage — tie it as short as possible.

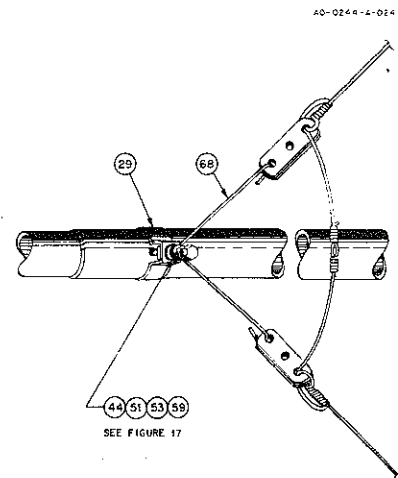

Figure 22. Horizontal DE Spreader Arm-to-Element Connection

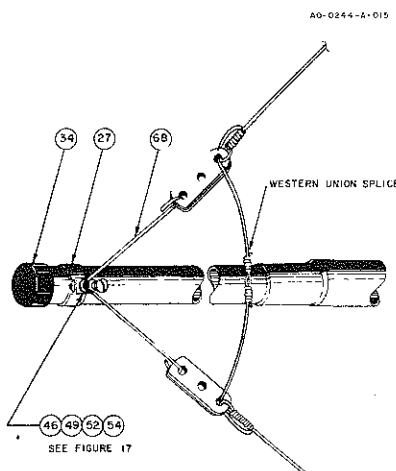

Figure 21. Horizontal DE Spreader Arm-to-Element Connection

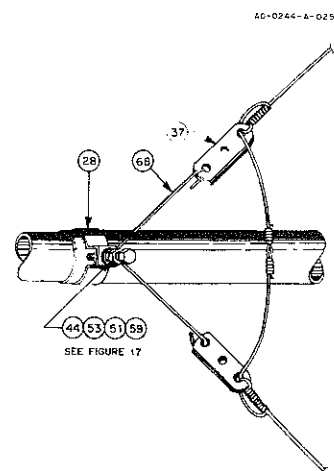
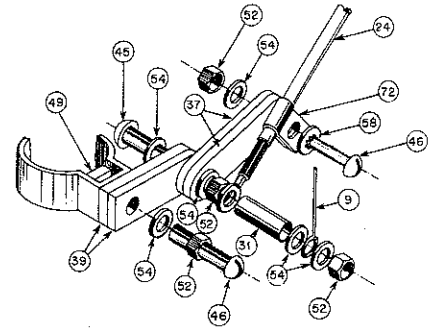
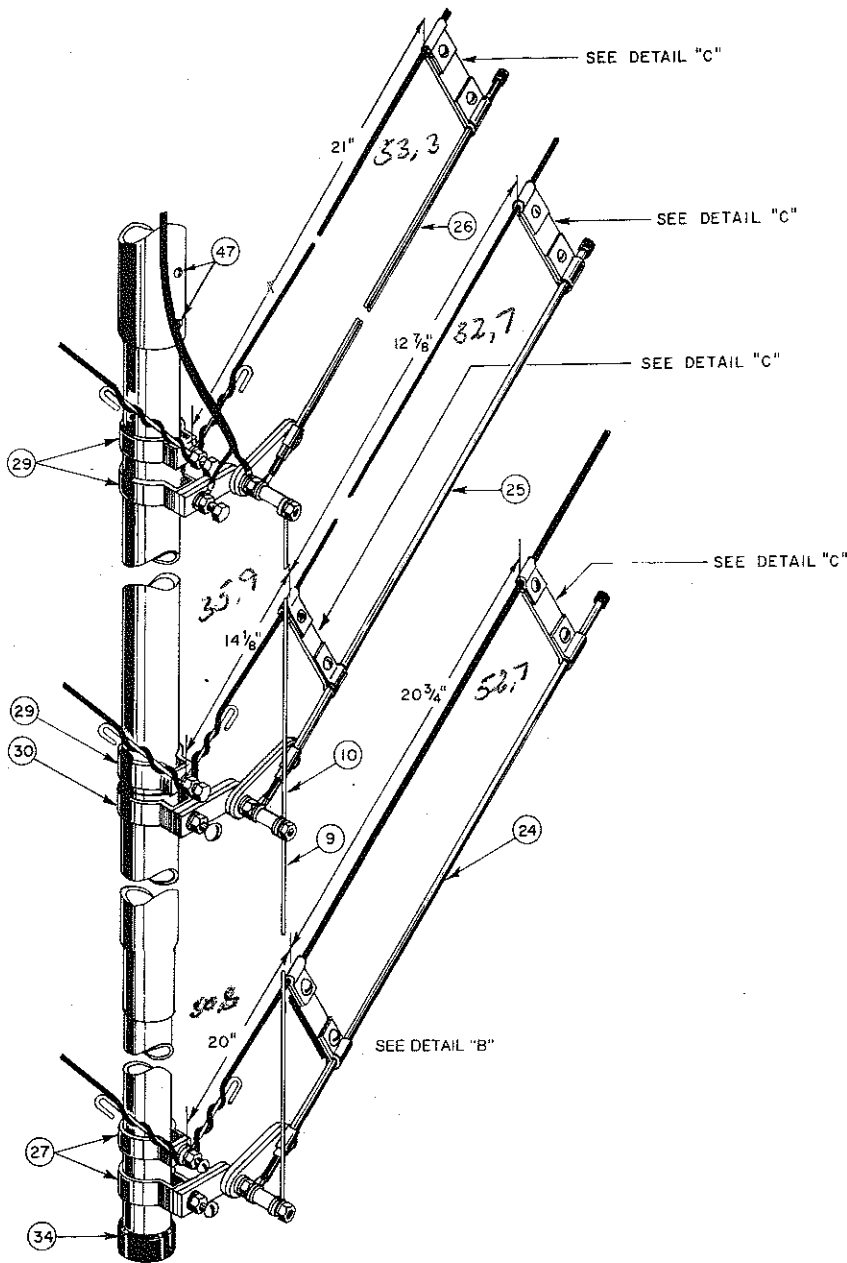
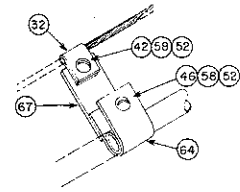

Figure 23. Horizontal DE Spreader Arm-to-Element Connection



Detail "A"

This arrangement of clamp and insulator is used only at this point on 20 meter gamma match; for support only.



Detail "B"

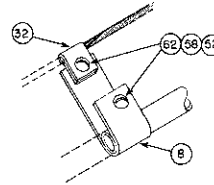

Detail "C"

NOTES

1. Same general arrangement as in Detail "A".
2. Use a flat washer on each side of wire.
3. Center conductor of coax connects to 10 meter gamma match, braid connects to compression clamp screws.

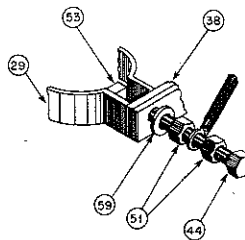

Detail "D"

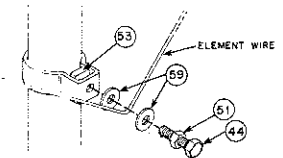

Detail "E"

Figure 24. Gamma Match Assembly and Bottom Driven Element Details

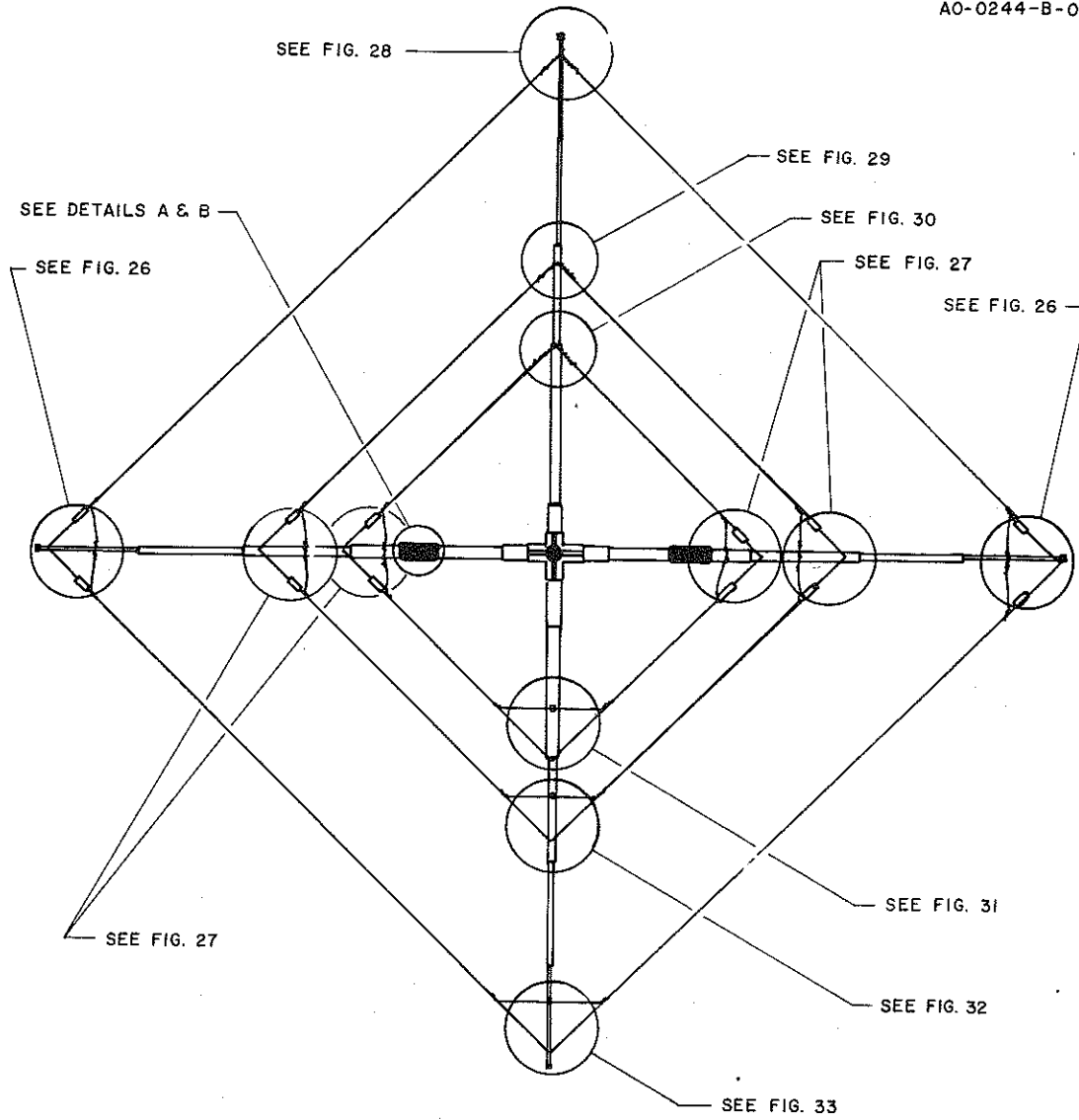

Figure 25. Reflector Element Assembled

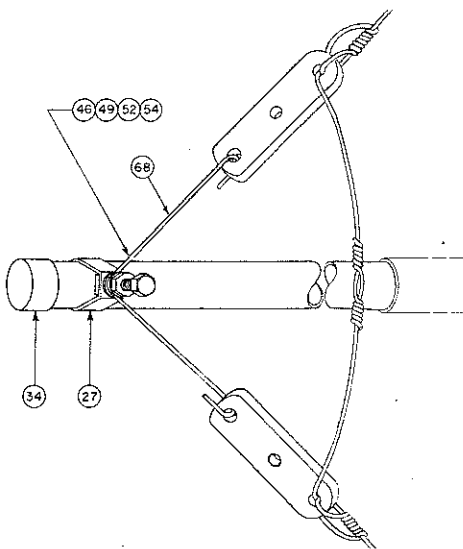

Figure 26. Horizontal Reflector Element Connection 20 Meter

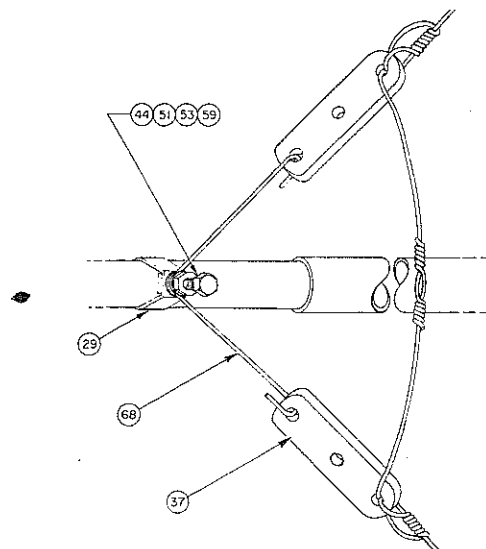
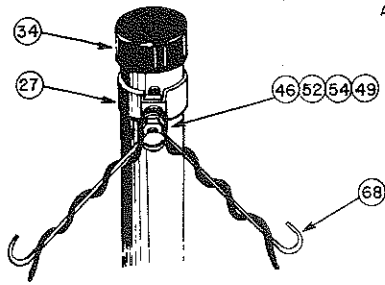
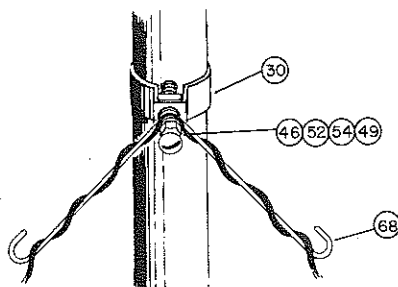

Figure 27. Horizontal Reflector Element Connection 10 & 15 Meter



AO-0244-A-018

Figure 28. Top Reflector Spreader Arm to Element Connection 20 Meter



AO-0244-A-038

Figure 29. Top Reflector Spreader Arm to Element Connection 15 Meter

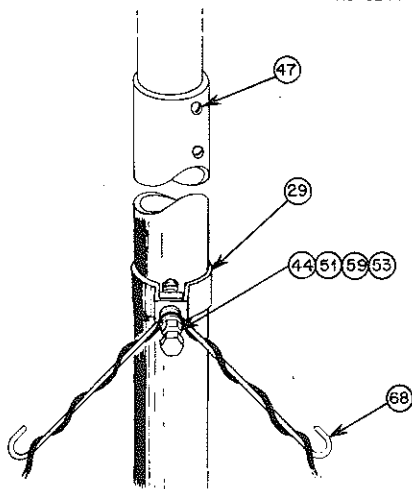

AO-0244-A-039

Figure 30. Top Reflector Spreader Arm to Element Connection 10 Meter

Stringing the Element Wire on the Reflector Spreader Arms

NOTE: When stringing the wires, do not wrap the wire around the compression clamp screws. Pass the wires by the screws and wrap around the hanger. Remember the wire wrapped on the hanger is shorted out.

() Refer to Figure 25 for a general diagram of how wire should look on the reflector half of the antenna.

() Cut the wire as was done with the driven element. Use Figure 14 as a guide. Double the dimension and add 2' 6". Cut the wire. When stringing and attaching the 20 meter element wire, refer to Figures 26, 28, and 33. Note that Figure 26 shows the left horizontal spreader arm attachment. The right horizontal spreader arm attaches to the element wire the same as the left. Therefore, Figure 26 will be used as a guide for both horizontal connections of the 20 meter wire.

() The 15 meter wire should be cut by referring to Figure 14 for the dimensions, then doubling the length, add 2' 6" for loops and splices, and cut.

() Refer to Figures 27 and 29 for connecting the top half of the 15 meter wire.

() Refer to Figures 27 and 32 for connecting the bottom half of the 15 meter wire. Again, the left and right horizontal connections are identical as shown in Figure 27, and referred to the Figure 25. The loop length with splice must be 9", as shown in Figure 34.

() Connect the wires using a Western Union splice, as done before. The lengths must correspond to the dimensions shown in Figure 14.

() Refer to Figures 27 and 30 for connecting the top half of the 10 meter wire to the reflector spreader arms.

() Figure 27 and 31 give detailed instructions as to the proper connection of the bottom half of the spreader arms to 10 meter element wire.

() Connect the ends with the Western Union splice. Keep the 9" loop dimension accurate. Refer to Figure 34.

Phone By-Pass Wires

For operation on the phone frequencies, the phone by-pass wires should be installed exactly as shown in Figures 16 and 19 and in Figures 31, 32 and 33.

Element Tension

() Driven Element: Tension the driven element by loosening the compression clamps on the top, right and left spreader arms and moving the clamps out toward the ends of the arms.

() Tension and remove the kinks from the wires, but do not over tension them. There should be some slack in the wire to prevent the spreader arms from bowing.

() Reflector: Tension the reflector by loosening the compression clamp screws on the top and bottom spreader arms and moving the clamps out toward the ends of the arms. The wire should not be wrapped around these screws. Pull the wires taut, move the clamps out, secure the clamp and tighten the nuts.

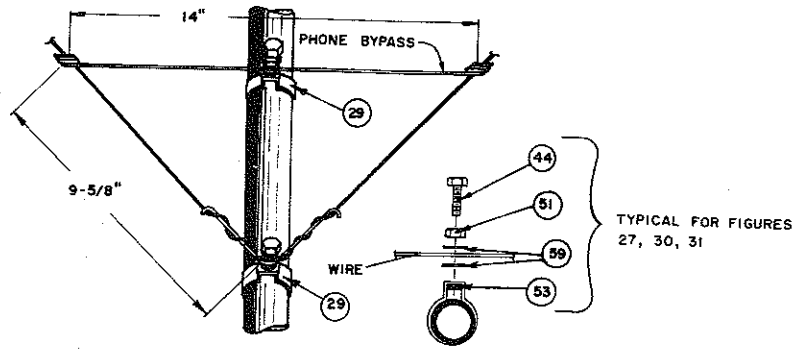

Figure 31. 10 Meter Wire Connection to Bottom Reflector Spreader Arm

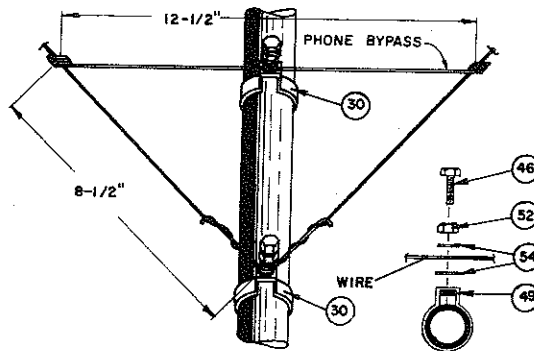

Figure 32. 15 Meter Wire Connection to Bottom Reflector Spreader Arm

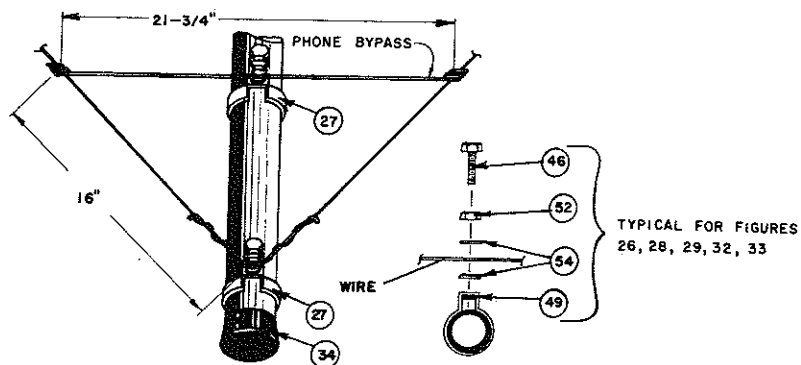

Figure 33. 20 Meter Wire Connection to Bottom Reflector Spreader Arm

() Moving the compression clamps out on the spreader arms will create an error when compared to the dimensions in Figures 9 and 13. These are approximate positioning dimensions and may not meet at the end of the antenna assembly. The critical dimensions are the lengths of the element loops, as shown in Figure 14.

() Upon completion of the assembly, each leg of the antenna loop should be accurate to within $\pm\frac{1}{4}$ " (Figure 14) and $\frac{1}{2}$ of the element loop should be within $\pm\frac{1}{2}$ ". Example: 10 Meter, Driven Element. Each dimensions of 8' 1 $\frac{1}{2}$ " to within $\pm\frac{1}{4}$ " and 16' 3" to within $\pm\frac{1}{2}$ ".

NOTE: If you want best performance for the phone sections of the amateur bands, the element by-pass wires should be installed now. See the detailed illustrations.

Gamma Match Assembly

() Select the gamma match clamps and hardware and install them on the gamma matches. See Figure 24.

() Attach the gamma matches to the element wires. When you have the correct spacings on the gamma spacing clamps, crimp the clips to the element wires to insure a good electrical connection. The wire clips should be snug but not too tight or the element wires may be cut.

() Select the two gamma rods (9, 10) and install on the gamma match insulators.

AO-0244-B-022

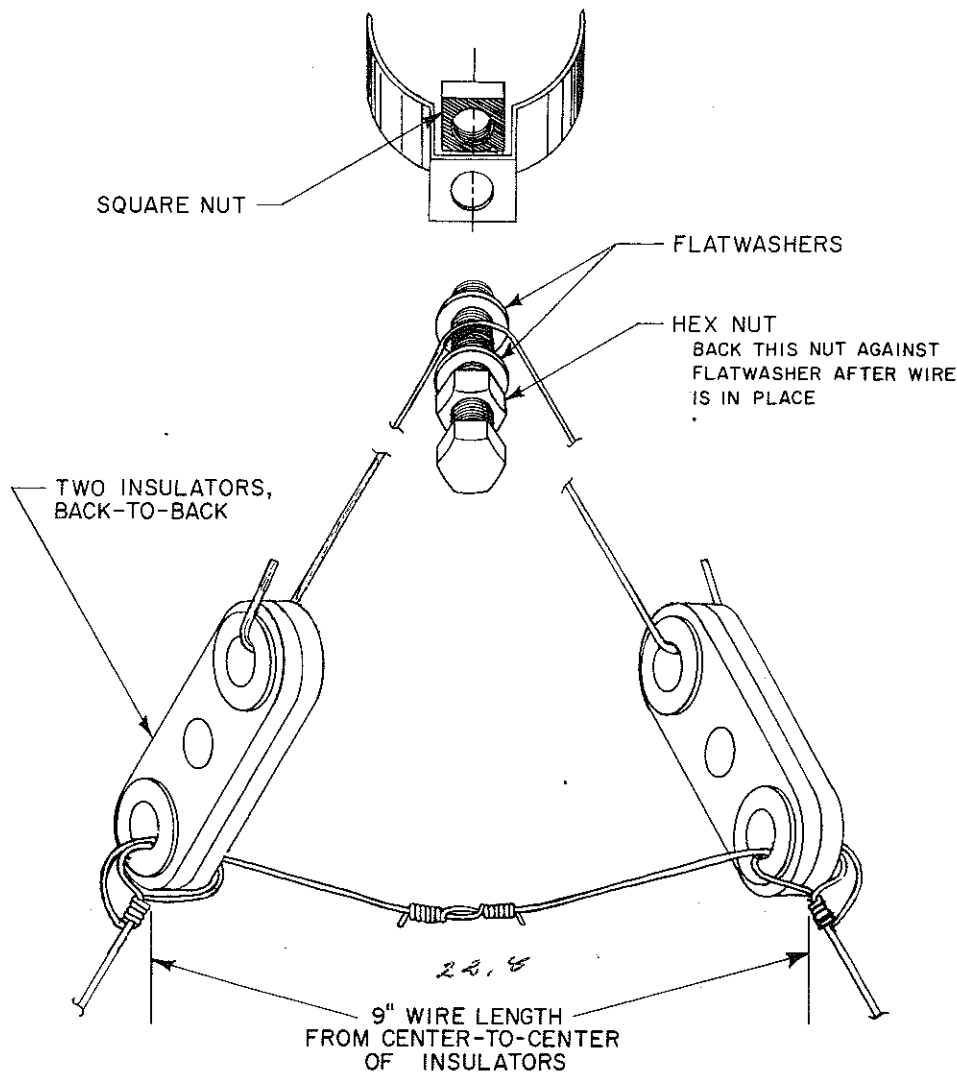

Typical of Figures 16, 21, 22, 23, 26, & 27. Unless Otherwise Specified.
Figure 34. Element Loop Details

Assembly of the Boom

() Select the cast aluminum brackets, boom-to-bracket clamp, and the casting-to-boom bracket and assemble loosely.

() Select the two boom sections and slip the drilled end into the boom-to-mast bracket. Line up the holes. Attach the boom sections to the brackets using the two $\frac{5}{16}$ "-18 x $2\frac{1}{2}$ " bolts, nuts and lockwasher provided. Do not tighten them now. The bracket must be loose to facilitate mounting the antenna on the mast.

A0-0244-B-023

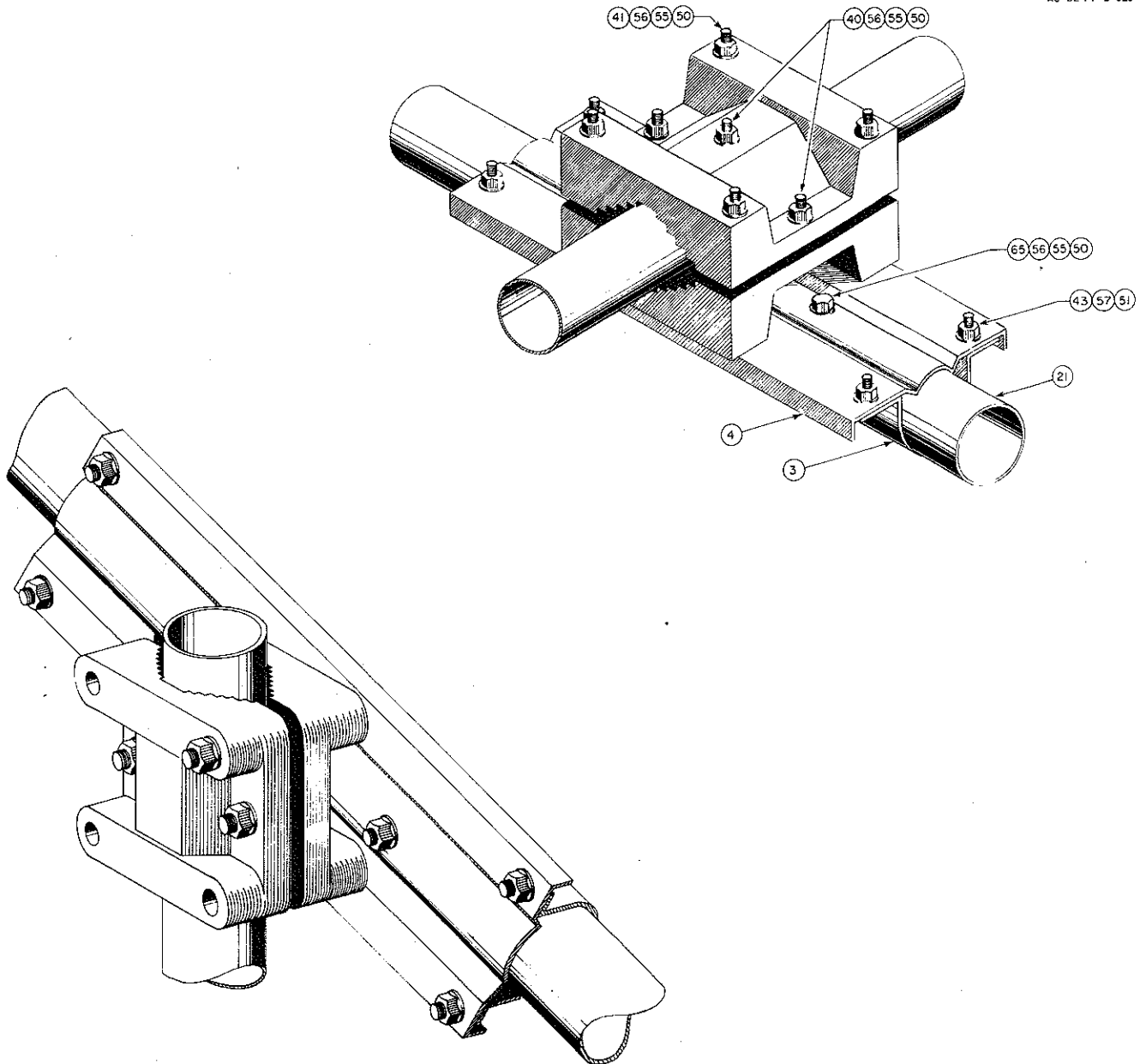

TILT HEAD BOOM-TO-MAST BRACKET

Figure 35. Boom-to-Mast Bracket

Final Preparations

() There are two styles of $\frac{5}{8}$ " caplugs. Insert these caplugs on the end of each stringer element now. The caplugs with the holes in the end must be placed on the stringer element that points down when the antenna is in its erected position. This insures proper drainage of any moisture that may accumulate in these tubes. The two inch caplugs can now be inserted on the ends of the boom.

() Run the coax feedline up the mast, across the boom, down the driven element spreader arm and attach to the 10 meter (top connection) gamma match as shown in Figure 24.

() Recheck all mechanical connections for tightness. Seal the coax connections with Dow Corning silicone rubber (Silastic), GE RTV compound, or some similar substance.

Parts List

Item	Part No.	Description	Qty	Item	Part No.	Description	Qty
1	102734	bracket, cast aluminum	2	35	471655	insulator, element to spreader arm	2
2	165920	bracket, spreader arm-to-boom #14	8	36	463642	rod support insulator, tombstone	2
3	172732	clamp, boom-to-bracket	1	37	465410	insulator, element to spreader arm	58
4	172735	bracket, casting-to-boom	1	38	471549	insulator, gamma to spreader arm	4
5	175746	element tubing, DE3-V (top only), 1" x 36 $\frac{3}{4}$ "	1	39	471552	insulator, gamma to spreader arm	2
6	175619	element tubing, DE5-V (top only), $\frac{5}{8}$ " x 35 $\frac{3}{4}$ "	1	40	501541	screw, 5/16 18 x 3 $\frac{1}{2}$ "	3
7	175781	element tubing R2-H; DE2-H, 1 $\frac{1}{8}$ " x 48" 2 holes on one end	4	41	501543	screw, 5/16 18 x 5"	4
8	175800	clamp, gamma space	4	42	506480	screw, 10-24 x $\frac{5}{8}$ "	1
9	175802	gamma rod, 15-20	1	43	506325	screw, $\frac{1}{4}$ "-20 x $\frac{3}{4}$ "	60
10	175804	gamma rod, 10-15	1	44	506389	screw, $\frac{1}{4}$ "-20 x 1"	15
11	175806	element tubing, R1-V, R1-H, DE1-V & DE1-H, 1 $\frac{1}{4}$ " x 14 15/16"	8	45	506430	screw, 10-24 x 2 $\frac{1}{2}$ "	3
12	175807	element tubing, R2-V & DE2-V, 1 $\frac{1}{8}$ " x 48" holes on both ends	4	46	506455	screw, 10-24 x 1"	17
13	175808	element tubing, R3-H, 1 $\frac{1}{8}$ " x 10"	2	47	519205	screw, type A, 10 x $\frac{3}{8}$ "	66
14	175809	element tubing, R4-H, 1" x 32 $\frac{3}{4}$ "	2	48	505540	screw, $\frac{1}{4}$ "-20 x $\frac{3}{8}$ "	8
15	175810	element tubing, R3-V & DE3-V, 1" x 36 $\frac{3}{4}$ "	3	49	555362	nut, 10-24 square	16
16	175811	element tubing, R4-V, R5-H, DE4-V & DE5-H $\frac{7}{8}$ " x 24"	8	50	556945	nut, 5/16"-18 hex	9
17	175812	element tubing, DE5-V, $\frac{5}{8}$ " x 35 $\frac{3}{4}$ "	1	51	556960	nut, $\frac{1}{4}$ "-20 hex	77
18	175813	element tubing DE6-H, $\frac{5}{8}$ " x 28 $\frac{3}{4}$ "	2	52	556970	nut, 10-24 hex	33
19	175826	element tubing, R6-H, $\frac{5}{8}$ " x 32 $\frac{3}{4}$ "	2	53	558685	nut, $\frac{1}{4}$ "-20 square	25
20	175830	element tubing, R5-V, $\frac{5}{8}$ " x 41-15/32"	2	54	567130	washer, #10 flat	45
21	175833	boom tubing, 2" x 47 $\frac{1}{2}$ "	2	55	567080	lockwasher, 5/16" split	9
22	465475	insulator, spreader arm	8	56	567085	washer, 5/16" flat	9
23	465833	insulator, spreader arm	8	57	567110	lockwasher, $\frac{1}{4}$ " internal	80
	875551	parts pack	1	58	567125	lockwasher, #10 internal	26
24	875552	gamma match, 20M	1	59	567120	washer, $\frac{1}{4}$ " flat	35
25	875553	gamma match, 15M	1	60	677555	lug 12-10 wire $\frac{1}{4}$ ring	1
26	875554	gamma match, 10M	1	61	678922	lug 12-10 wire #10 ring	1
27	165763	compression clamp, 11/16"	10	62	506485	screw, 10-24 x $\frac{1}{2}$ "	8
28	168681	compression clamp, 1 $\frac{1}{8}$ "	2	63	476488	caplug, $\frac{5}{8}$ " whole	2
29	168682	compression clamp, 1"	13	64	163307	clamp, $\frac{3}{8}$ "	1
30	168683	compression clamp, $\frac{7}{8}$ "	5	65	509173	screw, 5/16"-18 x 2 $\frac{1}{2}$ "	2
31	175805	spacer tube	3	66	691529	element wire, 360'	1
32	175514	connector, gamma match	5	67	465415	insulator, 20 meter gamma match	1
33	455625	caplug, 2"	2	68	155467	hanger	22
34	455650	caplug, $\frac{5}{8}$ "	6	71	506445	screw, 10-24 x 1 $\frac{1}{2}$ "	2
				72	175473	clamp, $\frac{3}{8}$ " ID	3
					875145	spare parts pack	1
				69	170043	element tubing, DE3-H, 1 $\frac{1}{8}$ " x 14"	2
				70	170045	element tubing, DE4-H, 1" x 28 $\frac{3}{4}$ "	2

90-DAY LIMITED WARRANTY

Hy-Gain Electronics Corporation warrants each new product manufactured to be free from defects in material and workmanship and agrees to remedy any such defect or to furnish a new part in exchange for any part of any unit which under normal installation, use, and service, discloses such defect within the ninety-day term of this warranty, dated from the date of purchase by the original owner. This warranty applies only to the original purchaser.

This warranty does not extend to any of our products which have been subjected to misuse, neglect, accident, incorrect wiring not our own, improper installation, or to use in violation of instructions furnished by us. Nor does it extend to units which have been repaired or altered outside of our factory, nor to accessories used therewith not of our own manufacture.

Upon receipt of equipment, the purchaser is responsible for checking the contents for damage. Any shipping damage should be referred to the carrier.

Hy-Gain Electronics Corporation reserves the right to make any changes deemed necessary or desirable without advance notice or incurring any obligation to make like changes in units previously manufactured or sold.

This warranty does not cover transportation costs that may be incurred. Hy-Gain Electronics Corporation's sole liability is the remedy of any defect for the ninety-day period of this warranty. Hy-Gain Electronics Corporation is not responsible for

personal injury or property damage resulting from improper or careless installation, or usage not intended by the manufacturer.

No person is authorized to assume for us any other liability in connection with the sale of our products.

All warranties are void and terminated one year after the last unit of its type and design has been manufactured by us.

All claims of defect or shortage should be addressed to:

Hy Gain Warranty Service
Hy-Gain Electronics Corporation
4900 Superior Ave.
Lincoln, Nebraska 68504

You must furnish model number, date, place, and proof of purchase, such as a copy of the sales receipt to establish warranty. Your letter should include all pertinent details along with part or item numbers involved. Do not return anything until requested to do so. No warranty card is furnished; you must supply the above information.

Any returned items must have prior authorization. Unexpected returns are greatly delayed in handling. These delays can be avoided by writing in advance and furnishing the necessary information.

HY-GAIN ELECTRONICS CORPORATION

8601 NE Highway 6, Lincoln, Nebraska 68507
402-464-9151 Telex 48-6424