

hy-gain®

LP-1009A / LP-1009AN

Log Periodic Antenna

Instruction Manual

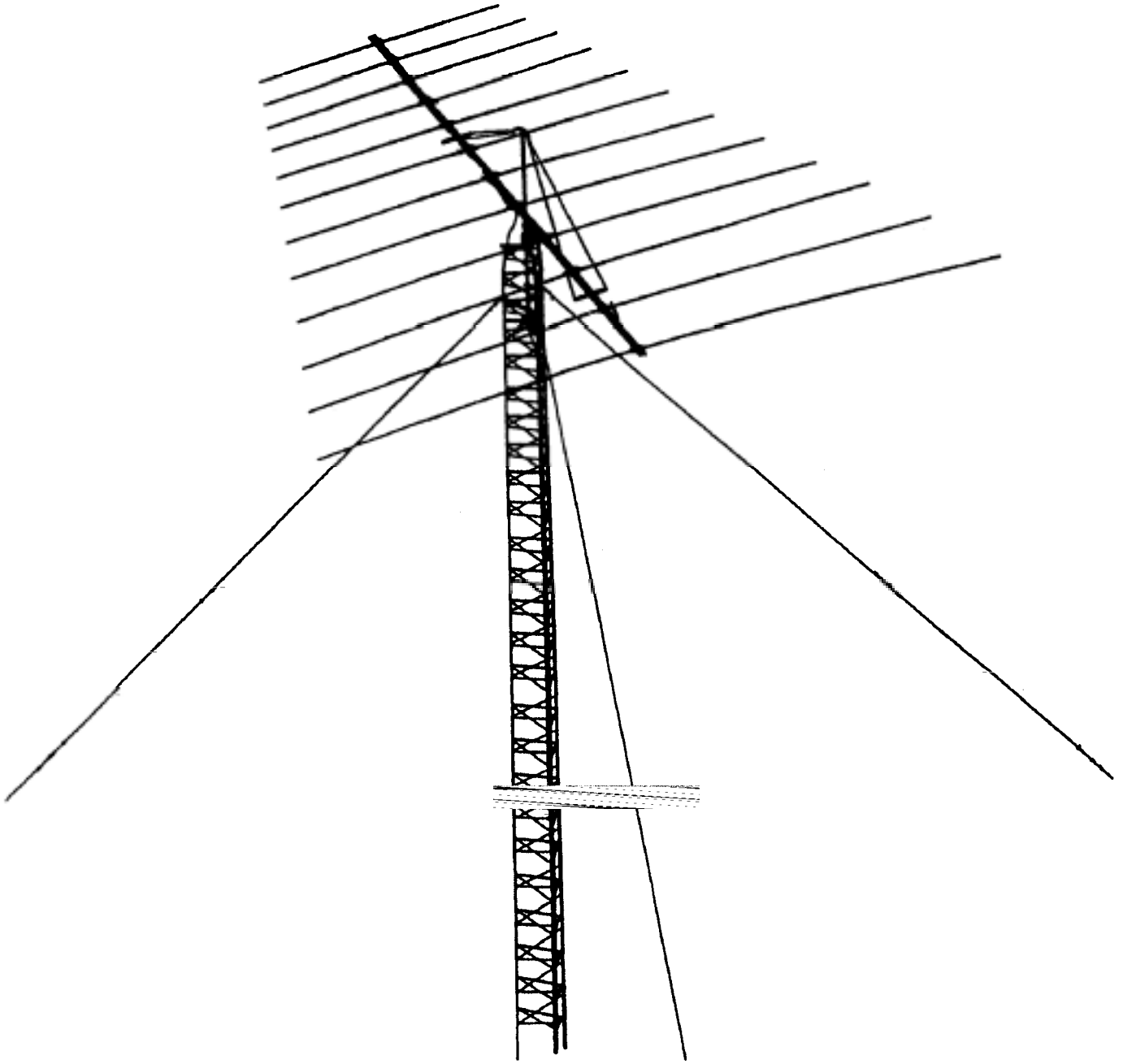

TABLE OF CONTENTS

Page CHAPTER 1

General Information	1-1
General Description	1-1
Theory of Operation.....	1-2
Preparation for Assembly.....	1-2
Installation Planning	1-3
Corrosion Precautions.....	1-3
Assembly of the Element-to-Boom Brackets on the Boom.....	1-5
Installation of Tubing Clamps on Elements.....	1-6
Element Assembly	1-8
Feedline Assembly.....	1-9
Beta Tube Assembly	1-12
Installing Elements on the Boom.....	1-15
Balun Assembly.....	1-15
Boom Support Assembly.....	1-16
Final Inspection.....	1-17

CHAPTER 2

Antenna Installation.....	2-1
Installation on a Crank-Up Tower.....	2-1
Installation on Guyed Towers.....	2-1
Attachment of Coaxial Feedline.....	2-1
Attaching the Antenna to the Mast.....	2-2
Lightning Protection	2-2
VSWR Curves.....	2-3
Operation.....	2-4
VSWR Record	2-4
Troubleshooting	2-5

LIST OF ILLUSTRATIONS

FigurePage

1	Boom-to-Mast Bracket.....	1-4
2	Boom Assembly.....	1-5
3	Element Location	1-6
4	Element-to-Boom Bracket.....	1-6
5	Element Tubing Clamps.....	1-7
6	Rope Dampening	1-8
7	Element Tubing Descriptions.....	1-9
8A	Exposed Tubing Lengths, LP-1009, American.....	1-10
8B	Exposed Tubing Lengths, LP-1009, Metric.....	1-11
9	Feedline Assembly, Front Section	1-12
10	Feedline Assembly, Middle Sections.....	1-13
11	Feedline Assembly, Rear Section	1-14
12	Installing Elements on the Boom.....	1-15
13	Boom Support Cable Assembly.....	1-16

CHAPTER 1

General Information

General Description

The LP-1009 log-periodic antenna is a medium gain unidirectional antenna with an instantaneous bandwidth of 13 to 30 MHz under 2:1 VSWR. The LP-1009 also covers the 10,12,15,17 and 20 meter Amateur bands. It is supplied with the new HyGain BN-4000 high power balun which allows the antenna to handle 2000 watts continuous-duty and 4000 watts PEP on all modes.

All-stainless steel hardware and clamps are used on all electrical and mechanical connections of the LP-1009. The LP-1009 may be rotated with HyGain's T2X or HDR-300 rotators, and may be installed on any tower rated for at least 12.5 square feet wind load.

Specifications:	
<i>Electrical</i>	
Freq. Range:	13.0 - 30.0 MHz
Maximum Power:	2000 watts ave., 4000 watts PEP
Polarization:	Horizontal
Forward Gain:	min: 4.7 dBd, 6.9 dBi, 12.9 dBi/above flat earth 60-100' max: 5.3 dBd, 7.5 dBi, 13.5 dBi/above flat earth 60-100' ave: 5.0 dBd, 7.2 dBi, 13.2 dBi/above flat earth 60-100'
Half-Power Beamwidth:	(E-plane) min: 65 degrees max: 73 degrees ave: 68 degrees
Front-to-Back Ratio:	10 dB min. from 13.0 to 14.0 MHz 15 dB min. from 14.0 to 30.0 MHz ave: 17 dB (14-30 MHz) max: 22 dB (14-30 MHz)
Maximum VSWR:	2.0:1
Nominal Impedance:	50 ohms
Input Connector:	SO-239 Teflon (UHF) standard on 1009A UG-58 (Type N) standard on 1009AN
<i>Mechanical</i>	
Number of elements:	12
Boom Length:	27 feet (8.2m)
Boom Diameter:	2 inches (51 mm)
Accepts Mast:	1.9" OD to 2.5" OD (50 to 64 mm) (Not Supplied)
Wind Area:	12.5 sq. ft. (1.16 sq. m.)
Net weight:	95 lb. (43 kg.)
Longest Element:	39' 2.5" (11.95 m)
Turning Radius:	22' 6" (6.86 m)
Wind Survival (no ice):	103 MPH (165 kmph)
Hardware:	Stainless steel
Clamps and brackets:	Aluminum and hot-dipped galvanized
Boom Support:	"V" truss, 0.125 inch galvanized aircraft cable with 4 heavy-duty turnbuckles at mast attachment
Suitable Rotators:	Hy-Gain HDR-300, or T ² X

Theory of Operation

The design of the LP-1009 is based on a 12 element log-periodic dipole array with a 'TAU' of 0.896 and a 'SIGMA' of 0.05. These parameters give the LPDA a gain of approximately 7.2 dBi, a front-to-back ratio of approximately 17 dB, and maximum VSWR of 1.8:1. The mechanical design of each element was optimized by computer analysis to provide minimum weight and wind area yet survive wind speeds of at least 100 mph (165 kph).

Preparation for Assembly

The United States uses American units of measurement. Please see page 2-8 of this manual for American-to-metric conversion information. Most illustrations in this manual contain both American and metric dimensions.

When unpacking your antenna, check inside of all tubing for smaller diameter tubes and other small parts. To conserve space, these smaller parts are sometimes packed inside larger pieces. Check all parts against the parts list to ensure no parts are missing. The hardware supplied with this antenna is bagged by thread size for your convenience.

You may want to sort the aluminum tubing for the elements before assembly. This makes element assembly much easier. The following table shows the various element tubing sizes and quantities.

TUBING SIZE	QUANTITY SUPPLIED
1 1/4" x 64 3/4" with insert	2
1 1/4" x 59" with insert	2
1 1/4" x 37 3/4" with insert	2
1 1/4" x 20 1/2"	2
1 1/4" x 17"	2
1 1/4" x 15"	6
1 1/8" x 42"	2
1 1/8" x 36"	4
1 1/8" x 31 7/8"	4
1 1/8" x 17"	6
7/8" x 55"	4
7/8" x 51 "	4
7/8" x 46"	4
7/8" x 34"	4
7/8" x 24"	4
7/8" x 15"	4
5/8" x 28"	2
5/8" x 24"	20
5/8" x 16"	2
7/16" x 58"	2
7/16" x 55"	6

TABLE 1

Choose a large, clear area to assemble your antenna. The area must be at least 28' x 38' (8.5 m x 11.6 m). You may wish to use a temporary mast with sawhorses to support the boom during assembly. A concrete driveway or parking area is an excellent area for assembly. If you assemble this antenna over a grassy area, precautions should be taken so that hardware is not accidentally lost during assembly. We have included some extra small parts with this product, just in case some are lost.

All tubing supplied with the LP-1009 antenna telescopes together. Make all measurements to the given dimensions, plus or minus no more than 1/8 inch (3 mm).

TOOLS: The following tools are required for easy assembly.

Tape measure, 12 feet	1
Adjustable wrench, 8 inch	2
Nut Driver, 5/16" (element compression clamps)	1
Nut Driver, 3/8" (#10 hardware)	1
Nut Driver, 7/16" (element-to-boom clamps)	1
Nut Driver or open-end wrench, 1/2" (boom-to-mast)	1

We suggest that the assembly of this product be done over at least a 2 day period. We further suggest that you read this manual thoroughly, in its entirety, and then go through the manual a second time and identify and familiarize yourself with all of the antenna components. Start assembling the antenna when you are prepared. A few extra minutes invested in the assembly process will ensure many years of satisfaction with this antenna.

NOTE: An extra page that contains Figures 8A and 8B, Element Assembly, has been inserted in this manual for use when assembling the elements.

Installation

The Hy-Gain LP-1009 Log-Periodic Antenna requires a supporting tower structure which is at least 50' (15.2 m) in height above ground level and which will support at least 12.5 sq. ft. (1.1 sq. m) wind surface area. A support mast is not supplied with this antenna. Mast height will vary according to installation. A standard 10 foot mast will suffice in most cases. This antenna may also be installed atop buildings or other structures. In these cases, the antenna should be at least 10' (3 m) above a peaked roof and at least 20' (6.1 m) above a large flat roof. Performance may be degraded at less than these heights, depending upon the amount of metal in the roof and/or attic. Other nearby antenna structures, power lines, and guy wires may also affect the performance of this antenna.

The LP-1009 also requires a suitable rotator, if not installed in a fixed azimuth. Suitable rotators include Hy-Gain models T2X and HDR- 300.

Corrosion Precautions

The LP-1009 antenna is designed to be relatively maintenance free for most environments. All hardware is made of passivated stainless steel, typically grade 304. The internal tooth-type lockwashers used in this antenna are grade 410 stainless steel, and are slightly magnetic. The element tubing clamps are grade 304 stainless steel. The set of boom support clamps is hot dipped galvanized steel. Most other metallic parts are aluminum. All insulators exposed to sunlight are made from U.V. resistant black polyethylene or black Cycloac.

We have supplied a 3 oz. tube of Penetrox-ATM from Burndy Corporation for use as an anti-oxidant within element tubing assemblies. This prevents aluminum oxide from forming on the aluminum surfaces, especially in coastal environments.

Before assembling the tubing sections, abrade the mating surfaces with a wire brush or sandpaper. Apply the anti-oxidant to both surfaces, then assemble joint. Wipe off any excess material.

A light amount of clear lacquer or an acrylic spray may be used to coat the exterior surface of the element assemblies if this antenna is to be installed near a sea coast. Tighten all joints securely before coating! Also, if installed near a sea coast, the solder lugs on the pigtail wire assemblies should not touch the aluminum tubing or clamp directly. Each solder lug should be between 2 stainless steel flatwashers. Tighten these connections securely and completely coat with Scotchkote or RTV.

NOTE: Only use alcohol-based RTV (non-corrosive). The acid-based RTV (which releases acetic acid and smells like vinegar) will corrode metal.

If a UHF connector (PL-259) is used with the BN-4000 balun, seal the connector with Coax-Seal (TM) or black electrical tape for rain protection. Type N connectors are designed to be weatherresistant if tightened securely.

Select the boom-to-mast bracket and clamp parts. Loosely assemble them on the boom ends as shown in Figure 1.

Secure the boom ends and brackets together with four (4) 1/4"-20 x 3/4" bolts, lockwashers and nuts (70, 75, 76), and two (2) 5/16"-18 x 2 3/4" bolts, lockwashers and nuts (80, 82, 83). Tighten these six bolts securely. The casting-to-boom bracket (7), may deform slightly when the four 1/4" bolts are tightened. This is normal.

Assemble the two cast aluminum brackets (1) on your temporary mast at about 4 feet (1.2 m) above ground. A seven foot length of 2" ABS or PVC plastic drain pipe makes an inexpensive temporary mast. Secure the two brackets together using the two (2) 5/16"-18 x 3" bolts, lockwashers and nuts (78, 82, 83). Tighten these two bolts evenly until the brackets are snug.

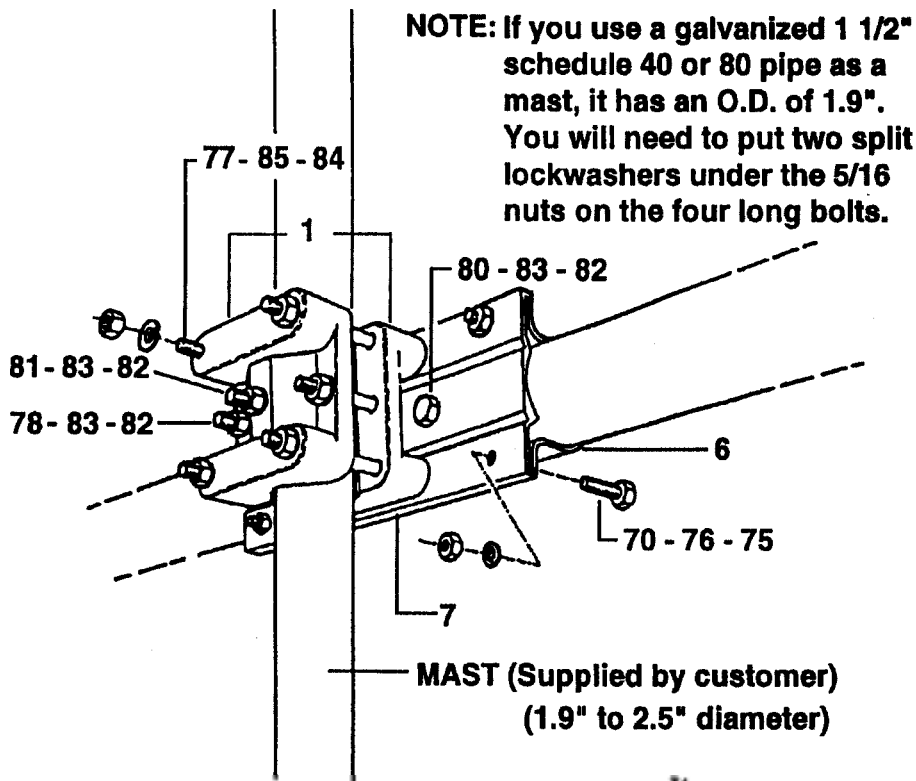

Item No.	Description
1	Mast Bracket, cast aluminum
6	Clamp, Boom-to-Bracket
7	Bracket, Casting-to-Boom
70	Bolt, hex head, 1/4"-20 x 3/4"
75	Nut, hex, 1/4"-20
76	Lockwasher, internal, 1/4"

Item No.	Description
77	Bolt, hex head, 5/16"-18 x 5"
78	Bolt, hex head, 5/16"-18 x 3"
80	Bolt, hex head, 5/16"-18 x 2 3/4"
81	Bolt, hex head, 5/16"-18 x 4"
82	Nut, hex, 5/16"-18
83	Lockwasher, split, 5/16"

Figure 1
Boom-to-Mast Bracket

Attach the boom and bracket assembly to these two brackets using the four (4) 5/16"-18 x 5" bolts, lockwashers and nuts (77, 82, 83). If you have problems aligning all of the holes in the brackets, you may wish to carefully run a 5/16" drill bit through these holes. Do not enlarge these holes beyond 5/16" or you may weaken the brackets. This will prevent alignment problems that might occur on the top of your tower!

Tighten these four bolts just enough to hold the weight of the antenna.

Slip the remaining boom sections over the swaged ends of the assembled boom and secure as shown in Figure 2.

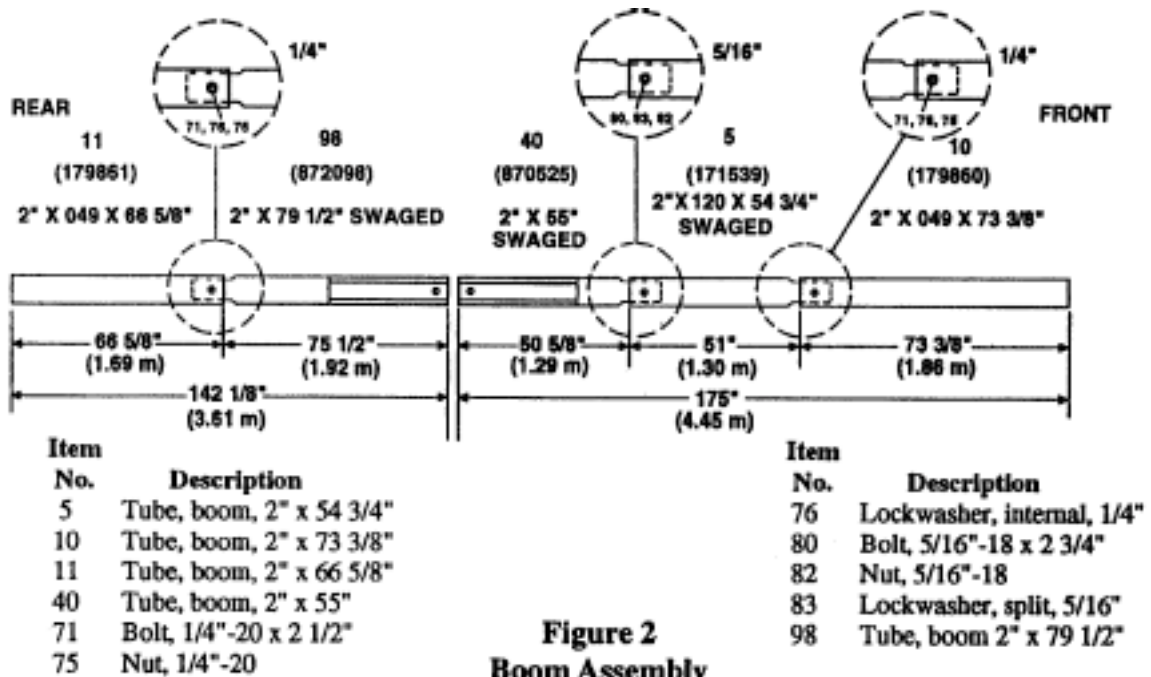

Figure 2
Boom Assembly

Assembly of the Element-to-Boom Brackets on the Boom

There are two sizes of element-to-boom brackets supplied with the LP- 1009 antenna. The largest has a 1 1/2" I.D., and is used on the 8 longest elements and the boom support tubes. The remaining brackets have a 1 1/4" I.D., and are used on the 4 front elements.

The largest brackets are stamped with the number 14, while the smaller brackets are stamped with the number 13.

Assemble the brackets as shown in Figure 4 and locate them on the boom assembly as shown in Figure 3. It is easier to assemble the brackets on the boom at the correct location, rather than try to slide them on the boom. If you are going to leave this assembly unattended for more than 15 minutes, we suggest that you tighten the eight (8) bolts on each bracket, so that they do not vibrate off. Do not tighten the anchor bolt on the bottom of the brackets until the elements are installed and aligned. Install the boom support tubes (17) and brackets (2) also at this time! The boom support brackets will have both top and bottom anchor bolts.

NOTE: The longest element (#12) uses top AND bottom anchor bolts! All other elements use only bottom anchor bolts!

You may want to mark the bracket location on the boom with an indelible marker. You can quickly realign the brackets to these marks when you install the elements in a later step.

Installation of Tubing Clamps on Elements

Select the proper size tubing clamps as shown in Figure 5. When installing the clamps, place the clamp near the tube end with the top of the clamp over the slot in the tube as shown in Figure 5.

After adjustment of the tubing lengths, tighten the clamp with a 5/16 inch nut driver, socket or open end wrench until the tubing will not twist or telescope. DO NOT overtighten! Also, if you loosen and re-tighten a clamp more than 5 times, we suggest that you replace the clamp. After repeated tightenings, these clamps may become difficult to completely tighten. Should you need to replace these clamps, use only high quality stainless steel clamps to ensure proper torque.

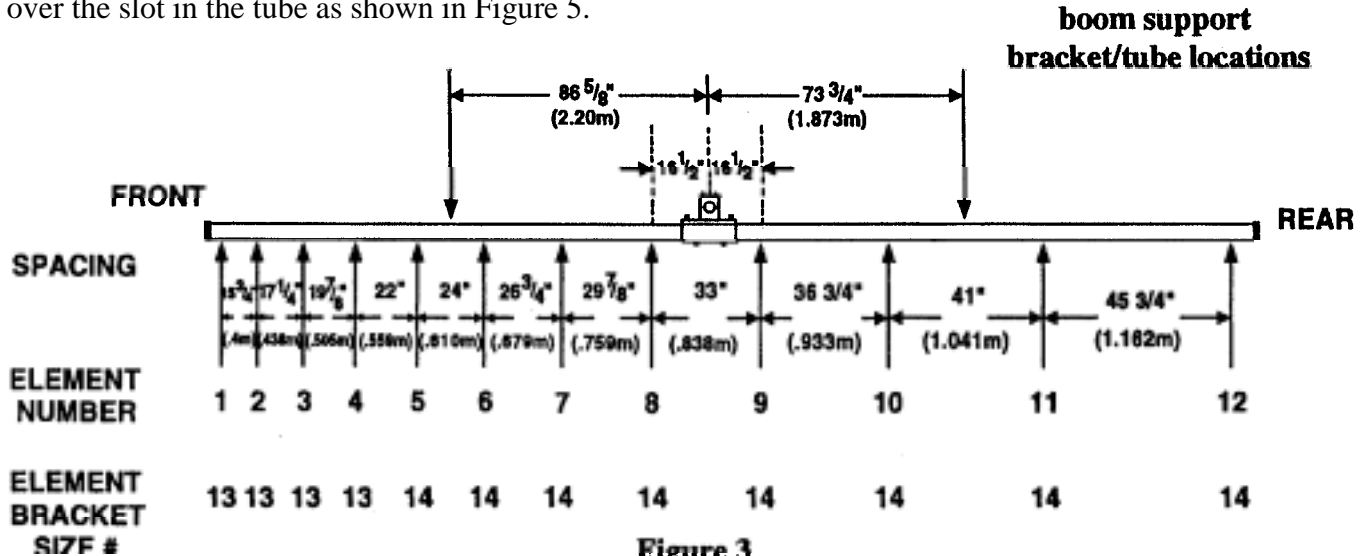
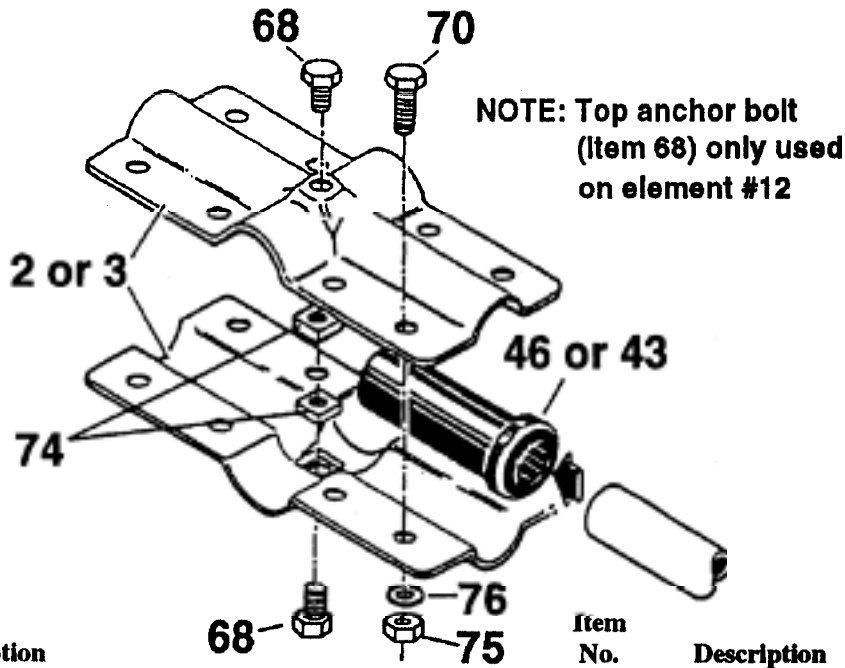

Figure 3
Element Location



Item No.	Description
2	Bracket, element-to-boom, #13
3	Bracket, element-to-boom, #14
43	Insulator, Driven Element, 1 1/4" OD
46	Insulator, Driven Element, 1 1/2" OD
68	Bolt, hex head, 1/4"-20 x 3/8"

Figure 4
Element-to-Boom Bracket

Item No.	Description
70	Bolt, hex head, 1/4"-20 x 3/4"
74	Nut, square, 1/4"-20
75	Nut, hex, 1/4"-20
76	Lockwasher, internal, 1/4"

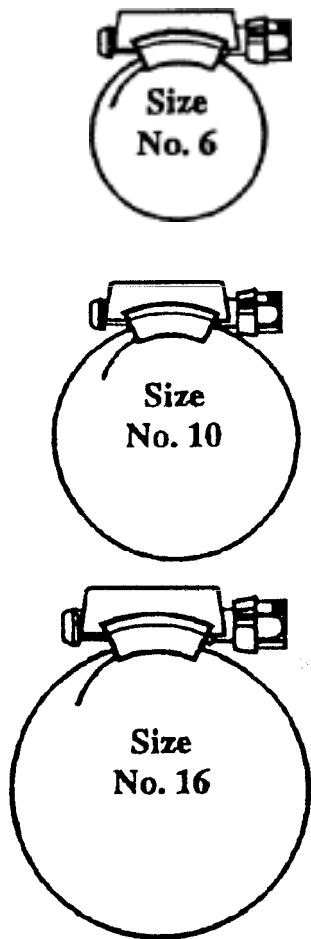
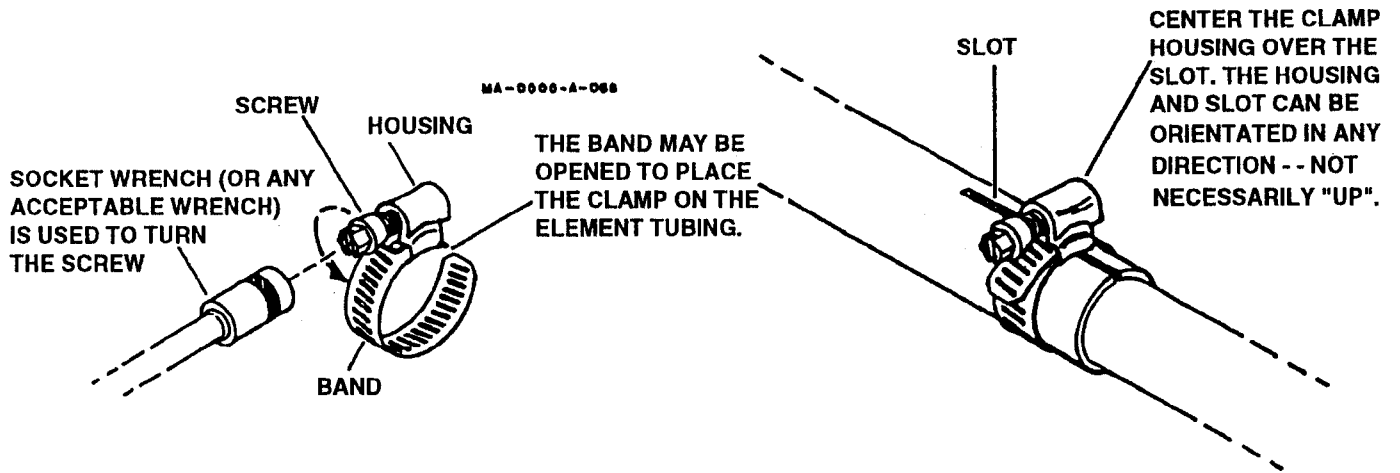

Part No.	Description	Fit Tubing Sizes
358756	Clamp, Size #6 all stainless steel 5/16" hex head screw	1/2 and 3/4"

Part No.	Description	Fits Tubing Sizes
358757	Clamp, Size #10 all stainless steel 5/16" hex head screw	1"

Part No.	Description	Fits Tubing Sizes
358758	Clamp, Size #16 all stainless steel 5/16" hex head screw	1 1/4"

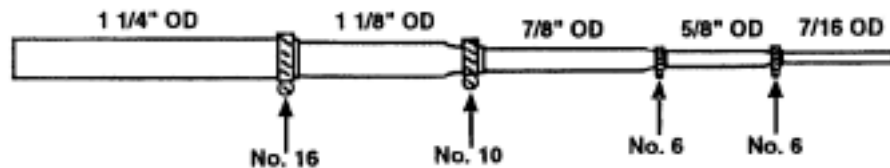

Figure 5 Element Tubing Clamps

Element Assembly

Use Figure 7 to select the tubing for each element. If you previously sorted the tubing, this step will be much easier. Each element uses two identical element halves. Assemble both halves of each element at the same time.

Starting with the longest element (#12), accurately measure the exposed tubing lengths as shown in Figure 8. Tighten the tubing clamp after each measurement. Repeat for the other element half. Double-check all the measurements before you proceed. You may want to mark each element half with its position in the antenna with an indelible marker. For example, mark each of the longest element halves with #12. The shortest set of element halves will be #1. The longer elements will use tubing with strengthening inserts. The inserts go towards the boom end of each element. Select the 7/8" and 1 1/4" element insulators, and 7/8" and 1 1/4" tubing clamps. Install them on the large end of each element.

Select the 5/32 inch black rope. Cut it into 24 equal lengths of 5'(1.5 m) each. Slip each rope piece into the outside tube (7/16") of each element. With about 1/2" (13 mm) of rope extending from each element half, fray the rope into individual fibers, and then fold the fibers back along the outside of the tube. See Figure 6. Slip a 7/16" caplug over the element end and rope fibers. Push the caplug on so that it is secure. This rope prevents low-frequency oscillations that may occur at low wind speeds. Set the assembled elements aside. The feedline will be attached to the boom before the elements.

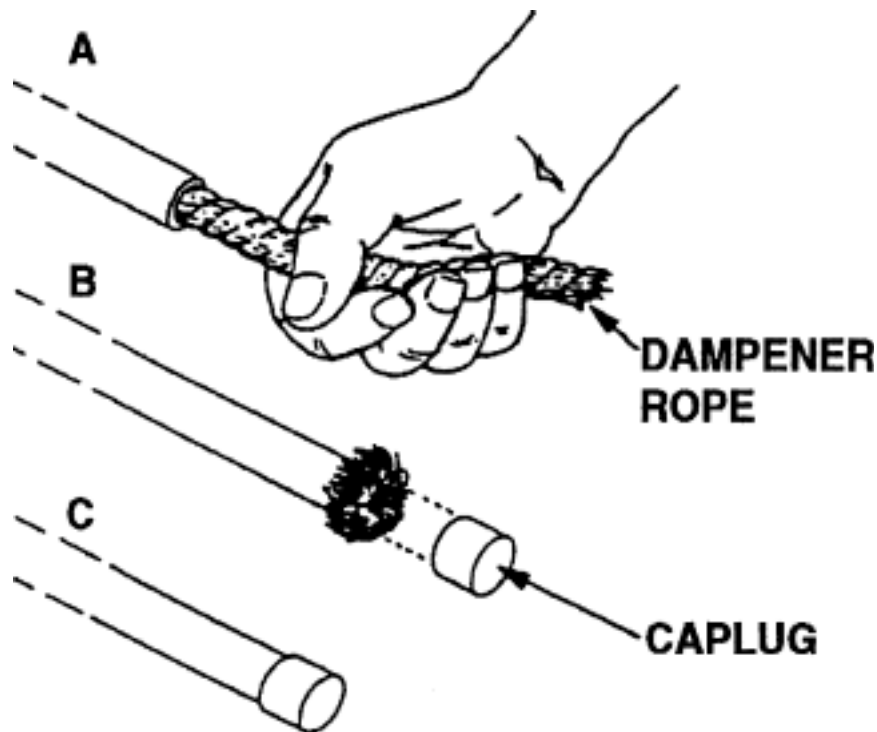

Figure 6 Rope Dampening

Feedline Assembly

Select the eight (8) 3/4" feedline tubes, six (6) 7/8" x 2" splice tubes, pigtail wire assemblies, support clamps, insulators and hardware as shown in Figure 9, 10, 11. The rear end of each feedline tube is identified with a label. This label also indicates which element is connected at that point. Assemble the feedline tubes and splice tubes together as shown, using #10-24 x 1 1/4" screws, #10 internal tooth lockwashers, #10 split lockwashers and #1024 hex nuts. Slide the 5/16" diameter spacer tubes into the open ends of the feedline tubes when installing pigtail wire assemblies for elements #1 and #12. These will prevent the screws from crushing the tubing at these points. Install the pigtail wire assemblies on the tubes as shown. Before tightening the hardware, position the pigtail wires as shown.

NOTE: The pigtail wires must alternate from crossed to not-crossed, starting at the rear of the phasing tube assembly and progressing toward the front. This is the normal configuration of a Log-Periodic Dipole Array (LPDA). Make sure you follow the pigtail configurations of Figures 9 through 12.

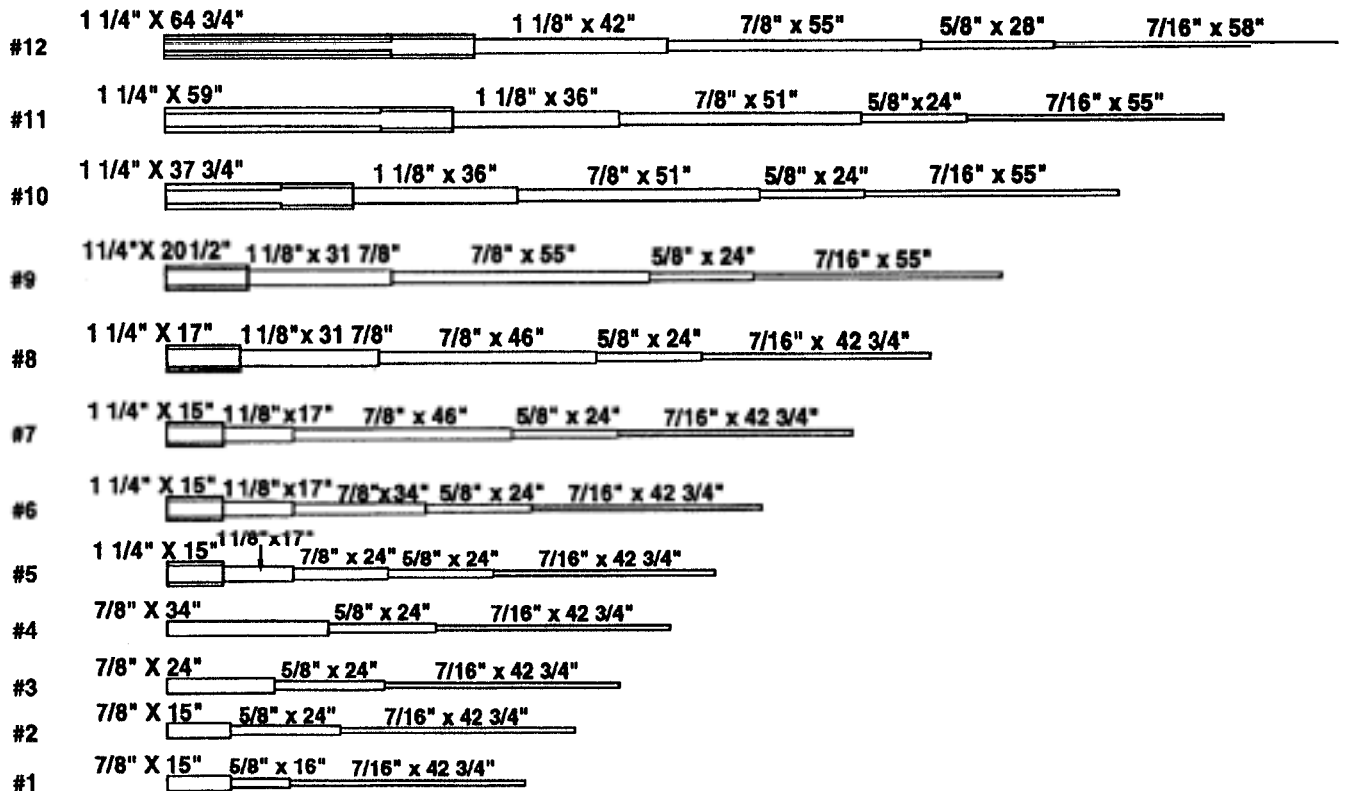

Figure 7

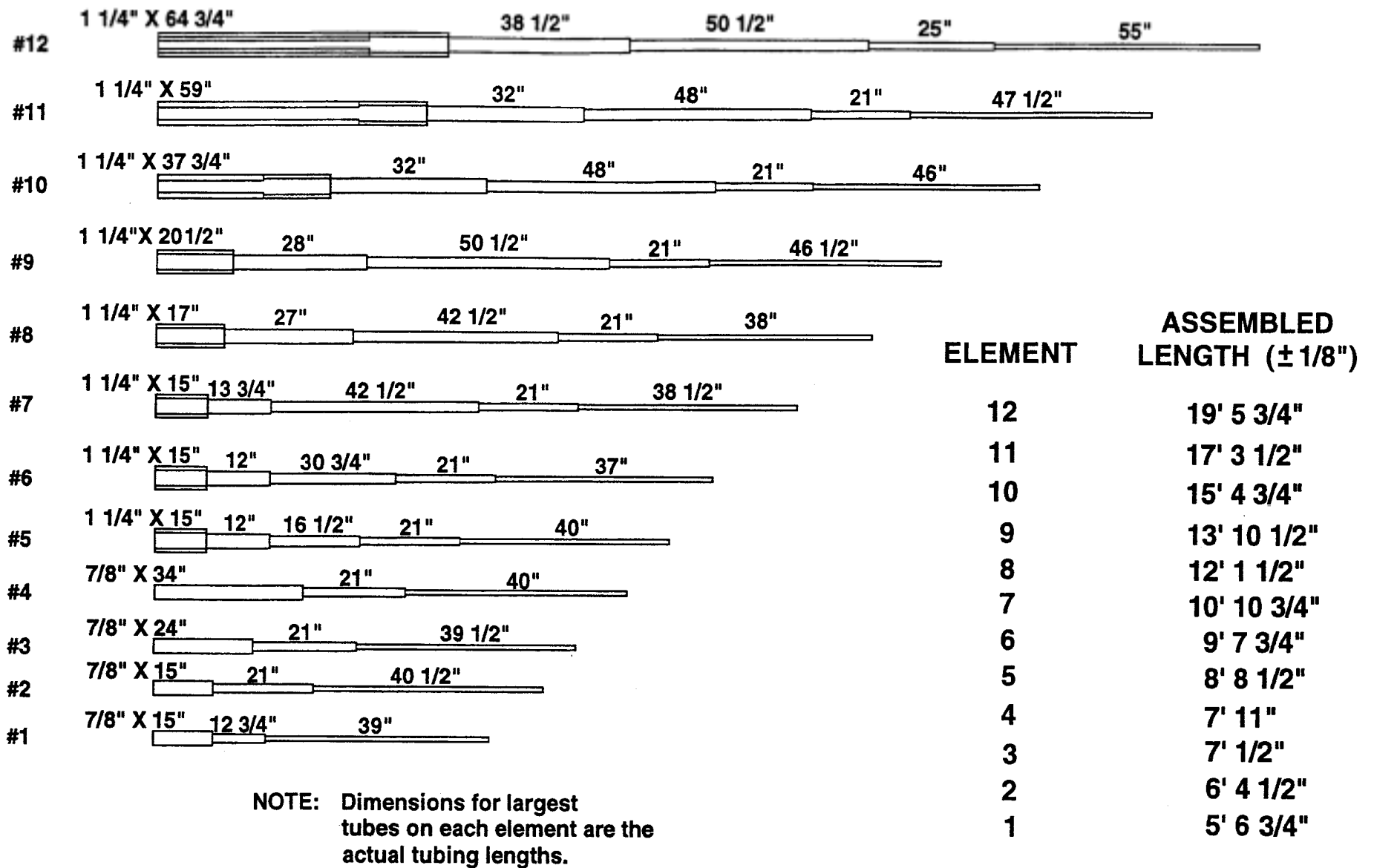
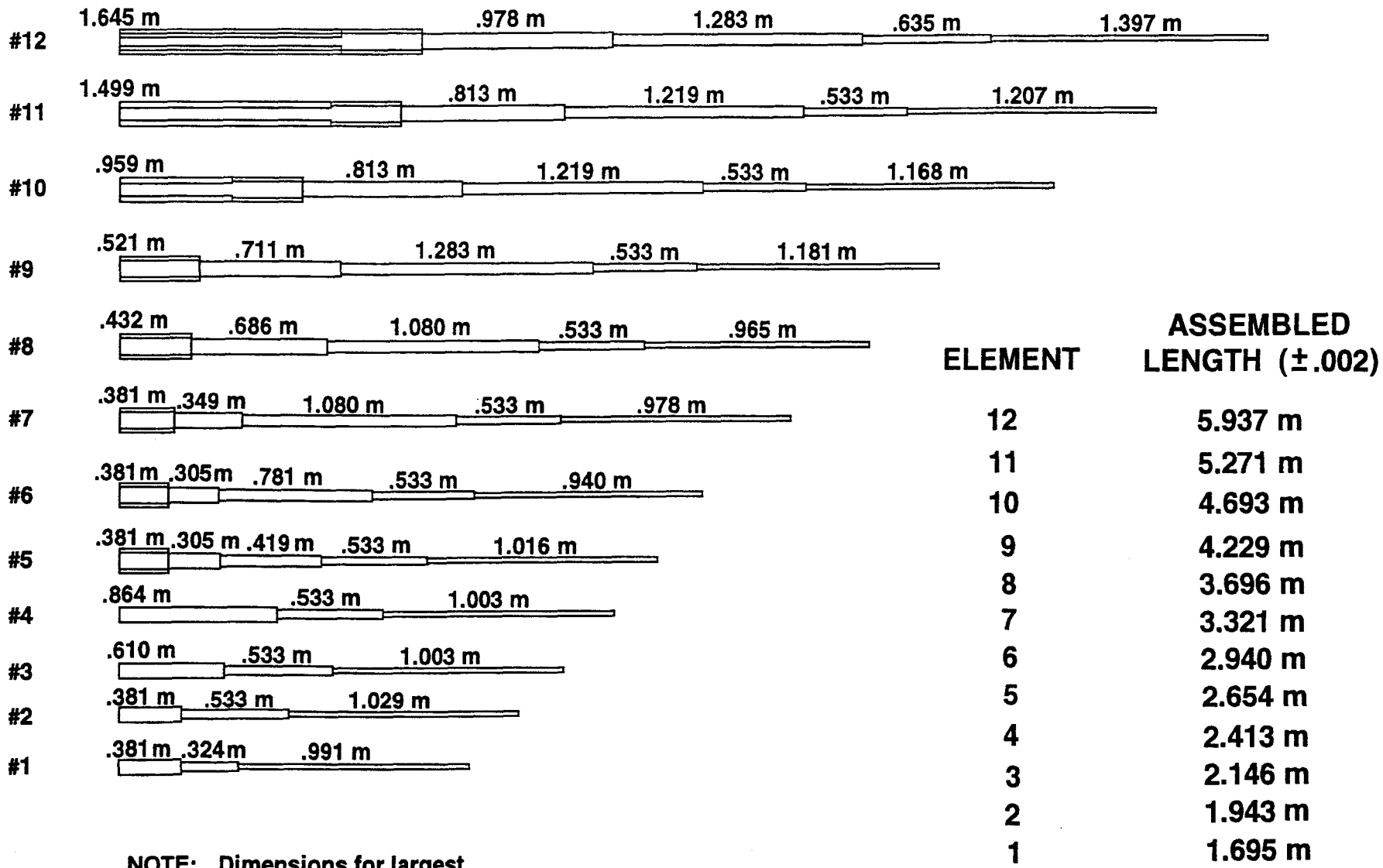

Figure 8A Exposed Tubing Lengths, LP-1009 American



NOTE: Dimensions for largest tubes on each element are the actual tubing lengths.

Figure 8B
Exposed Tubing Lengths, LP-1009 Metric

Lay the assembled feedline tubes above the boom with the support insulators in the correct positions. Attach the support clamps with the appropriate hardware as shown in Figure 9-11 Detail A. The feedline tubes should be centered on top of the boom, except where they go around the boom-to-mast brackets. Allow a 3/4" gap between the closest feedline tube and the boom-to-mast brackets. Tighten all hardware securely.

Beta Tube Assembly

Select the two 3/4" x 18" Beta Tubes, support clamps, insulators, shorting clamps and hardware and assemble to the bottom side of the boom as shown in Figure 11. Use the 5/16" diameter spacers to prevent crushing the tubing where the pigtail wires attach. Tighten all hardware securely. This assembly provides a D.C. ground to the feedline and helps to match the antenna in the 13 - 14 MHz range.

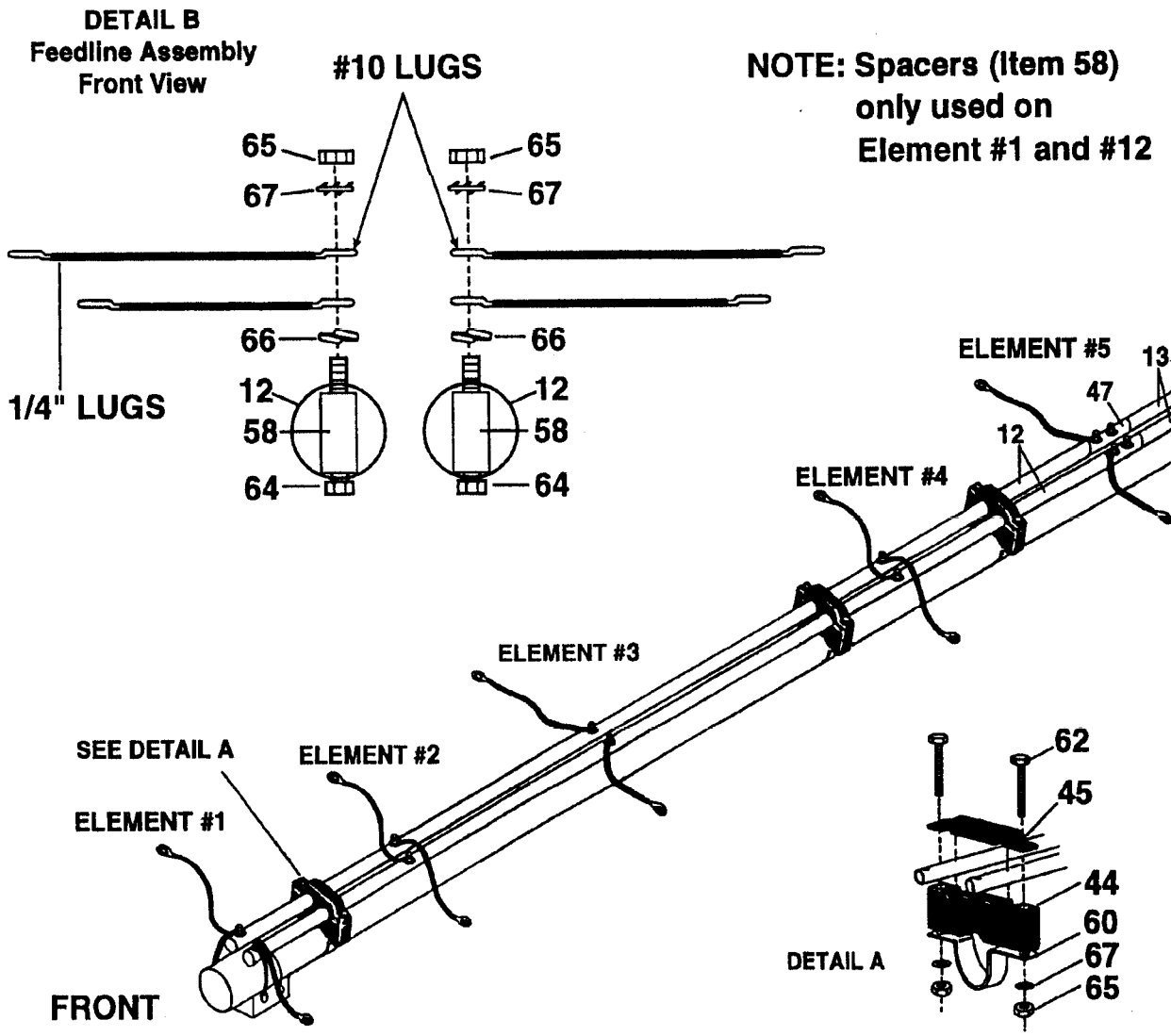

Item No.	Description
6	Clamp, boom-to-bracket
7	Bracket, casting-to-boom
12	Tube, front feedline, 3/4" x 75 7/8"
13	Tube, front-center feedline, 3/4" x 80 5/8"
44	Insulator, support (bottom)
45	Insulator, support (top)
47	Splice, aluminum, 7/8" x 2"
58	Beta sleeve, 5/16" x 5/8"
60	Clamp, support

Item No.	Description
62	Bolt, hex head, #10-24 x 2"
64	Bolt, hex head, #10-24 1 1/4"
65	Nut, hex, #10-24
66	Lockwasher, #10, split
67	Lockwasher, internal, #10
77	Bolt, hex head, 5/16"-18 x 5"

Figure 9
Feedline Assembly
Front Section

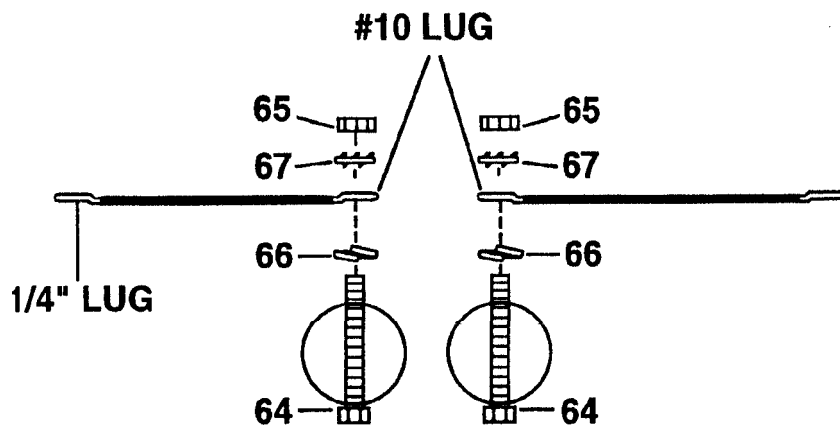

398S013

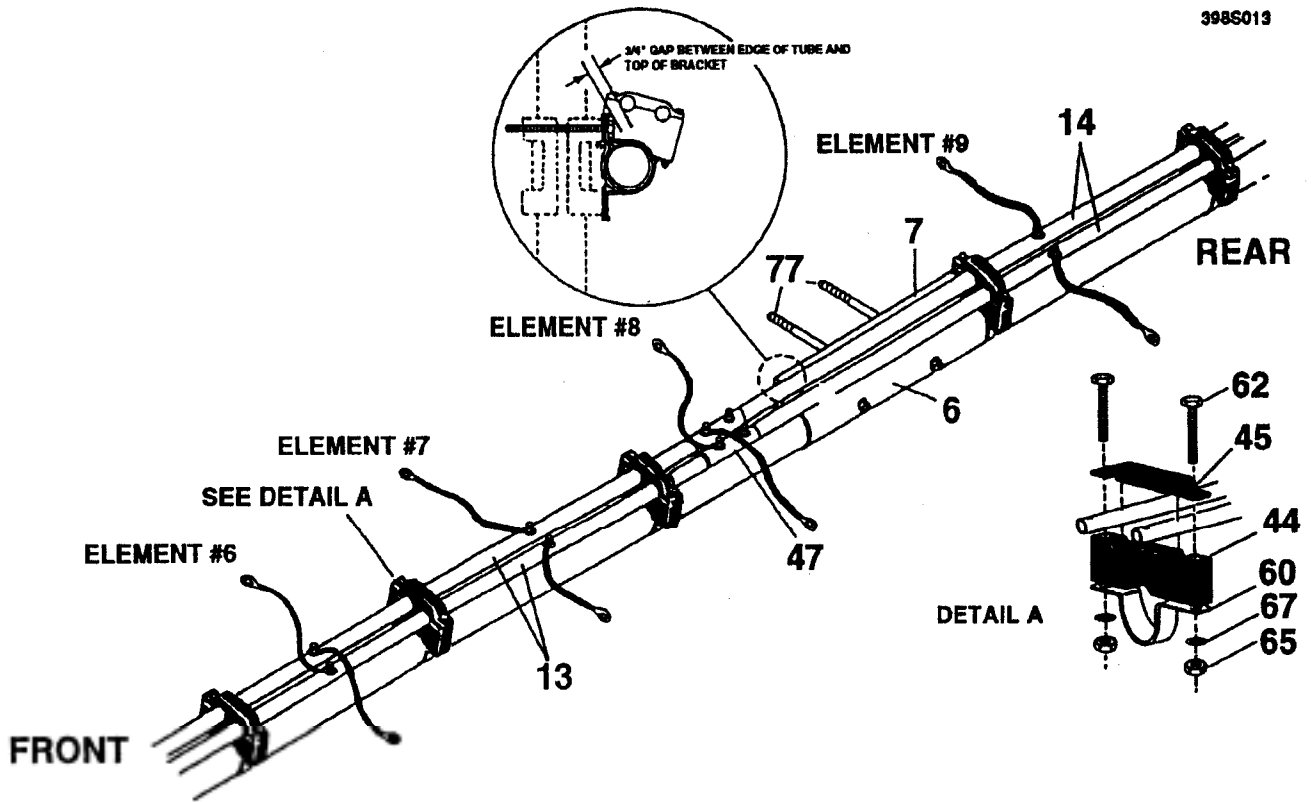

Item No.	Description
6	Clamp, boom-to-bracket
7	Bracket, casting-to-boom
13	Tube, front-center feedline, 3/4" x 80 5/8"
14	Tube, rear-center feedline, 3/4" x 69 3/4"
44	Insulator, support (bottom)
45	Insulator, support (top)
47	Splice, aluminum, 7/8" x 2"
60	Clamp, support

Item No.	Description
62	Bolt, hex head, #10-24 x 2"
64	Bolt, hex head, #10-24 1 1/4"
65	Nut, hex, #10-24
66	Lockwasher, #10, split
67	Lockwasher, internal, #10
77	Bolt, hex head, 5/16"-18 x 5"

Figure 10
Feedline Assembly
Middle Sections

**DETAIL B
Feedline Assembly
Rear View**

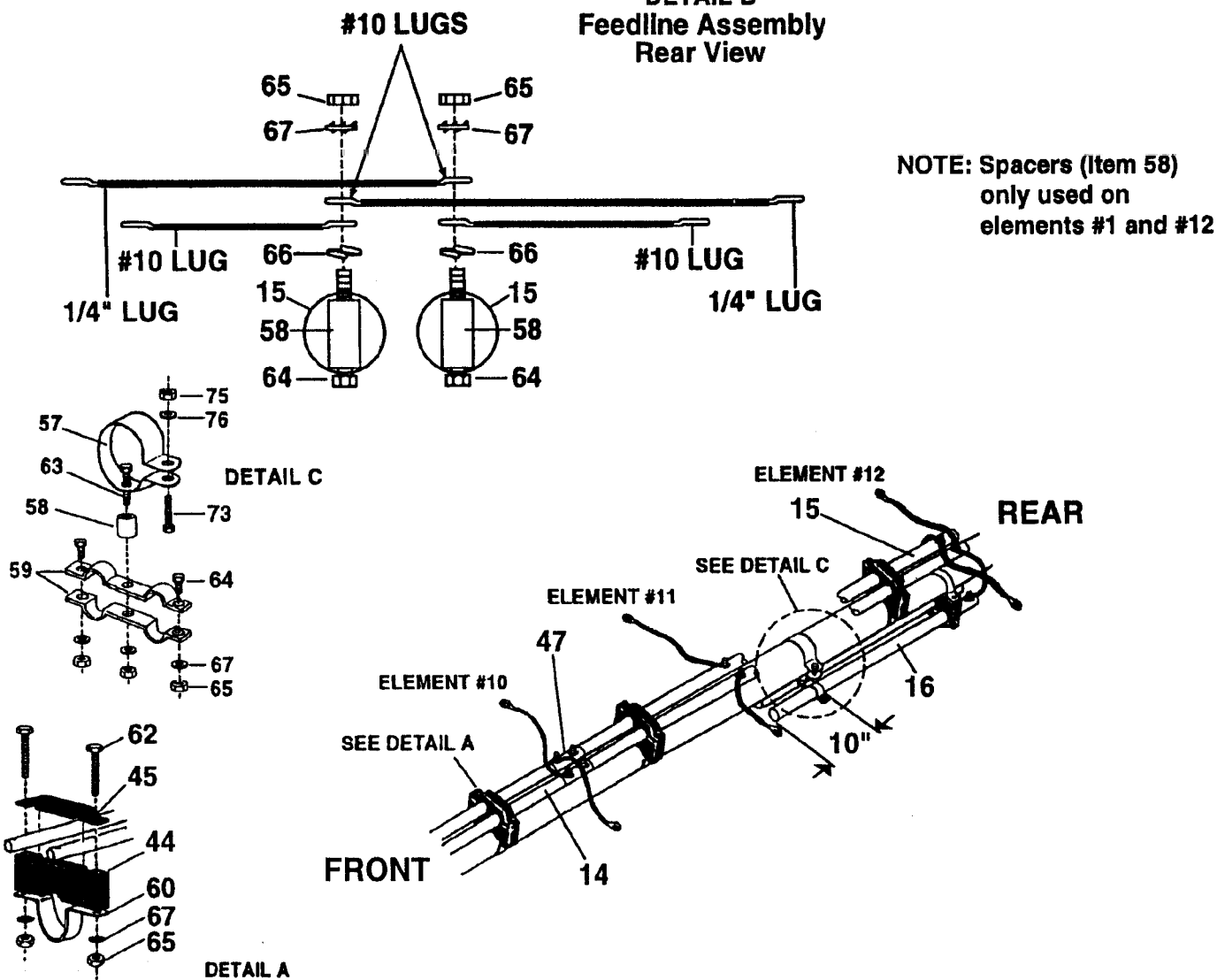

NOTE: Spacers (Item 58) only used on elements #1 and #12

Item No.	Description
6	Clamp, boom-to-bracket
7	Bracket, casting-to-boom
14	Tube, rear-center feedline, 3/4" x 69 3/4"
15	Tube, rear-feedline, 3/4" x 82 1/4"
16	Tube, beta, 3/4" x 18"
44	Insulator, support (bottom)
45	Insulator, support (top)
47	Splice, aluminum, 7/8" x 2"
57	Strap, boom support
58	Beta sleeve, 5/16" x 5/8"
60	Clamp, support

Item No.	Description
62	Bolt, hex head, #10-24 x 2"
63	Bolt, hex head, #10-24 x 1 1/2"
64	Bolt, hex head, #10-24 x 1 1/4"
65	Nut, hex, #10-24
66	Lockwasher, #10, split
67	Lockwasher, internal, #10
73	Bolt, hex head, 1/4"-20 x 1 1/4"
75	Nut, hex, 1/4"-20
76	Lockwasher, internal, 1/4"
77	Bolt, hex head, 5/16"-18 x 5"

**Figure 11
Feedline Assembly**

Installing Elements on the Boom

You should now have 24 completely assembled element halves. If you have both ends of the boom supported, you may start with element #1 at the front of the boom. If you do not have the boom ends supported, start with the elements near the center of the boom and proceed to each boom end, keeping the antenna balanced.

Insert the insulated end of each element half into the corresponding bracket on the boom and tighten the eight (8) 1/4"-20 x 3/4" bolts. Position the element compression clamps on the elements to the top side if the antenna will be raised over tower guy wires. Do not tighten the center anchor bolts until all elements are aligned in the same plane. Before you proceed to the next element, attach the pigtail wires to the tubing clamps as shown in Figure 12. Use 1/4"-20 x 1 1/4" bolts on the small clamps and 1/4"-20 x 1 1/2" bolts on the large clamps. Tighten these bolts securely.

Align each element so that it is parallel to the ground and perpendicular to the temporary mast. If you have a flat assembly area, you can use visual references, such as corners of structures and horizontal lines in exterior walls to align each element. When all elements are aligned, securely tighten the center anchor bolts and recheck the tightness of the other eight (8) bolts on each bracket.

Balun Assembly

Attach the BN-4000 balun to the boom, as shown in Figure 12. Use the U-bolt and #10-24 nuts. Attach the two 4 1/8" pigtail wires to the balun using 1/4"-20 x 3/8" screws and lockwashers. Tighten all hardware securely.

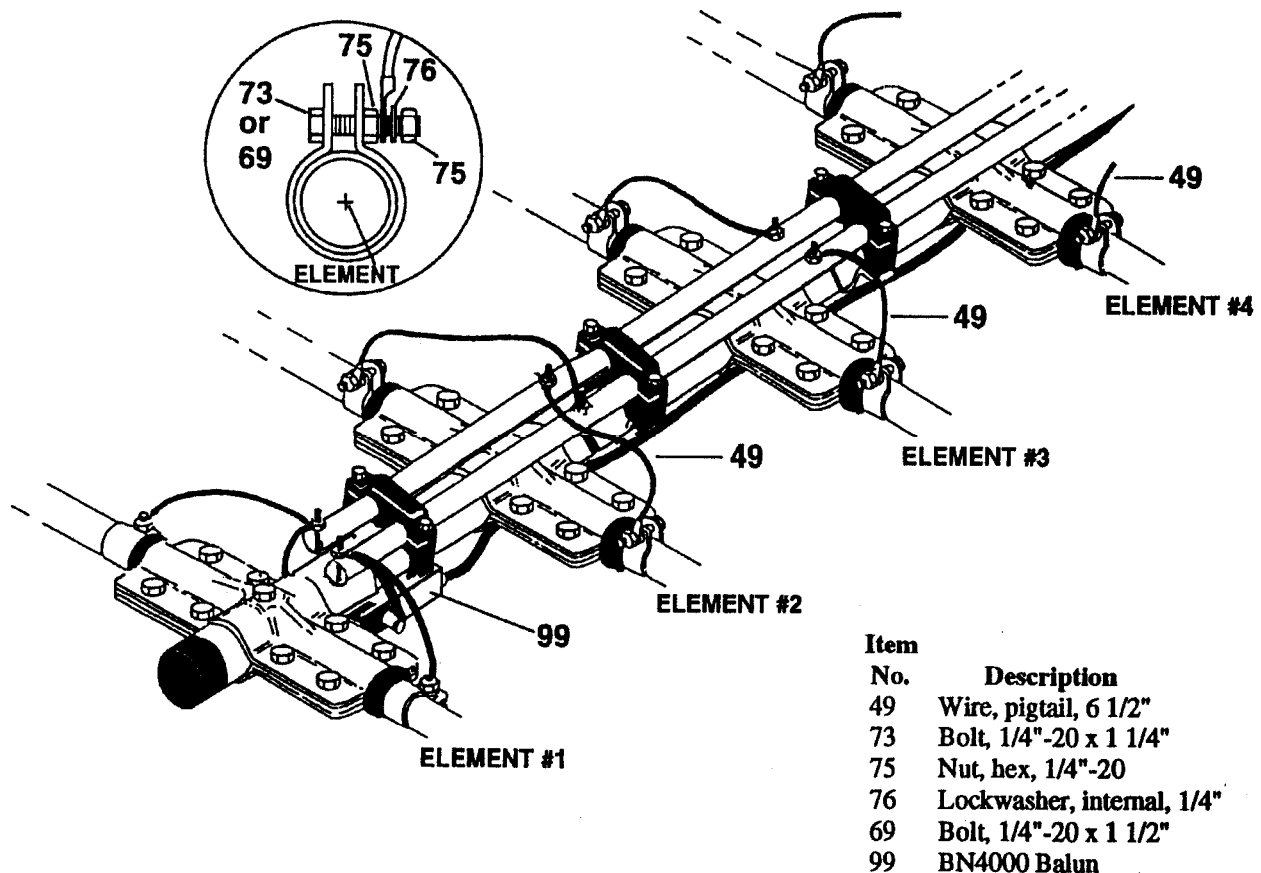
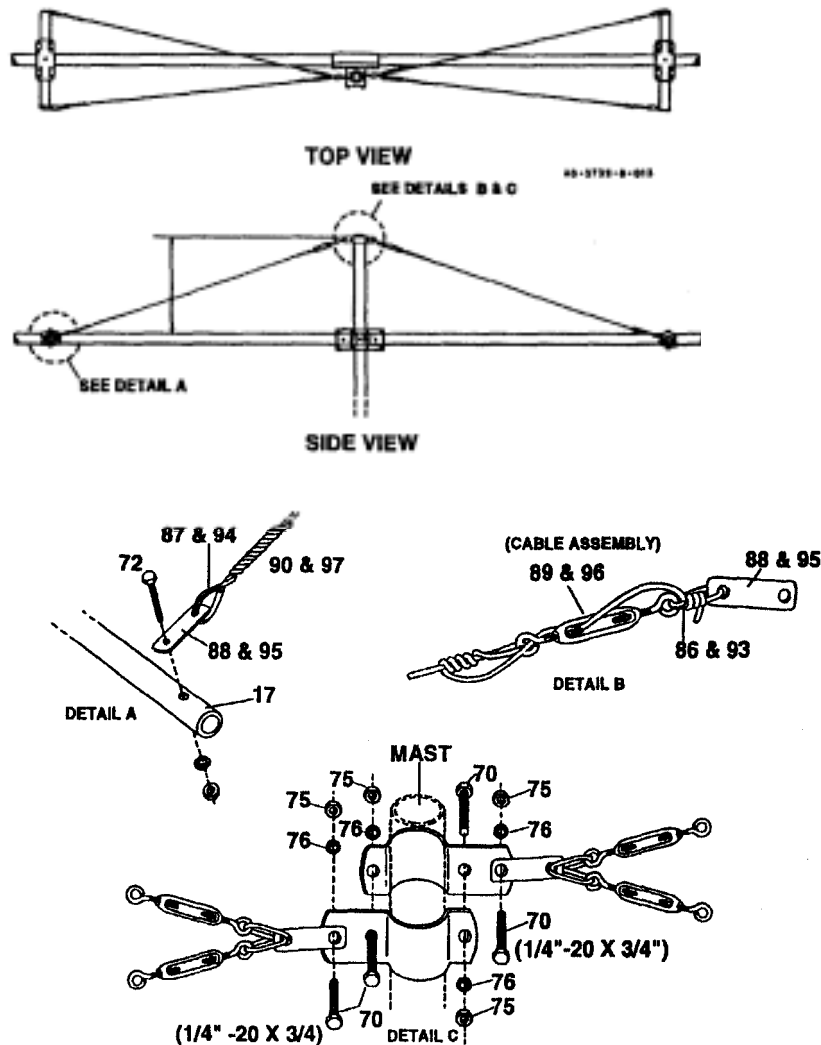

Figure 12
Installing Elements
on the Boom

Boom Support Assembly

Select the front boom support assembly, two (2) 1/4"-20 x 1 3/4" bolts, 1/4" lockwashers, and 1/4"-20 nuts. The front assembly is longer than the rear assembly. Assemble these to the front boom support tubes which were previously assembled to the boom. The cables should lay on the top of the elements.

Select the rear boom support assembly, two (2) 1/4"-20 x 1 3/4" bolts, 1/4" lockwashers, and 1/4"-20 nuts. Assemble these to the rear boom support tubes on the boom. Lay the cables on top of the elements. Adjust all four (4) turnbuckles so they are extended to their maximum length. Select and attach the two galvanized mast guy straps to your temporary mast approximately two (2) feet above the boom. See Figure 13. Attach the loose end of each of the cable assemblies to each side of the guy straps using two (2) 1/4"-20 x 3/4" bolts, 1/4" lockwashers, and 1/4"-20 nuts.



Item No.	Description
17	Tube, support, 1 1/4" x 8 5/8"
70	Bolt, hex head, 1/4" x 3/4"
72	Bolt, hex head, 1/4" x 1 3/4"
75	Nut, hex, 1/4"-20
76	Lockwasher, internal, 1/4"
86	Chain link, open end, 3/16"
87	Thimble, wire rope, 5/32"
88	Plate, 16 gauge, 5/8" x 2", punched

Item No.	Description
89	turnbuckle, end-to-end, #4, 1/4" x 4"
90	Cable, galv. 1/8" dia. 15.750 ft.
93	Chain link, open end, 3/16"
94	Thimble, wire rope, 5/32"
95	Plate, 16 gauge, 5/8" x 2", punched
96	Turnbuckle, end-to-end, #4, 1/4" x 4"
97	Cable, galv. 1/8" dia. 13.750 ft.

Figure 13
Boom Support Cable Assembly

Slide the assembled guy straps up the mast until the boom is level with the ground. Equalize the tension in each cable by tightening the turnbuckles. If required, the position of the boom support brackets can be adjusted slightly to equalize the cable tension. The turnbuckles must have full thread engagement. When satisfied, measure the distance between the mast guy straps and the boom-to-mast brackets and record. Use this distance to help level the boom when installing the antenna on the tower. Remove the mast guy straps from your temporary mast and tape to the boom near the boom-to-mast bracket.

Final Inspection

Make sure all connections are securely tightened, recheck element lengths and spacings, and ensure that there is good clearance between pigtail wires and tubing and brackets. Check for a 3/4" gap between the feedline and the boom-to-mast bracket. The top two 5" bolts in the boom-to-mast assembly should be captivated by the feedline tubes. The bottom two 5" bolts will be installed during antenna installation.

CHAPTER 2

Antenna Installation

IMPORTANT: The LP-1009 is a large and heavy antenna and requires some consideration as to how you are going to get it to the top of your tower. Thoroughly read this section before beginning to install your antenna!

Installation on a Crank-Up Tower

Crank the tower completely down or as low as it will go and block all sections from moving by using a 2" x 4" piece of wood or a solid iron bar for heavier towers. The block should be inserted through the lattice structure before the tower is completely down, then the tower can be cranked down until the block takes the weight off of the winch cable. ALL sections must be prevented from moving!

WARNING: Installation of this product near power lines is dangerous! For your safety, follow the instructions provided with your tower and the instructions in this manual.

Use a ladder to reach the top of the tower. **NEVER CLIMB THE LATTICE STRUCTURE OF ANY CRANK-UP TOWER!!** Attach the mast to the tower and rotator. The cast aluminum boom-to-mast brackets should be removed from your temporary mast and installed on the permanent mast as shown in Figure 1. The center hole in the cast brackets may be used to pin the brackets to the mast. If you wish to use this feature, you must drill a 5/16" hole through your mast at this location. Attach a gin pole to the tower or support structure to assist in lifting the antenna.

Installation on Guved Towers

When installing the LP-1009 on a guyed tower, you may wish to use a guide system. If you have insulators on your guy wires, you will need to keep the antenna away from the guy wires as well as the tower during the raising process. You can use two ropes attached together at the top of the tower and attached to the ground about 15 to 20 feet apart. These two ropes can be used to slide the antenna on as it is also being lifted. The two ropes will need to be far enough from the tower base to allow some sag and still support the antenna away from the guy wires. Remember that this antenna weighs 98 pounds! Trim any tree branches that might interfere with the installation process.

Remove the cast boom-to-mast brackets from your temporary mast and install on your permanent mast. Drill a 5/16" hole in your mast if you wish to pin the castings to the mast. This will ensure that your antenna does not twist on the mast in high winds.

Attachment of Coaxial Feedline

Use a good quality 50 ohm coaxial transmission line such as Times RG- 213/U (solid), or Belden 8267 (solid). Belden 9913 or 8214 is not required but may be used with careful connector installation. Belden 9913 should NOT be used above the rotator or on crank-up towers!! Take extra care when soldering connectors to foam dielectric coaxial cable. RG-213/U "TYPE" cable is not recommended because it usually has less shielding than better quality RG-213/U. Weatherproof all UHF connectors which will be exposed to rain or ice, with Coax-Seal (R) or another similar substance.

Attach the transmission line to the BN-4000 balun and tighten the connector securely. Tape the coax to the boom about every 3 feet (1 m) and provide suitable strain relief. Allow enough coax to reach your tower or other support structure.

Attaching the Antenna to the Mast

Attach the lifting rope to the balance point of the antenna. Be careful not to damage the feedline assembly next to the boom-to-mast clamp. The lifting rope should be fed through the gin pole or other pulley arrangement attached to the tower. The other end should be at ground level, available to the ground crew for lifting. Guide ropes may be LOOSELY looped over the boom ends and used by the ground crew to guide the antenna away from the tower, guy wires, tree branches or ladder. The guide rope's two loose ends should be held by the ground crew, so that the guide rope can be retrieved later.

When the antenna reaches the mast bracket, the top two 5" bolts should be inserted through the top two holes in the aluminum castings and secured using 5/16" - 18 lockwashers and nuts.

NOTE: Use a few drops of heavy motor oil or grease on the stainless steel threads to prevent galling! If these threads gall, you may have to cut the bolts with a hacksaw to remove the antenna!

The other two remaining 5/16"-18 x 5" bolts should now be installed and secured with lockwashers and nuts. Tighten all bolts securely. The bolt heads must be on the same side of the boom-to-mast brackets as the feedline tubing.

The boom support cable assemblies may now be untaped from the boom and attached to the mast. Slide the mast guy straps up the mast until the wires are taught and the boom is level. Check the dimension between the mast guy straps and the boom-to-mast bracket against your previous measurement. Equalize the tension in the wires using the turnbuckles. Tie off the turnbuckles so they do not loosen. Tighten all bolts securely! Tape the coaxial cable to the mast, leaving a loop for rotation. Check the direction of the antenna for use in calibrating your rotator.

Lightning Protection

For proper lightning protection, you must ground your antenna supporting structure. Grounding will also help with noise reduction. A proper ground consists of a 1/2" x 8 foot copper clad steel ground rod driven into the ground approximately 12" (0.3 m) away from the concrete tower base. Connect the tower to the ground rod using #8 copper wire and commercial non-corrosive ground clamps.

VSWR Curves

These VSWR curves are typical for the antenna mounted 70 - 80 feet above the ground and fed with 100 feet of RG-213/U cable. Similar curves can be expected for this antenna mounted between 50 and 100 feet above ground. **DO NOT TRY TO TUNE THIS ANTENNA FOR LOW VSWR AT GROUND LEVEL.** Higher VSWR can be expected if mounted at less than 40 feet or within 20 feet of a large roof or metallic structure. Guy wires within 10 feet of this antenna should be broken into non-resonant lengths (less than 12 foot lengths) and insulated from the tower. Other antennas which are resonant somewhere in the 3 - 40 MHz range should be kept at least 10 feet above or below this antenna. Antennas which are resonant above 40 MHz can be mounted as close as 3 feet from this antenna. The measured VSWR may also be affected by strong local broadcast signals.

Extreme care must be used if you use an air-dielectric coaxial cable such as Belden 9913. Water intrusion can easily raise the VSWR and loss.

Hy-Gain recommends the Bird Model 43 directional watt meter to measure reflected power and VSWR. This meter with the 250 watt 2 -30 MHz element will give the most accurate information.

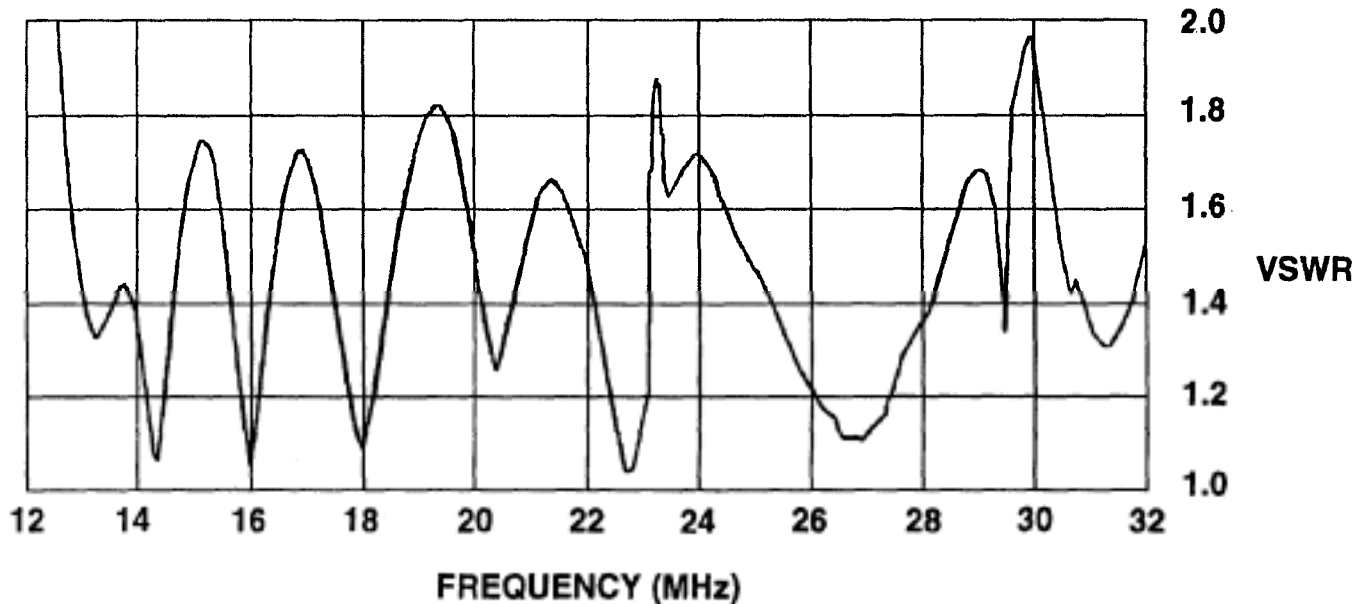

VSWR Curves

Troubleshooting

If you encounter problems with the operation of your LP-1009, follow these steps to isolate the cause of your problem.

Usually you can isolate problems that occur in either your antenna or coaxial feedline or balun. If you experience high VSWR on some frequency bands, look for assembly errors in the antenna element lengths and log-periodic feedline connections or nearby resonant structures or antennas.

If you have high VSWR on all frequencies, look for shorts, opens or water in the coaxial feedline. The balun and coaxial cable may also have been damaged by lightning.

Symptom:	Possible Causes:
VSWR above 3:1 on all frequencies.	Shorted coaxial connector. Water inside of coax. Coax damaged by lightning. Balun damaged by lightning. Antenna too close to roof. Antenna too close to ground. Balun not connected to antenna.
VSWR above 2:1 on all frequencies.	Antenna too close to roof. Antenna too close to ground. Antenna too close to wires.
VSWR above 2:1 from 13 - 14 MHz.	Antenna too close to ground. Beta tubes assembled wrong. Element #11 or #12 not assembled or connected right.
VSWR above 2:1 from 14 - 16 MHz.	Antenna too close to ground. Element #10 or #11 not assembled or connected right.
VSWR above 2:1 from 16 - 20 MHz.	Check elements 7, 8, 9, 10.
VSWR above 2:1 from 20 - 25 MHz.	Check elements 5, 6, 7, 8.
VSWR above 2:1 from 25 - 30 MHz.	Check elements 2, 3, 4, 5.
VSWR above 2:1 in one 200 KHz spot.	Adjust Beta short position.

Parts List

Item No.	Part No.	Description	
1	102734	Bracket, cast aluminum.....	2
2	165919	Bracket #13, 2 to 1 1/4" hvy	12
3	165920	Bracket #14, 2 to 1 1/2" hvy	16
4	171533	Tube, 7/16" x 57 7/8"	2
5	171539	Boom, tube, 2" x 54 3/4".....	1
6	172732	Clamp, boom-to-bracket	1
7	172735	Bracket, casting to boom.....	1
8	174939	Tube, 7/16" x 55"	6
9	175512	Tube, 7/16 x 42 3/4"	16
10	179860	Boom, tube, 2" x 73 3/8".....	1
11	179861	Boom, tube, 2" x 66 5/8".....	1
12	179862	Tube, front f.l. 3/4" x 75 7/8".....	2
13	179863	Tube, front center, f.l. 3/4" x'80 5/8"	2
14	179864	Tube, rear, center f.l. 3/4" x 69 3/4".....	2
15	179865	Tube, rear, Ll. 3/4" x 82 1/4"	2
16	179866	Tube, beta, 3/4" x 18"	2
17	179867	Tube, support, 1 1/4" x 8 5/8"	4
18	190004	Tube, 5/8" x 24"	20
19	190010	Tube, 5/8" x 28"	2
20	190011	Tube, 5/8" x 16"	2
21	190204	Tube, 7/8 x 24".....	4
22	190212	Tube, 7/8 x 15".....	4
23	190309	Tube, 1 1/8" x 42"	2
24	190311	Tube, 1 1/8" x36"	4
25	190312	Tube, 1 1/8" x 317/8 ".....	4
26	190315	Tube, 1 1/8" x 17"	6
27	190923	Tube, 1 1/4" x 20 1/2"	2
28	190924	Tube, 1 1/4" x 17".....	2
29	190925	Tube, 1 1/4" x 15"	6
30	191011	Tube, 7/8" x 55"	4
31	191016	Tube, 7/8" x 51"	4
32	191017	Tube, 7/8" x 46"	4
33	191018	Tube, 7/8" x 34"	4
34	380862	Strap, mast, guy.....	2
35	690190	5/32 poly black braid	2
36	850091	Penetrox A-3	1
37	870522	Tubing assembly, 1 1/4" x 37 3/4".....	2
38	870523	Tubing assembly, 1 1/4" x 59".....	2
39	870524	Tubing assembly, 1 1/4" x 64 3/4".....	2
40	870525	Boom tube, 2" x 55".....	1

Parts List

Item No.	Part No.	Description	Qty
	870535	Parts Pack, 1009 Ins. #1.....	1
41	455625	Caplug, black	2
42	455644	Caplug, 7/16", black.....	24
43	463767	Insulator, 1 1/4" OD.....	8
44	465595	Insulator, support, bottom	11
45	465600	Insulator, support, top	11
	870536	Parts Pack, 1009 Insulator, #2.....	1
46	465833	Insulator 1 1/2" OD.....	16
	870537	Parts Pack, Feedline	1
47	191012	Splice, 7/8" x 2"	6
48	870546	Pigtail wire, 4 1/8"	2
49	870547	Pigtail wire, 6 1/2"	2
50	878561	Pigtail assembly	8
51	879973	Pigtail assembly, 9 1/2".....	16
	870538	Parts Pack, 1009 Clamp, #16	1
52	358758	Clamp, hose, #16, 5/16"	18
	870539	Parts Pack, 1009 Clamp, #6 and #10	1
53	358756	Clamp, hose, #6, 5/16"	53
54	358757	Clamp, hose, #10, 5/16".....	18
	870540	Parts Pack, 1009 Misc, Clamps.....	1
55	168695	Clamp, 1 1/4"	16
56	169339	Clamp, 7/8"	8
57	170496	Strap, boom-to-beta.....	1
58	179874	Beta sleeves 5/16" x 5/8"	7
59	171162	Strap, beta shorting for 3/4"	2
60	177888	Clamp, 3/4"	11
61	540087	U-bolt, 2 3/4", stainless steel.....	1
	870541	Parts Pack, 1009, #10 Hardware	1
62	500157	Bolt, #10-24 x 2", hex head, stainless steel	25
63	500159	Bolt, #10-24 x 1 1/2", hex head, stainless steel	1
64	504739	Bolt, #10-24 x 1 1/4", hex head, stainless steel	33
65	554071	Nut, #10-24, hex head, stainless steel	65
66	561178	Lockwasher, #10, split, stainless steel	38
67	565697	Lockwasher, #10, internal, stainless steel	67
	870542	Parts Pack, 1009, 1/4" Hardware	1
68	500156	Bolt, hex head, 1/4" x 3/8", stainless steel	20
69	504098	Bolt, hex head, 1/4" x 1 1/2", stainless steel	18
70	505266	Bolt, hex head, 1/4" x 3/4", stainless steel	130
71	505734	Bolt, hex head, 1/4" x 2 1/2", stainless steel	3
72	505763	Bolt, hex head, 1/4" x 1 3/4", stainless steel	5
73	506518	Bolt, hex head, 1/4" x 1 1/4", stainless steel	11
74	551367	Nut, square, 1/4", stainless steel	20
75	554099	Nut, hex 1/4", stainless steel	193
76	562961	Lockwasher, internal, 1/4", stainless steel	170

Parts List (continued)

Item No.	Part No.	Description	Qty
	870543	Parts Pack, 10009 Hardware, 5/16"	1
77	500349	Bolt, hex head, 5/16" x 5", stainless steel	5
78	500392	Bolt, hex head, 5/16" x 3", stainless steel	3
79	506966	Bolt, hex head, 5/16" x 2 1/2", stainless steel	2
80	506968	Bolt, hex head, 5/16" x 2 3/4", stainless steel	3
81	5142400	Bolt, hex head, 5/16" x 4", stainless steel	1
82	555747	Nut, hex, 5/16", stainless steel	13
83	564792	Lockwasher, split, 5/16", stainless steel	13
84	870544	1009 Boom Support Front Assembly	1
85	350846	Sleeve, Nicropress, 1/8"	4
86	351244	Chain link, open end, 3/16"	1
87	358731	Thimble, wire rope, 5/32", stainless steel	4
88	378216	Plate, 16 gauge, 5/8" x 2", punched, stainless steel	3
89	540093	Turnbuckle, end-to-end, #4, 1/4" x 4"	2
90	630009	Cable, galv. 1/8" dia, 15.750 ft.	1
91	870545	Boom, Rear Support Assembly	1
92	350846	Sleeve, Nicropress, 1/8"	4
93	351244	Chain link, open end, 3/16"	1
94	358731	Thimble, wire rope, 5/32", stainless steel	4
95	378216	Plate, 16 gauge, 5/8" x 2", punched, stainless steel	3
96	540093	Turnbuckle, end-to-end, #4, 1/4" x 4"	2
97	630009-1	Cable, galv. 1/8" dia, 13.750 ft.	1
98	872098	Boom, tube assembly	1
99	879915	BN 4000, UHF Connector	1
	879959	BN 4000, Type N Connector	1

Converting American Measurements To Metric

Use this scale to identify lengths of bolts, diameters of tubes, etc. The American inch (1") and foot (1') can be converted to centimeters in this way.

1 inch (1") = 2.54 cm

1 foot (1') = 30.48 cm

Example:

42" x 2.54 = 106.7 cm

FRACTION AND METRIC EQUIVALENT FOR ONE INCH			
FRACTIONAL INCH	MILLIMETERS	FRACTIONAL INCH	MILLIMETERS
1/16	1.599	9/16	14.288
1/8	3.174	5/8	15.875
3/16	4.700	11/16	17.463
1/4	6.350	3/4	19.050
5/16	7.937	13/16	20.638
3/8	9.525	7/8	22.225
7/16	11.112	15/16	23.813
1/2	12.700	1	25.400

