



308 Industrial Park Road
 Starkville, MS 39759 USA
 Ph: (662) 323-9538 FAX: (662) 323-

UB-7030SAT
 UHF 432 - 438 MHz
 Satellite Antenna

INSTRUCTION MANUAL

GENERAL DESCRIPTION

The Hy-Gain Model 70-30 SAT is a high-performance "OSCAR" (Orbiting Satellite Carrying Amateur Radio) satellite antenna for the 432-438 MHz frequency band. It features polarization switching circuitry for manual selection of either Right Hand Circular Polarization (RHCP) or Left Hand Circular Polarization (LHCP). This flexible design is suitable for worldwide applications with any of the amateur satellites having either an uplink or downlink in the 432-438 MHz frequency range such as AO-10, FO-12, AO-13, UO-14, AO16, LO-19, AO-21, UO-22, KO-23, etc. These include modes B, J, JA, JD, JL, L and S.

The 70-30 SAT antenna features 30 elements (total) on a 4.2 wavelength boom. Each set of 15 elements is designed to give 14.0 dBd gain based upon the NBS Tech Note 688. The 70-30 SAT also features high efficiency "Delta" matched driven elements for easy assembly and rugged durability. True RF 50 ohm switching relays are rated at 200 watts and contribute to improved VSWR. Feed points are encapsulated for long life in all types of climates.

Most hardware is stainless steel including the element pushnuts. All insulators are UV protected. The coaxial assemblies are made from high-quality Polytetrafluoroethylene (PTFE) dielectric and Fluorinated Propylene (FEP) jacketed coax cable.

The 70-30 SAT "OSCAR" antenna can be used with the Hy-Gain 216 SAT 2-meter "OSCAR" antenna and the 217S fiberglass 5 foot boom, or it can be used with other commercial or homebrew "OSCAR" antennas. The 70-30 SAT antennas may be stacked for more gain.

PREPARATION FOR ASSEMBLY

FOR OUR OVERSEAS CUSTOMERS: If you use the Metric System, see the American-to-Metric Conversion Table in the rear of this manual. Most illustrations in this manual will provide both American and Metric Dimensions.

Choose a moderate-sized clear area to assemble the 70-30 SAT Oscar Beam. The area must be at least 24" x 63" for each boom section.

SPECIFICATIONS

Mechanical

Boom Length	134 in. (340.4 cm)
Maximum Boom O.D.	1.125 in (28.6 mm)
Turning Radius (Max).....	71.25 in (181 cm)
Total Number of Elements	30
Longest Element	13 in. (33 cm)
Wind Survival	80 mph (128.7 km/h)
Mast/Boom Diameter Accepted	1.250 - 1.625 in (32 mm - 41 mm)
Wind Area	0.75 sq. ft. (.0697 sq. m)
Net Weight	4 lbs 14 oz (2.21 kg)
Stacking Distance (Min)	46 inches (1.17m) (1.7 wavelengths)

SPECIFICATIONS

Electrical

Frequency Range.....	432-438 MHz
Gain	14.0 dBdc
Beamwidth.....	28-30 degrees
Front-to-Back Ratio.....	25 dB
Ellipticity	3 dB Max.
Power Rating	200 W/PEP
Connector	Type N
Polarity Switch Voltage and Current Requirements	9-15 VDC @ 30-60 mA
VSWR (435-437 MHz)	Less than 1.5 when using fiberglass boom

A bench-vise with jaws no wider than 6 inches is recommended to hold the booms while the elements are being installed. An alternate method is to drive a 5' (1.5 m) length of mast material into the ground and attach the entire boom and boom-to-mast bracket to this mast temporarily during assembly. If you assemble this antenna over a grassy area, protection should be taken so that hardware is not accidentally lost during assembly. A concrete driveway is an excellent area for assembly.

Tools: The following tools are required for easy assembly of the 70-30 SAT OSCAR Beam:

QTY	Tool Type
1	Tape Measure, 12 ft.
1	Nut Driver, 1/2 in.
1	Nut Driver, 7/16 in.
1	Nut Driver, 3/8 in.
1	Nut Driver, 11/32 in.

A 3/8 inch by 6 inch tube (Item 35) is supplied to help install the insulators and pushnuts. Standard wrenches or adjustable wrenches may also be used in place of nut drivers.

When unpacking your antenna, check inside of all tubing for small parts and elements. To conserve space, these smaller articles are sometimes put inside larger pieces. Check all parts against the parts list in the rear of this manual to ensure no parts are missing.

Make all measurements to the given dimensions, plus or minus, no more than 1/16 inch! The assembly of this antenna will be easier if you read this manual completely through at least twice and follow the recommended directions. Allow at least 4 hours for assembly.

ASSEMBLY OF THE BOOM-TO MAST BRACKETS AND BOOM

Select the boom-to-bracket parts, boom sections and mast bracket parts as shown in Figure 1. Line-up the holes in the 3 boom sections as shown. The front and rear boom sections should meet at the center of the boom insert (Item 13).

NOTE: Another complete set of element mounting holes exist in the vertical plane and is not shown in Figure 1. This set has identical spacings between holes but is offset approximately 6 3/4 inches towards the rear of the boom assembly. This is 1/4 wave (90 degrees) at 435 MHz.

After assembly, the boom-too-mast bracket may be rotated on the boom so that after mounting, the elements are in an "X" configuration. Securely tighten the 1/4" - 20 x 3/4" hardware when the bracket is in the desired position. Securely tighten the #10 - 24 x 1 1/2" bolt which holds the coax support boom to the rear boom.

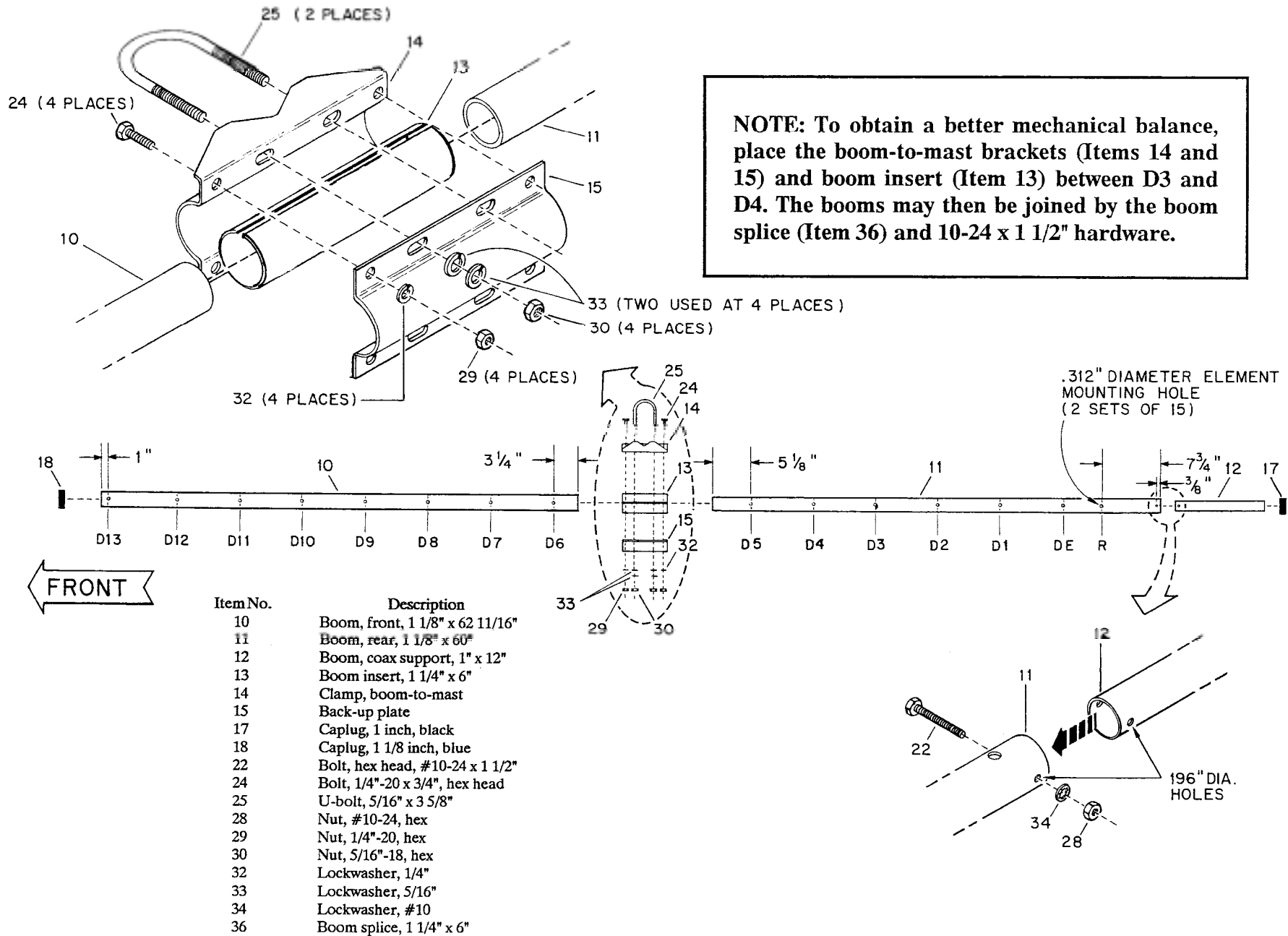

Figure 1
 Assembly of Boom and Boom-To-Mast Bracket

ASSEMBLY OF DRIVEN ELEMENTS

Select the two (2) driven elements, 3/16" x 12 1/4", marked with a single black color band need one end of each. Also select the insulators and pushnuts as shown in Figure 2.

Push one of the element insulators (Item 19) onto each Driven Element (DE) so that its shoulder is 5 9/16" from the nearest end (as shown in Figure 3). Insert the long end of each DE into the driven element mounting holes on the rear boom section, as shown in Figure 2.

Slide another element insulator (Item 19) over the other end of the DE's, and push it onto each element until it seats into the mounting hole. Recheck the exposed length of the DE's and reposition if necessary.

Carefully slip the 3/16 inch pushnuts (item 27) over each end of the two (2) driven elements, and push them along each element until they are snug against each element insulator. Check the exposed length of each DE during this process, to ensure the correct dimensions.

NOTE: You may wish to use the short length of tubing to help push the element insulators and pushnuts. If you accidentally slide a pushnut on too far, then you should cut it off the element and try again with one of the spare pushnuts.

Select the DE T-Bars (Item 20), and 3/16 inch tubing clamps (Item 21), and associated hardware. Assemble these parts to the driven elements as shown in Figures 3 and 4. When the coax assembly is installed later you will decide on either LHCP or RHCP for the unswitched polarization. See Figures 6 and 7.

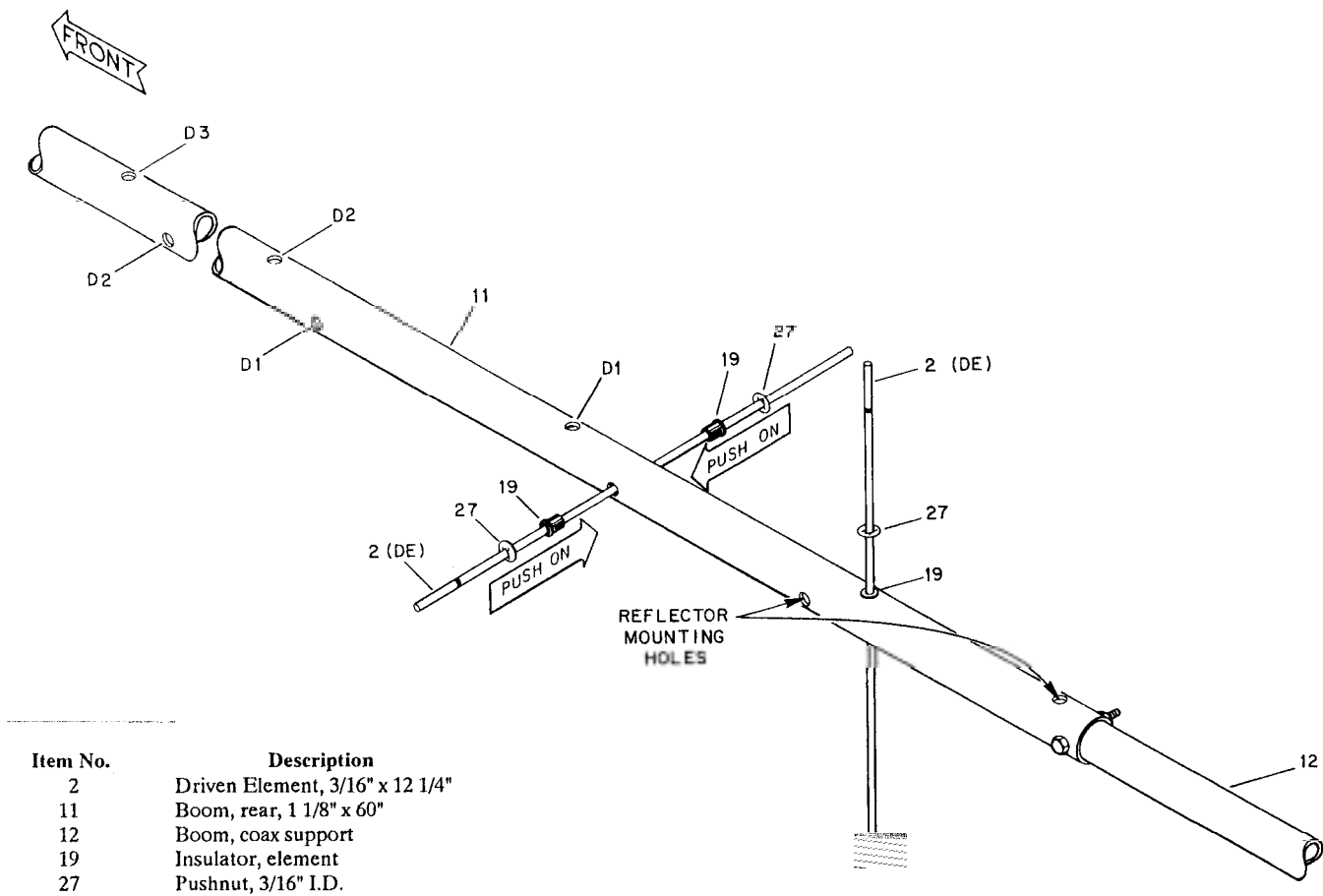
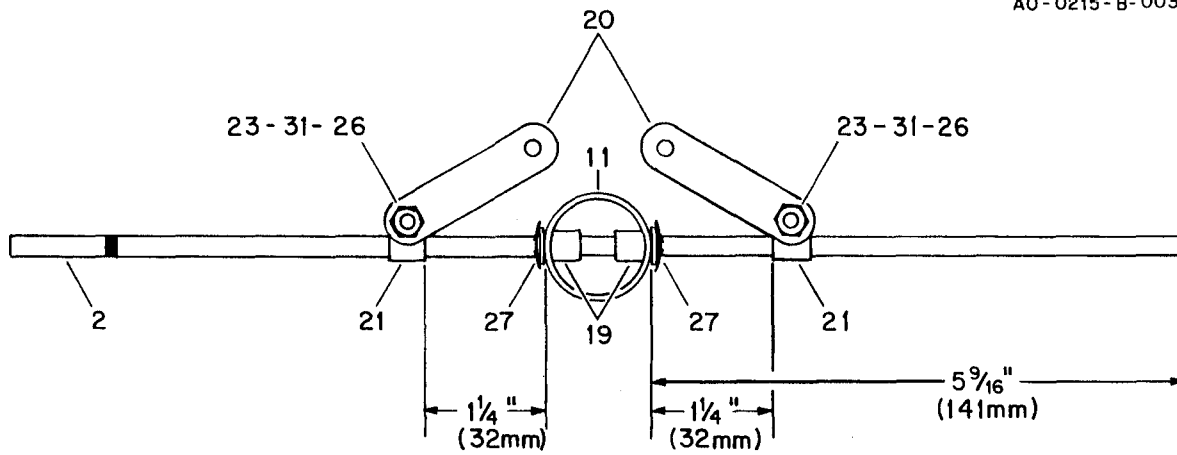
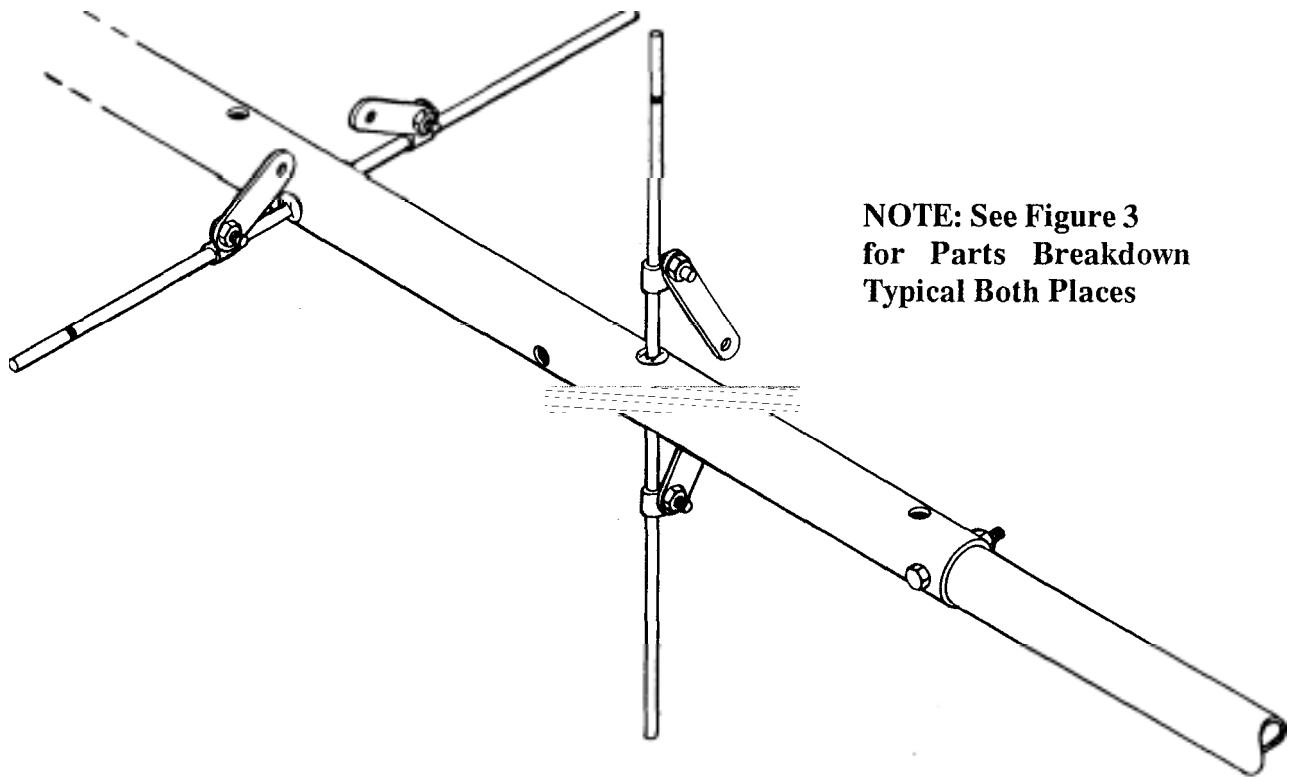

Figure 2
Driven Element Location and Assembly



Item No.	Description	Item No.	Description
2	Driven Element, 3/16" x 12 1/4"	23	Bolt, #8-32 x 1/2", round head
11	Boom, rear, 1 1/8" x 60"	26	Nut, #8-32, hex
19	Insulator, element	27	Pushnut, 3/16" I.D., stainless
20	Driven element, T-bar	31	Lockwasher, #8 internal
21	Clamp, 3/16" tubing		

Figure 3
Driven Element T-Bar Assembly



**NOTE: See Figure 3
for Parts Breakdown
Typical Both Places**

Figure 4
Orientation of Driven Element Connection

ASSEMBLY OF OTHER ELEMENTS

Select the two (2) reflector elements, 3/16" x 13", marked with two black bands near one end of each. Also select four (4) insulators and four (4) pushnuts.

Install the reflector elements in the reflector mounting holes as shown in Figure 2. Use the same methods as described for the driven elements along with the exposed length given in

Select one each of elements - D1, D2, D3, D4 and D5. Identify these elements by the length and color bands listed in Table 1. Install these elements on the rear boom section in the horizontal set of holes shown in Figure 1 and 2. Start with D1 adjacent to the driven element. Use the insulators and pushnuts and assemble in the same manner as described earlier.

Select one each of elements - D1, D2, D3, D4, D5, and D6. Install these elements on the rear boom section in the vertical set of holes shown partially in Figure 2. Start with D 1 adjacent to the horizontal driven element. Use the insulators and pushnuts and assemble in the same manner as described earlier.

Select one each of elements - D6, D7, D8, D9, D10, D 11, D12, and D13. Install these elements on the front boom section in the horizontal set of holes shown in Figure 1.

NOTE: The front boom section has 8 sets of holes in the "horizontal plane" and 7 sets of holes in the "vertical plane".

Select the remaining elements - D7, D8, D9, D10, D11, D12 and D13. Install these elements on the front boom section in the remaining holes in the vertical plane.

Item		Total Length		Exposed Length		Color	
No	Part No.	Element	Inch	Mm	Inch	mm	Band
1	160057	R	13	330	5 15/16	151	Black (2)
2	160058	DE	12 1/4	311	5 9/16	141	Black
3	160060	D1/D2	11 3/4	298	5 5/16	135	Brown
4	160061	D3	11 5/8	295	5 1/4	133	Orange
5	160062	D4	11 1/4	286	5 1/16	129	Yellow
6	160063	D5	11 3/16	284	5 1/32	128	Green
7	160064	D6	11 1/16	281	4 31/32	126	Blue
8	160065	D7	10 15/16	278	4 29/32	125	Violet
9	160066	D8-D13	10 13/16	275	4 27/32	123	(None)

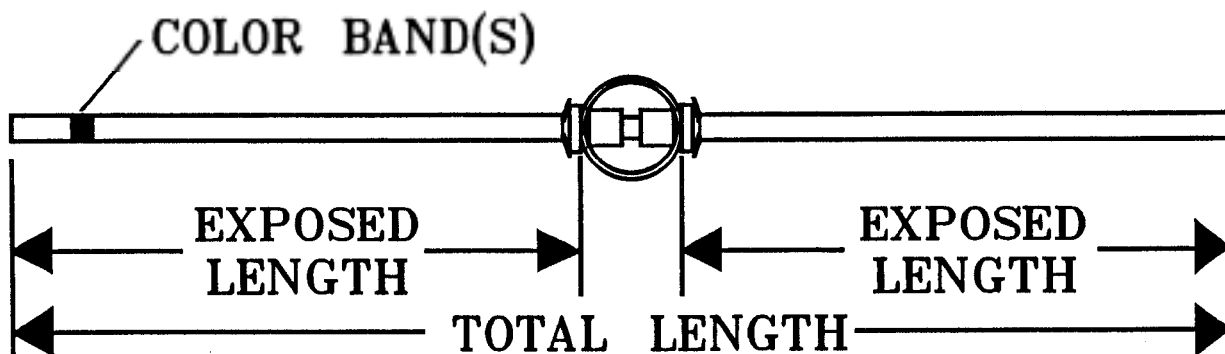

Table 1
Element Length & Color Band Identification

After the installation of all elements, check each exposed length from Table 1. Also check each set of 15 elements to make sure the elements are in the proper order. If any element has to be adjusted or moved, there are extra pushnuts supplied for partial reassembly.

ATTACHMENT OF COAX ASSEMBLY

Select the coax/circularity switch assembly (Item 16) and the remainder of the No. S hardware (Items 23,26 and 31). Attach one of the two sets of terminals to the front Driven Element's T-bars (Item 20) as shown in Figures 5 and 6.

Use black electrical tape, and secure this coaxial cable to the boom at two locations between the elements. See Figure 5.

The other coaxial cable coming from the coupler tube should make a single loop and its' terminals should attach to the rear DE's T-bars, as shown in Figure 5. Use black electrical tape to secure this coaxial cable,

NOTE: To achieve LHCP in the unswitched mode, the feedpoint solder lugs should be positioned as shown in Figure 6.

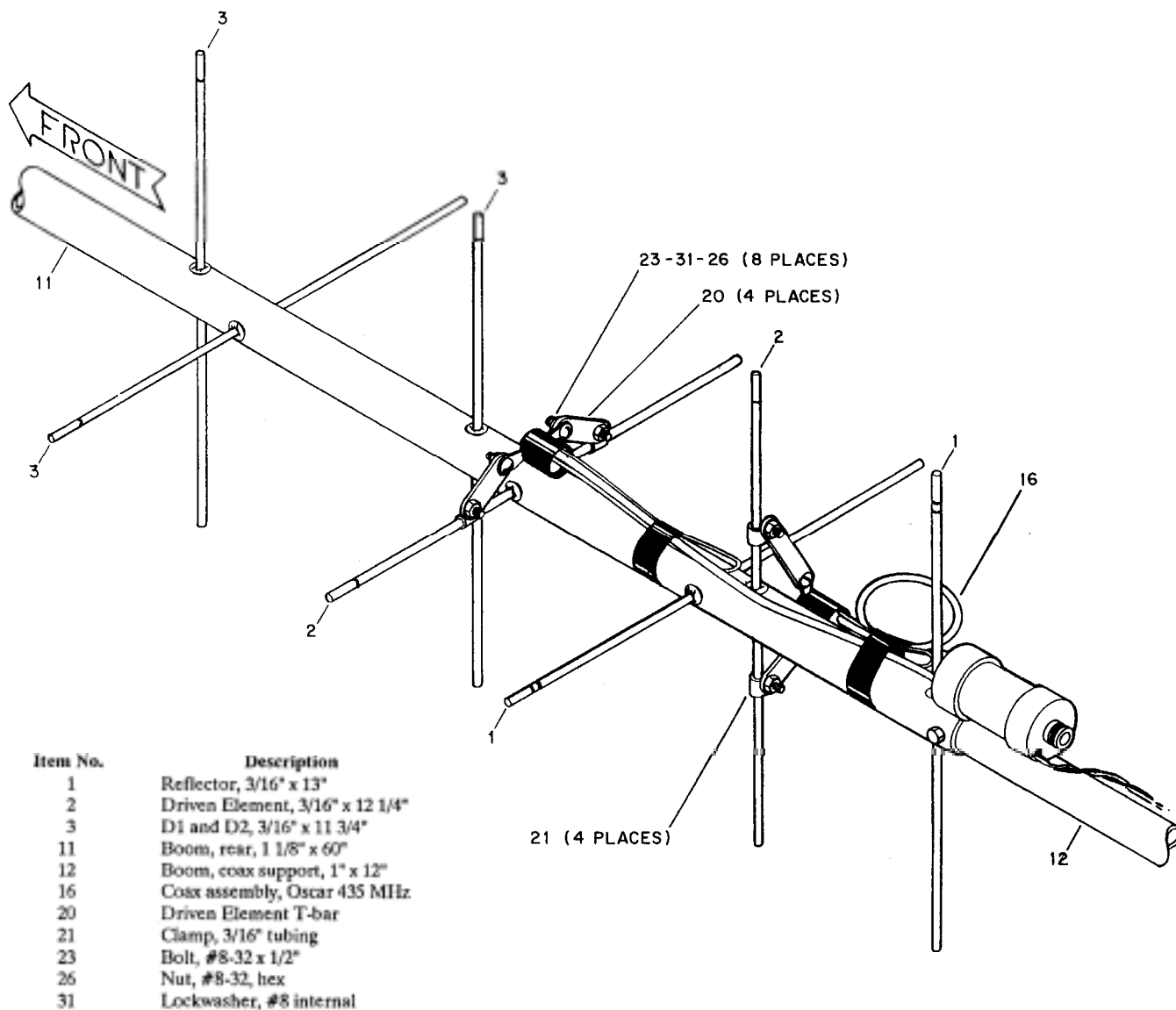
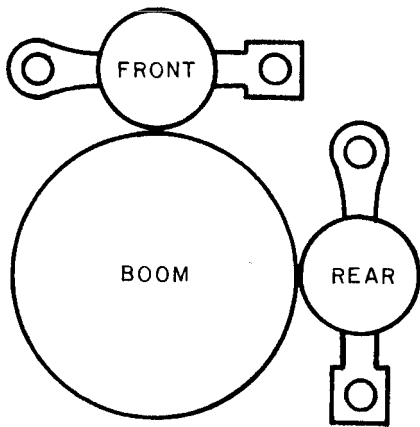
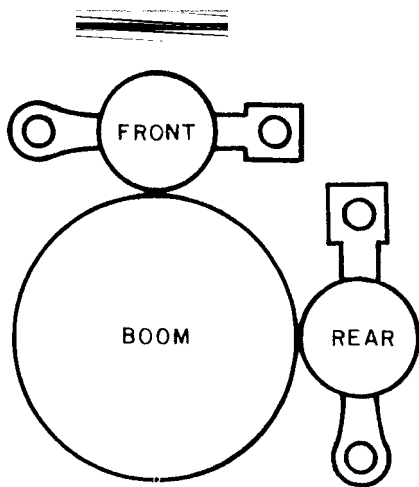

Figure 5
Attachment Of Coax Assembly



NOTE: Looking at rear end of boom and encapsulated feed points.

Figure 6
Feedpoint Orientation for LHCP
in the Unswitched Mode



NOTE: Looking at rear end of boom and encapsulated feed points.

Figure 7
Feedpoint Orientation for RHCP
in the Unswitched Mode

To achieve RHCP in the unswitched mode, the feedpoint solder lugs should be positioned as shown in Figure 7. The opposite polarization results when 9-15 volts DC is applied to the red and black wires. The black wire is at ground potential, and is directly connected to the shield of the coax, therefore a single wire may be used to switch this antenna if the minus (-) side of the switch power supply is connected to the shield of the coax in the shack.

Either LHCP or RHCP will result if these attachment procedures are not followed (random attachment). The opposite polarity results when switched. In no case, will linear polarity result if both Driven Elements are fed.

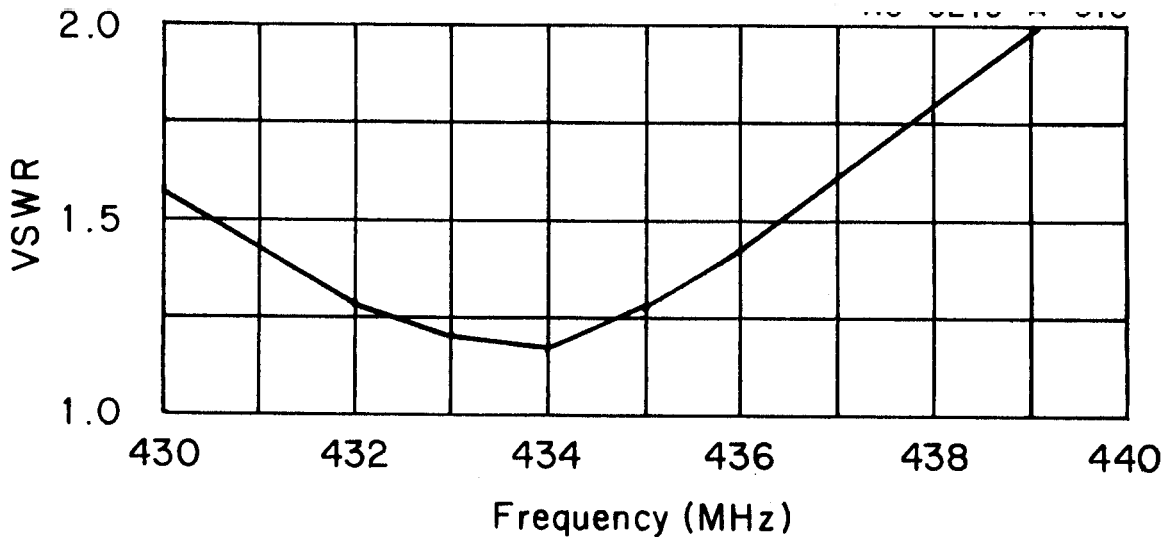

Table 2 VSWR Chart

INSTALLATION

The 70-30 SAT OSCAR-Beam may be centered mounted, and a fiberglass or other type of non-conducting boom must be used to achieve circular polarity. The boom-to-mast bracket will fit booms with 1 1/4" - 15/8" diameters.

The DC switching cables and feedlines must be routed off the rear of the boom to achieve circular polarity. A low loss cable such as Belden 8214 or 9913 should be used with Type N connectors.

WARNING:

DO NOT allow any part of the antenna to touch power lines. This could cause severe burns or fatal injuries.

When mounting the 70-30 SAT OSCAR Beam above any other antennas, allow at least 6 feet for clearance of the rear boom.

When mounting the 70-30 SAT OSCAR Beam on a common horizontal boom with other beams, allow at least 5 feet (center-to-center). The elements should be at a 45 degree angle with respect to the boom. This will minimize interactions between the antennas.

RAIN:

During and after a rain shower water droplets may collect on the elements. These droplets will cause the elements to appear electrically longer (lower in frequency) and may affect the gain and VSWR. You may wish to wipe any excess oil off the elements before assembly. This will help the elements shed water faster. Also, after a rain shower, rotate or shake the antenna to shake off the water droplets.

Service Information

If you are encounter technical problems and need assistance, you should contact Hy-Gain Customer Service Department.

All requests, inquires, warranty claims, or for ordering replacement parts, contact:

Hy-Gain

308 Industrial Park Road Starkville,
Mississippi 39759 USA Phone:
662-323-9538

PARTS LIST

Item No.	Part No.	Description	Qty
1	160057	Reflector, 3/16" x 13".....	2
2	160058	Driven Element, 3/16" x 12 1/4"	2
3	160060	D1, D2,3/16" x 11 3/4 ".....	4
4	160061	D3, 3/16" x 115/8 ".....	2
5	160062	D4, 3/16" x 11 1/4"	2
6	160063	D5, 3/16" x 113/16 ".....	2
7	160064	D6, 3/16" x 11 1/16"	2
8	160065	D7, 3/16" x 10 15/16"	2
9	160066	D8 - D13, 3/16" x 10 13/16"	12
10	173177	Boom, Front, 1 1/8" x 62 11/16"	1
11	173178	Boom, Rear, 1 1/8" x 60"	1
12	173179	Boom, coax support, 1" x 12"	1
13	173180	Boom insert, 1 1/4" x 6"	1
14	385142-1	Clamp, Boom-To-Mast	1
15	385144-1	Back-up Plate	1
16	877885	Coax Assembly, OSCAR 435 MHz	1
	877883	Parts Pack 215S - Insulators.....	1
17	450401	Caplug, 1 inch, black	1
18	450421	Caplug, 1 1/8" inch, blue	1
19	460337	Insulator, element	62
	877884	Parts Pack 215S - Hardware	1
20	173220	Driven Element T bar.....	4
21	358705	Tubing Clamp, 3/16 inch.....	4
22	500159	Bolt, #10-24 x 1 1/2", hex head	3
23	500185	Bolt, #8-32 x 1/2"	8
24	505266	Bolt, 1/4"-20 x 3/4", hex head	4
25	380809	U-bolt, 5/16" x 15/8.....	2
26	550063	Nut, #8-32 hex	8
27	550081	Pushnut, 3/16" I.D.	90
28	554071	Nut #10-24 hex.....	3
29	554099	Nut, 1/4"-20 hex	4
30	555747	Nut, 5/16"-18 hex	4
31	560035	Lockwasher, #8 internal.....	8
32	562961	Lockwasher, 1/4" internal	4
33	564792	Lockwasher, 5/16"	4
34	565697	Lockwasher, #10 internal	3
35	179720	Pushtube 3/8 x 6"	1
36	179728	Boom splice, 1 1/4" x 6"	1

METRIC

Converting American measurements to Metric:
 Using the scale below to identify lengths of bolts, diameters of tubes, etc. The American inch (1") and foot (1) can be converted in this way.

$$1 \text{ inch (1")} = 2.54 \text{ cm}$$

$$1 \text{ foot (1)} = 30.48 \text{ cm Example:}$$

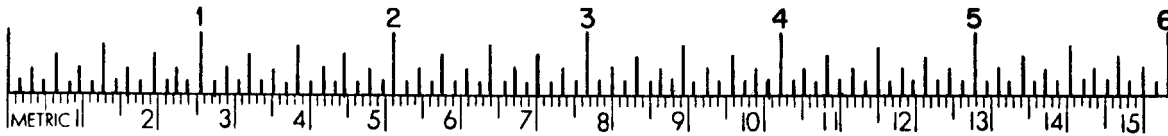

FRACTION AND METRIC EQUIVALENTS FOR ONE INCH			
Fractional Inch	Millimeters	Fractional Inch	Millimeters
1/16	1.588	9/16	14.288
1/8	3.175	5/8	15.875
3/16	4.700	11/16	17.463
1/4	6.350	3/4	19.050
5/16	7.937	13/16	20.638
3/8	9.525	7/8	22.225
7/16	11.112	15/16	23.813
1/2	12.700	1	25.400

Table 3 Fraction and Metric Equivalents For One Inch

hy-gain® LIMITED WARRANTY

Hy-Gain Warrants to the original owner of this product, if manufactured by **Hy-Gain** and purchased from an authorized dealer or directly from **Hy-Gain** to be free from defects in material and workmanship for a period of 12 months for rotator products and 24 months for antenna products from date of purchase provided the following terms of this warranty are satisfied.

1. The purchaser must retain the dated proof-of-purchase (bill of sale, canceled check, credit card or money order receipt, etc.) describing the product to establish the validity of the warranty claim and submit the original or machine reproduction of such proof of-purchase to **Hy-Gain** at the time of warranty service. **Hy-Gain** shall have the discretion to deny warranty without dated proof-of-purchase. Any evidence of alteration, erasure, or forgery shall be cause to void any and all warranty terms immediately.
2. **Hy-Gain** agrees to repair or replace at **Hy-Gain's** option without charge to the original owner any defective product under warranty, provided the product is returned postage prepaid to **Hy-Gain** with a personal check, cashiers check, or money order for \$8.00 covering postage and handling.
3. Under no circumstances is **Hy-Gain** liable for consequential damages to person or property by the use of any **Hy-Gain** products.
4. Out-of-warranty Service: **Hy-Gain** will repair any out-of-warranty product provided the unit is shipped prepaid. All repaired units will be shipped COD to the owner. Repair charges will be added to the COD fee unless other arrangements are made.
5. This warranty is given in lieu of any other warranty expressed or implied.
6. **Hy-Gain** reserves the right to make changes or improvements in design or manufacture without incurring any obligation to install such changes upon any of the products previously manufactured.
7. All **Hy-Gain** products to be serviced in-warranty or out-of-warranty should be addressed to **hy-gain, 308 Industrial Park Road, Mississippi 39759, USA** and must be accompanied by a letter describing the problem in detail along with a copy of your dated proof-of-purchase.
8. This warranty gives you specific rights, and you may also have other rights which vary from state to state.