

**INSTRUCTION MANUAL  
FOR THE  
ISOTRON 40**

MANUFACTURED BY  
BILAL COMPANY  
137 MANCHESTER DR  
FLORISSANT, CO. 80816  
PH: 719/687-0650

## TABLE OF CONTENTS

ASSEMBLY FOR THE ISOTRON 40	2
TUNE UP	4
WARRANTY	5
FINDING THE RESONANT POINT	7
TRIMMING THE COIL	9
COMPENSATION FOR VARIATION IN LOCATION	10
SIDE TOWER MOUNTING	12
GROUNDING	12
USE OF A TUNER	13
POWER RATING	15
SINGLE FEEDLINE OPERATION	16
PERFORMANCE	17

## ASSEMBLY FOR THE ISOTRON 40

Parts List: (Please locate all parts prior to assembly.)

1. Top Plate
2. Bottom Plate with connector.
- 3 & 4. Acrylic Insulators 2" x 7".
- 5 & 6. Top and Bottom Non-Metallic Supports.
7. Coil Assembly.
- 7a. Two 1/4" Diameter Coil Support Rods. coil.
8. Lead wire, attached to the bottom of the coil.
9. 1/4" Diameter Tuning rod (90 deg. bend).
10. Capacitor Hat for the tuning bar.
11. Grounding wire.

### ASSEMBLY:

1. Bolt the Top Plate (1) to the Top Support (5). Use 1 1/2" x 1/4" machine bolt through the rear hole. Leave the front hole open (see figs. 1 & 2, Pg. 6)
2. Bolt the Bottom Plate (2) to the Bottom Support (6). Use a 1 1/2" x 1/4" machine bolt through the rear hole. Leave the front hole open.
3. Bolt both Acrylic Insulators (3 & 4) to the Top Plate (1). Use three 3/4" x 1/4" machine bolts and nuts. Leave a hole open toward the front of the antenna opposite the side of the connector. The small threaded holes in the Acrylic Insulators should be placed away from the Top Plate. (see fig. 2, pg. 6)
4. Bolt the Bottom Plate (2) to the opposite ends of the Acrylic Insulators (3 & 4) Using four 3/4" x 1/4" machine bolts.
5. Thread four stop nuts onto the ends of the Coil Support Rods (7a). There should be one stop nut on each end. (see fig. 1, pg. 6)
6. Thread one Coil Support Rod into the bottom of the Coil and tighten it. A minimum of 3/4" of thread needs to go into the coil.

### 3.

7. Slip one end of the second Coil Support Rod through the wire eye at the top of the Coil. Thread a second stop nut onto the end of this Coil Support Rod to secure the wire eye. Thread this Coil Support Rod into the top of the Coil and tighten (at least 3/4" in). Then tighten the second nut to secure the wire eye. (see fig. 1 pg. 6)

8. Mount the entire Coil Assembly (7,7a) to the Top and Bottom Plates (1 & 2) by putting the Coil Support Rods through the front holes in the Top and Bottom Supports. Use one flat washer against the stop nut at the top. Tighten until snug with a 1/4" nut.

9. Slip the wire eye of the Grounding Wire (11) onto the rear bolt on the Bottom Support. Thread a second hex nut onto the rear bolt and tighten to hold the Ground wire in place. (see fig. 4, pg. 6)

10. Slip the small wire eye from both lead wires coming from the Coil and connector onto the 8/32 x 1/2" machine screw and thread the screw into the hole in the nearest Acrylic Insulator. (see fig.1, pg. 5) Tighten securely.

#### SETUP:

1. For best performance the antenna should be mounted as much in the clear as possible and as high as possible. Mount the antenna on a standard TV type **METAL** mast by sliding the U-Bolt assemblies over the end of the mast and tightening the hex nuts. Put the free end of the Ground Wire (11) over the nearest end of the U-Bolt before tightening the hex nut on that end. Align supports 5 & 6 so they are parallel. (see pg. 14) Square the antenna up and tighten the U-Bolts securely.

2. A coaxial feedline of 50-75 ohms should be connected to the coaxial connector. The coax should be taped to the metal mast or secured with standoffs. Make a neat coax run to your radio.

**PLEASE NOTE:** Lengths of coax that are an exact 1/4 wavelength should be avoided. This length would have the velocity factor considered for your type of coax. This is only for the first 1/4 wavelength. Adding a few feet of coax to avoid this length is fine.

3. The Tuning Rod (9) should not be mounted at this time.



## TUNE UP:

1. The antenna support (Metal Mast) should have a good earth ground (outdoor installation). Please refer to the section on **GROUNDING**.
2. The antenna is ready for testing. Using the least amount of power your SWR meter will operate at, check or graph the SWR across the band. **THE LOWEST SWR IS YOUR RESONANT POINT.**
3. In most cases this is all that is needed for the Tune Up. Please refer to pages 7, 8 and 9 on "**FINDING THE RESONANT POINT**" if further diagnosis is needed to find the minimum SWR.
5. If a lower Resonant Point is desired, then you can add the Tuning Rod (9). Put a stop nut on the short threaded end. Then insert in the remaining hole of the Top Plate. (Fig. 3 pg. 6)
6. The frequency adjustment is simply a rotation of the Tuning Rod (9) from straight up (highest resonant point in frequency) to straight down (lowest resonant point), rotating toward the front of the antenna.
7. If a lower range of Resonant Frequencies are needed, then you can add the hat (10). Put a stop nut first, the hat, then a second nut to the tuning bar (9). See figure 3, page 6.
8. There should be no matching devices in the line for the initial tune up. However a Matching device is highly recommended for the solid state radios once the Tune Up is complete.
9. Use the least amount of power your SWR meter will operate at for a more precise reading.
10. If tuning becomes complicated due to your environment, then refer to the pages titled, **FINDING THE RESONANT POINT** and **COMPENSATION FOR VARIATION IN LOCATION**.
11. If your installation is restricted to balcony, indoor or attic locations, then it is best not to attempt grounding the Metal Mast. The Isotrons were designed to be used with a metal mast. Even an indoor installation should have a Metal Mast even if it is a short one and the coax taped to it.
12. If the Isotron 80 is used, it can be mounted on the same mast at the same height and one feedline is needed. The two antennas are connected in parallel using a coaxial "T".

### **WARRANTY**

**Bilal Company warrants this equipment against defects in material and workmanship for a period of one year from the date of original purchase.**

**This warranty is limited to replacing or repairing the defective parts and is not valid if the equipment has been tampered with, misused or damaged.**

**NOTE: Do not ship to the factory without prior authorization. First write and describe the difficulty. Many time we can diagnose and correct problems by mail.**

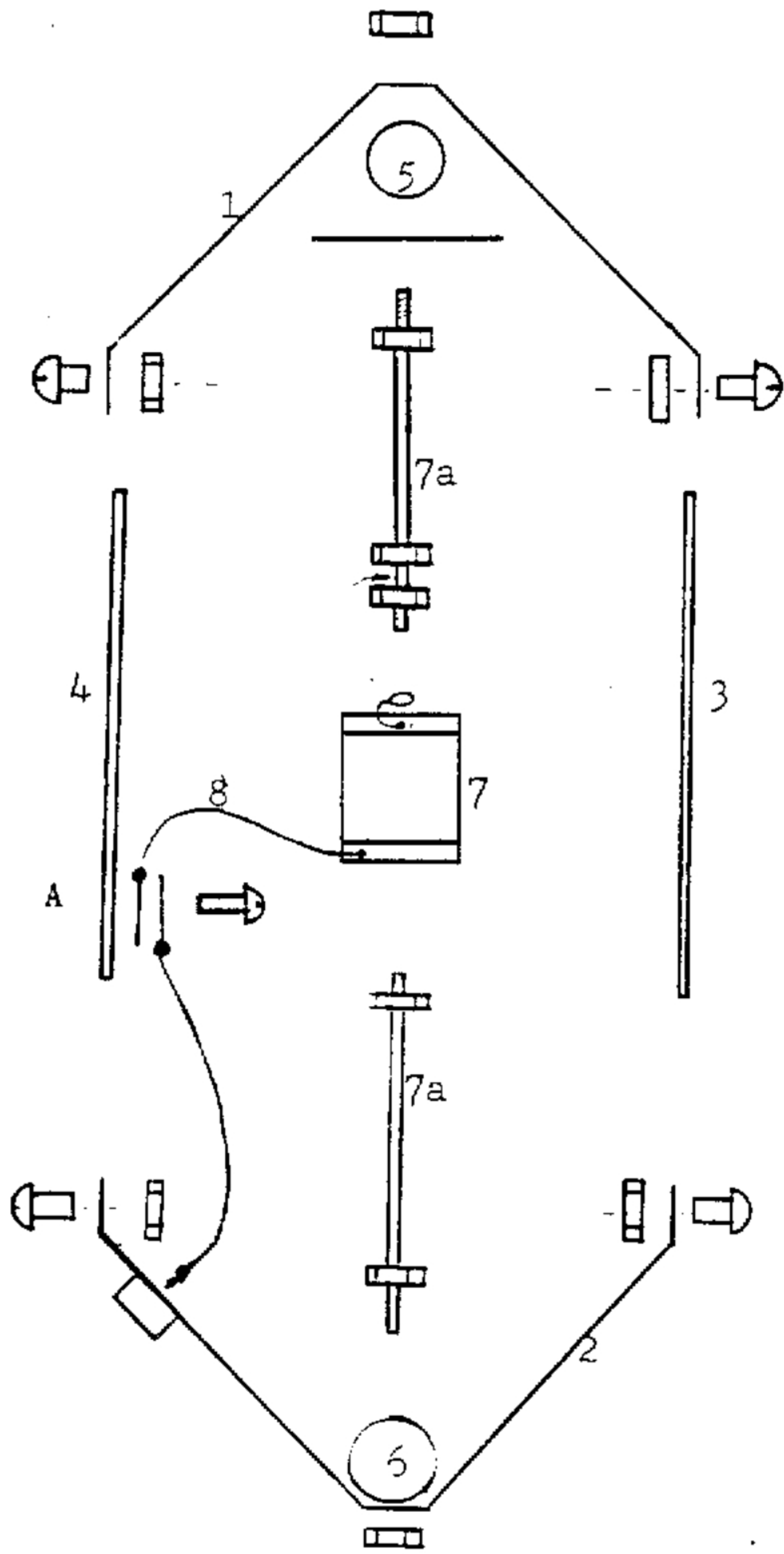

Figure 1

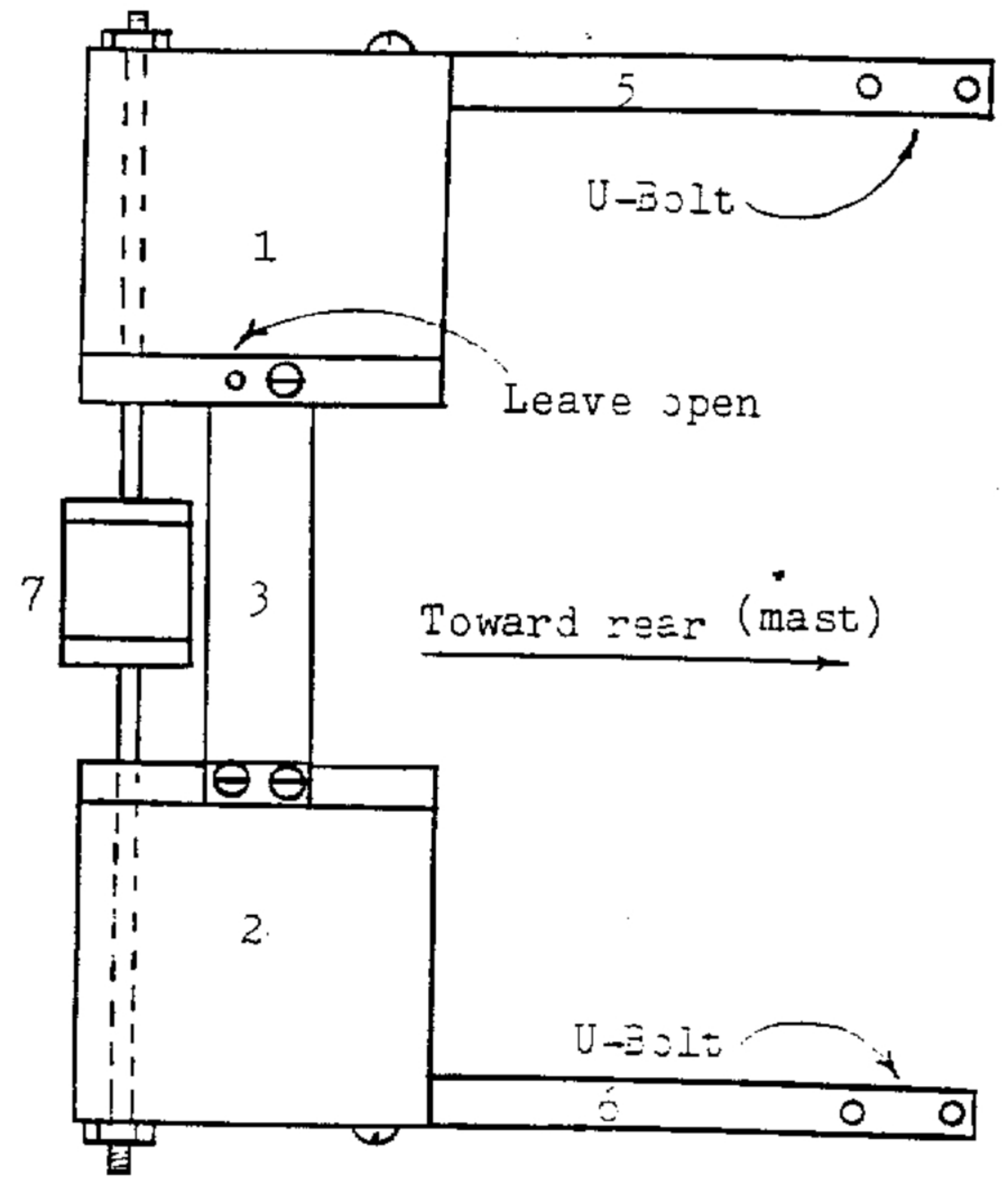

Figure 2

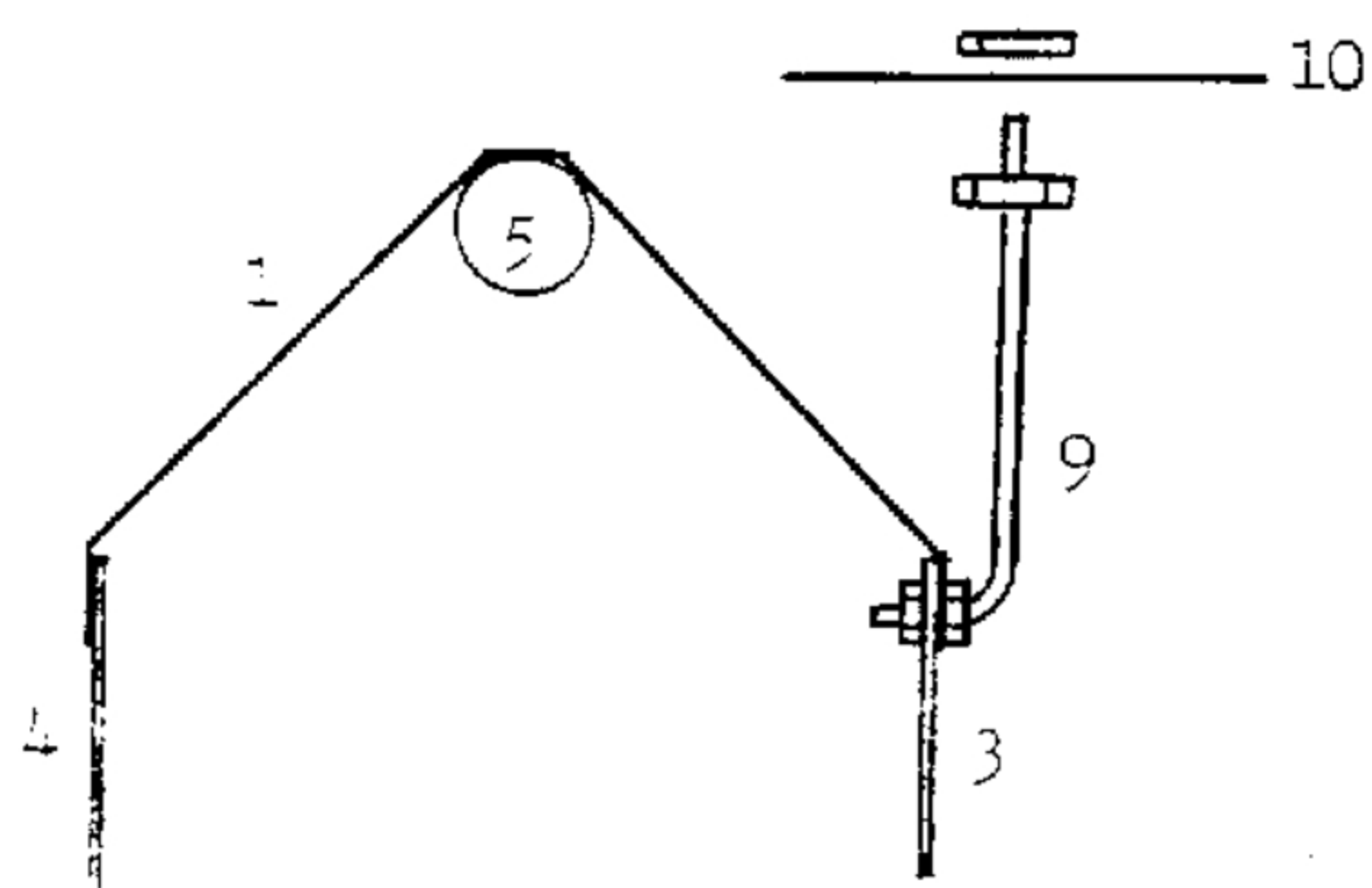

Figure 3

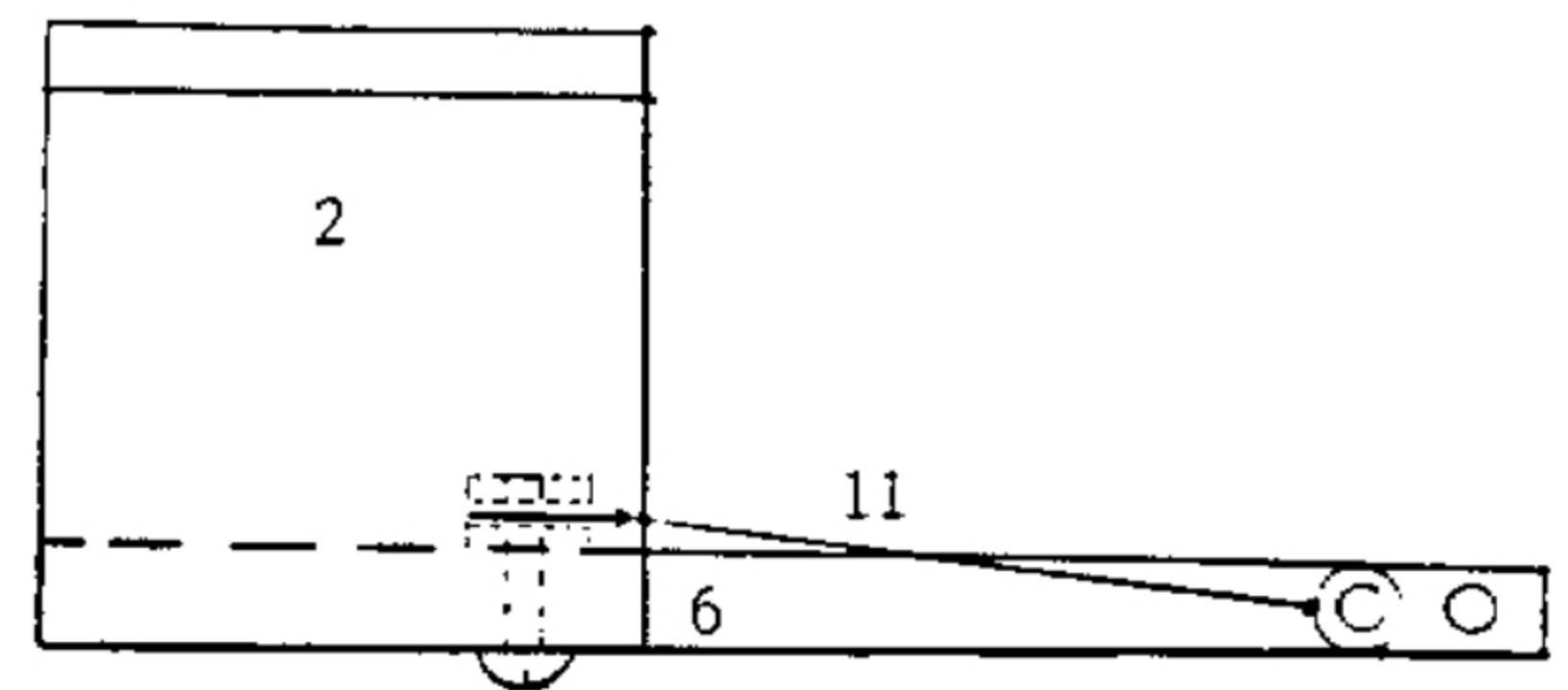

Figure 4

Not to scale.



## FINDING THE RESONANT POINT

1. Locating the resonant point is the major part of the tune up. The following steps is a reliable technique for locating the resonant point.

**2. IF YOUR SWR IS OVER 3:1, IT IS A RESONANT POINT ADJUSTMENT THAT NEEDS TO BE MADE.**

3. You will need a SWR meter. You will also need to hear the receiver from the antenna location.

4. Connect the antenna to your transceiver by means of a suitable length of coax. NEAT RUNS AND INSTALLATIONS ARE VERY IMPORTANT.

5. Tune your receiver to the frequency desired.

6. Listen to the Noise/Signal at this frequency.

7. Bring your hand toward the top plate of the antenna.

8. Carefully listen. If the Noise increases at some point while your hand is approaching the Top Plate, then the resonant point is higher than the frequency you are set at.

9. You will need to make the necessary adjustments to lower the resonant point of the antenna. (Rotating or adding hardware.)

10. If the Noise decreases only while bringing your hand toward the Top Plate, then the antenna is resonant at a lower frequency than the receiver is tuned.

11. If the antenna resonant point is low, it is best to start at the lowest frequency available to you. Check it again with your hand. This technique for determining the resonance is very reliable. It is not necessary to spend a lot of time guessing where the antenna is resonant. Continue this procedure through the following steps as a reliable resonant point check.



8.

12. If the resonant point is low, it will be necessary to remove all tuning hardware to bring the resonant point to maximum. It is possible for your environment to make the antenna resonate below the designed band.

13. If the test shows the antenna is resonant lower than you desire or below the band, then tune your receiver to the lowest frequency available to you. Check the SWR as in the next step.

14. SWR should be checked at the lowest power that the meter will read. The sensitivity control should be all the way up and the meter calibrated by the gain on the exciter.

15. Note the SWR at the lowest frequency. Then move up 25 khz and check the SWR again. Continue to do this until you can see a pattern.

16. If the SWR increases as you move up frequency, then the resonant point is below the band or minimum frequency. Trimming the coil may be necessary. (See page 10.)

17. The object is to locate a minimum SWR by graphing as described in step 15.

18. If you have a general coverage receiver you can listen at a lower frequency and check the antenna with your hand as described.

19. Once your resonant point is located in your operating area, your SWR will make a noticeable dip (below 3:1). Unless your environment interaction is very strong, this normally produces a low and acceptable SWR.

20. If you are using a Noise Bridge, it should be located near the antenna for tune up.

21. Impedance may be adjusted if necessary after completion with the resonant point. This is described on pages 11 and 12.

### TRIMMING THE COIL

For specific frequencies such as for MARS, CAP, FAA and so on where frequencies near, but not in the amateur band are required, coil trimming may be done to reach those frequencies. In cases of extreme environment interaction, trimming may be necessary for proper resonant point.

Before trimming the coil, the antenna must either be properly operating at some point on the band being used, or you have confirmed the resonant point is lower than where your operating. DO NOT TRIM THE COIL PRIOR TO THIS.

Remove all the tuning hardware and take note of where the resonant point is. Trimming will be from this point, therefore the tuning hardware could be used for lowering the resonant point to where desired.

1. Remove the Top Coil Support.
2. Tape the coil securely so the windings will unravel.
3. Clip the eye on the top lead of the coil.
4. Slide the wire back through the two holes in the coil form.
5. REMOVE 1/2 TURN AT A TIME! Slip the wire back through the two holes from the opposite direction. Looking through the hole as the wire comes to you will help line it up.
6. Reconnect the wire to its original position and trim the excess.
7. Check your resonant point. If needed repeat the procedure as many times as necessary in 1/2 turn increments.



### COMPENSATION FOR VARIATION IN LOCATION

The antenna-to-ground capacitance of your ISOTRON antenna depends on its location with respect to other objects and to the ground itself, and how and where it is mounted. Antenna-to-ground capacitance affects resonant frequency and feed-point impedance of your antenna.

For example, if the ISOTRON is mounted on a tower, somewhere near the middle, its resonant frequency and impedance value will be lower than if the antenna is mounted in the clear. By insulating the antenna from the tower, you can increase its feedpoint impedance and raise its resonant frequency. Different locations on the tower will produce different values, and it may be necessary to compensate differences by tuning your ISOTRON. If the feedpoint impedance and resonant frequency become higher than desired, then it is possible to decrease them by connecting a capacitor of about 100pf or less between the antenna and the tower (see pg. 14, fig. 2). Another words the lowest impedance would be directly grounding the antenna to the mast. A point in between can be obtained by the use of a capacitor as described. This technique will apply on most mountings where the feedline is longer than 1/8 wavelength. If the feedline is shorter, then the impedance value is determined by the ground of the radio and cannot be varied.

It is important to know what the value of the impedance will be at resonance, and what the resonant frequency of the antenna is. An impedance bridge (Noise Bridge) is a very good way to make these measurements, and can be a valuable investment for the radio operator. A Noise Bridge is quite inexpensive, and enables you to make the measurement quickly, simply and accurately.

If a Bridge is not available, then a little guess work will tell the story. Once you located the resonant point and put it where you want, your SWR should be no higher than 3:1 at a low power reading. The antenna should be grounded to the mast when determining resonant point. Release the grounding wire (11). Check the SWR. The resonant point may move up a little and will have to be relocated.

Attic and top-of-building mounting where your ISOTRON cannot be easily grounded, could produce a feedpoint impedance of as much as 200 ohms. It is desirable to ground your antenna to a good earth ground, but if this is not possible, then the next best thing is to use the ground in your electrical system. This is attached to your outlets where the third prong would insert on some appliances. The ground wire should be attached to the bottom of the mast only where the antennas are mounted. Please note that the shield of the coax is not considered to be the same ground as the grounded components of the antenna, such as mast or bottom plate.

The diagram on page 14 shows how to insulate your antenna from ground if necessary and how to connect the mica or ceramic capacitor for values in between.

One factor to consider is the environment interaction when transmitting at various power levels. The instructions on page 8 call for tuning at a minimum power level. In some very tight or highly conductive surroundings (metal sidings, machinery, etc.) an increase in SWR from the low power to the high power setting will be indicated. This can be compensated for by relocating the antenna. If this is not practical a tuner can clean this up. (See the sheet on USE OF A TUNER)



### SIDE TOWER MOUNTING

The antennas should be offset from the tower. This can easily be done with a 5 or 10 foot mast mounted across the legs of the tower. The Isotrons can be mounted horizontally on the mast. A light nylon cord could be attached to the mast and back to the tower at a 30 to 45 degree angle to keep the mast from drooping.

### GROUNDING

There is much confusion about grounding antennas. The Isotrons do not use a ground for performance. Grounding offers a change in impedance value as well as protection against static discharge.

The ONLY way to ground the Isotrons is by connecting the ground wire to the bottom of the mast the antenna is mounted on.

NEVER run a ground wire up to the antenna. The wire will interact with the feedline and drastically change the tuning. Avoid running ground wires parallel to the feedline if possible.

The Ground wire should be as short as possible and as direct as possible to the grounding point.

Excessive Ground Wires may cause more problems than if they were not used at times.

### THE USE OF A TUNER

The instructions provided basically discourage the use of a Tuner. This is for the purpose of initially tuning up the antenna. However there are times when a tuner has its place.

With the increasing popularity of solid state transmitters a tuner is almost a must. Back in the days when tube finals were used the manufactures automatically provided the tuner. Since the solid state circuits have become popular, they have left the tuners out. This makes it a must for an antenna system to be very critically tuned so the exciter will not cut back its power. In many cases this is very impractical and the use of a tuner can be a good asset to your set up.

In tight locations or locations not favorable for an antenna installation, the impedance of the antenna may not adjust to the 50 ohms needed. An installation indoors with a very short feedline may keep the impedance lower than 50 ohms. The recommended adjustments may have little affect due to the short feedline. At the lowest the antenna will exhibit a 20 ohm impedance, giving a SWR of around 3:1. Please keep in mind that if your SWR is over 3:1 the problem is your resonant point, not impedance value. This can be corrected by following the instructions on **RESONANT POINT.**

If you find isolating the antenna from ground does little to raise the impedance due to your location, then the tuner can be used to match the exciter to the antenna. This will not sacrifice performance if done correctly.

Expanding bandwidth is another asset of the tuner. To avoid retuning the antenna for different parts of the band a tuner can be used to flatten the line and make it acceptable to the exciter.

In conclusion, tuners can be used if not abused in your installation. Under a conventional installation the Isotron will tune up directly, but many operators have to operate in less than ideal circumstances. The Isotron was intended for this challenge and we will be willing to help you with it.

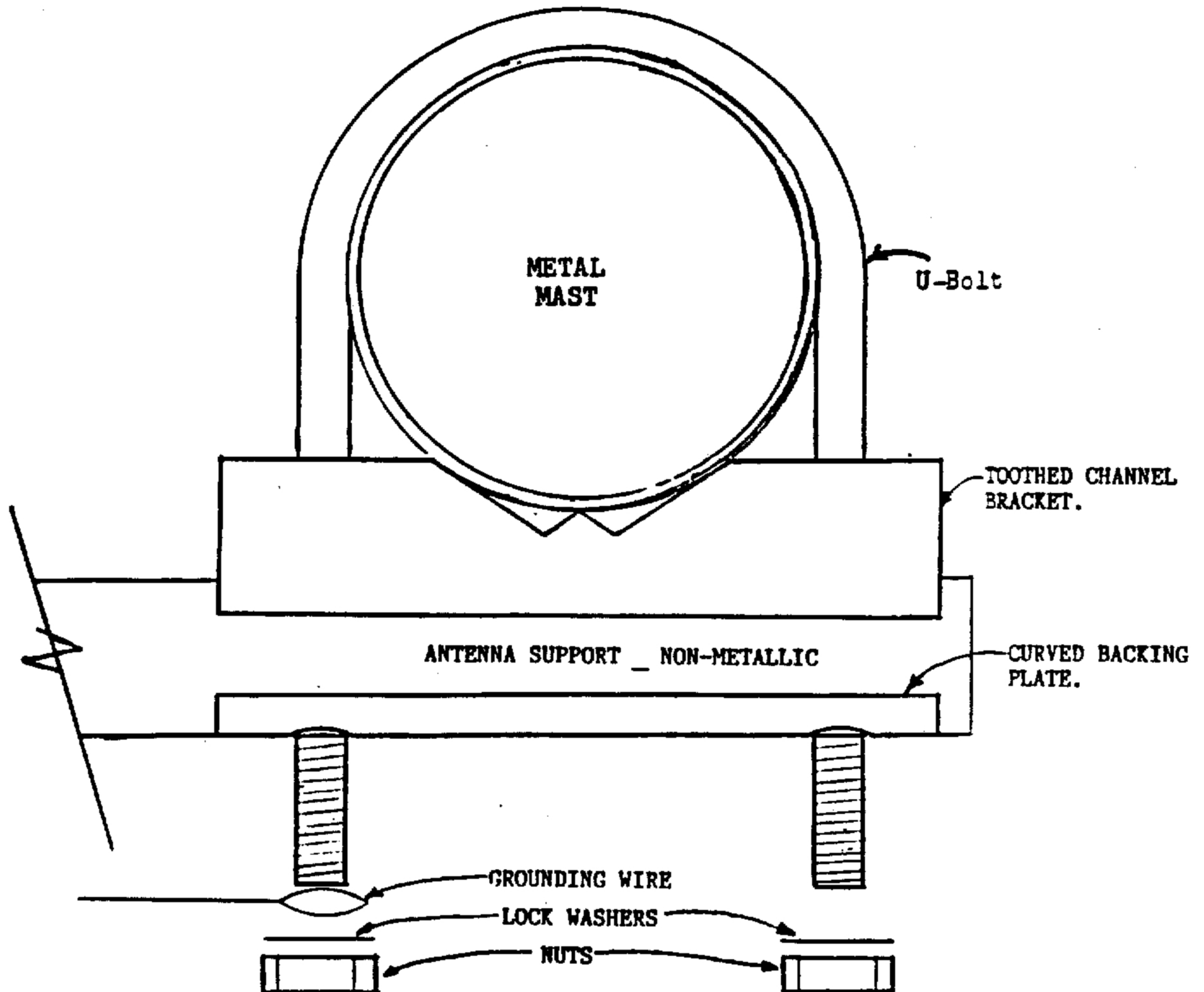

Remove "GROUNDING WIRE" for higher impedance value. See section titled "COMPENSATION FOR VARIATION IN LOCATION".

"GROUNDING WIRE" may be cut to splice a capacitor in place for impedance values between the high and low values. 100 pf or less for 80 - 10 meters. 1,000 pf for 160 meters.

### POWER RATING

The power rating defined in the catalogue is INPUT POWER. This is how many exciters are rated. However, some exciters or amplifiers are rated in OUTPUT POWER.

The Isotrons are intended to handle outdoors 1,000 watts PEP or 500 watts CW into the antenna. Indoors the rating is 500 watts PEP or 250 watts CW into the antenna.

**YOU SHOULD MONITOR YOUR SWR AT ALL TIMES WHEN USING HIGH POWER.**

**IF THE SWR IS UNSTABLE OR SLOWLY INCREASES WHILE TRANSMITTING, CUT BACK YOUR POWER IMMEDIATELY UNTIL IT STABILIZES!**



### SINGLE FEEDLINE OPERATION

The Isotrons have been designed so they can be mounted back to back. As many as three can be mounted this way around a mast at the same height.

Electrically the antennas can be fed with one feedline by simply connecting them in parallel. Three antennas of any band you desire work well on one feedline. There is no limit to how many you can put on a single coax. However, the more you connect over three the more complicated the match becomes. An electrical diagram is shown below.

With antennas mounted back to back, a coaxial "T" is connected to the antenna of the highest band. This is done by either the male side of the "T" or by a short jumper from the female side. The remaining connection will jumper over to the next highest frequency antenna. If there is a third antenna, then the procedure is repeated again.

Tune up is the same for the resonant point as in the individual antennas.

Impedance value becomes the average of all of them. Therefore if you isolate one antenna from ground, you must isolate all of them. What you do with one antenna for impedance you do with all of them. You can see if you have over three it can get quite complex and the aid of a Noise Bridge will be a big help.

CONFIGURATION OF THREE ANTENNAS ON ONE FEEDLINE CONNECTED IN PARALLEL.

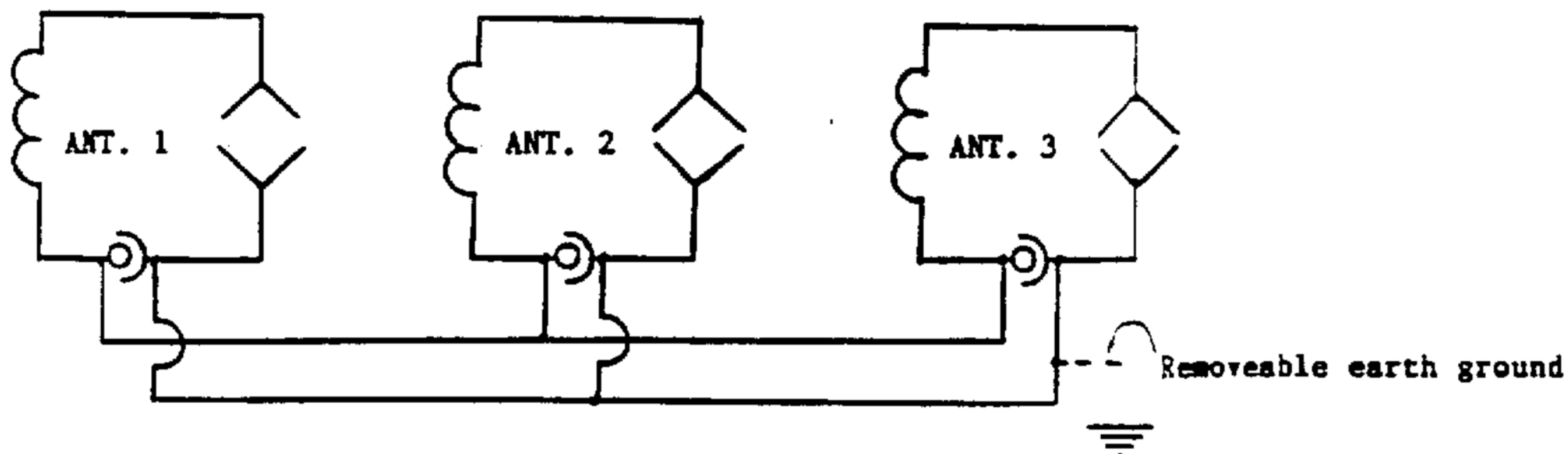

## PERFORMANCE

What makes the Isotron Antennas perform?

Starting from the exciter, RF must be delivered to the antenna. This is done through your feedline. Next, the RF energy needs to be radiated into space. This is accomplished by terminating the feedline with a radiating resonant circuit - the antenna. Contrary to popular opinion, the impedance match has very little affect on performance of the antenna. A mismatch of up to 6:1 SWR will still provide performance that compares to a 1:1 SWR.

This is not to be confused with the exciter protection circuit that reduces power output. Many solid state exciters have their power reduce at a 1.5:1 SWR. This situation can be overcome by using an outboard tuner.

In most cases a 1:1 SWR can be achieved with the Isotrons. None-the-less, it may be difficult to achieve the ideal antenna match when operating in very tight locations. The antennas radiation will still be optimum as long as you adjust the resonant point. The resonant point can be adjusted in any location regardless of how tight the installation is. The radiation performance can easily be checked by a simple Field Strength test, either using a Field Strength meter or another local station close by.

Once your Isotron is at the resonant point, radiation is at the mercy of the environment. Height enhances your performance best so do not sacrifice height if you have a choice. Isotrons are designed to mount high on a light mast so take advantage of this feature.