

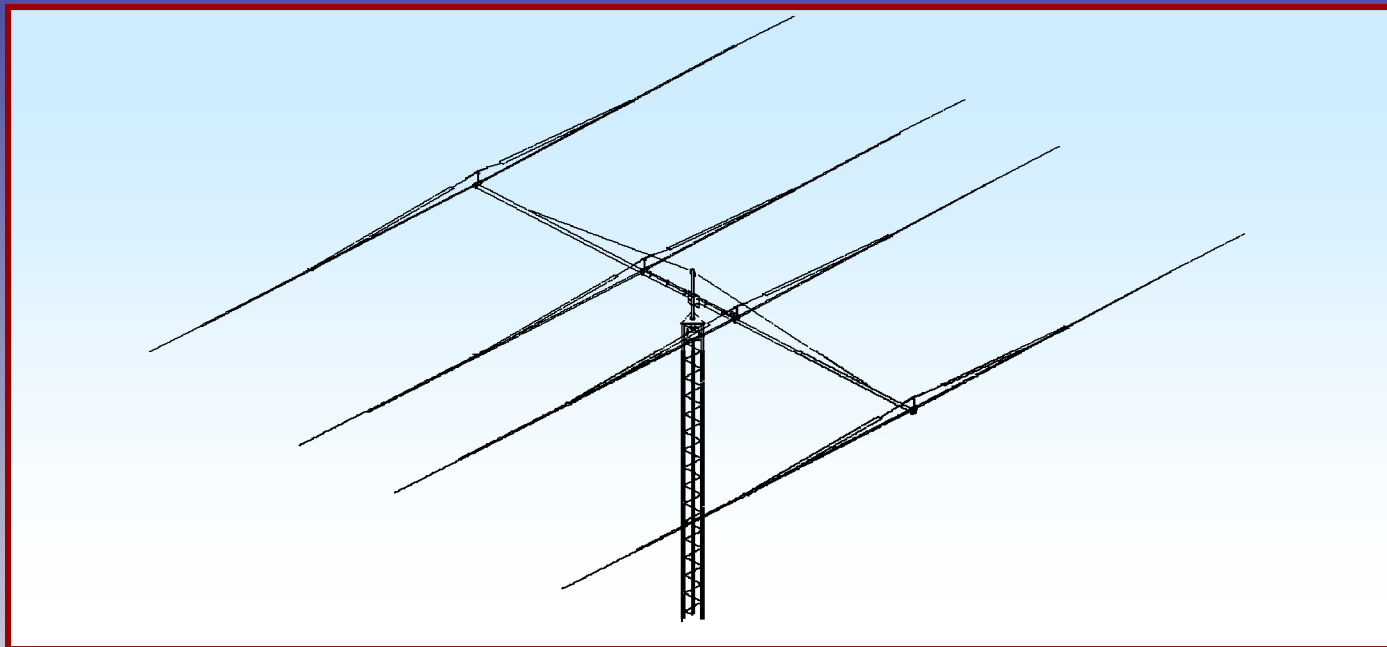

# M2 Antenna Systems, Inc. Model No: 40M4LLDD-125



## SPECIFICATIONS:

Model .....	40M4LLDD-125	Input Connector .....	SO-239, "N" avl.
Frequency Range.....	7.0 To 7.3 MHz	Power Handling .....	3 kW, Higher avl.
*Gain .....	7.5 dBi	Boom Length / Dia.....	42" x 3" x .125
Front to back .....	22 dB Typical	Maximum Element Length.....	51 ft.
Beamwidth .....	60 deg.	Turning Radius: .....	33 ft.
Feed Impedance .....	50 Ohms into 1:1 balun	Wind area / Survival .....	13.3 Sq. Ft. / 125 MPH
Maximum VSWR.....	1.2:1, 2.0:1 max	Weight / Ship Wt.....	185 Lbs. / 190 Lbs.

**\*Subtract 2.14 from dBi for dBd**

## FEATURES:

The recently upgraded, computer optimized, linear loaded, dual driven 40M4LLDD-125 gets the bandwidth and maintains performance across the band like no other 40 meter Yagi. This was a huge challenge requiring the latest techniques in computer optimization. Gain, Front to Back and VSWR are maintained nearly flat across the whole band! In addition, it is now better mechanically and easier to assemble. Only the tips of each element are different as all the linear loading settings are the same for each element. The shorting bars are now 2 piece, clamp type making solid long lasting connections. For foreign amateurs, two tuning options are available; FULL BAND and LOW END ACCENTUATED, but still broadband. The resulting design is head and shoulders above the competition in strength, durability and performance. This antenna has been designed to meet your crossband SSB contesting needs and give you years of enjoyment on the 40 meter band regardless of future band plan changes.

Mechanically, the elements are sleeved double and triple wall to withstand continuous winds of 125 mph or the constant battering of high winds and ice months at a time. This antenna WILL frustrate Mother Nature! The Driven elements are split in the center and insulated with a solid 1-1/4" fiberglass rod. The parasitic element also have solid 1-1/4" center aluminum center section. The 3 kW continuous, 5 kW peak, 1:1 balun completes the package. All hardware is stainless or galvanized except the U-bolts.

**M2 Antenna Systems, Inc. 4402 N. Selland Ave. Fresno, CA 93722**  
**Tel: (559) 432-8873 Fax: (559) 432-3059 Web: www.m2inc.com**

©2014 M2 Antenna Systems Incorporated

10/3/14  
Rev.02

# 40M4LLDD-125 ASSEMBLY MANUAL

**TOOLS NEEDED:** Tools handy for assembly process: Screwdriver, 11/32, 7/16, 1/2, 9/16 and 5/8" spin-tites, end wrenches and/or sockets, measuring tape.

A small container of zinc paste (Penetrox, Noalox, or equiv.) has been provided to enhance and maintain the quality of all electrical junctions on this antenna. Apply a thin coat wherever two pieces of aluminum come in contact or other electrical connections are made.

**NOTE:** Some element inserts or sleeves may be factory installed. Check before assembly!

## **BEFORE YOU BEGIN:**

Look over the ELEMENT ASSEMBLY and DIMENSION SHEET drawings to get familiar with the various parts of the antenna. If you are familiar with the construction of M<sup>2</sup> HF antennas, the 40M4L-125mph can be assembled mainly using the drawings. Otherwise, M<sup>2</sup> strongly recommends using this assembly manual. It will provide you with detailed assistance in critical areas and give overall order and efficiency to the construction process. Take your time: Let your assembly skills enhance the 40M4LLDD-125mph's quality construction and performance.

## **TIP ELEMENT ASSEMBLY – SEE HARDWARE ASSEMBLY DRAWING, DIMENSION SHEET and COMPRESSION CLAMP & TIP ASSEMBLY DETAIL SHEET**

1. Assemble the 3/8", 1/2" and the 3/4-inch diameter element tips first. Connect the sections with compression clamps as shown in drawings.

## **OUTER ELEMENT ASSEMBLY – SEE HARDWARE ASSEMBLY DRAWINGS**

2. Refer to the Linear Loading detail drawing. Slide a ELEMENT OVERHEAD SUPPORT CLAMP onto each of the 1.0 x 60" section just past the fiber glass mounting holes, then add LINEAR LOADING ARM on each section. Position the arm between the two holes. Next, insert the 7/8 x 25.750" sleeve and then the 7/8-inch diameter 9-inch long fiberglass insulator in the end of each of the 1" x 60" assemblies, aligning holes. Install 8-32 x 1/1/4" screws and locknuts to both holes. Then slide the **linear loading arm and element overhead support clamp** up against the 8-32 x 1-1/4" screws head nearest the end. Align it per the ELEMENT ASSEMBLY SHEET and tighten the 8-32 hardware securely.

3. Attach all the STABILIZER INSULATORS to the SUPPORT ARMS using 8-32 x 1" screws and locknuts. Add a LINEAR LOADING ARM and stabilizer insulator assembly to each short 1 x 24" section and position the Linear Loading Arm between the two holes 1/2" and 1-1/2" from end. Now install the fiberglass rod/outer element assembly into the 24" section and secure with two more 8-32 x 1-1/4" screws and locknuts. Slide the linear loading arms back against the inner 1-1/4" screw head. Align it per the LINEAR LOADING HARDWARE DETAIL and tighten the 8-32 hardware securely.

## **4. INNER DRIVEN ELEMENT ASSEMBLY – SEE HARDWARE / ELEMENT ASSEMBLY SHEET**

- A. Select a 1-1/2" OD x 60" ELEMENT SECTION, a 1-3/8" OD x 56" SLEEVE, and a 1-1/4" OD x 48" SLEEVE. NOTE: USE ZINC PASTE OR LIGHT OIL TO EASE ASSEMBLY. Slide the sections together as shown. Place an ELEMENT CLAMP BLOCK on the butt of the 1-1/2" section and secure temporarily with an 8-32 x 2" screw and locknut. Add the CLAMP CAP using a 1/4-20 x 1" flathead bolt and lock nut finger tight at this time.
- B. Next, slide both polyethylene discs onto the 1-1/4" x 24" fiberglass rod. Center the discs on the rod and space them apart by 6". Now slide a 1-1/4" OD x 24" fiberglass rod into the butt end of a 1-1/2" X 60" assembly. Align holes and insert a 1/4-20 x 2" bolt and locknut finger tight. Repeat for remaining driven element sections.

# 40M4LLDD-125 ASSEMBLY MANUAL

**5. REFLECTOR AND DIRECTOR ELEMENTS** are assembled the same as the driven elements except for the following exceptions.

1. 1-1/4" OD X 24" ALUMINUM RODS REPLACE THE **FIBERGLASS RODS**
2. **NO ELEMENT CLAMP BLOCKS ARE USED.**
3. **NO POLYETHELENE DISCS ARE USED.**

## **6. ELEMENT CLAMP ASSEMBLY – SEE ASSEMBLY DRAWINGS**

**A.** Select two (2) #6 ELEMENT CLAMP PLATES and place together over the fiberglass center insulators of one driven element, centering between the two poly disc insulators. NOW slide (4) 1/4-20 x 2-1/2" bolts through the BALUN MOUNTING 'L' PLATE outer holes and attach this assembly to the two clamp plates and add the locknuts, finger tight. Rotate the CENTER ELEMENT SECTION until its mounting bolts are vertical and linear loading arms are horizontal. With rod centered, tighten the 1/4-20 bolts evenly so that plates are parallel and the same amount of threads are showing through all locknuts. Repeat for the second driven element which does not need a balun mounting 'L' bracket.

**B.** Select two more ELEMENT CLAMP PLATES and place them over center of a 1-1/4" center rod sections. Use a thin coat of zinc paste in the grooves in the two plate halves. Loosely install 1/4-20 x 2-1/2" bolts and locknuts in the four outer holes. Rotate the elements until the Linear Loading Arms are horizontal. Center the element so the element is centered between the clamps and tighten the bolts evenly so the same amount of threads are showing through the locknuts. Repeat for the second parasitic element.

**C.** Bolt the welded ELEMENT SUPPORTS (1 x 1 x 24") to the clamp plates with the welded tab over the element centers. Use 1/4-20 x 3-1/2" bolts and locknuts, and tighten. Repeat for all elements.

## **7. LINEAR LOADING ASSEMBLY – SEE ASSEMBLY DRAWINGS**

**A.** Install a pair of LINEAR LOADING RODS to each element half. Insert a rod through each STABILIZER INSULATOR BAR and then through a LINEAR LOADING ARM, allowing about 3/4" to extend beyond the arm. Install 8-32 x 1/4" Allen head screws to lock rods in place.

**B.** Loosely assemble the LINEAR LOADING CLAMP PLATES (SHORTING BAR) pairs using 8-32 x 7/8" screws and locknuts.

**C.** Slide one set of these shorting bars on the ends of the 3/16" linear loading rods. Measure and mark the position for the shorting bars. Move the bars to that location and tighten one screw to hold position. Insert a short section of BLACK PHILISTRAN CABLE (HPTG1200) through one hole, around strain relief and back thru other hole of shorting bar then add 3/16" cable clip to secure it.

**D.** Align the rods and begin to tighten all the 8-32 x 7/8" screws and locknuts. Be sure the rods are parallel and have the same tension. Complete tightening the screws. Repeat for all the element halves.

**E.** Place the element on a level surface with support post "up."

**F.** Prepare eight (16) 1/4" HOOK AND EYE TURNBUCKLES by removing the hook end and running a 1/4-20 plain nut all the way to the hook. Now replace the hook end into the turnbuckle body and thread it in until just one thread shows inside the body of the turnbuckle. Now adjust the other end EYE of the turnbuckle until just one thread show inside the body.

**G.** Install four 1/4" HOOK AND EYE TURNBUCKLES in the welded plates at the middle and at the top of the ELEMENT SUPPORTS. Install a CABLE EYE in the EYE of each turnbuckle and route the BLACK HPTG-1200 Philistran cable through the eye and back on itself. Review the element overhead support clamp detail for proper routing of the BLACK PHILISTRAN CABLE (HPTG1200) to lock the cable to the clamp. Tension the element overhead support line and linear loading assembly and secure the cable with two cable clips on each line as shown. Repeat for remaining elements.

# 40M4LLDD-125 ASSEMBLY MANUAL

- H. Now adjust the turnbuckles, adjusting so the inner sections are level and tighten the turnbuckle jam nuts. Element tips should droop about 4" to 8". The element will be more stable in the wind if you allow some droop to remain in the element.

Inspect each element for tight hardware and balanced tension on linear loading rods. Minor tensioning adjustments can be accomplished using the turnbuckles.

## 8. BOOM ASSEMBLY: REFER TO THE BOOM HARDWARE ARRANGEMENT SKETCH

- A. Examine the center sleeve section and straight 13 ft center boom ends for any nicks, bumps, or chips. File smooth if found. Visually check the inside of the center tube for dirt or debris. Push a paper or cloth towel through to remove any foreign matter. Lubricate the COUPLING RINGS on the CENTER STIFFNER one by one as you insert the sleeve into the boom. Push the sleeve in until it is centered in the section (.aprox 18" in from each end).
- B. Install a 3/8" eyebolt into each of the 180" boom sections. Insert the swaged ends into the center section and align the holes. Add two 1/4-20 x 3-1/2" bolts and locknuts to each joint and tighten securely. Check that both eyebolts are oriented the same.

## 9. ELEMENT TO BOOM ASSEMBLY – SEE DIMENSION SHEET

- A. Loosely install bottom SADDLE CLAMPS to the REFLECTOR and DIRECTOR ELEMENTS using 1/4-20 x 2-3/4" bolts. LUBRICATE THE BOLTS WITH ZINC PASTE. Slide REFLECTOR element onto end of boom, centering the element 3" from the boom end. Tighten up saddle clamp bolts on element while ensuring the eyebolts are oriented up. Move to the DIRECTOR element at other end of boom, align with reflector element and tighten saddle clamp bolts.

- B. Place the REAR DRIVEN ELEMENT on the boom, spacing it 170" (14' 2"), center to center, from the REFLECTOR ELEMENT. Install the saddle clamps and bolts, align to other elements, and tighten clamps.

- C. Place the FRONT DRIVEN ELEMENT on the boom, spacing it 130" (10' 10"), center to center, from the REAR DRIVEN ELEMENT. Install the element so LINEAR LOADING SUPPORT POST IS ORIENTED TOWARDS REAR OF BOOM. Install clamp hardware, align and tighten. Check that DIRECTOR ELEMENT is spaced 202" (16' 10") from front driven element. Adjust if necessary.

## 10. INSTALL PHASING LINES – SEE DIMENSION SHEET

Lay out the 3/16" PHASING LINES and slide on the five (5) Delrin SPACER/STANDOFF RODS. Arrange as shown on Dimension Sheet. USE THE 40M4LLDD PHASING LINE DRAWING AND BEND THE 3/16" X 130" RODS AS SHOWN. Insert THE SHORT BENT ENDS of the phasing lines into grooved channels of clamp block assemblies on REAR DRIVEN element until 1/4" extends beyond clamp, then tighten flat head screw and locknut SLIGHTLY. Now repeat for Front Driven Element, but DO NOT tighten clamp screw nuts until BALUN LEADS are installed in the next Step. Note that phasing lines cross over, feeding element halves on opposite sides of the boom. Secure standoffs to boom with nylon ties.

11. Mount the 1:1 BALUN to the 2" x 4-1/2" BALUN MOUNTING 'L' BRACKET using a 2-1/2" U-bolt. DO NOT OVERTIGHTEN or balun could be damaged. Position THE BALUN INSIDE THE PHASING LINES, at the FRONT DRIVEN ELEMENT with the connector pointing to rear and leads easily reaching phasing line clamp block assembly screw studs. Remove nuts from flathead screws, apply zinc paste to lead lugs, place on screw studs, check phasing lines, and retighten nuts. Position leads to clear all metal objects by at least 1/4". Route your 50 ohm feedline section back to boom to mast plate. Secure to boom with nylon ties.



# 40M4LLDD-125 ASSEMBLY MANUAL

## 12. OVERHEAD GUY SUPPORT SYSTEM : SEE BOOM HARDWARE ARRANGEMENT DRAWING

**A.** Attach one end of the 1/8" steel aircraft cable , using a cable eye and two 3/16" wire clips. Repeat for the other eyebolt

**B.** Attach the BOOM-TO-MAST PLATE to the boom at balance point (boom center) using two 3" U-bolt. Align plate perpendicular to elements.

**C.** TEMPORARILY install a 2" mast section and mount the 2" x 5" TURNBUCKLE PLATE and U-BOLT 3 to 4 feet above the boom. Install the 3/8 –16 jam nuts on the EYE leg of each turnbuckle as before and adjust the ends of the turnbuckles until just one thread shows inside turnbuckle body. Add a cable eye to each turnbuckle eye. Slide two wire clips on the 1/8" cable and route it through the turnbuckle eye. Tension the cables by hand and secure with the wire clips. WHEN INSTALLED ON THE TOWER, GROSS TENSIONING IS DONE BY MOVING THE TURNBUCKLE PLATE UP. FINAL ADJUSTMENTS ARE DONE WITH THE TURNBUCKLES.

**D.** Remove the temporary mast. THE GUY ASSEMBLY is ready to be reattached to the mast during final installation. The TURNBUCKLE PLATE is then raised up the mast until the boom is straight. Then the 2" U-bolt is tightened.

**13.** This completes the assembly of the 40M4LLDD-125mph. *PLEASE BE SAFETY CONSCIOUS DURING INSTALLATION AND ALWAYS USE GOOD QUALITY 50 OHM FEEDLINE AND CONNECTORS.*

Carefully designed and manufactured by:

**M<sup>2</sup> ANTENNA SYSTEMS, INC.**

4402 N. Selland Ave., Fresno, CA 93722

(559) 432-8873 Fax: 432-3059

www.m2inc.com Email: sales@m2inc.com

# 40M4LLDD-125 DIMENSION SHEET

## ELEMENT SPACINGS

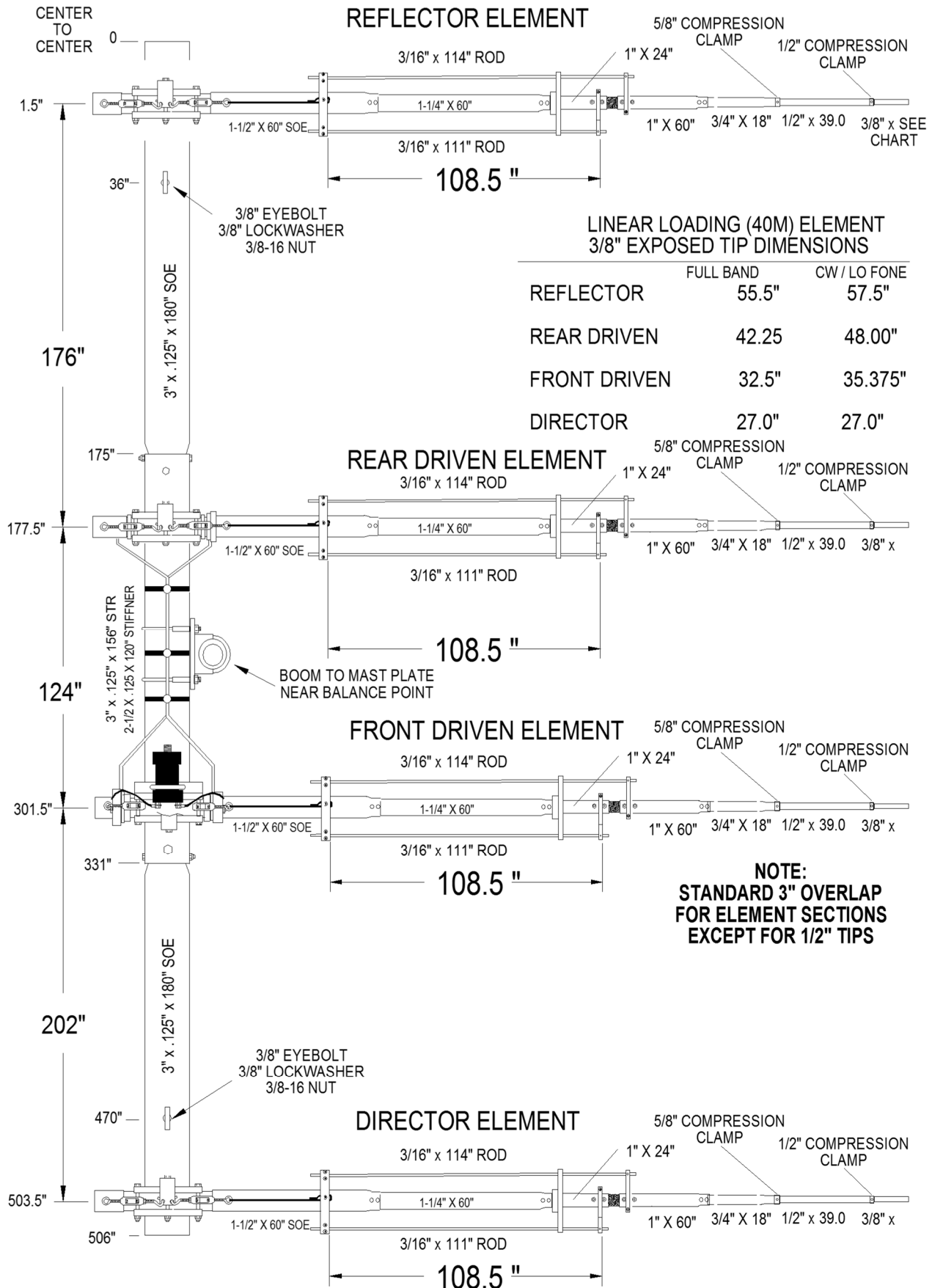

# 40M4LLDD-125 ASSEMBLY MANUAL

## 40M4LLDD PHASING LINE

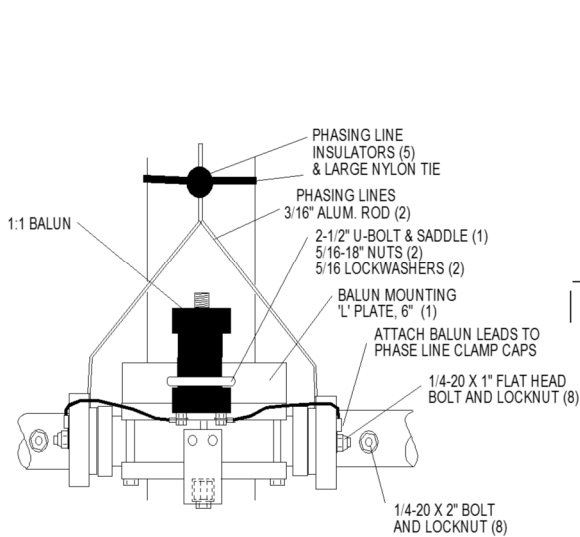

BECAUSE OF THE BEND RADIUS AND THE REQUIRED SMALL HOLES IN THE PHASING LINE SUPPORT INSULATORS, THE USER IS REQUIRED TO BEND THE TWO PHASING LINES AT THE TIME OF ASSEMBLY.

THIS 10" STRAIGHT SECTION ALLOWS CLEARANCE FOR BALUN MOUNTING.

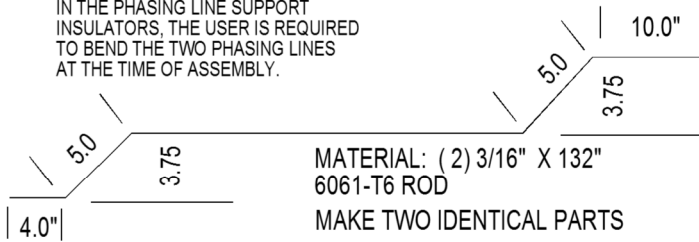

**NOTE:**  
 STANDARD 3" OVERLAP FOR ELEMENT SECTIONS EXCEPT FOR 1/2" TIPS

## ELEMENT ASSEMBLY

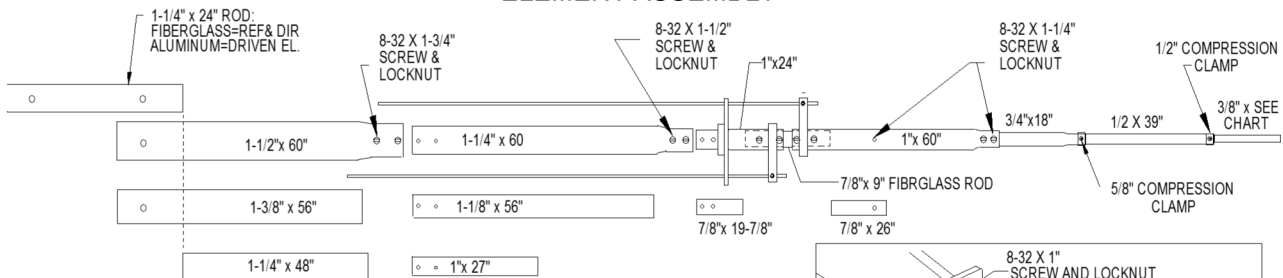

NOTE: SOME INSERT TUBING MAY BE FACTORY INSTALLED.

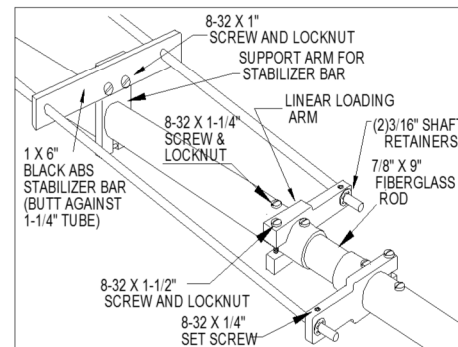

## LINEAR LOADING HARDWARE DETAIL

## TOP VIEW - LINEAR LOADING/ELEMENT CLAMP HDWE

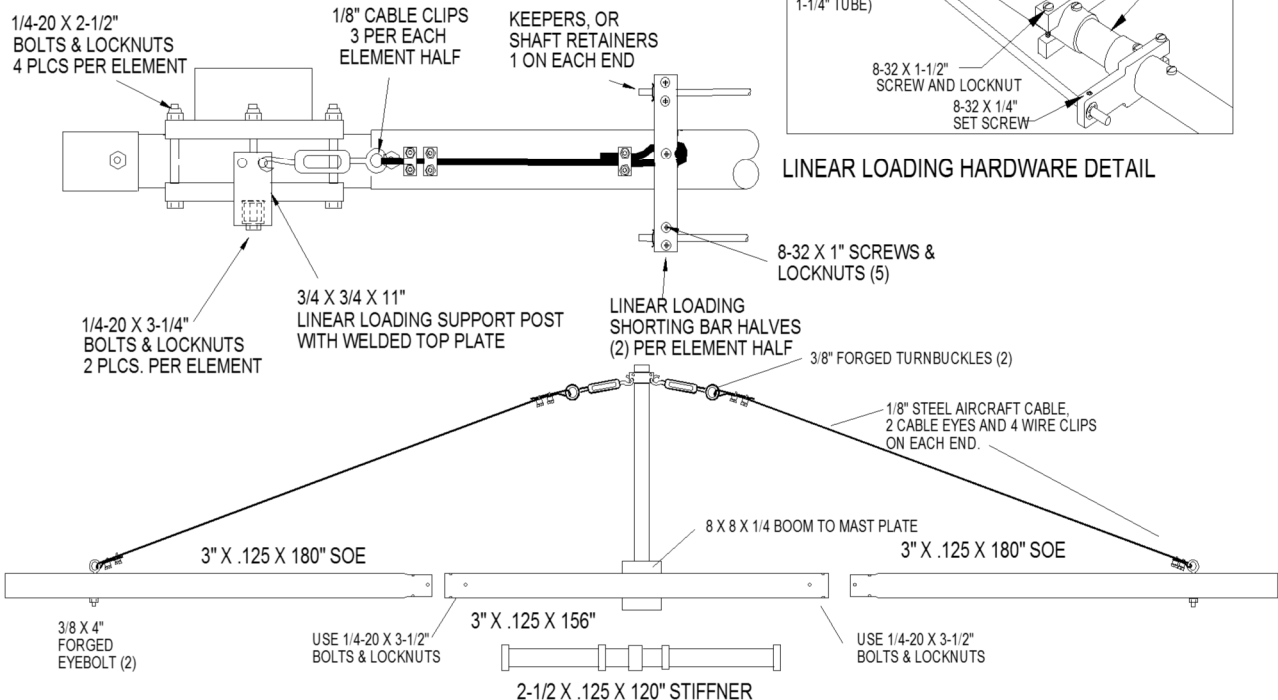

## BOOM HARDWARE ARRANGEMENT

# 40M4LLDD-125 D.E. ASSEMBLY

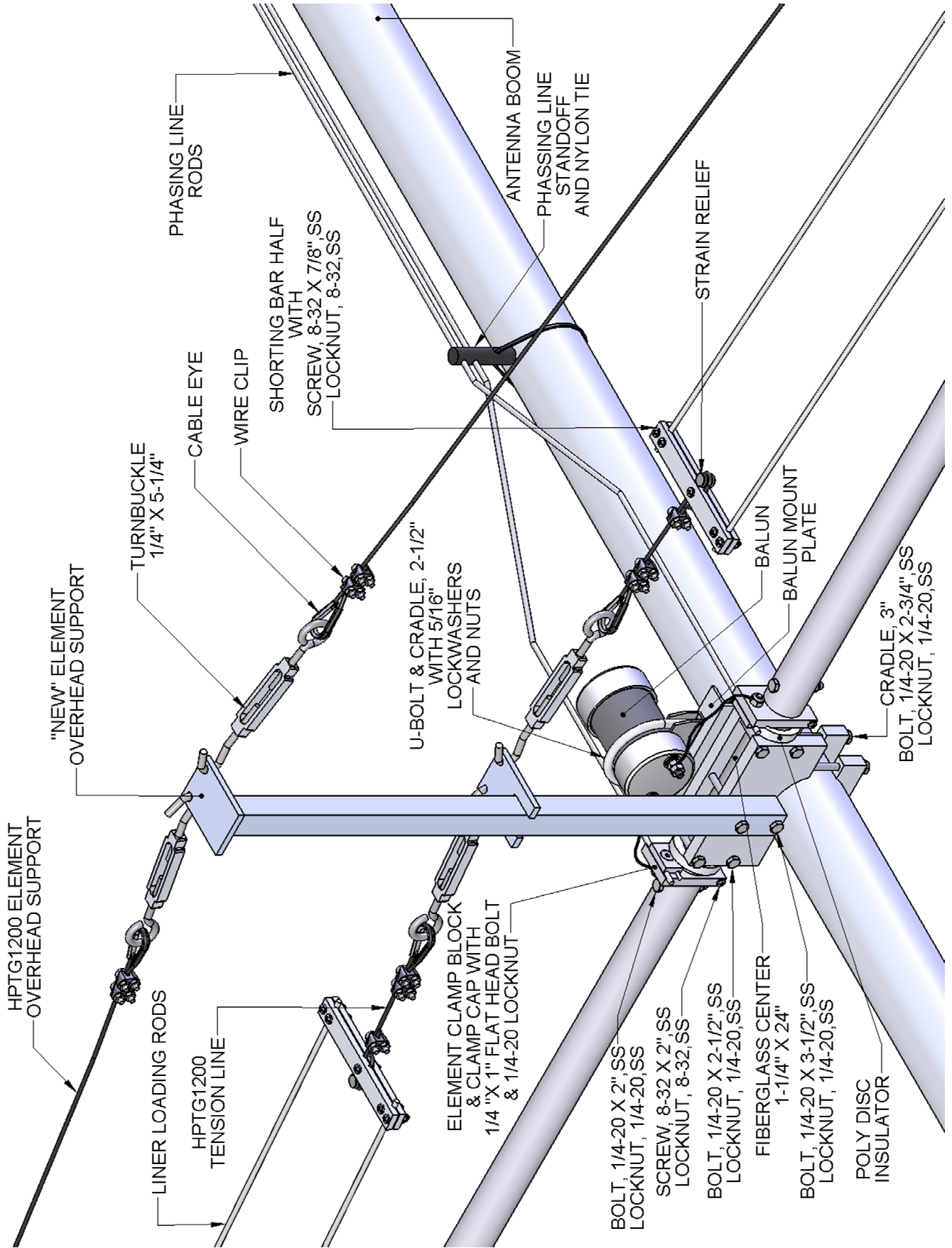

# 40M4LLDD-125 REF/DIR ASSEMBLY

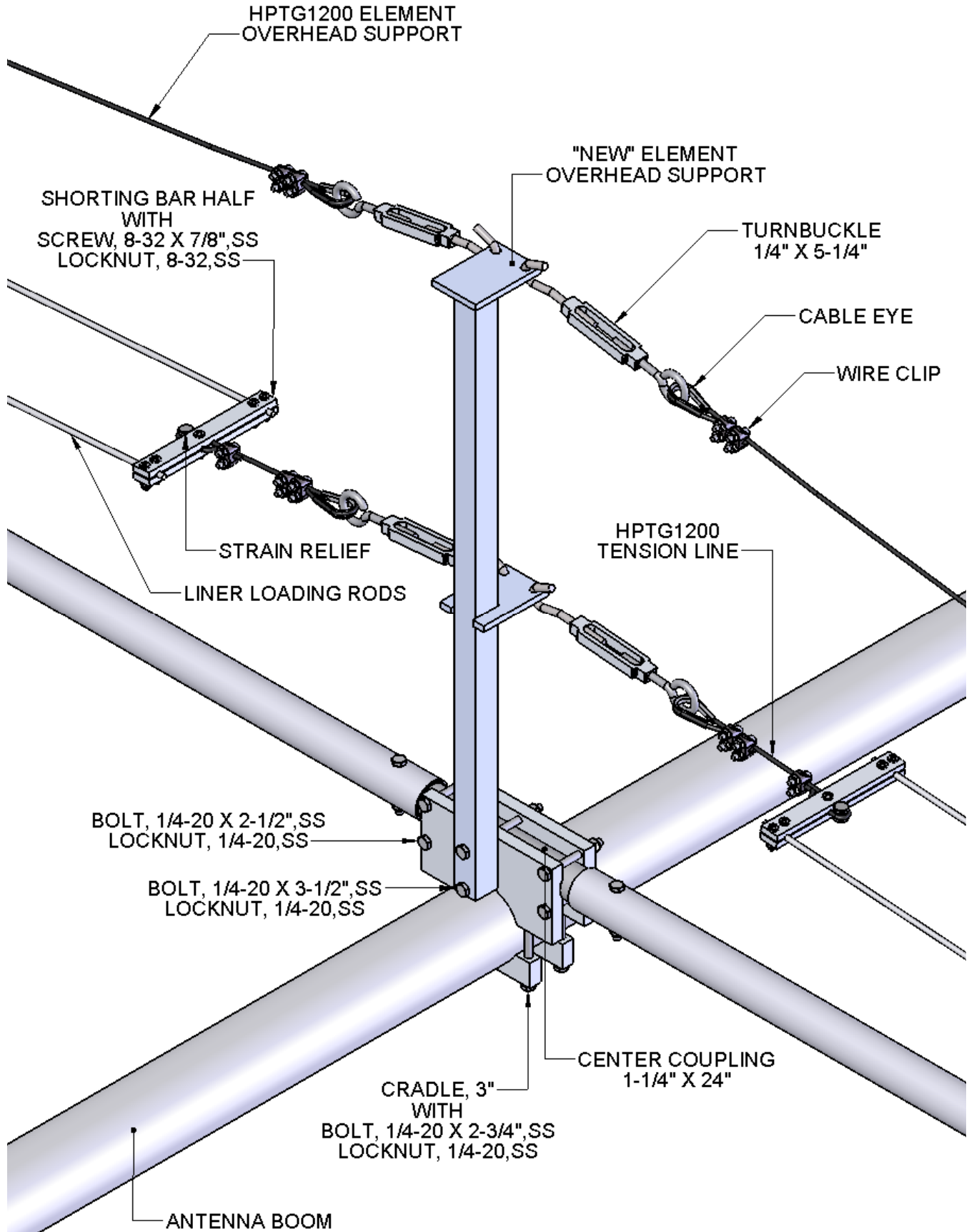



# 40M4LLDD-125 LINEAR LAODING DETAIL

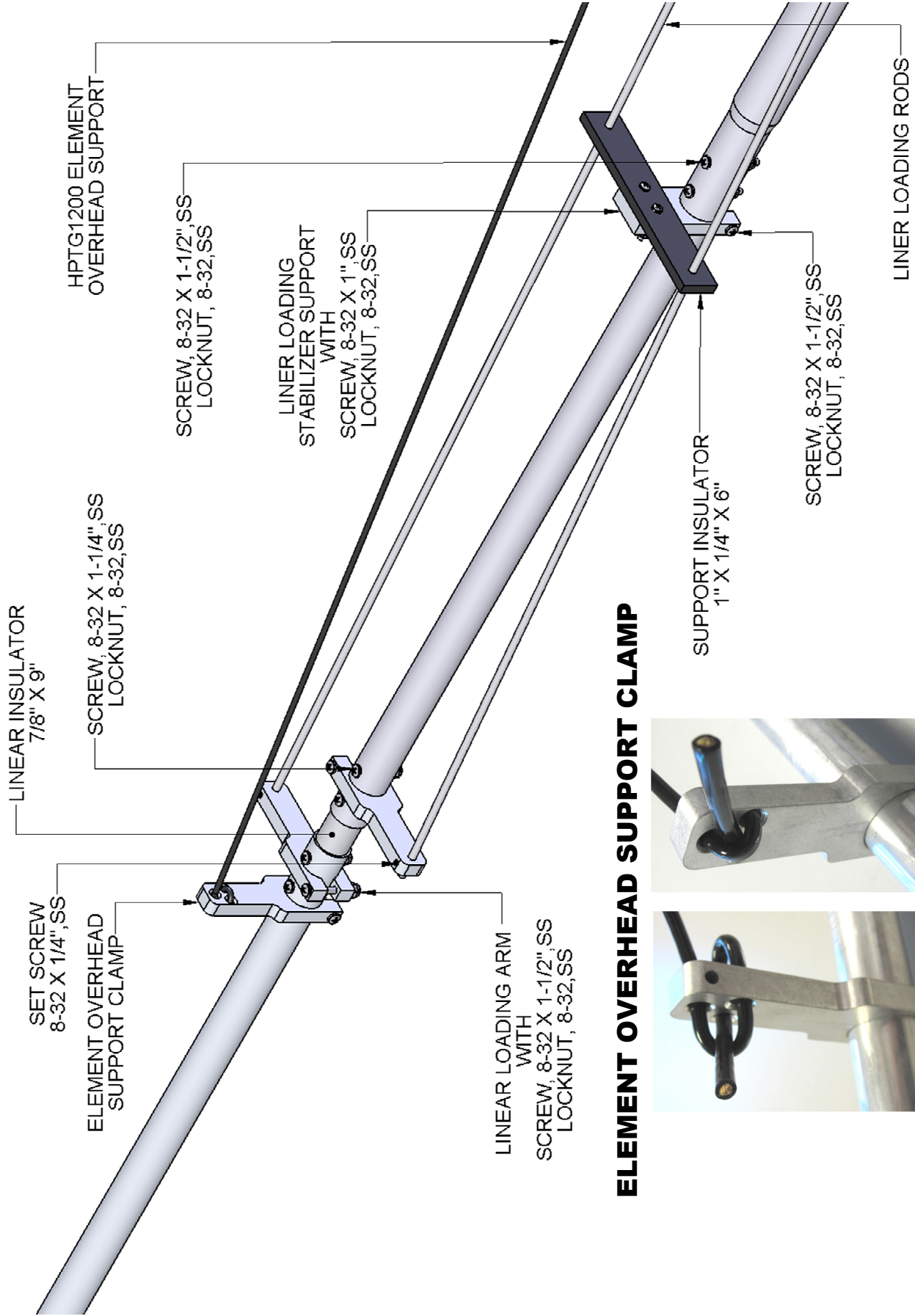

## ELEMENT OVERHEAD SUPPORT CLAMP

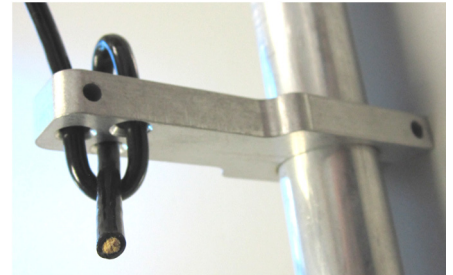

# GENERIC COMPRESSION CLAMP DETAIL

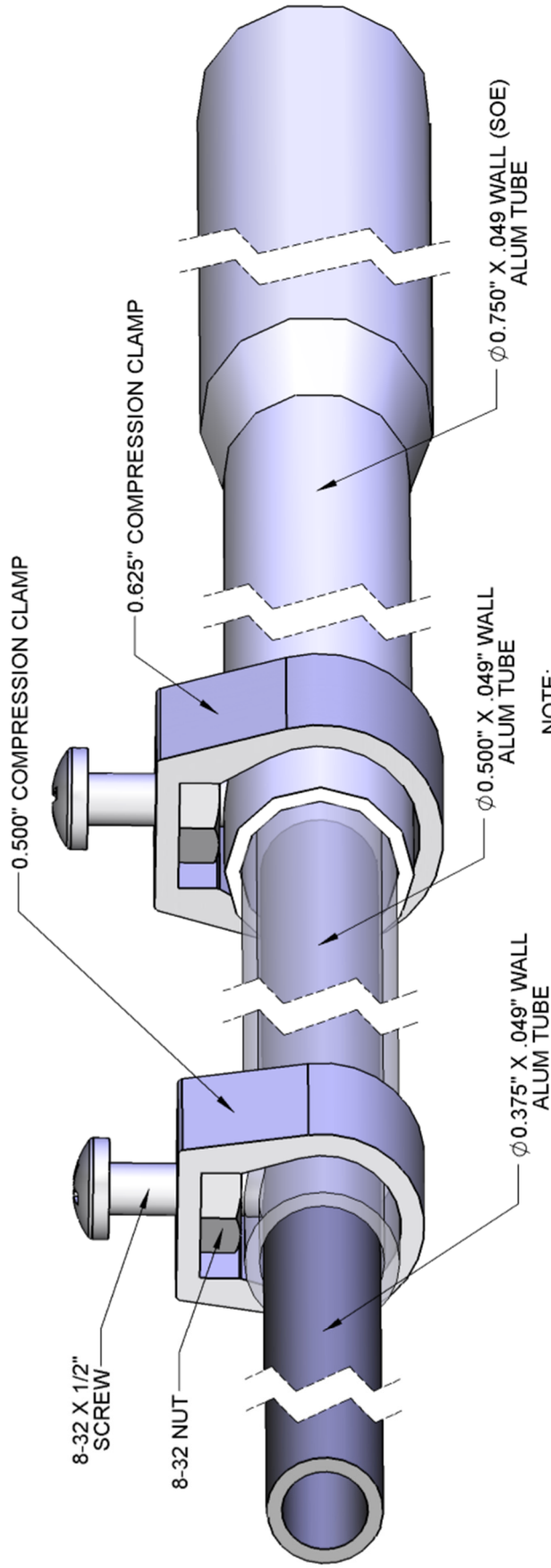

NOTE:  
TUBES SHOWN TRANSPARENT  
TO SHOW MORE DETAIL

**NOTE:**  
Generic layout to show  
how compression clamps work.  
Your antenna may have one or the other  
or may even have both compression  
clamp sizes.

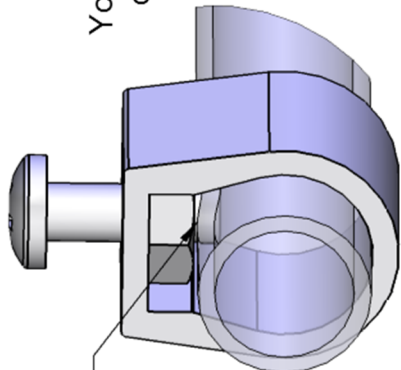

NOTE:  
8-32 X 1/2" SCREW  
PRESSES ON INNER TUBE

NOTE: INSIDE TUBE NOT SHOWN FOR CLARITY

# 40M4LLDD-125 PARTS & HARDWARE

DESCRIPTION	QTY
CENTER COUPLING, 1.25" X 24" ALUMINUM ROD .....	2
INSULATOR, CENTER, 1.25" X 24" FIBERGLASS (M2AFG0034) ....	2
BOOM TO MAST PLATE, 8 X 8 X .250 (M2APT0070) .....	1
BALUN, 1:1, COAXIAL .....	1
STEEL CABLE, 1/8" AIRCRAFT" X 20 FT.....	2
SUPPORT POST, LL, 1" X 1" X 24" SQ TUBE (M2AVR0050).....	4
TENSION LINE, LL, HPTG1200 X 44" .....	8
ELEMENT OVERHEAD SUPPORT, HPTG1200 X 28' .....	4
NYLON TIE, LARGE 11" .....	8
ZINC PASTE, (PENETROX OR NOALOX OR EQUIV.).....	2
ASSEMBLY MANUAL.....	1

## ALUMINUM TUBING

BOOM, 3.0 X .125 X 180" SOE ALUM. ....	2
BOOM, 3.0 X .125 X 156" ALUM. ....	1
BOOM STIFFENER, 2-1/2 X .125 X 120" W / COUPLING RINGS ....	1
SLEEVE, 1.375 X .058 X 56" .....	8
SLEEVE, 1.25 x .058 X 48".....	8
SLEEVE, 1.125 X 56" .....	8
SLEEVE, 1.0 X 27" .....	8
SLEEVE, 0.875 X .058 X19.875" .....	8
SLEEVE, 0.875 X .058 X 25.750" .....	8
ELEMENT, 1.5 X .058 X 60" SOE .....	8
ELEMENT, 1.25 X .058 X 60" SOE .....	8
ELEMENT, 1.0X .058 X 60" SOE .....	8
ELEMENT, 1.0 X .058 X 24".....	8
ELEMENT, 0.75 X .049 X 18" SOE .....	8
ELEMENT, 0.5 X .049 X 39".....	8
ELEMENT TIP, 3/8 X 60".....	2
ELEMENT TIP, 3/8 X 51".....	2
ELEMENT TIP, 3/8 X 38.375" .....	2
ELEMENT TIP, 3/8 X 30".....	2

## ALUMINUM ROD

LINEAR ELEMENT, 3/16 X 114" ALUM. ROD .....	8
LINEAR ELEMENT, 3/16 X 111" ALUM. ROD .....	8
PHASING LINE, 3/16" X 132" ALUM. ROD .....	2

# 40M4LLDD-125 PARTS & HARDWARE

## BAG #1

LINEAR LOADING ARM, 3/8" X1 .25 X 3-3/4" (M2APL0255) .....	16
ELEMENT OVERHEAD SUPPORT CLAMP, 3/8" X 3-3/4" .....	8

## BAG #2

INSULATOR, STABILIZER BAR, NON-METALLIC, 1 X 6" X 1/4" .....	8
SUPPORT ARM, INSULATOR STABILIZER BAR .....	8

## BAG #3

INSULATOR, DISC POLYETHELENE, 1-1/4" ID (M2ADI0020).....	4
ELEMENT CLAMP BLOCK, 1-3/4 X 2-5/8 X 3/8" (M2APL0035).....	4
CLAMP CAP, 1-1/4 X 3/4 X 1/4" (M2APL0067).....	4
INSULATOR, STANDOFF .625 X 2.5" DELRIN (M2ASO0050) .....	5

## BAG #4

SHORTING BAR HALF, LL 1/4" X 3/4" X 5-7/8" (M2ASB0250) .....	16
STRAIN RELIEF, 1/2 X 1/2, BLK DELRIN (M2APL0100).....	8

## BAG #5

SADDLE, CLAMP, 1" X 4" X 1/2" (M2AMC0136) .....	8
---	---

## BAG #6 & #7 TOGETHER

ELEMENT CLAMP PLATE, 3 X 6 X 1/2" #6 (M2AEC0040) .....	8
--	---

## BAG #8

TURNBUCKLE PLATE, 2 X 5" X .188 (M2APT0113).....	1
EYE BOLT, 3/8 X 4", FORGED .....	2
TURNBUCKLES, 3/8, FORGED, JAW AND EYE .....	2
TURNBUCKLES, 1/4 X 5-1/4" HOOK AND EYE .....	16
BALUN MOUNTING 'L' PLATE, 1" X 1" X 6" (M2APT0016).....	1

## BAG #9

INSULATOR, LINEAR, .875 X 9.0" FIBERGLASS (M2AFG0039) .....	8
---	---

## BAG #10

U-BOLT AND SADDLE, 3" (BOOM) .....	2
U-BOLT AND SADDLE, 2-1/2" (BALUN MTG) .....	1

## BAG #11

U-BOLT AND SADDLE, 2" HEAVY DUTY (MAST) .....	4
U-BOLT AND SADDLE, 2" STD (TURNBUCKLE PLATE) .....	1

# 40M4LLDD-125 PARTS & HARDWARE

## BAG #12

NUT, 3/8-16 SS.....	16
LOCKWASHER, 3/8" SPLIT RING, SS.....	16
NUT, 5/16.....	4
LOCKWASHER, 5/16.....	4
BOLT, 1/4-20 X 3-1/2" HEXCAP SS .....	4
BOLT, 1/4-20 X 3-1/4" HEX CAP SS .....	8
BOLT, 1/4-20 X 2-3/4" HEX CAP SS .....	16
BOLT, 1/4-20 X 2-1/2" HEX CAP SS .....	16
BOLT, 1/4-20 X 2" HEX CAP SS .....	8
SCREW, 1/4-20 X 1" FLAT HEAD SS .....	4
NUT, 1/4-20.....	16
NUT, 1/4-20, LOCKING SS.....	40

## HARDWARE BAG #13

SCREW, 8-32 X 2-1/4" PAN SS.....	4
SCREW, 8-32 X 1-3/4" PAN, SS.....	16
SCREW, 8-32 X 1-1/2 PAN SS.....	48
SCREW, 8-32 X 1-1/4 PAN SS.....	56
SCREW, 8-32 x 1 PAN SS.....	24
SCREW, 8-32 X 7/8" PAN, SS.....	40
SCREW, 8-32 X 3/4" PAN, SS.....	8
SCREW, 8-32 X 1/2" PAN, SS.....	16
NUT, 8-32 LOCKING SS.....	196
NUT, 8-32, SS.....	16
WIRE CLIP, 1/8" GALV.....	48
CALBLE EYE (THIMBLE) 3/16".....	20
COMPRESSION CLAMP, 5/8".....	8
COMPRESION CLAMP, 1/2".....	8

## BAG #14

SET SCREW, 8-32 X 1/4 INT HEX SS .....	32
SHAFT RETAINERS, 3/16" SS.....	32
ALLEN WRENCH, 5/64.....	1
PUSH TUBE FOR KEEPER INSTALL. 3/8 X 3".....	1

Carefully designed and manufactured by:

### **M<sup>2</sup> ANTENNA SYSTEMS, INC.**

4402 N. Selland Ave., Fresno, CA 93722

(559) 432-8873 Fax: 432-3059

www.m2inc.com Email: sales@m2inc.com