

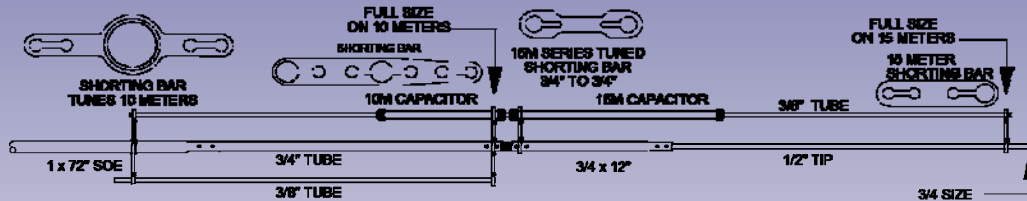

M2 Antenna Systems, Inc.

Model No: KT36XA

It's UPSable!



HIGH EFFICIENCY ELEMENT DESIGN, LARGE CONDUCTORS, HIGH Q CAPACITORS.

SPECIFICATIONS

MODEL NUMBER.....	KT36XA
FREQ. RANGE.....	14.0 - 14.35 MHz 21.0 - 21.45 MHz 28.0 - 29.0 MHz
GAIN (Free Space).....	SEE CHARTS
FRONT TO BACK.....	SEE CHARTS
FEED IMPEDANCE / CONNECTOR.....	50Ω / SO-239
VSWR.....	<1.5:1
POWER HANDLING.....	3 kW
BOOM LENGTH / DIAMETER.....	32' / 3"
ELEMENT LENGTH.....	25'
TURNING RADIUS.....	21.5'
MAST SIZE.....	2" Nominal
WIND AREA.....	9.75 SQ. FT.
WIND SURVIVAL.....	100 MPH
WEIGHT / SHIPPING WEIGHT.....	80 lb. / 85 lb. 2 boxes

10m	f, MHz	G, dBi	G, dbd	F/B
	28.0	9.8	7.7	25
	28.2	10.1	8.0	28
	28.4	10.4	8.3	29
	28.6	10.5	8.4	28
	28.9	10.5	8.4	26

15m	f, MHz	G, dBi	G, dbd	F/B
	21.0	9.2	7.1	19
	21.1	9.3	7.2	22
	21.2	9.4	7.3	24
	21.3	9.5	7.4	24
	21.4	9.6	7.5	23

20m	f, MHz	G, dBi	G,dbd	F/B
	14.0	9.1	7.0	17
	14.1	9.2	7.1	26
	14.2	9.3	7.2	21
	14.3	9.4	7.3	23

FEATURES

The M² KT36XA is the result of many hours spent on perfecting the original KLM KT-34XA through computer optimization confirmed by range and actual on-air tests. Five elements are active on 20 and 15 meters and all six are working on 10 meters! This is the hottest performing tri-bander on the market! A dual driven element (log cell) creates a rig pleasing, flat match, and broad gain & front to back curves across 10, 15, and 20m. A 3 kW 4:1 balun efficiently matches the antenna to 50Ω. All hardware has been upgraded to our machined shorting bars and rugged center element mounts. This is the strongest tri-bander on the market! We probably could have called it the "KB36XA" cause it does! ("KB" = Kicks Butt).

M2 Antenna Systems, Inc. 4402 N. Selland Ave. Fresno, CA 93722
 Tel: (559) 432-8873 Fax: (559) 432-3059 Web: www.m2inc.com

©2018 M2 Antenna Systems Incorporated

2/13/2018
REV A

KT36XA ASSEMBLY MANUAL

Tools: Phillips head screw driver, 'green', 11/32" nutdriver, 7/16" wrench, 7/16" socket, socket wrench, tape measure, and a friend.

NOTE: To prevent galling of the stainless steel hardware, apply a light coating of Penetrox to all bolts and screws. The term 'SWAGE' refers to a physical reduction made in one diameter of tubing in order to fit into or over another.

1. SHORTING BARS

Included with this kit are five different shorting bars, pictured in Figure 1. First locate the 10m shorting bars and shorting bar insulators (black or white). For each 10m shorting bar press a single shorting bar insulator into the large hole. This can be done initially with a vise or with a hammer and a block of wood. After the insulator has been partially set into the hole, take two element clamp plates and center the shorting bar on top of the two plates. Now place the block of wood on top of the insulator and give a final strike. You should hear a snap.

This is the indication that the insulator has been secured. Locate the small container of Penetrox and for each shorting bar, apply a light coating to the walls as indicated in the figure. Next install the 8-32 hardware listed to the right of each part into each respective shorting bar. Remember to apply a light coating of Penetrox to the threads of each screw. Finger tighten each locknut for now.

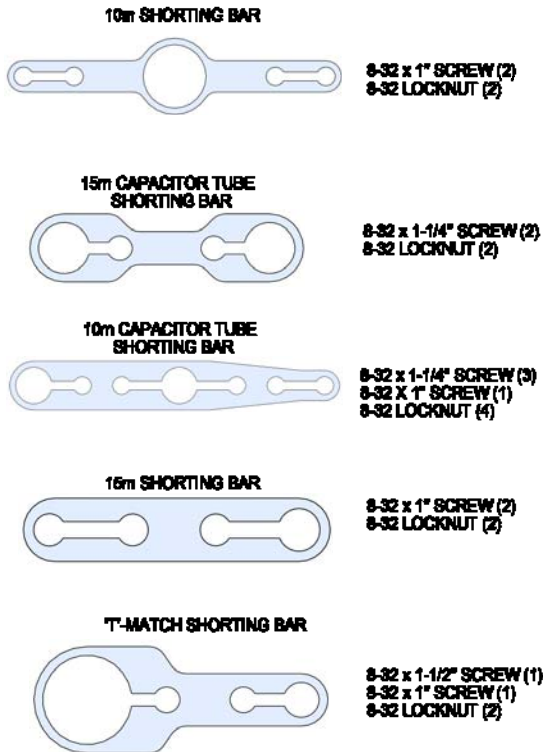
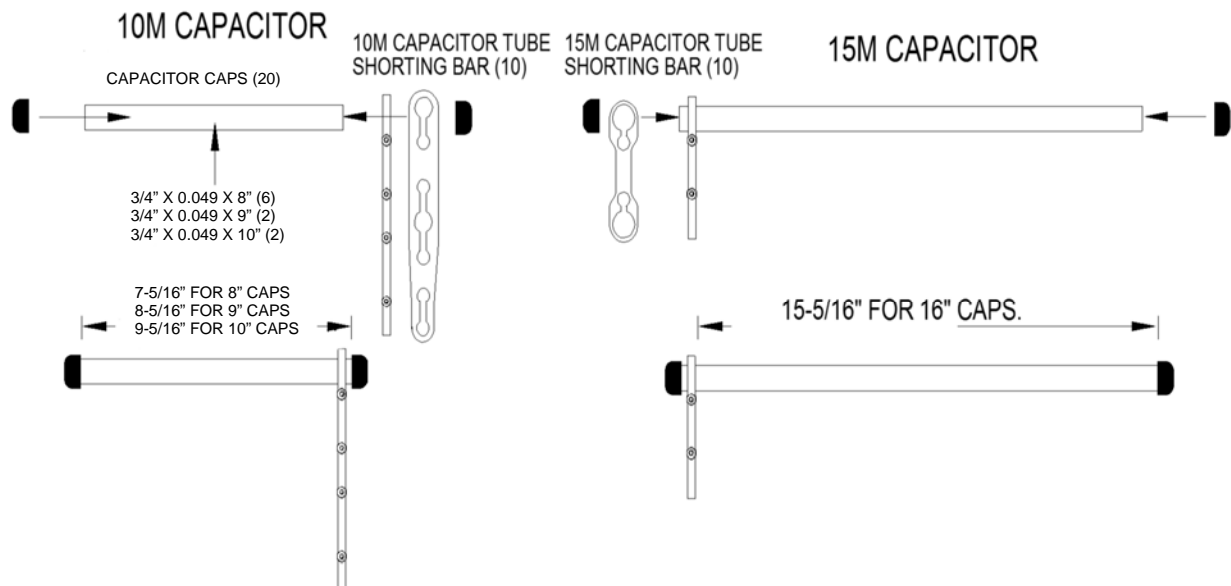

Figure 1

2. CAPACITOR TUBE ASSEMBLY

There are four sizes of capacitor tubes. Tube sizes 8", 9" and 10" are for the 10m capacitor while the 16" pieces are for 15m. Locate the shorter 3/4" diameter tubes and arrange them according to length. Also locate the bag of capacitor caps. As shown in Figure 2, starting with the 8" tube, lay a capacitor cap on a flat surface and with your own strength press one of the tube ends into the cap. Now slide on the shorting bar all the way to the cap, turn the tube over, and install another cap. Each capacitor cap will engage the 3/4" tube 3/8"(.375) so a measurement can be taken to insure complete engagement of the caps to the tube, simply measure between the inside edge of the two installed caps, it should be 5/8"(.625 to 3/4"(.750) shorter than the capacitor tube being measured. Repeat this procedure for the 10" capacitor tube. For the 16" tubes follow the same procedure but slide on a different shorting bar as shown in the figure.



KT36XA ASSEMBLY MANUAL

3. CAPACITOR ASSEMBLIES ONTO LONGER 3/8" TUBES

Locate the ten longer 3/8" diameter tubes. Upon inspecting the tubes, you'll notice there are two holes drilled on one side only. The holes are to prevent moisture build up inside the capacitor tubes and to provide pressure equalization. Denote the hole side of the tube by making an identifying mark on the tube ends, with a pen or marker. Following the information in Table 1, make another mark on the hole side of the tube indicating the location of where to initially center the two capacitor tubes. As shown in Figure 3 below, make this measurement from the side that has the shorter distance from hole to tube end. Now pair up the capacitor assemblies with the correct 3/8" tube sizes using the first three columns of Table 1.

Table 1. Capacitor Tube Assembly & Starting Setup Dimensions (Not Critical)

ELEMENT	10m CAPACITOR TUBE	15m CAPACITOR TUBE	3/8" DIA. TUBE	CENTER CAPACITOR TUBES ON 3/8" DIA TUBE
REFLECTOR	10"	16"	80"	29-3/16"
REAR DRIVEN	9"	16"	80"	30-3/4"
FRONT DRIVEN	8"	16"	72"	26-15/16"
1ST DIRECTOR	8"	16"	74"	29-3/16"
3RD DIRECTOR	8"	16"	74"	28-3/4"

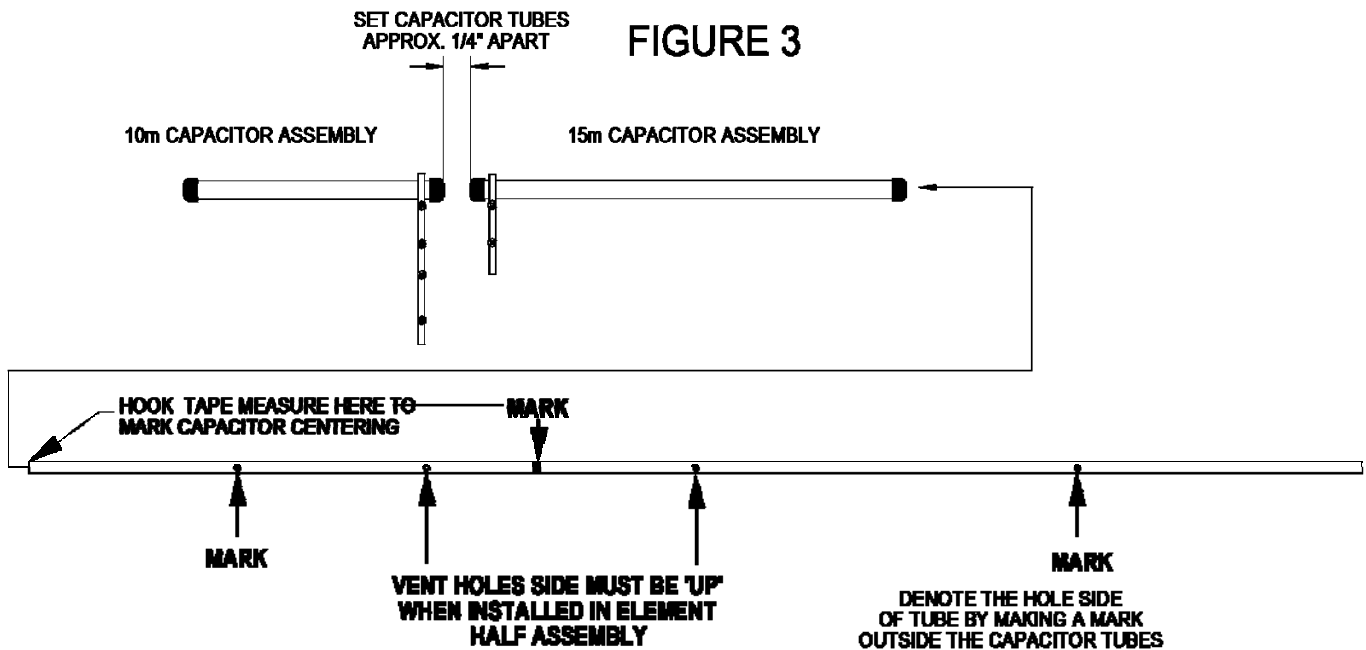

For each set of capacitor tube assemblies and 3/8" tubes, insert the 3/8" tube as shown in Figure 3 into the back end of the 15m capacitor assembly. Move the capacitor up the length of the tube until the face of the black capacitor cap ON THE SHORTING BAR SIDE of the capacitor assembly is 1/8" to 1/4" from the mark you made. Now slide on the 10m capacitor tube assembly up the length of the tube in the same fashion, making sure that the face of the capacitor cap is also 1/8" to 1/4" from the mark. There should now be a 1/4" to 1/2" separation distance between the two capacitor assemblies. This is not a critical dimension it provide a gap between the two caps to prevent water wicking.

KT36XA ASSEMBLY MANUAL

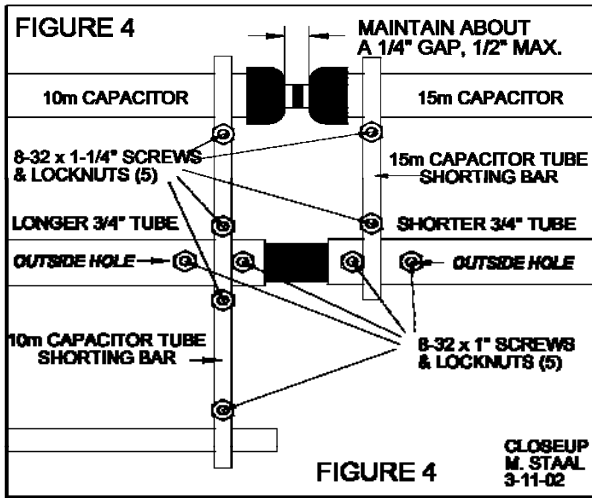

4. GENERAL ASSEMBLY OF HALF ELEMENT SECTIONS
 We recommend assembling the half element sections on a clean, flat surface. There is an assembly drawing for each of the six elements with both the right and left halves shown on each page. We also recommend briefing yourself with the general directions before skipping to the assembly drawings.

The general assembly procedure for a half element section begins with laying each capacitor assembly on a level surface, with the 10m capacitor tube on the left hand side. Locate the two swaged 3/4" dia. tubes and the 5/8 x 6" fiberglass rod. **NOTE: BE SURE TO USE THE CORRECT LENGTH 3/4" SECTIONS MATCHING UP WITH THE 10M CAPACITOR LENGTH.** Insert the fiberglass rod into the LIGHTLY swaged end side of the longer 3/4" section. Align the two holes and secure loosely with a single 8-32 x 1" screw and lock nut in the outer hole as shown in Figure 4. Next slide the other end of the fiberglass rod into the center hole of

the 10M shorting bar connected to the 10m capacitor. Slide the larger diameter swage of the shorter 3/4" X 12" tubing through the hole of the shorting bar connected to the 15m capacitor tube. Secure with a single 8-32 x 1" screw and locknut, again through the OUTER HOLE in the figure. Now insert the inner two 8-32 x 1" screws and locknuts, and tighten LIGHTLY. NOTE: IF YOU OVER TIGHTEN, YOU MAY NOT BE ABLE TO MOVE THE SHORTING BARS TO FINAL POSITION. Slide the two shorting bars right up against the two inner locknuts as shown. Now tighten all four inner and outer screws and locknuts. Position the capacitor tube assembly so that the gap rests in between the two shorting bars and MAKE SURE THE MARKS YOU MADE ON THE 3/8" TUBE ARE UP. Tighten all of the 8-32 hardware installed to this point.

Locate the appropriate 1/2" element tip section and insert the end with 2 holes into the 3/4 x 12" swaged end. Secure the 1/2" tip with two 8-32 x 1" screws and locknuts. With a tape measure hooked to the inner edge of the 15m capacitor tube shorting bar, make a mark on the 3/8" tube at the dimension called out for the 15m shorting bar. Slide the 15m shorting bar onto the 3/8 and 1/2" tube and set the inner edge of the bar to the mark. Install two 8-32 x 1" screws, add locknuts, align with the other bars and tighten.

Locate the 10m shorting bar and the shorter 3/8" tube. Using a tape measure connected to the inner edge of the 10m capacitor tube shorting bar, mark the dimension called out for the 10m shorting bar. Slide on the 10m shorting bar, set the inner edge to the mark and tighten the top 8-32 screw. Now insert the shorter 3/8" tube through the other hole on the 10m shorting bar and into the free hole on the 10m capacitor tube shorting bar. Allow the tube to extend 1" past the shorting bar connected to the 10m capacitor and tighten the 8-32 hardware on both of the shorting bars.

KT SERIES HALF ELEMENT DETAIL

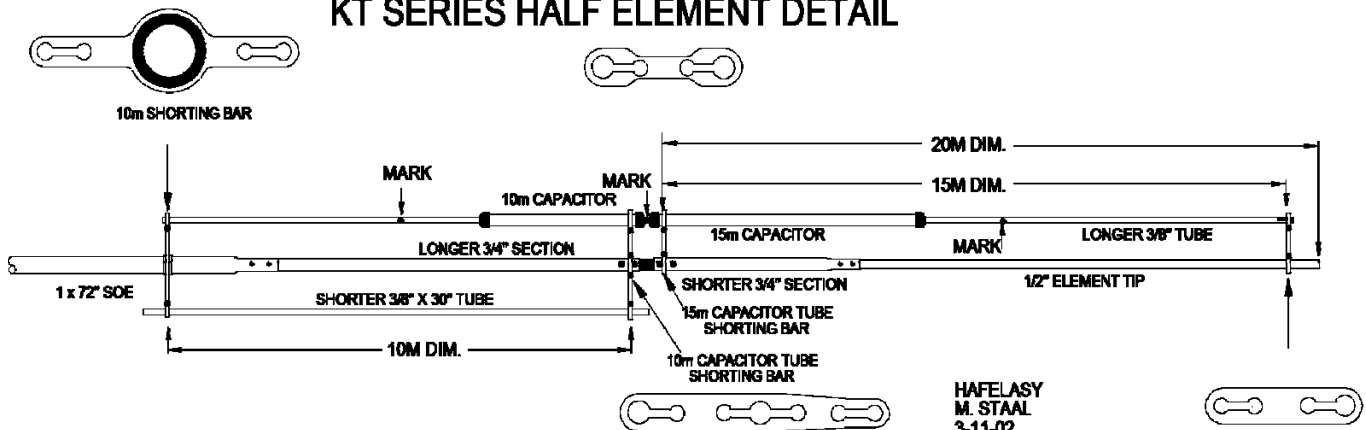

FIGURE 5

Using the general directions above and the six TIP DIMENSION / ASSEMBLY drawings, proceed in fabricating the 12 half element sections. After double checking your dimensions and making sure that your elements are labeled correctly proceed to the next step.

KT36XA ASSEMBLY MANUAL

5. HF CLAMP PLATE PAIR ASSEMBLY

Locate the 11 element clamp plates, the Balun 'L'-Bracket, 2-1/2" U-bolt & Saddle, and element clamp cap. Assemble the plates into six pairs with the radii facing each other using four 1/4-20 x 2" bolts. On one of the 'alike'-pair combinations, attach the Balun 'L'-Bracket to the outside clamp plate with the flat side up and higher than the plates. Install the 2-1/2" U-bolt & Saddle combination on the top side of the 'L'-Bracket and secure with 5/16" nuts and lock washers. This assembly will be used for the FRONT DRIVEN ELEMENT. Finger tighten all the hardware. The 'oddball' plate combination of element clamp plate and smaller clamp cap, will be used for DIRECTOR #2.

6. FRONT AND REAR DRIVEN ELEMENT ASSEMBLY

Take the element clamp plate pair assembly for the FRONT DRIVEN ELEMENT (previous step) and one of the 'alike' element clamp pairs, and for both insert a 7/8 x 14-3/4" fiberglass rod through the plates. Orient the four holes up and make sure the rod is centered. Tighten the four bolts evenly on the clamp plates. Locate the four 7/8" poly disc insulators. Slide a poly disc onto both ends of each 7/8" fiberglass rod and position them right up against the element clamp plates. If the discs won't fit onto the rod, try soaking them in HOT water for a few minutes. Locate four of the 1 x 72" SOE (swaged one end) tubes. Select two to be used for the FRONT DRIVEN ELEMENT. Locate the two 'T'-match shorting bars and slide one onto each of the straight ends of the 1" tubes you have selected. The other pair of 1 x 72" SOE tubes will be for the REAR DRIVEN ELEMENT. For all four 1" tubes, slide the straight ends on both sides of the two fiberglass rods. Align the holes, insert two 1/4-20 x 2" bolts up through the bottom, and temporarily lay the two assemblies flat. Locate the eight 3/8" clamp blocks. Spread a little Penetrox on each clamp block face. Slide two clamp blocks with their faces towards one another onto the 1/4-20 bolt posts on each element assembly and thread on the 1/4-20 locknuts. Do not tighten the locknuts at this time. Paying close attention to the DIMENSION SHEET, insert the individual element halves for the FRONT and REAR DRIVEN ELEMENTS into the swaged ends of the 1 x 72" tubes. Secure them with 8-32 x 1-1/4" screws and locknuts. Make sure the flat part of the 'L'-Bracket is pointed in the same direction as the capacitor tube sides of the FRONT DRIVEN ELEMENT halves.

7. REFLECTOR, DIRECTOR #1, AND DIRECTOR #3 ASSEMBLY

Locate the remaining six 1 x 72" SOE (swaged one end) tube sections and the three 7/8 x 36" aluminum center sleeves. With the three remaining pairs of 'alike' element clamp plates, insert a 7/8" center sleeve and slide a 1

x 72" tube section onto both sides of the sleeve. Align the two holes and secure with 1/4-20 x 1-1/2" bolts and locknuts. Orient the tubes so that the locknuts are down and centered. Tighten the 1/4-20 hardware evenly. A 1" gap between the two tube sections is normal.

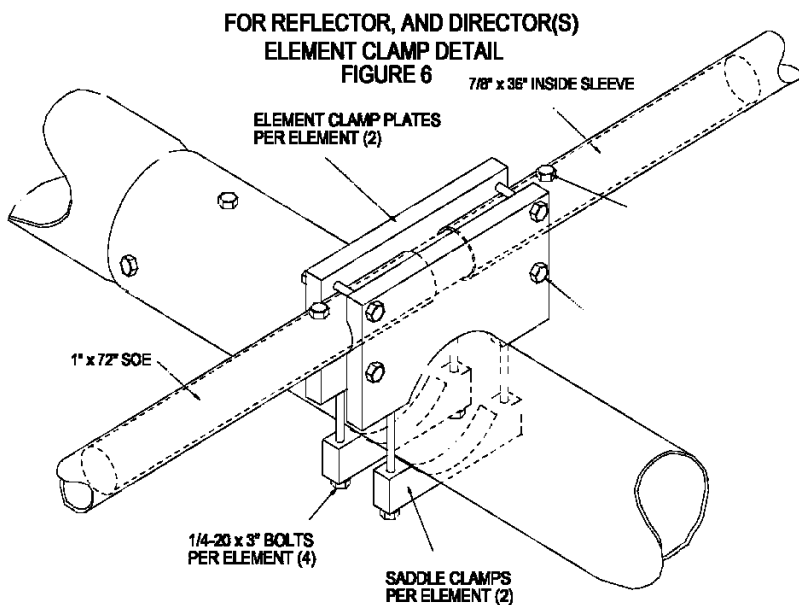

8. DIRECTOR #2 ASSEMBLY

Locate the 1 x 20" SBE (swaged both ends) center support tube and insert this piece between the plates of the remaining 'oddball' element clamp assembly. Orient the tube holes up, center the tube, and tighten the 1/4-20 hardware. Now insert the two 3/4 x 48" SOE tubes into both ends of the center support tube and secure with 8-32 x 1-1/4" screws and locknuts. Add the 1/2" element tip sections to the 3/4" tubes, securing them with 8-32 x 1" screws and locknuts.

9. BOOM ASSEMBLY

Prior to assembling the boom, inspect each mating surface and holes for any metal chips or burrs. Apply a light coating of PENETROX to the swaged ends of each piece. Using the DIMENSION SHEET as a guide, lay out the five 3" pieces as shown. Note that the single straight section is the FRONT end of the antenna. Now assemble the boom and secure the pieces together with 1/4-20 x 3-1/2" bolts and locknuts. Next insert the two 3/8 x 6" eyebolts through the holes at both ends of the boom. Secure them with 3/8" nuts and lock washers.

KT36XA ASSEMBLY MANUAL

10. ELEMENT INSTALLATION

We advise that you elevate the antenna boom onto a couple of sawhorses or bucks for the remaining assembly steps. Use the DIMENSION SHEET as a guide to properly install the six elements onto the boom. If you have not labeled which side of the element faces towards the front of the antenna, you will want to pay close attention to the DIMENSION SHEET. In fact, you might want to label them now. You also might want to have a friend handy to keep the antenna from moving on you.

Place the REFLECTOR ELEMENT onto the boom in the orientation shown on the DIMENSION SHEET. Set the outside edge of the element clamp plate **2-1/2"** from the rear of the boom. Locate two 3" saddles and insert two 1/4-20 x 3" bolts through each of the holes. Next attach the two saddles to the underside of the element clamp plates, and lightly tighten the entire assembly, so the element won't move. Using a tape measure hooked to the outside edge of the clamp plate facing the rear, mark off the location for the outside edge of the element clamp on the REAR DRIVEN ELEMENT assembly with a marking pen or pencil. Install the REAR DRIVEN ELEMENT as you did for the REFLECTOR. **BE CAREFUL!** This element is not installed in the same orientation. Make sure you follow the element placement on the DIMENSION SHEET. Continue installing the rest of the elements in the same fashion. Since the 2nd director only has one element clamp plate, it requires just a single 3" saddle. Also take note that this element can be placed on the boom with the clamp cap facing either the FRONT or REAR of the antenna.

After all of the elements have been installed take a couple of steps back and look down from the end of the antenna. Check to see if the elements are lined up with one another. If any need to be fixed, simply loosen the saddles, straighten, and re-tighten.

11. INSTALLATION OF PHASING LINES

Locate the two 3/8" tube phasing lines, the phasing line insulator, and one cable tie. Insert both tubes into the two holes on the insulator. Temporarily loosen the 1/4-20 locknuts located on the FRONT and REAR DRIVEN ELEMENTS and slide the two phasing lines into the one of the 3/8" clamp block sets. Allow the ends of the phasing lines to stick out 4" past the ends of the clamp blocks. Now pull the phasing lines back, guiding them into the clamp block set on the other driven element. Now re-tighten the four 1/4-20 locknuts. Set the insulator about midway between the two elements and secure it with large nylon tie inserted through the bottom hole and around the boom.

12. BALUN INSTALLATION

Refer to the figures on DUAL DRIVEN AND T-MATCH ASSEMBLY for this procedure.

Loosen the 2-1/2" U-bolt on the L-bracket and insert the 4:1 HF Balun with the connector facing towards the front of the antenna. Position the Balun so that the U-bolt hits the edge of the front cap. Now tighten the U-bolt just enough to hold firmly in place. **BE CAREFUL!** Overtightening might crack the case of the Balun. On each of the mounting posts on the balun attach the balun straps (shorter side).

13. 'T'-MATCH INSTALLATION

Refer to the figures on DUAL DRIVEN AND T-MATCH ASSEMBLY for this procedure.

Locate the two 1/2 x 23-1/2" 'T'-Feed tubes and 3/8 x 10" fiberglass insulator. Install the 3/8" fiberglass insulator into one of the 1/2" 'T'-feed tubes. Align the holes and temporarily secure with a 8-32 x 1" screw. Now feed the undrilled ends of both 'T'-feed tubes into the two 'T'-match shorting bars. Slide one of them back so you can install the other end of the 3/8" fiberglass rod into the other 1/2" tube. Align the holes and secure with another 8-32 x 1" screw. With all of the hardware loose, rotate the entire 'T'-Match assembly up so that the two 8-32 screws fit right into the two Balun straps. Secure the two 8-32 screws with two 8-32 locknuts. Make sure there is ample room to connect your feedline to the balun. Now set the two shorting bars to the dimensions shown on the DIMENSION SHEET and tighten all the hardware.

14. BOOM TO MAST PLATE INSTALLATION

Locate the boom to mast plate, 3" U-bolts & saddles, and 2" U-bolts & saddles. Install the four 2" U-bolts on one side of the boom to mast plate. Center the plate at the location shown on the DIMENSION SHEET, and install it using the 3" U-bolts, saddles, 3/8" nuts, and lock washers. If possible, attach the feedline to the balun and route it forward to about 18 feet from the rear of the boom. Seal the connector with black tape, coax seal or equivalent. A 3" U-bolt pattern exists should you need to mount the antenna to a 3" mast.

KT36XA ASSEMBLY MANUAL

15. OVERHEAD GUY SUPPORT

To prepare the overhead guy system, begin by **temporarily** installing a 2" U-bolt through the TURNBUCKLE PLATE and into the top set of 2" U-bolt holes on the boom to mast plate. Add a couple of 5/16" nuts to hold it in place. UNSCREW the turnbuckle eyes / hooks until only a thread or two shows inside the turnbuckle body and hook them to turnbuckle plate.

Uncoil the DACRON ROPE. Secure one end to rear eyebolt, taking two turns through the eyebolt, then adding three TIGHT half-hitches. Pull hard on cord to set the knots. Repeat for the front eyebolt. Seal cord ends with heat (lighter, propane torch, etc.) and tape to main length.

Equalize cord length at turnbuckle plate and cut. Put two turns trough rear turnbuckle eye. Pull the Dacron rope as tight as possible and add three TIGHT half-hitches. Repeat for the front cord section. Seal and tape cord ends. When finished, the overhead guys should be taught and laying parallel with the boom. Now remove the turnbuckle plate from the boom to mast plate and lift it temporarily to note the approximate height at which the boom becomes level. (usually about 3 feet).

During final installation on the tower / mast, secure the turnbuckle plate at the appropriate height with the 2" U-bolt. Then lean or pull on the cords to increase the tension and help the knots take their final "set." Make sure the knots are not slipping. When the guy system has taken a "set", loosen the 2" U-bolt and adjust turnbuckle plate height until boom is straight and level. Finer adjustments can be made with the turnbuckles at any time, if necessary.

This completes the ASSEMBLY. REMEMBER to support the feedline at the antenna boom and on the mast. Leave an adequate feedline loop for rotation around the tower. When stacking this antenna with other H.F. models, maintain at least 8' separation; more if practical. Mount horizontally polarized VHF and UHF antennas at least 40" above or below this antenna to minimize interaction.

Carefully manufactured by:

M² ANTENNA SYSTEMS, INC.

4402 N. Selland Ave.

Fresno, CA 93722

(559) 432-8873 Fax: 432-3059

www.m2inc.com Email: sales@m2inc.com

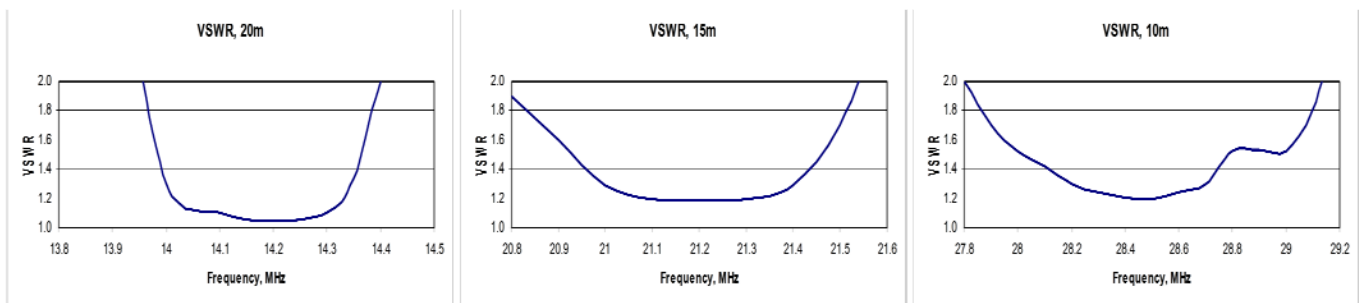

KT36XA-HALF ELEMENT-GENERAL ASSEMBLY

ASSEMBLE ELEMENT HALVES ON A CLEAN, FLAT SURFACE

APPLY A LIGHT COATING OF PENETROX TO ALL METALLIC MATING SURFACES INCLUDING SCREWS



10m SHORTING BAR

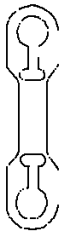

15m CAPACITOR TUBE SHORTING BAR

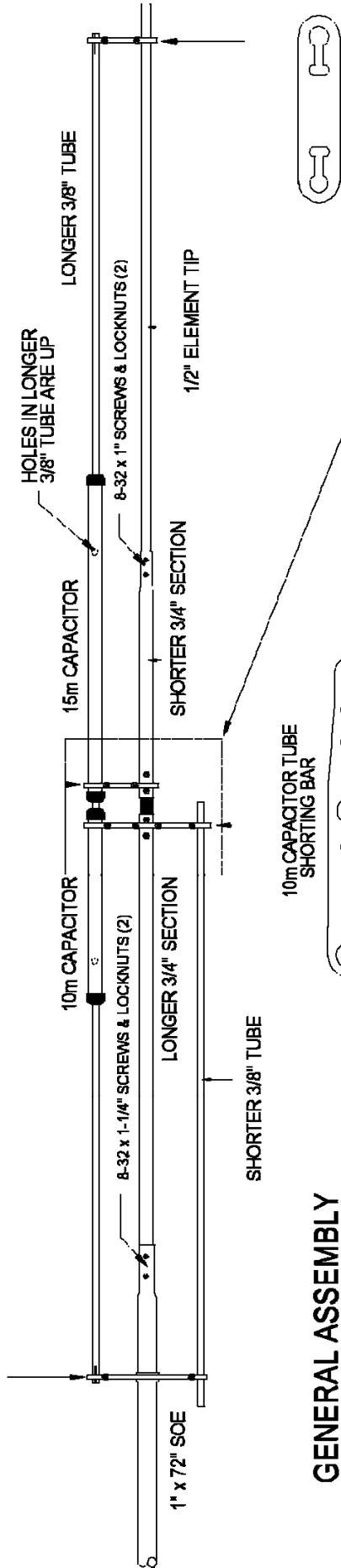

GENERAL ASSEMBLY

1. LAY CAPACITOR ASSEMBLY ON FLAT SURFACE
2. INSTALL 3/4" SOE TUBE SECTIONS
3. ASSEMBLE AND SECURE INNER 8-32 HARDWARE
4. INSTALL & SET 15m SHORTING BAR TO SPECIFIED DIMENSIONS ON LONGER 3/8" TUBE
5. INSTALL 1/2" ELEMENT TIP
6. INSTALL & SET 10m SHORTING BAR TO SPECIFIED DIMENSIONS ON LONGER 3/8" TUBE
7. INSTALL SHORTER 3/8" TUBE SECTION INTO 10m SHORTING BAR AND 10m CAPACITOR SHORTING BAR
8. WITH A MARKER, LABEL THE ELEMENT BY ITS NAME, SIDE, AND INDICATE ITS ORIENTATION WITH RESPECT TO FRONT OF ANTENNA

TERMS:

- STR:** STRAIGHT PIECE OF TUBING
- SOE:** SWAGED ONE END
- SBE:** SWAGED BOTH ENDS
- SWAGE:** A PHYSICAL REDUCTION MADE IN ONE DIAMETER OF TUBING IN ORDER TO FIT OVER.

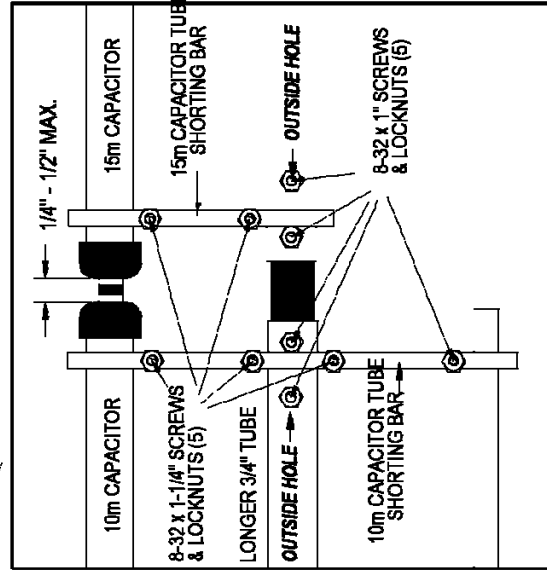

REFLECTOR ELEMENT DIMENSIONS

*ASSEMBLE ON A FLAT SURFACE
 *MARK LOCATIONS ON TUBING
 WHERE SHORTING BARS ARE
 TO BE INSTALLED

TOP VIEW

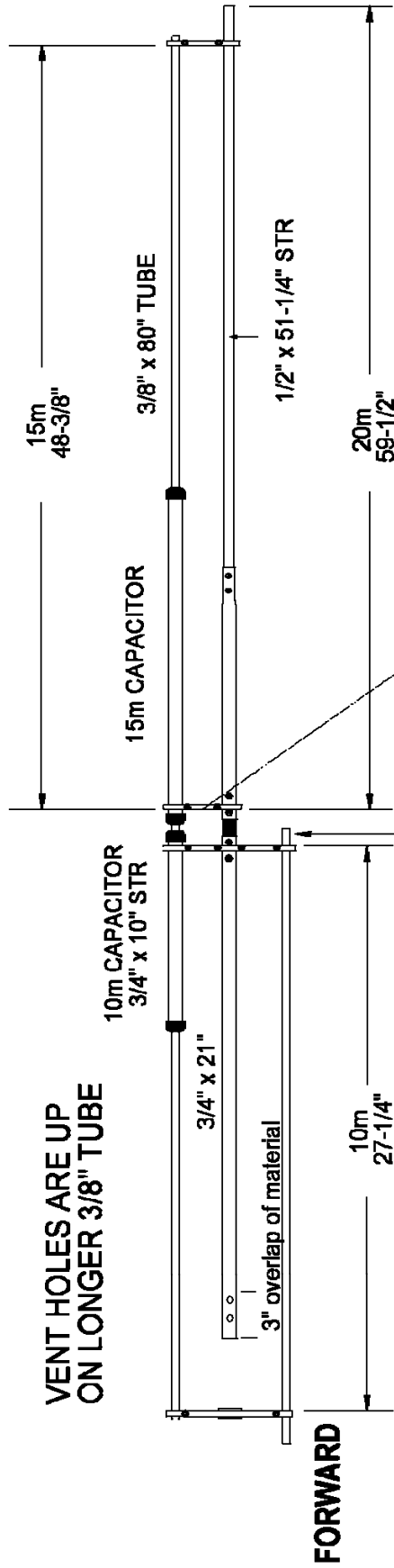

VENT HOLES ARE UP
 ON LONGER 3/8" TUBE

RIGHT SIDE

HOOK TAPE MEASURE HERE WHEN
 SETTING 15M AND 20M DIMENSIONS.

ALLOW TUBE TO
 STICK OUT 1" PAST
 SHORTING BAR

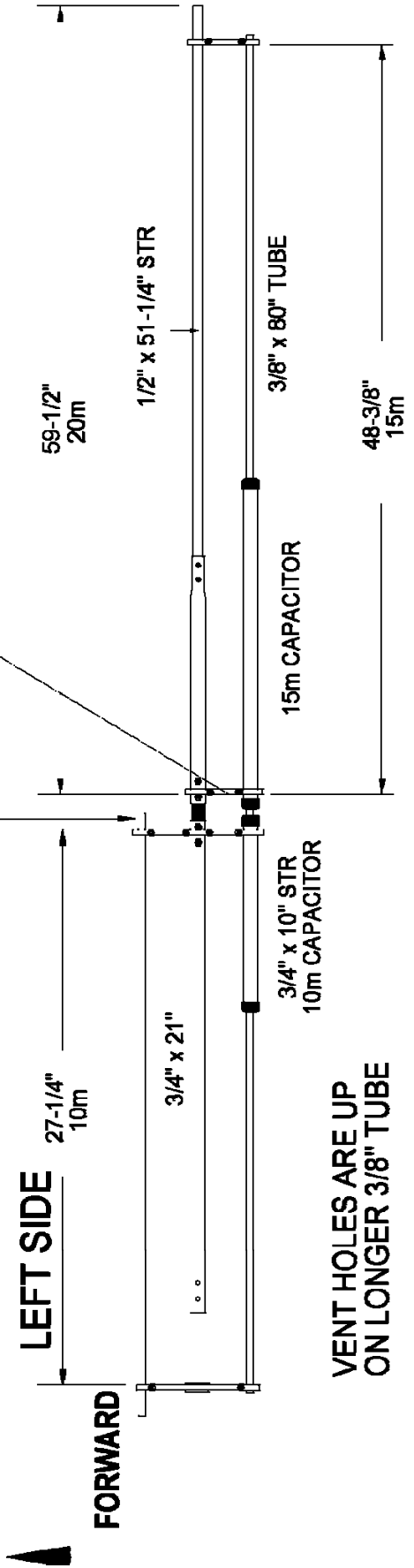

LEFT SIDE

VENT HOLES ARE UP
 ON LONGER 3/8" TUBE

REAR DRIVEN ELEMENT DIMENSIONS

*ASSEMBLE ON A FLAT SURFACE
 *MARK LOCATIONS ON TUBING
 WHERE SHORTING BARS ARE
 TO BE INSTALLED

TOP VIEW

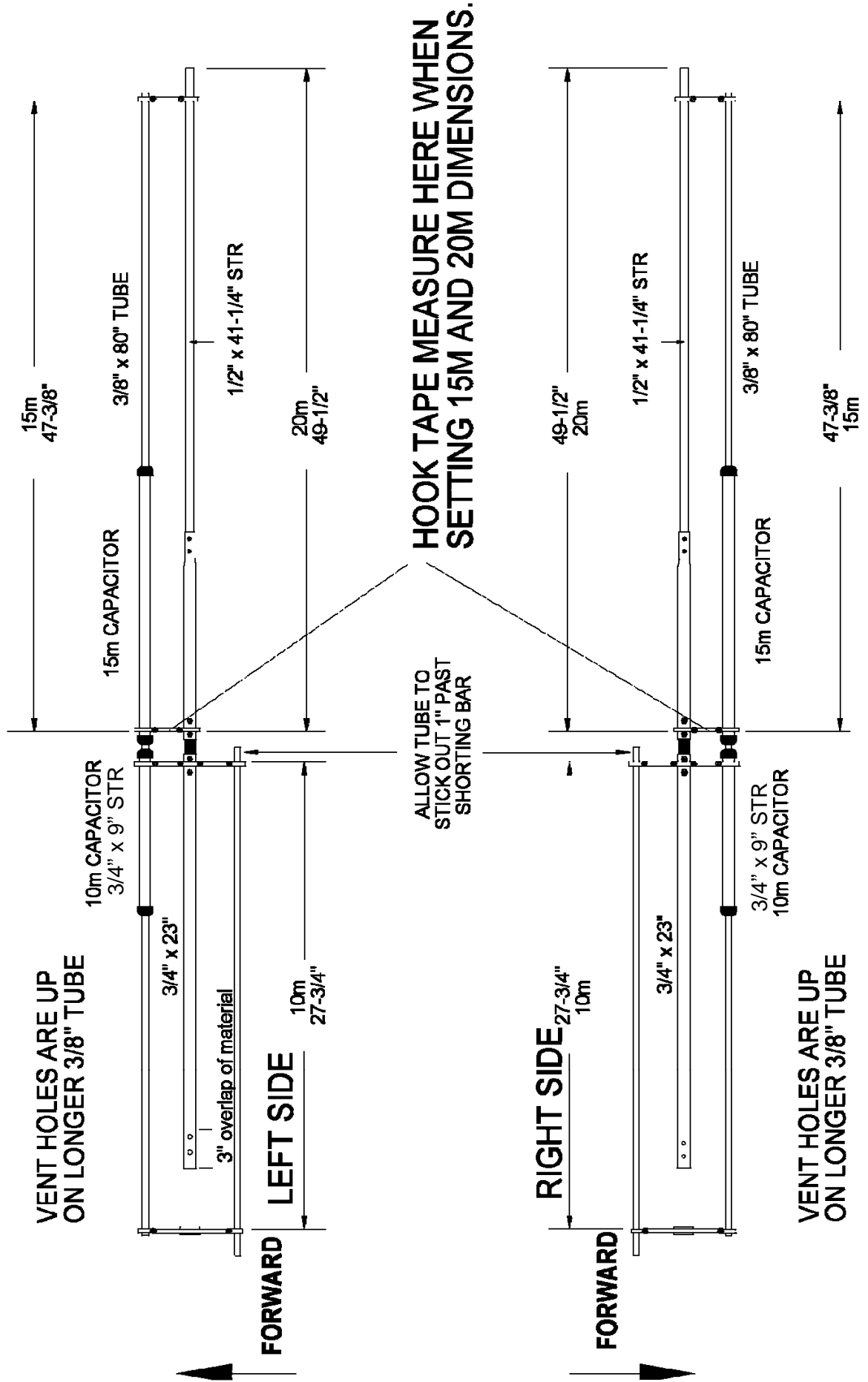

FRONT DRIVEN ELEMENT DIMENSIONS

*ASSEMBLE ON A FLAT SURFACE
 *MARK LOCATIONS ON TUBING
 WHERE SHORTING BARS ARE
 TO BE INSTALLED

TOP VIEW

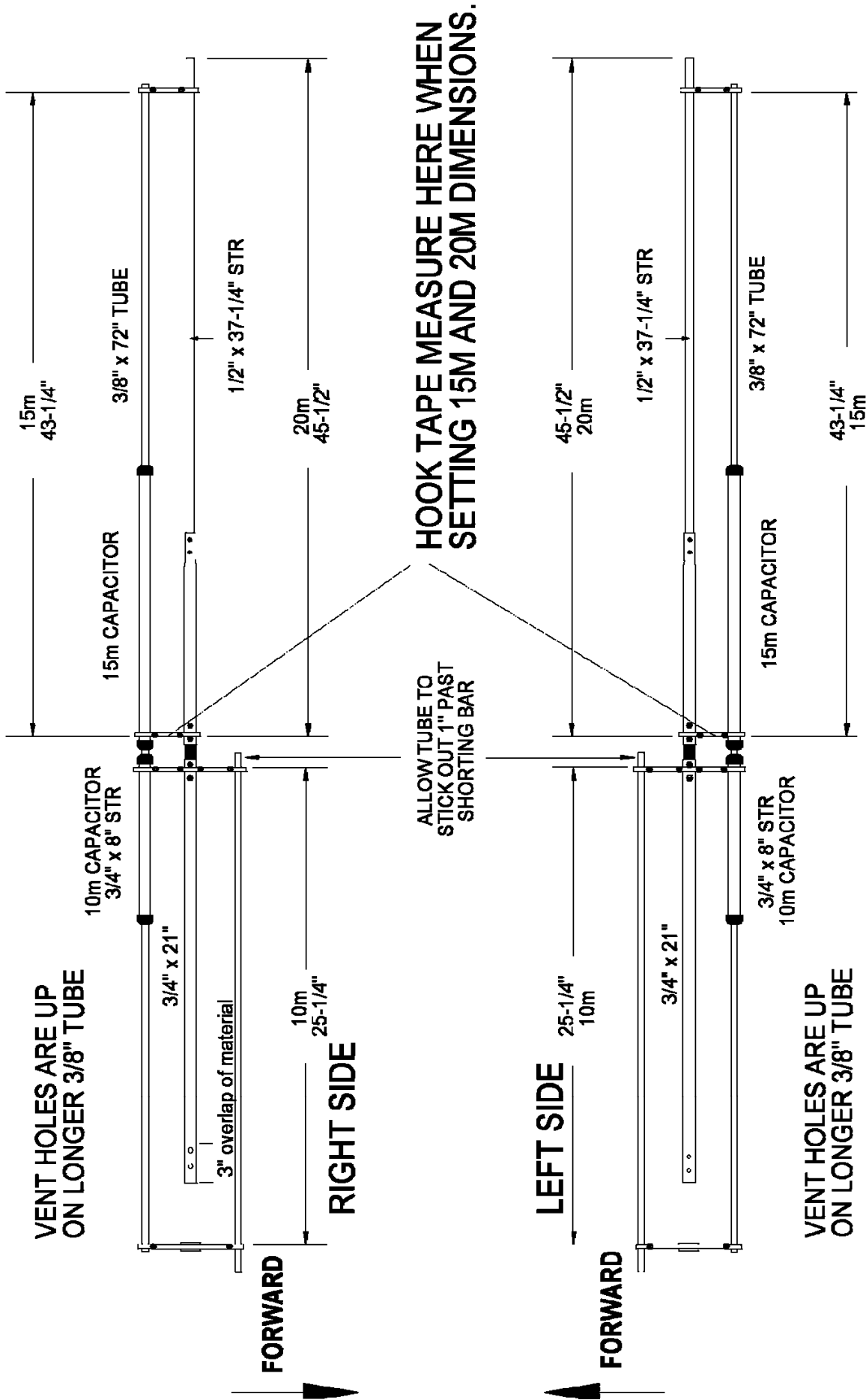

1ST DIRECTOR ELEMENT DIMENSION

*ASSEMBLE ON A FLAT SURFACE
 *MARK LOCATIONS ON TUBING
 WHERE SHORTING BARS ARE
 TO BE INSTALLED

TOP VIEW

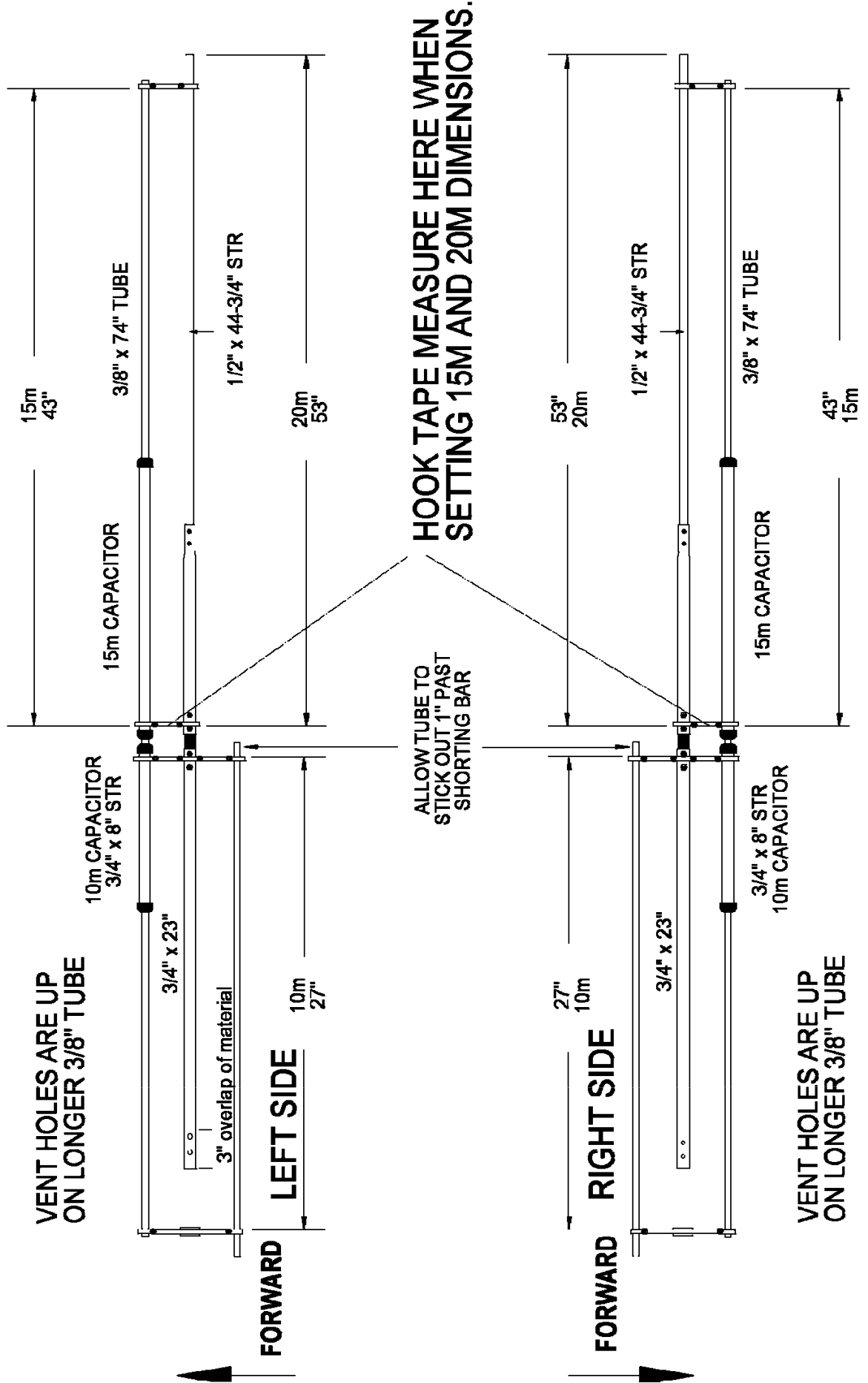

2ND DIRECTOR ELEMENT DIMENSION

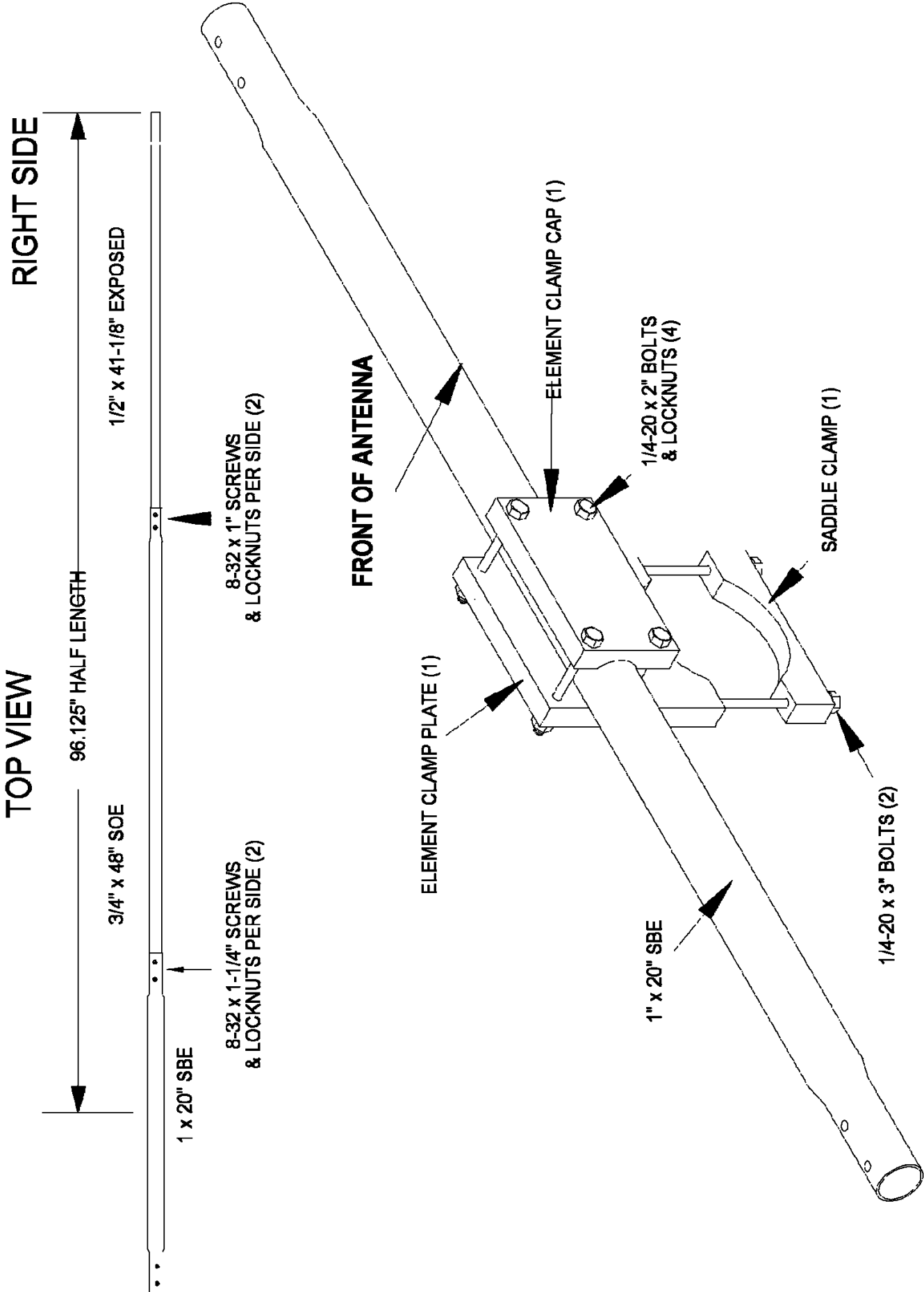

3RD DIRECTOR ELEMENT DIMENSIONS

*ASSEMBLE ON A FLAT SURFACE
 *MARK LOCATIONS ON TUBING
 WHERE SHORTING BARS ARE
 TO BE INSTALLED

TOP VIEW

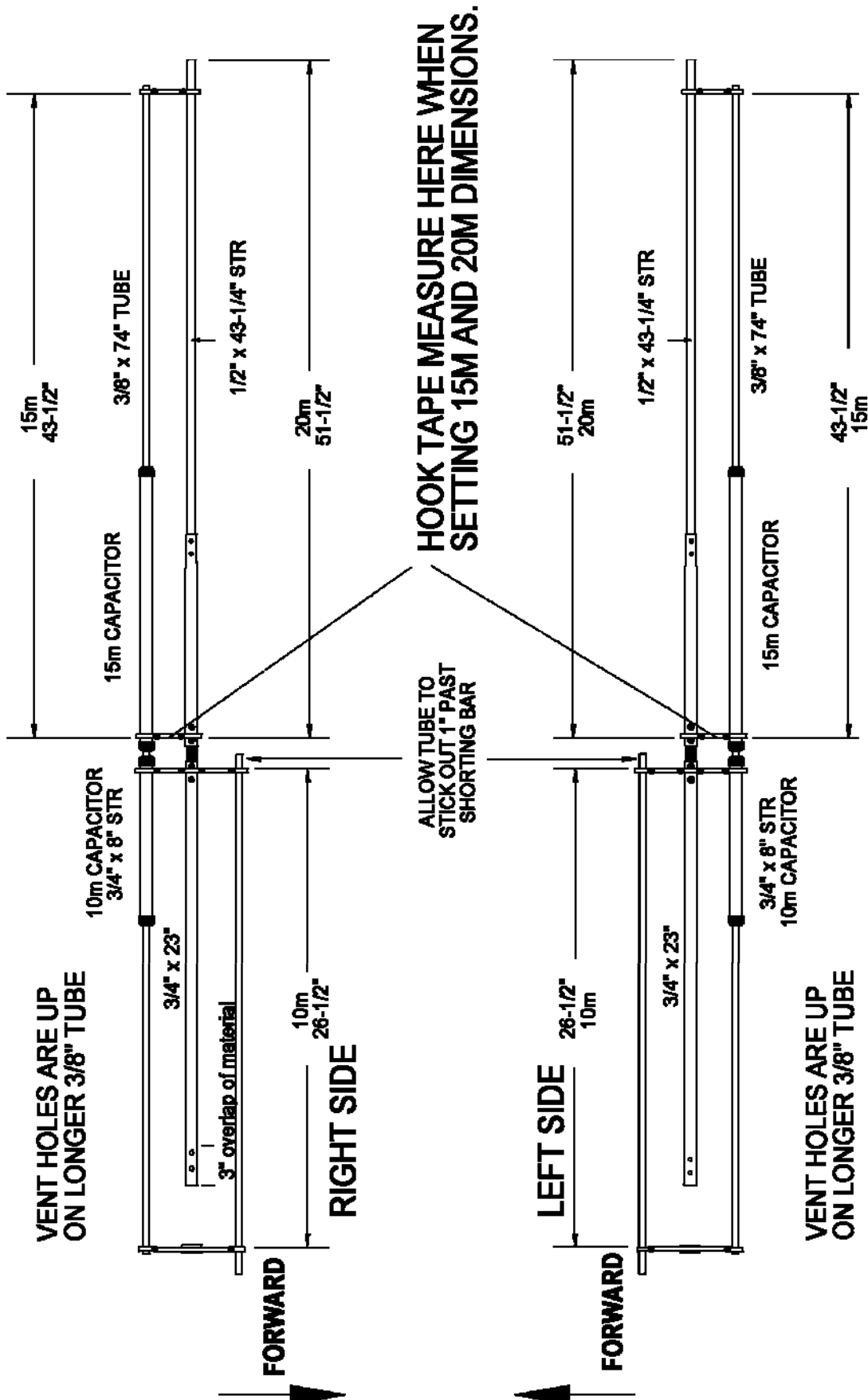

DUAL DRIVEN AND T-MATCH ASSEMBLIES

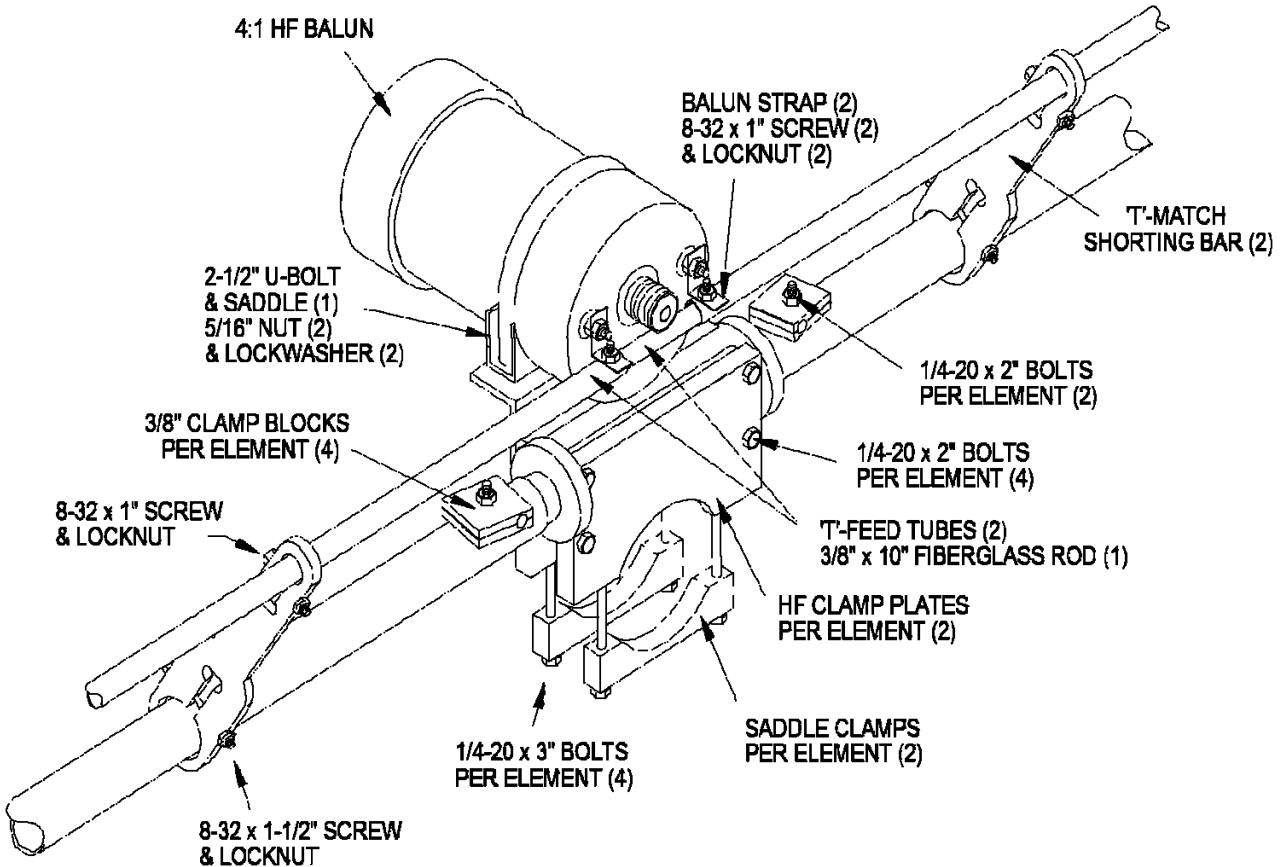
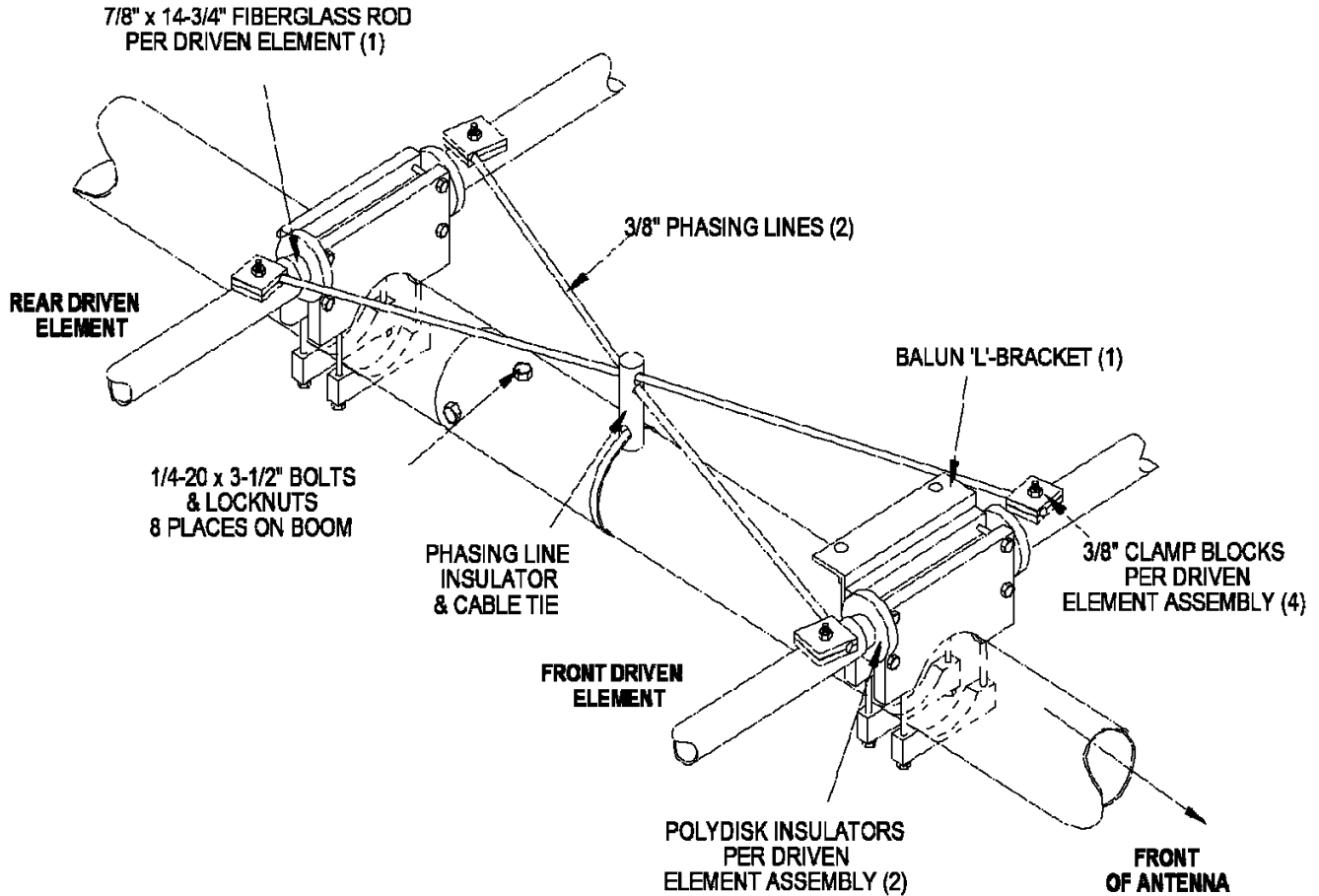

KT36XA DIMENSION SHEET

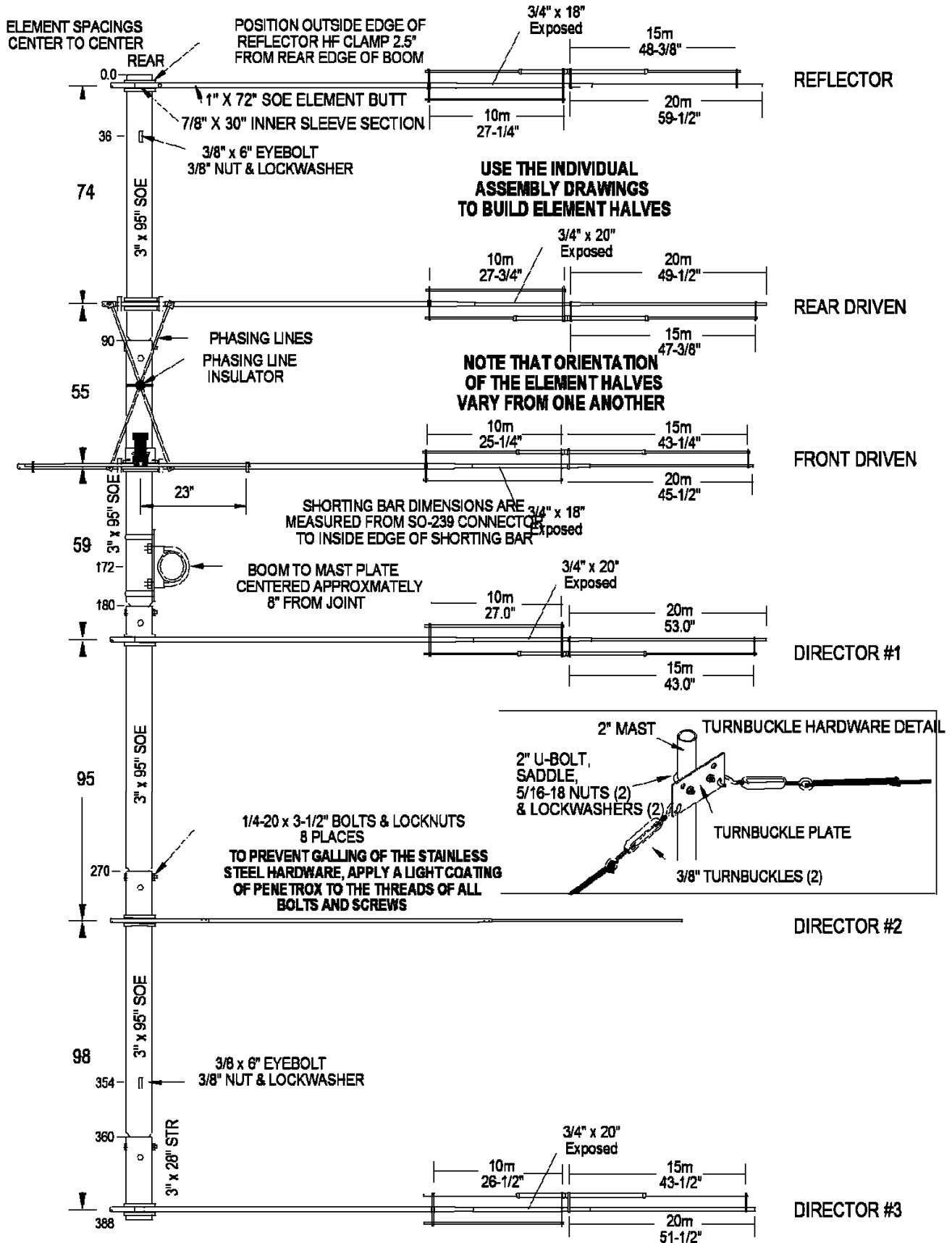

OTHER HALF SECTIONS REMOVED FOR CLARITY

TERMS:
 STR: STRAIGHT PIECE OF TUBING
 SOE: SWAGED ONE END
 SBE: SWAGED BOTH ENDS
 SWAGE: A PHYSICAL REDUCTION MADE IN ONE DIAMETER OF TUBING IN ORDER TO FIT INSIDE OR OVER ANOTHER.

KT36XA PARTS & HARDWARE

DESCRIPTION.....	QTY
Boom sections, 3" x .065" x 95" swaged	4
Boom section, 3" x .065" x 28" straight.....	1
Center sleeve, 7/8" x .058" x 36" STR.....	3
Center Support Tube, 1" x .058" x 20" SBE	1
Element, 1" x .058" x 72" SOE	10
Element, 3/4" x .049" x 48" SOE	2
Element, 3/4" x .049" x 23" SOE	6
Element, 3/4" x .049" x 21" SOE	4
Element, 3/4" x .049" x 12" SBE	10
Capacitor tube, 3/4" x .049" x 8" alum. tube STR.....	6
Capacitor tube, 3/4" x .049" x 9" alum. tube STR.....	2
Capacitor tube, 3/4" x .049" x 10" alum. tube STR.....	2
Capacitor tube, 3/4" x .049" x 16" alum. tube STR.....	10
Element, 1/2" x .049" x 51-1/4" 2	
x 44-3/4"	2
x 44-1/8"	2
x 43-1/4"	2
x 41-1/4"	2
x 37-1/4"	2
'T-Feed Tubes 1/2" x .049" x 23-1/2"	2
Linear Loading Tube, 3/8" x .049" x 80"	4
Linear Loading Tube, 3/8" x .049" x 74"	4
Linear Loading Tube, 3/8" x .049" x 72"	2
Phasing Line Tube, 3/8" x .049" x 57"	2
Linear Loading Tube, 3/8" x .049" x 30"	10
Fiberglass insulator, 5/8" x 6" rod (M2AFG0029)	10
Fiberglass insulator, 7/8" x 14-3/4" rod (M2AFG0030).....	2
Boom to mast plate, 1/4" x 8" x 6" (M2APT0081).....	1
Balun, HF, 4:1	1
Dacron rope, black 5/16" x 30 ft.	1
Cable ties, nylon, large.....	3
Penetrox cup	1
Assembly Manual	1
 IN BAG #1	
Turnbuckle, 3/8"	2
Eyebolt, 3/8" x 6"	2
 IN BAG #2	
U-bolt & saddle, 3"	2
 IN BAG #3	
U-bolt & saddle, 2-1/2" standard	1
U-bolt & saddle, 2" standard.....	5
 IN BAG #4	
Element Clamp Plate, 3/8" x 2-1/2" x 4" (M2AEC0038)	11
Element Clamp Cap, Small HF (M2AEC0037).....	1
 IN BAG #5	
Saddle clamp, 1/2" x 1" x 4"	11

KT36XA PARTS & HARDWARE

IN BAG #6

Clamp Block, 3/8" (M2AMC0261).....	8
Phasing Line Insulator (M2ASO0010).....	1
Turnbuckle plate, 1/8" x 2" x 5" (M2APT0113)	1
Balun 'L'-Bracket, 1" x 1" x 4" (M2APT0015).....	1
Balun Straps (M2ABP0010)	2
Fiberglass Insulator, 3/8" x 10" (M2AFG0010)	1
Poly Disk Insulator, 7/8" dia. Hole (M2ADI0040).....	4

IN BAG #7

Capacitor Caps (M2APL0019).....	40
---------------------------------	----

IN BAG #8

Shorting Bar, 15m (M2ASB0051).....	10
Shorting Bar, 15m capacitor tube (M2ASB0054)	10
Shorting Bar, 10m capacitor tube (M2ASB0050)	10
Shorting Bar, 10m (M2ASB0052).....	10
'T' Match Short. Bar 1/4"x1-1/4"x3-13/16" (M2ASB0055).....	2

IN BAG #9

Shorting Bar Insulator, Delrin, Black 1-1/2" (M2ASB0053)...	10
---	----

IN HARDWARE BAG #10

Nut, 3/8-16 SS.....	6
Lock washer, 3/8" split ring SS	6
Nut, 5/16-18 SS.....	12
Lock washer, 5/16" SS	12
Bolt, 1/4-20 x 3-1/2" SS	8
Bolt, 1/4-20 x 3" SS	22
Bolt, 1/4-20 x 2" SS	28
Bolt, 1/4-20 x 1-1/2" SS	6
Nut, 1/4-20 locking, SS.....	64

IN HARDWARE BAG #11

Screw, 8-32 x 1-1/2" SS	2
Screw, 8-32 x 1-1/4" SS	74
Screw, 8-32 x 1" SS	118
Nut, 8-32 locking, SS.....	194

BOX #1 PARTS & HARDWARE

BOOM SEC. 3" W/ EYEBOLT HOLES.....	2
1 X 72" SOE	10
BUNDLE, 3/4 X 23" (6) & 3/4 X 21" (4) SOE	1
BUNDLE, 3/4 X 12" SBE	1
BUNDLE, ALL 1/2" TUBES	1
TURNBUCKLE / EYEBOLT BAG	1
ODDBALL PARTS BAG	1
CAPACITOR CAP BAG	1
SHORTING BAR BAG	1
BLACK DELRIN INS. BAG.....	1
BALUN, HF, 4:1.....	1
DACRON ROPE.....	1
ASSEMBLY MANUAL.....	1

BOX #2 PARTS & HARDWARE

BOOM SEC. 3" SOE, NO HOLES.....	2
BOOM SEC. 3" X 28" STRAIGHT.....	1
ODDBALL TUBE BUNDLE	1
ELEMENT, 3/4 X 48" SOE	2
CAPACITOR TUBE BUNDLE.....	1
SHORT 3/8" TUBE BUNDLE.....	1
MED. & LONG 3/8" TUBE BUNDLE	1
FIBERGLASS INSULATOR, 7/8 X 14-3/4"	2
BOOM TO MAST PLATE, 1/4 X 6 X 8"	1
SHORT FG ROD BAG	1
3" U-BOLT BAG	1
2-1/2" & 2" U-BOLT BAG	1
CLAMP PLATE BAG	1
SADDLE BAG	1
1/4-20 HARDWARE BAG	1
8-32 HARDWARE BAG	1
CABLE TIES	3