

MFJ-1848

6,10,12,15,17,20,30,40 METER

HEX BEAM ANTENNA

INSTRUCTION MANUAL

**CAUTION: Read All Instructions
Before Operating Equipment**

MFJ

300 Industrial Park Road
Starkville, MS 39759 USA
Tel: 662-323-5869 Fax: 662-323-6551

Introduction

Thank you for purchasing the MFJ-1848 eight band HF antenna. Your new antenna is composed of High strength material for excellent rigidity and light weight. It has good bandwidth and minimum SWR on all eight bands. This antenna is fairly lightweight for its size and can be turned by a medium size rotator.

Preparation

This antenna, although it is not heavy, is very cumbersome for one person to handle. It is a good idea to have a temporary mast on the ground for assembly so that you can reach some of the parts that are higher up on the antenna. Once assembled you will need to get it a little higher (10) ft or so for tuning. All bands will not tune correctly if the antenna is on the ground. 40, 30 and 20 meters will be affected most of all. If you tune the antenna close to the ground, the frequency will change once the antenna is raised. This antenna is very large once assembled. Make sure you have the space to maneuver the antenna to its final location before starting. The antenna assembly will go quickly and is fairly easy but take your time anyway. As with all antennas, safety glasses are recommended during the assembly and tuning. We don't want you to "Poke your eye out". Pick a clear open spot and assemble the antenna away from other people. Do not allow children in the assembly area. Only the people involved in the construction should be near. If you plan to assemble the antenna over grass, be prepared to go on a "lawn safari" to find the hardware that you drop. It's not a question of if, but when you drop something. A few extra parts have been included in the parts pack for just such an adventure. Assembly can be done by one person but when the antenna is to be mounted or moved, plan to have a friend help. It is not wise to attempt to install any antenna without help. Once completed, this antenna can seem light weight enough for one person to handle but it is very large and you can easily lose your balance trying to turn or tilt the antenna. Don't rush. The more time you put into the antenna, the happier you will be with the results.

WARNING

KEEP THIS ANTENNA
AWAY FROM POWER LINES

Never mount or move any antenna where it can come into contact with power lines. If this antenna comes into contact with power lines, it can KILL you. Never mount any antenna where if it fell it could come into contact with power lines.

What's In the box

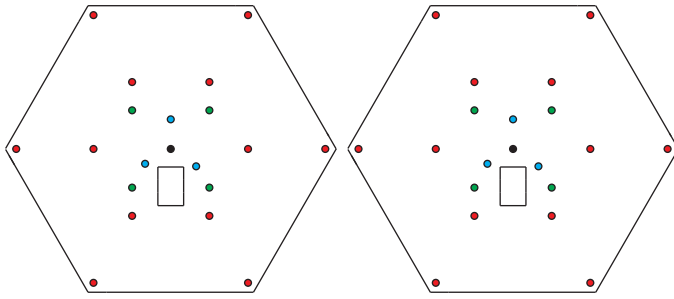

2 mounting plates

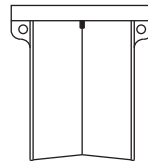

Lower Mast Support



Lower Mast Clamp

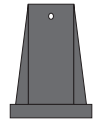

Upper Support

6 x 1 inch
Fiberglass Poles

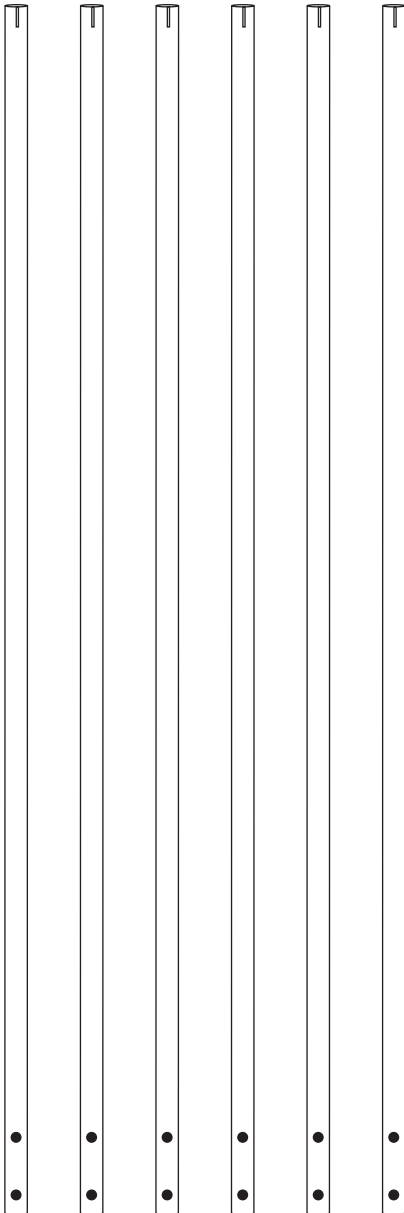

6 x 3/4 inch
Fiberglass Poles

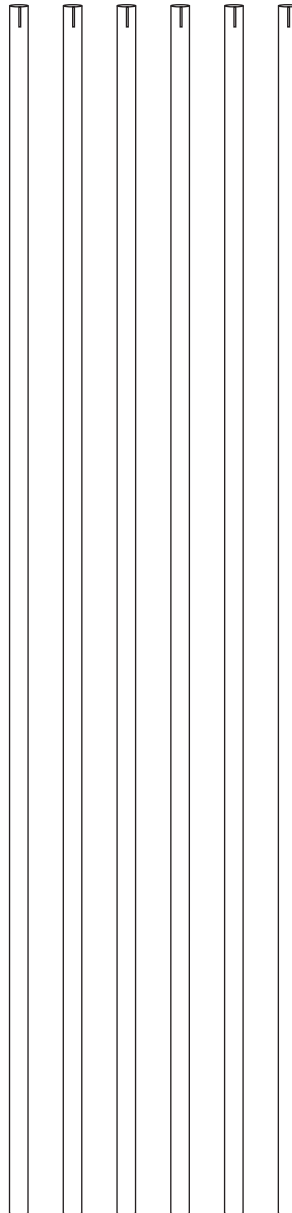

6 x 1/2 inch
Fiberglass Poles

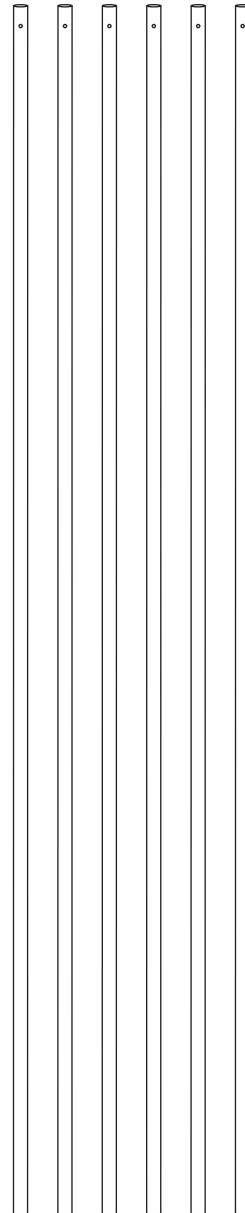

1 x 1-1/4
Fiberglass Pole



Feed line
Tubes

What's In the box

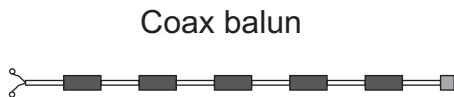
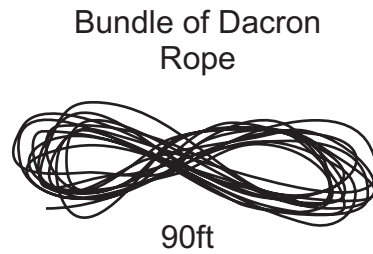
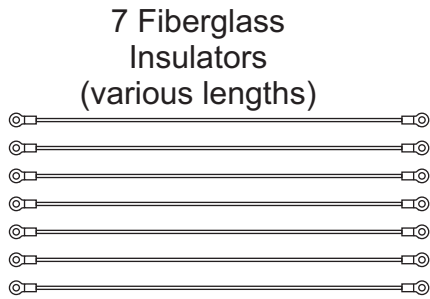
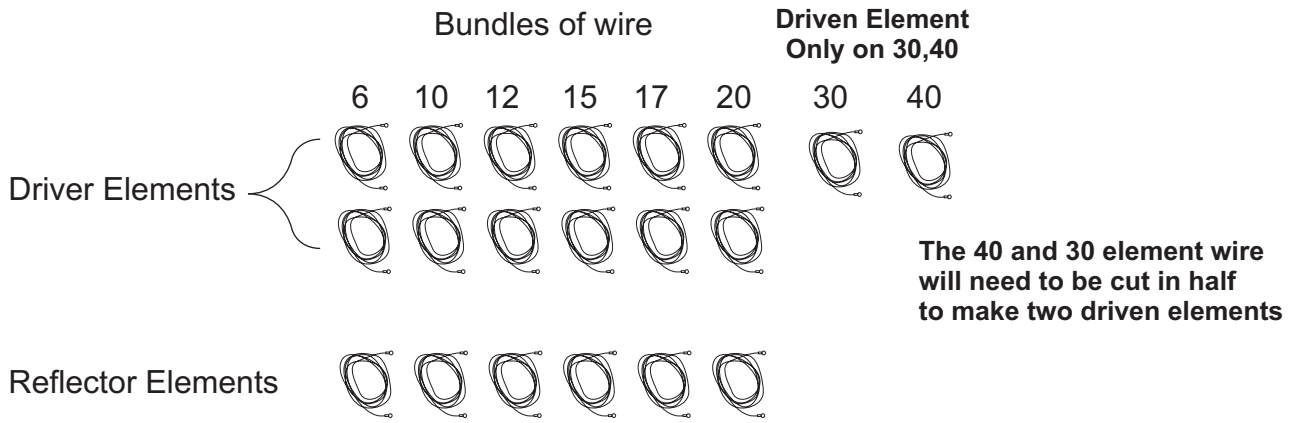

Plate Assembly

Take one of the mounting plates and mount the top support to it using the 1/4-20 x 1 inch bolts. The plate flange should be on the opposite side. Align three of the holes in the support with three holes in the center of the plate. There is a small hole in the side of the insulator where the tube will slide in. Make sure this hole is on the opposite side of the square hole in the plate. Use a split washer and nut on the other side.

Mount the lower mast support on the other plate opposite of the flange using the four holes in the same manner. Align the large square hole in the plate with the large hole in the mast support. This is a path for the coax balun to connect to the antenna. Tighten all bolts securely.

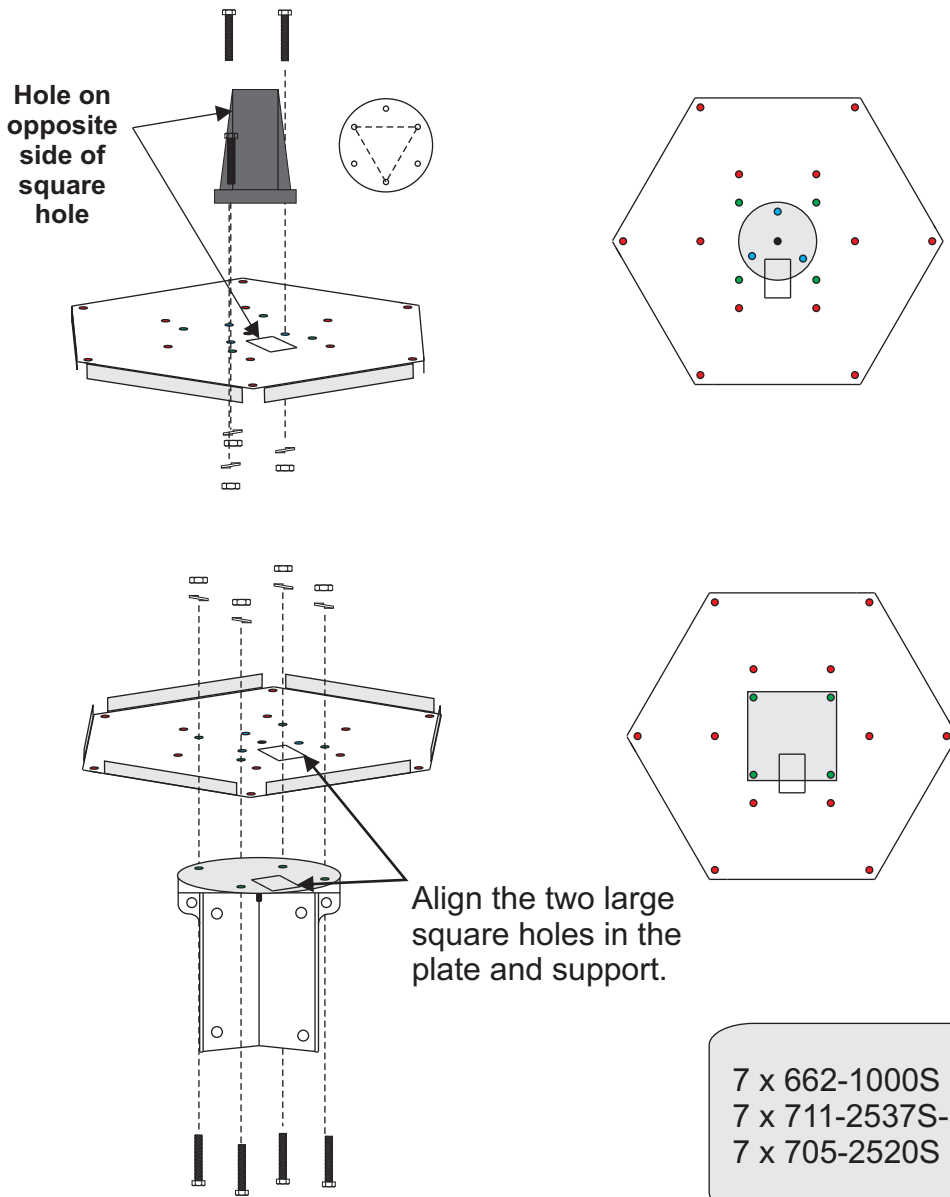
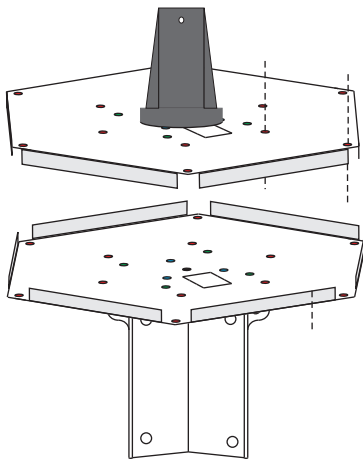
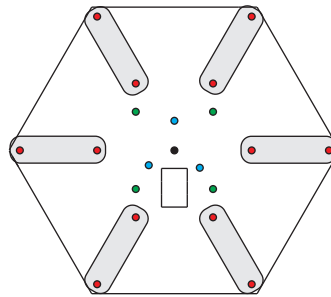

Plate Assembly

Insert a 1x72 Fiberglass tube between the two brackets and use the 1/4-20 bolts nuts and split washers to secure them together. Make sure the large square hole in each plate is aligned. Run the bolts through the holes in the fiberglass tube. Don't tighten until all six tubes are in place. Do not over tighten the bolts. It will crush the tubing.



12 x 662-1500S 1/4-20 x 1-1/2 bolt
12 x 711-2537S-SL 1/4 split washer
12 x 705-2520S 1/4-20 hex nut



Once the tubes are secure in between the plates, it will be okay to let the entire assembly lie on the ground and let it rest on the lower mast bracket. This will make the rest of the antenna tubes and wires easy to get to without a ladder.

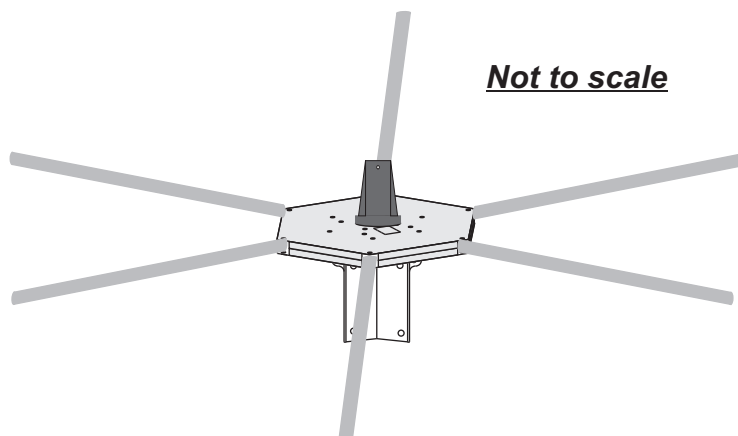

Element Support Assembly

Insert the remaining tube sections into the base assembly.

Insert the 3/4 tube 12 inches into the 1 inch tube and secure with a #10 hose clamp.

Insert the 1/2 tube 12 inches into the 3/4 tube and secure with a #6 hose clamp.

Make sure that the hole in the 1/2 tube is at the end and is vertical

Repeat this for all 6 elements.

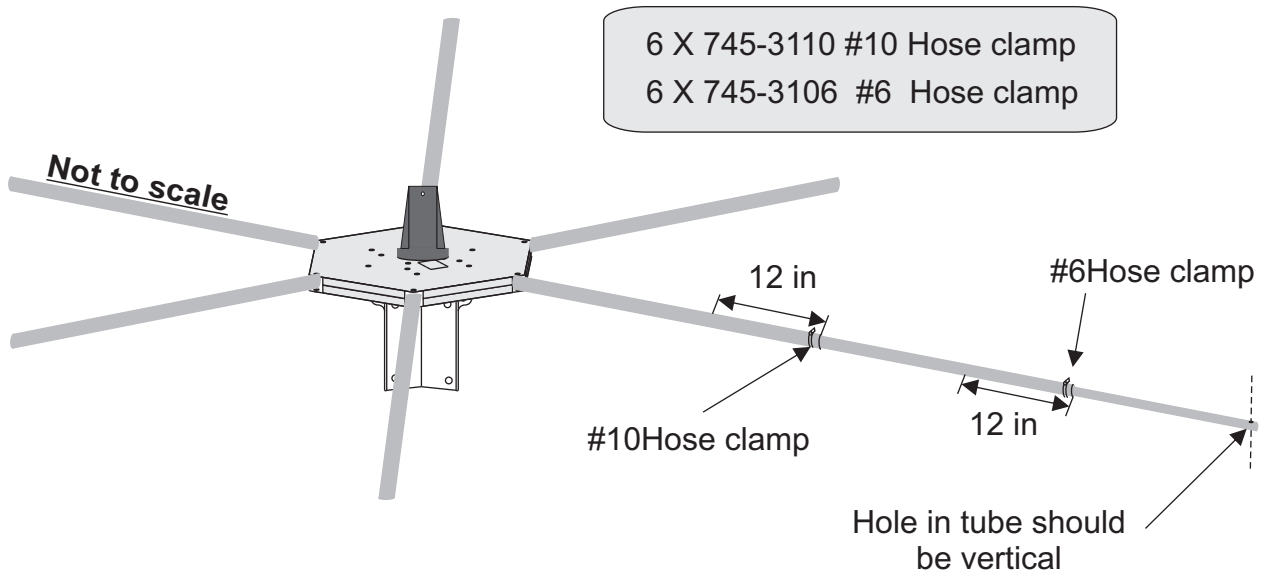

lower mast support

2x 5038200 U-bolt
8x 1/4 split washer
4x 1/4-20 nuts
1x 5/16x3/4

Feed Tube Assembly

Take the two feed tubes and slide them into the feed tube insulators. Place one insulator above the hole in the tubes for each band. The top of the tube has the holes spaced farther apart for 30 and 40 meters. Twist the tubes as they are being inserted, this will make it easier. The holes are tight to maintain a strict spacing of the tubes to achieve the correct impedance from top to bottom of the feed tube. If you're having trouble, check for burrs in the plastic and remove them if needed. Insert the fiberglass support tube by laying the insulators on a flat surface to keep them from spinning as you spin the fiberglass tube into the insulators. Be patient, keeping each insulator vertical will help. If the insulator is allowed to tilt, it will lock in place and not allow the tube to move.

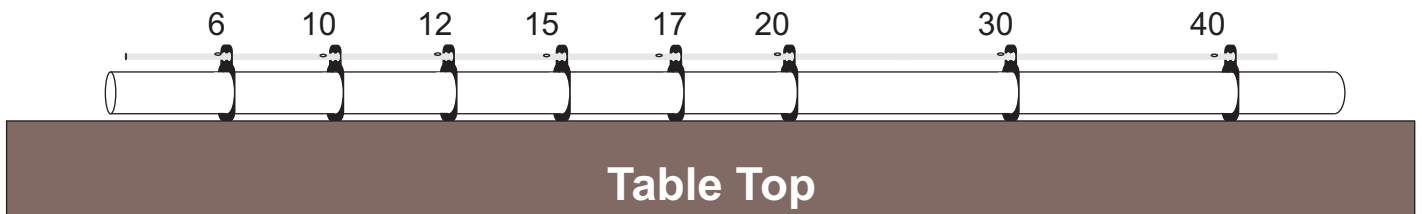

8 x 736-1846-FI Feed insulator
5 x 736-1845-W ABS washer
3 X 705-2520S-NL 1/4-20 Nylon lock nut
1 X 662-3250S 3-3/4 BOLT
1 X 736-1845-RR Rope Ring

Assemble the rope ring as shown below. Use the nylon lock nuts and long bolt to space the washers. Make sure that the last lock nut is threaded far enough onto the bolt for the nylon to engage the bolts thread.

Rope Ring

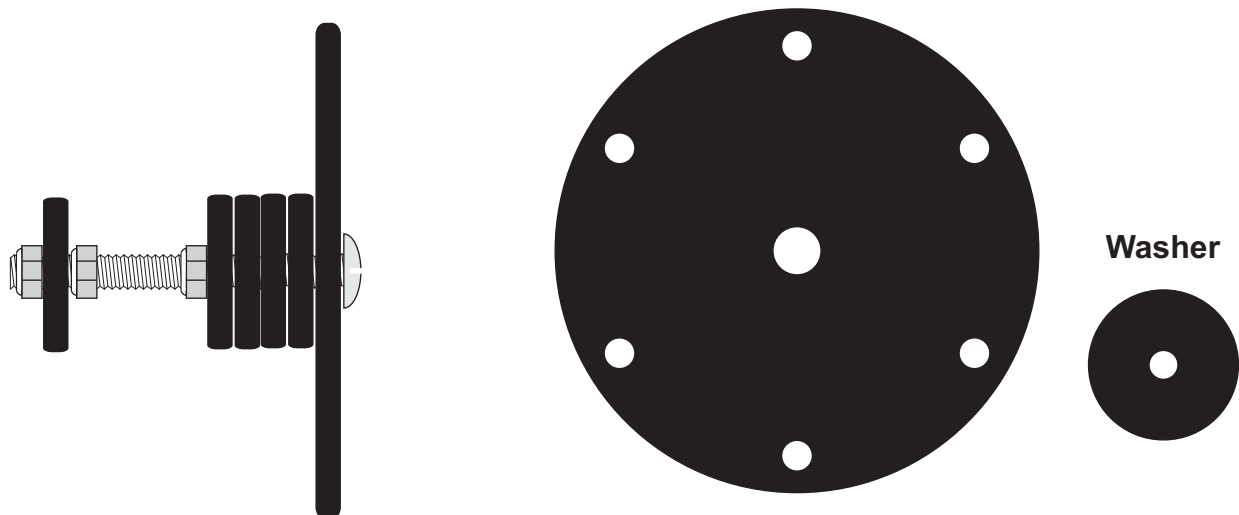

The top feed guide should go below the feed point.
Install a #16 hose clamp below to support the tubes

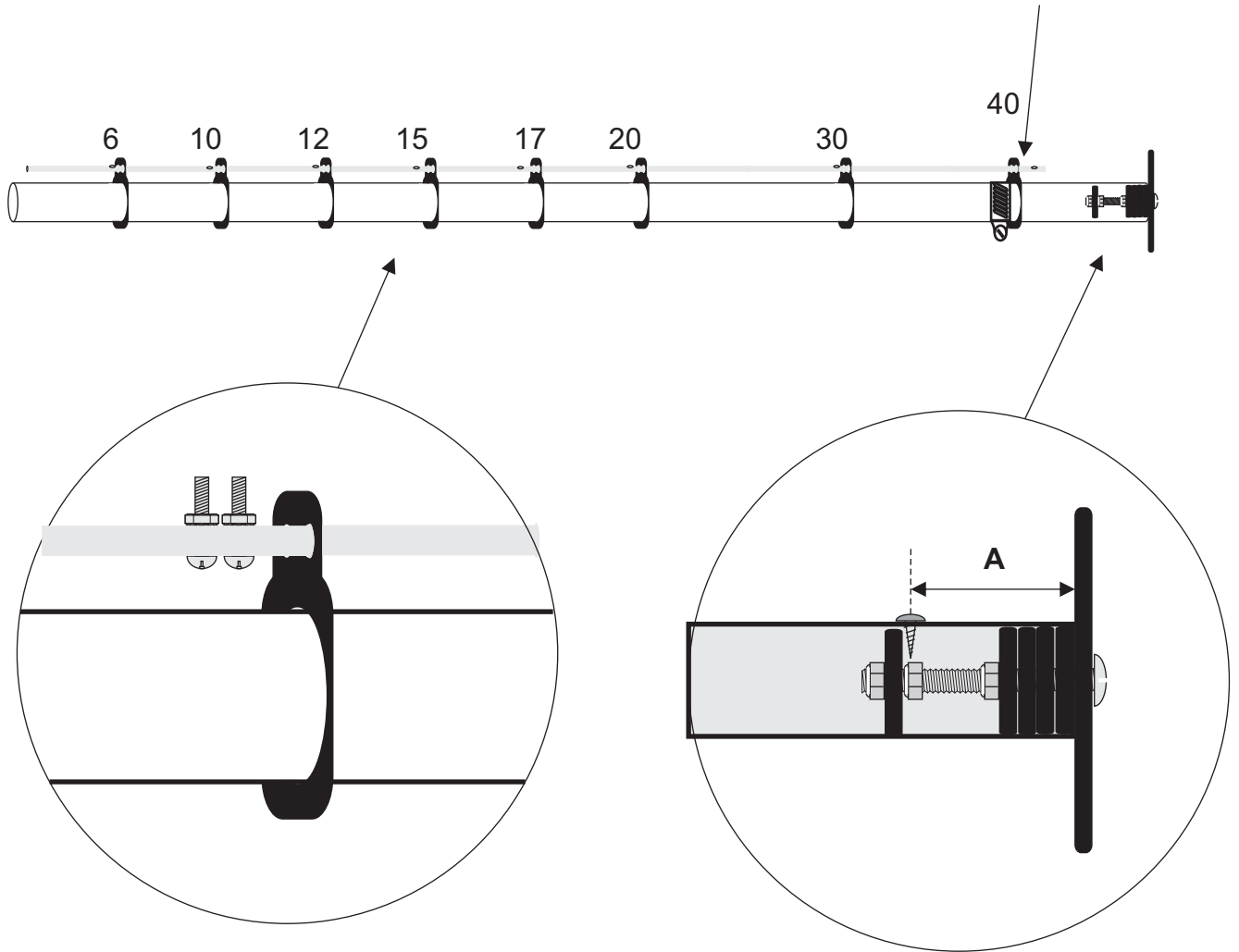

Rotate the feed tube slightly to insert the screw from the bottom. Do this for all the holes in the feed tube.

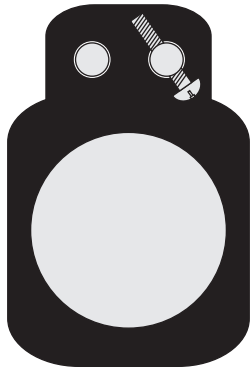

Measure distance "A" before inserting into support tube. Mark tube so that screw is just above last ABS washer. This will lock the rope ring in place. You may drill a pilot hole if you wish for the screw but it will penetrate the fiberglass without one.

- 3 x 736-1846-FS Feedline spacers
- 18 x 656-0750 6-32 x 3/4 screws
- 18 x 705-0632S-K 6-32 locknuts
- 1 X 656-0500S-A #6 self tapping screw

Insert the support tube into the support bracket.
Make sure the feed tubes line up with the square
hole in the mast plate. This is where the feed line
will attach.

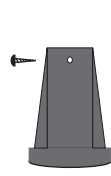

Locate the hole in the support bracket
and drive a #6 self tapping screw through
the hole and into the fiberglass.

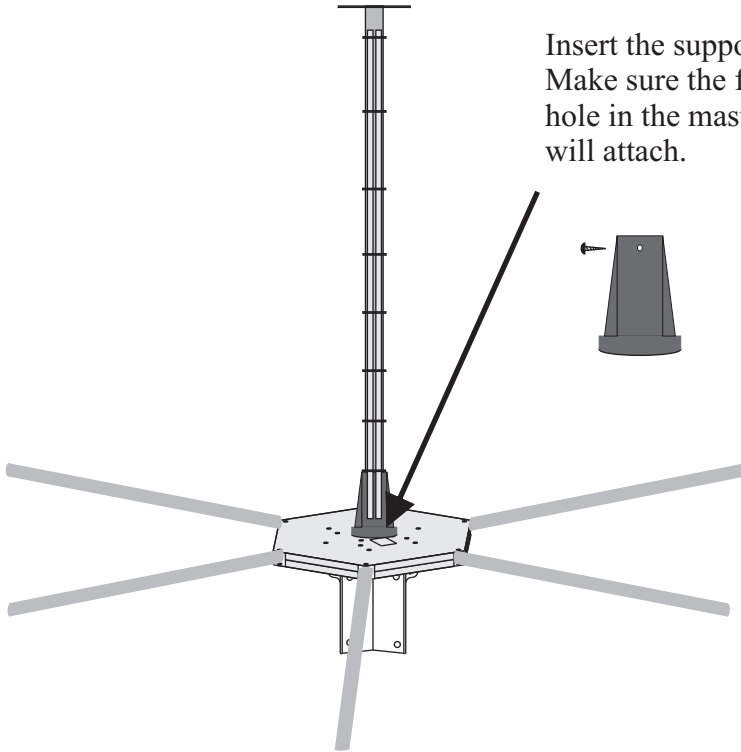

Tension Rope Attachment

Cut 6 sections of Dacron rope 172 inches long. Loop one end through a hole in the rope ring. Leave 3 inches excess rope and secure this with 3 ABS cable ties. Loop the other end around the tube clamp that has been assembled using the spacer.

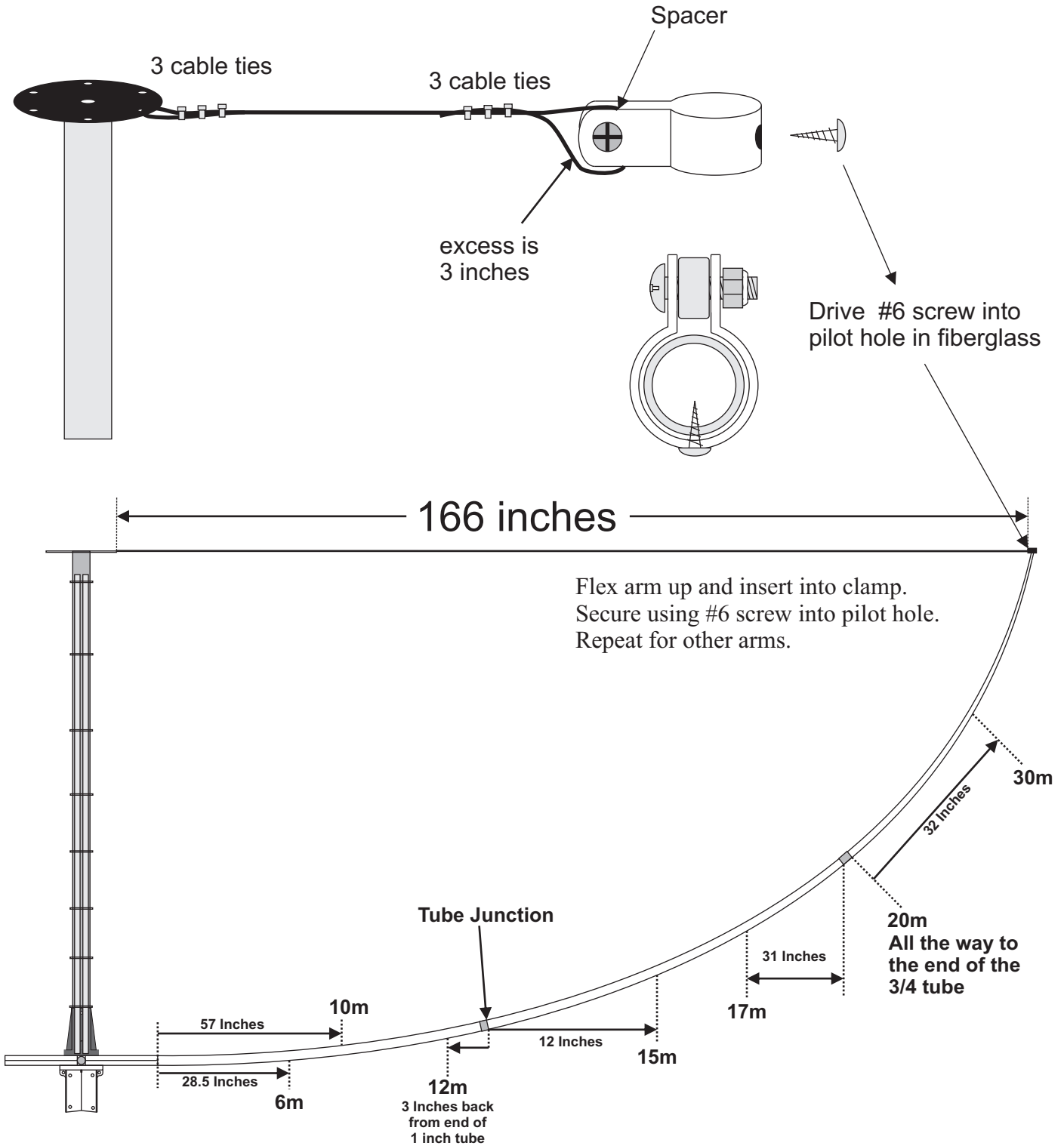

Wire Element Clamps

The wire guides are assembled as shown below. Use a 5/16 nut driver or a flat head screwdriver to unscrew hose clamp and insert band through the slotted hole. Note that one hole in the ABS plastic is larger than the rest. This is to allow the eyellet to pass through the hole. Put the hose clamp band around the element and restart the band in the screw housing by slowly turning the screw while inserting. The inner 1 inch tubing will require a #10 hose clamp. The 3/4 and 1/2 tubing will use a #6 hose clamp.

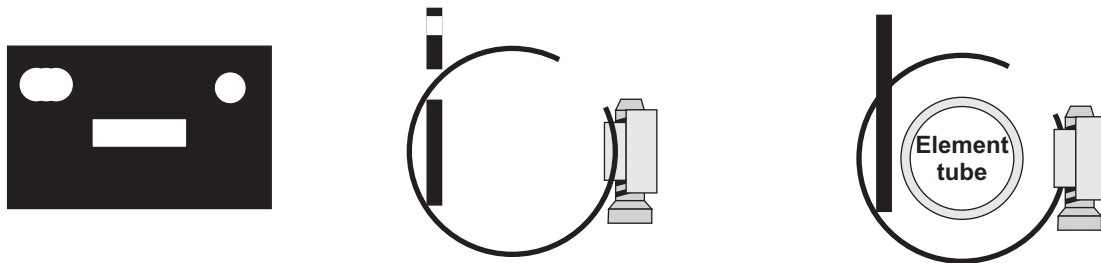

Extra hole can be used for ice supports if desired.

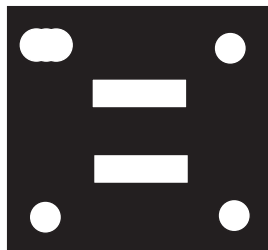
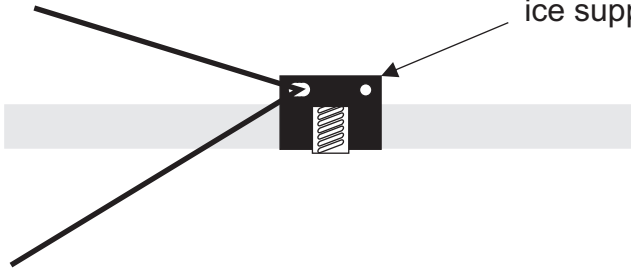

If your wire guide looks like this, then loop the hose clamp through both slots. the extra holes at the bottom will not be used.

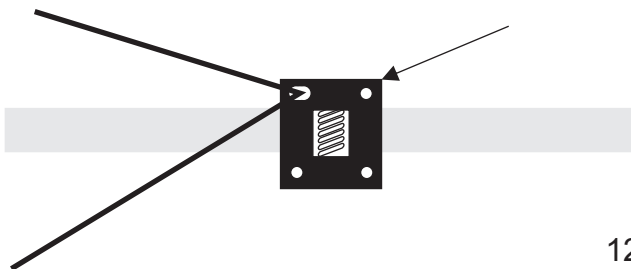
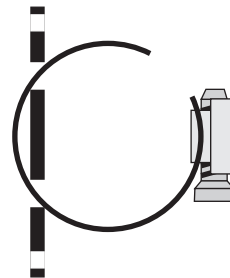

Start the six meter wire on the second feed point from the bottom. Feed the two driven elements as shown. Attach the reflector and driver wires to the insulators using the 6-32 screws and locknuts.

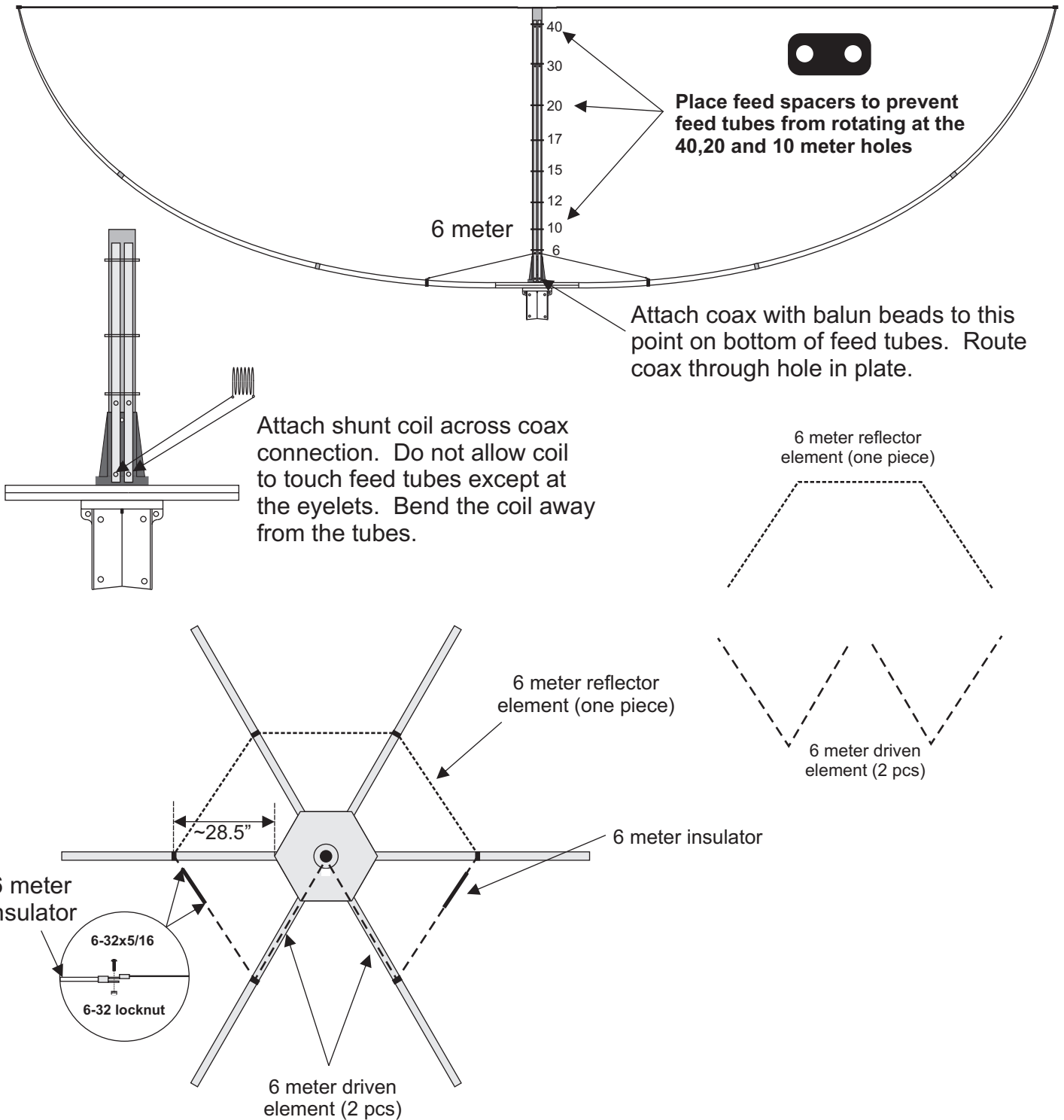

Install the six meter wires as shown. Each wire guide should be about 28.5 inches from the edge of the hub. This distance can vary to affect the tension on the wires. Adjust the hose clamp distance to allow the wire to be loose enough to flex with the element arms in windy conditions. A little sag doesn't affect performance and prevents stress on the connections. The left and right driven elements are attached to the left and right feed tube respectively.

Repeat the same procedure for installing the 10-20 meter elements onto the antenna. The spacing between the elements is shown below. To make measuring easier, distance is given from joints in the fiberglass instead of from the center of the mast. Tighten the wire guide just enough to allow it to slide up and down the fiberglass arm. This will make it easy to adjust the tension of the wires once they are in place. Remember that the distance measurements are close but final adjustment may be needed to get the tension of the wire correct. The 6-20 meter wires are all installed in the same configuration. A “W” for the two driver elements and a \sphericalangle for the reflector. All six arms use the same spacing.

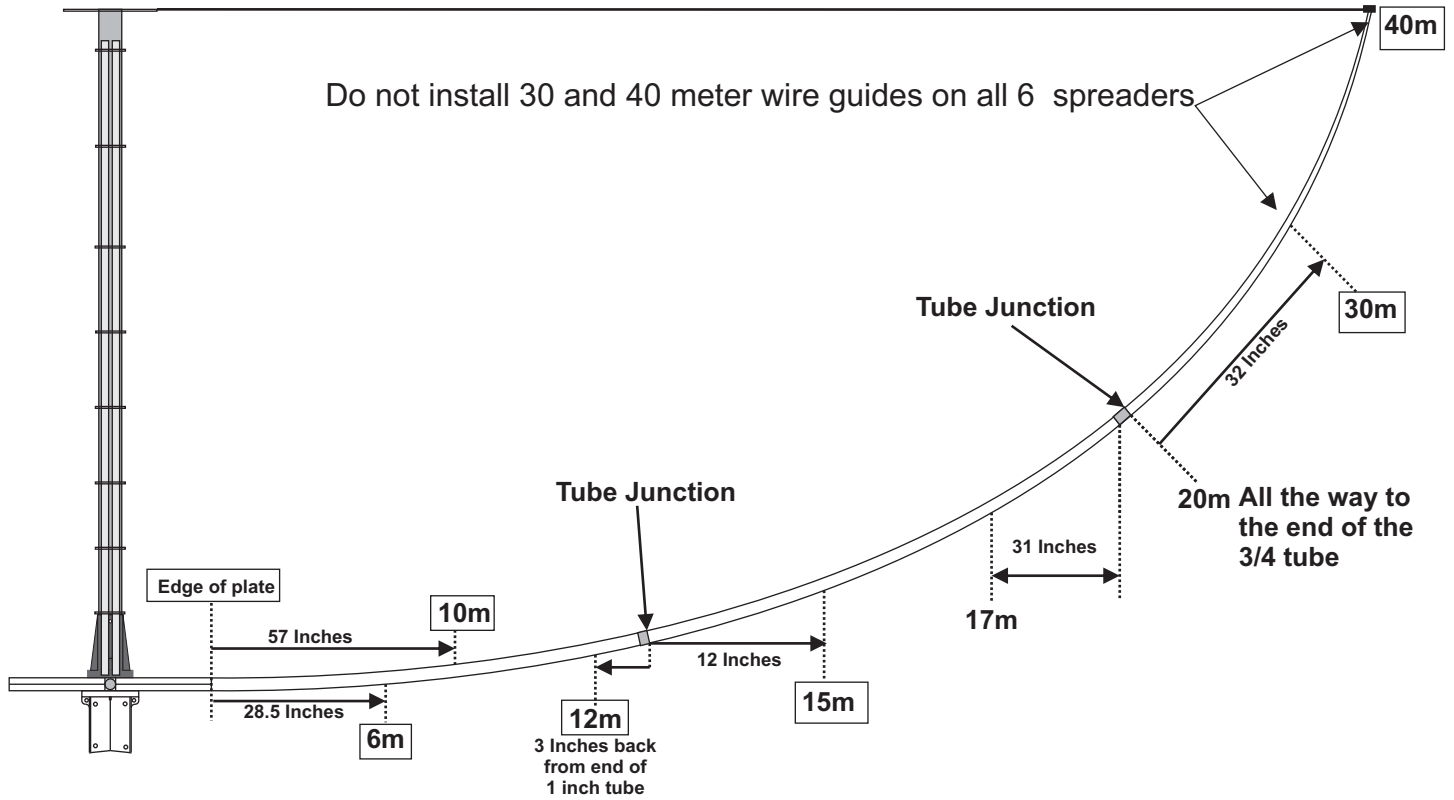

The 30 meter wire installation will be different. It only uses a driven element. Route the wire as shown on the 30 meter wire guides. The wire supplied is in one piece with an eyelet on each end. Unroll the wire and fold it in half. Cut it in the center to make two element wires.

Terminate the wire temporarily by twisting it back on itself. This allows you to unwrap the wire and change the length for tuning. After tuning, the wire can be secured using a 6-32 x 5/16 screw and locknut through the hole in the wire guide.

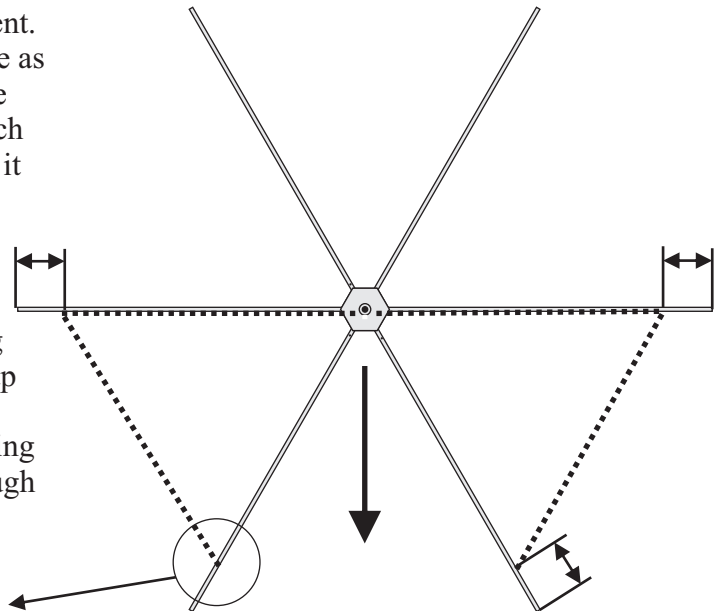
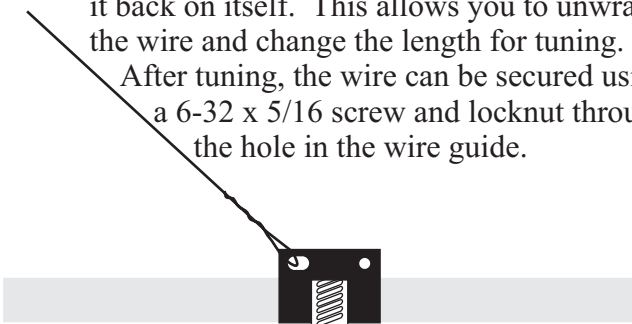

Tuning of the 30 meter wire is achieved by moving the wire guides inward to shorten the total length of the wire. This will move the swr dip higher. After tuning, remove excess wire.

Cut the 40 meter wire just like the 30 meter wire. Unroll it and fold it in half to cut. The 40 meter wire installation is on the other side of the antenna. The wire runs parallel to the 30 meter wire until it reaches the end of the fiberglass tube and then it turns away in the opposite direction. The elements form a loop with a 12 inch fiberglass insulator installed at the center between the two element arms. The 40 meter swr dip should be below the band when all the wire supplied is used and the wire guides are at the end of the element arms. To raise the dip frequency, cut the wire a small amount evenly on each side and retest. Notice how much the dip moves for the amount of wire removed. Use this as a rough guide as to how much wire will need to be removed. Moving the wire guides inward will allow you to shorten the wire to make a smaller loop. Do not allow the ends of the wire to fray. This will cause arcing and may melt the ends of the wire at high power levels. The shunt coil at the feed point of the antenna must be stretched or compressed to achieve a minimum swr on 40. When tuned properly, the shunt coil will not affect the rest of the bands.

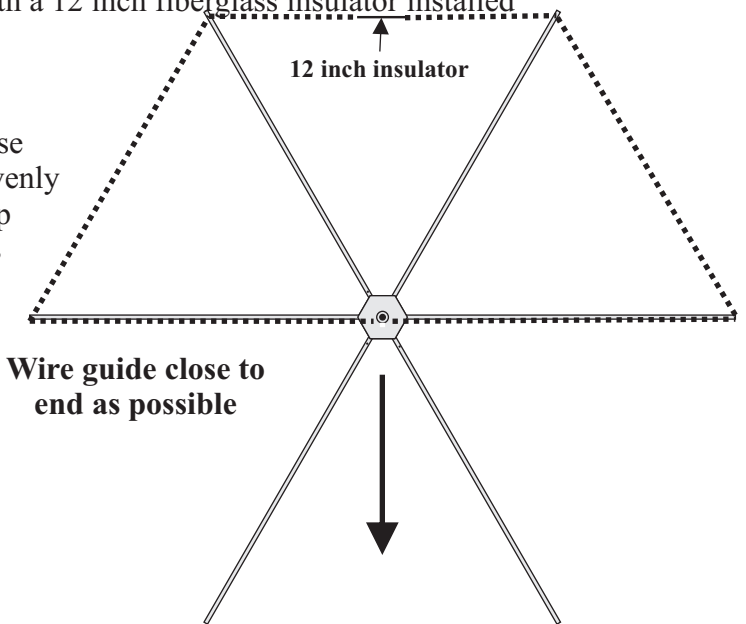

Insulator size exaggerated to show detail.

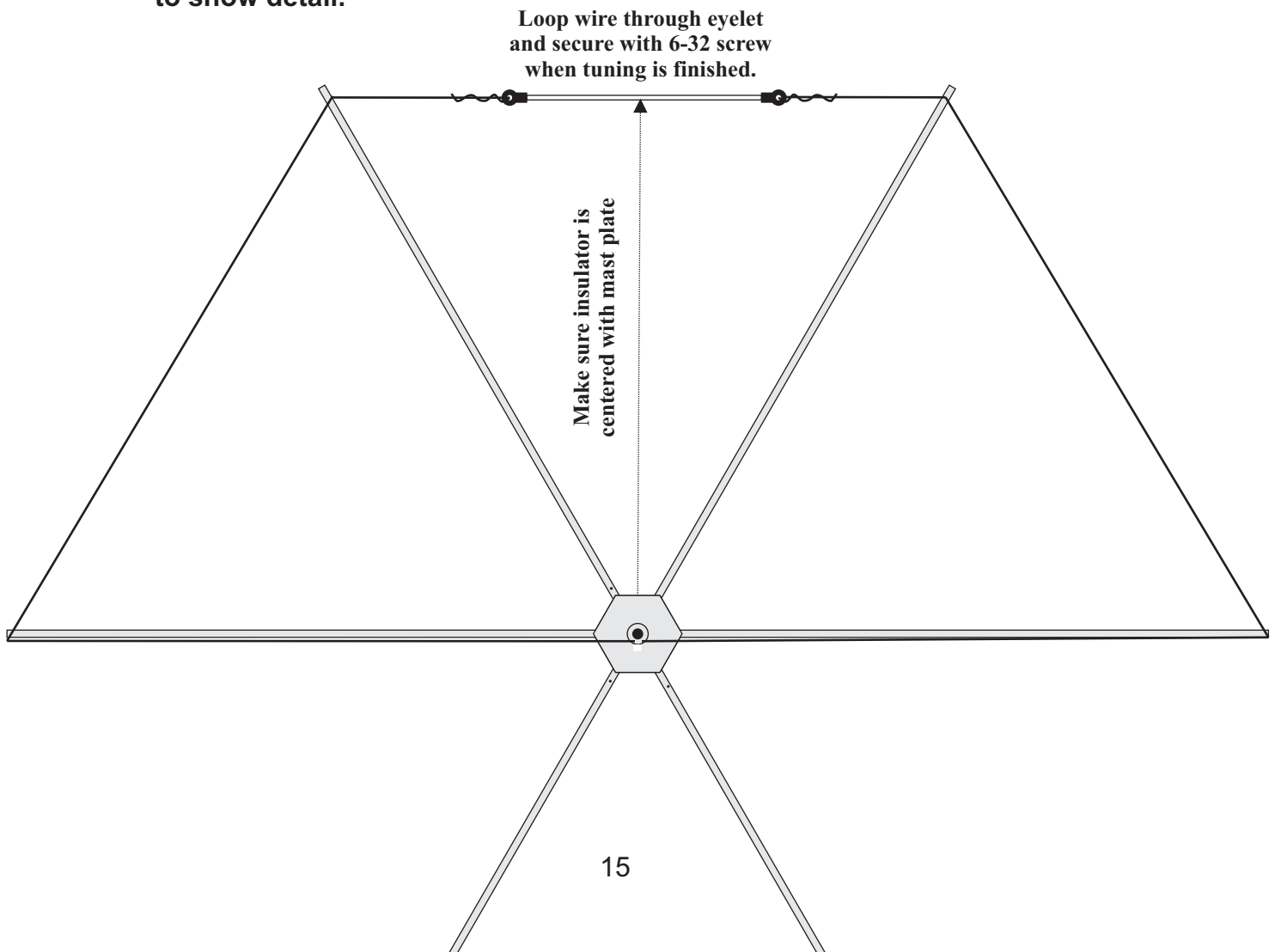

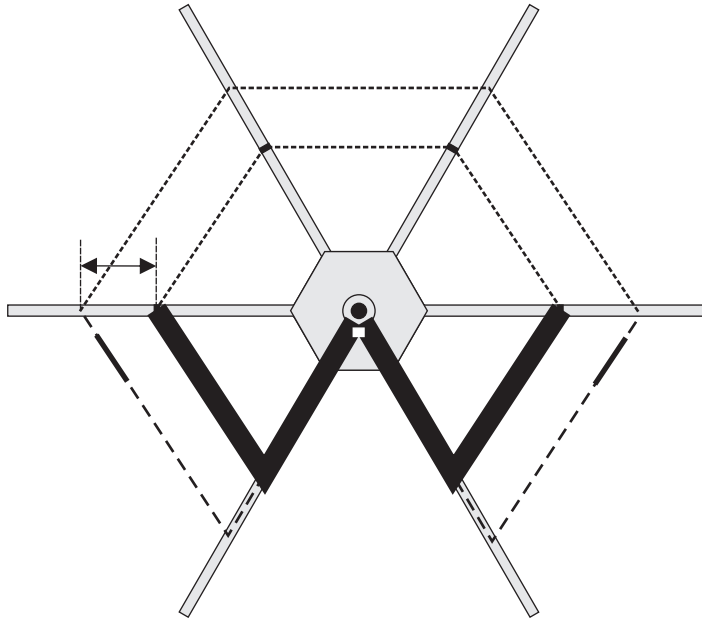

One of the things that will affect where the swr dip occurs is the placement of the wire guides. If the “W” of the driven elements has been flattened, it will cause the swr dip to move change as the electrical length of the wire has changed.



If you find in your application that the driven element needs to be longer, then you can add wire to the tips without moving the clamps. Hang a small amount of wire from the tip of the driven element on each side where the insulator attaches to it. Trim the wire until the frequency you desire is achieved. This is only needed if your swr dip is still too high in frequency when the antenna is finished.

Driven element (W)

Reflector element



Tune the antenna while it is at least 10 feet off the ground. Do not attempt to tune the antenna with it on the ground. A frequency shift will occur when the antenna is raised therefore it should be tuned as close to its final location as possible. The 20-40 meter bands will be most affected by the distance above ground.

The recommended support mast is at least a 1-1/2 diameter steel pipe with a length that will place the base of the antenna at a safe height above ground. It should not be in contact with trees, buildings or other objects. Never allow the element wires to contact anything. Arcing can occur and may cause a fire.

Although the antenna is designed to operate efficiently without the requirement of an earth ground, SAFETY GROUNDING must still be provided to protect you and your equipment from lightning and static discharges.

Extra ropes may be added if you desire to support the antenna in heavy ice or snow conditions. Use the large hose clamp at the top of the support mast and tie the rope around the smaller tube at the joints of the elements. Use a UV resistant rope (not supplied)

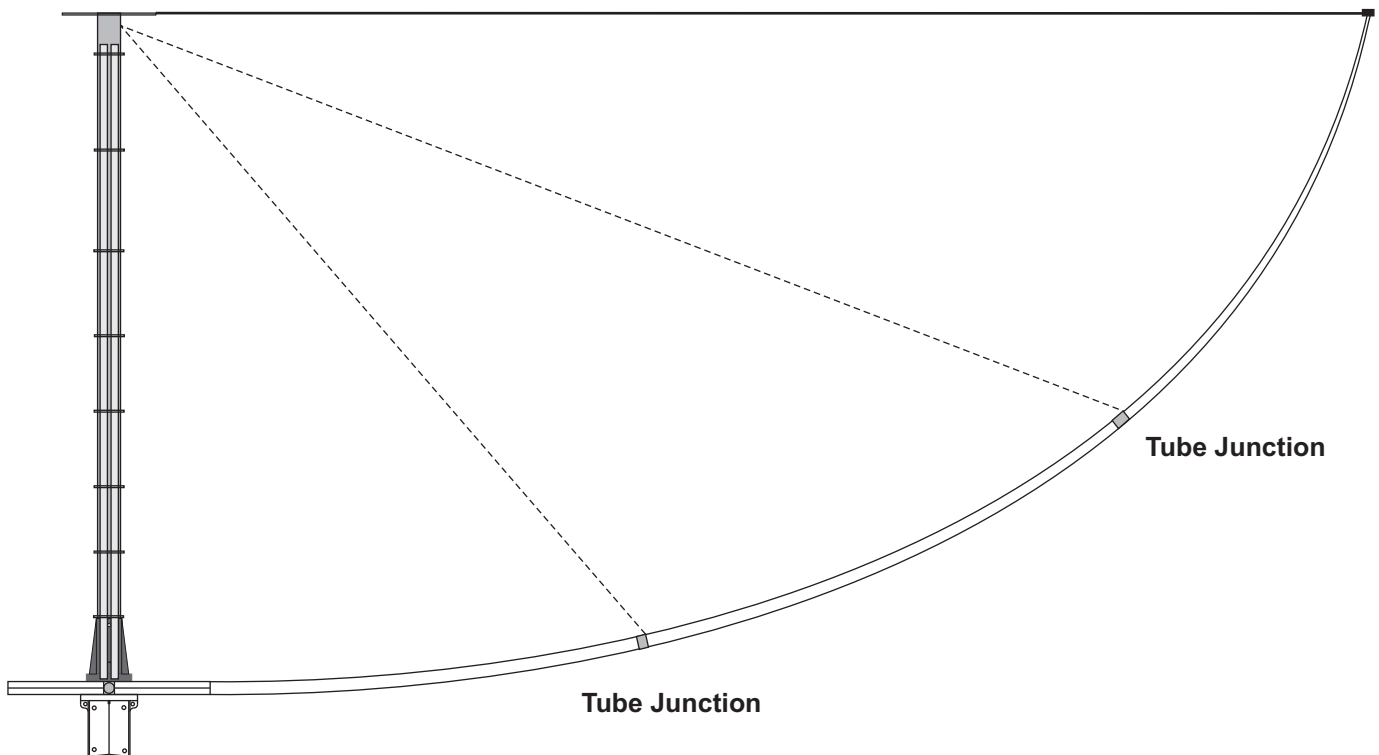

662-1000S	1/4-20 X 1 SS BOLT	qty 7
711-2537S-SL	1/4 SPLIT WASHER	qty 23
705-2520S	1/4-20 HEX NUT	qty 23
662-1500S	1/4-20 X 1-1/2 SS BOLT	qty 12
745-3106S	#6 HOSE CLAMP	qty 32
745-3110S	#10 HOSE CLAMP	qty 24
736-1845-FI	FEED TUBE INSULATOR	qty 8
736-1845-W	ABS WASHER	qty 5
705-2520S-NL	1/4-20 NYLON LOCKNUT	qty 3
662-3250S	5/16 X 3/4 SS	qty1
736-1845-RR	ROPE RING	qty 1
736-1845-FS	FEED TUBE SPACER	qty 3
656-0750S	6-32 X 3/4SS	qty 18
705-0632S-K	6-32 KEEP NUT	qty 64
656-0500S-A	#6 self taping screw	QTY 8
745-3116S	#16 HOSE CLAMP	qty 1
5038200	U-BOLT	qty 2
745-2149B	CABLE TIE BLACK	qty 40
745-1835-1	1/2 TUBE CLAMP W HOLE	qty 6
160110	SPACER	qty 6
014388	10-24 X 1	qty6
705-1024S-NL	10-24 NYLON LOCK	qty 6
736-1838	ABS WIRE BRACKET	qty 45
11-1848-SC	40 MTR SHUNT COIL	qty 1
662-3250S	1/4-20 X 3-3/4 BOLT	QTY 1
656-0312S	6-32 X 5/16SS	qty30

GENERAL INSTALLATION INSTRUCTIONS FOR MAST MOUNTED ANTENNAS

1. Assemble your new antenna on the ground at the installation site. Keep separate assembly instructions that come with it. Large CB and Amateur beams may have to be finally assembled on the tower or mast.
2. On the ground, clamp the antenna to mast and connect the coaxial cable to the antenna.
3. To insure that the mast does not fall the "wrong way" it should get away during the installation or takedown, durable non-conductive rope should be secured at each two foot level as the mast is raised. The boss stands in a position where he can yank or pull the ropes if the need arise to deflect the falling mast away from hazards (such as power lines) into a "safe fall" (such as a yard or driveway). The ropes are tied taut at the base of the mast after installation and in place at the various levels.
4. Install selected mounting bracket.
5. If you are going to use guy wire installation instead of a mounting bracket:
 - install guy anchor bolts
 - estimate length of guy wire and cut
 - attach a mast using guy ring
6. Carefully take antenna and mast assembly to mounting bracket and insert. Tighten camp bolts. In case of guyed installation, it will be necessary to have at least a second person hold the mast upright while the guy wires are attached and tightened to the anchor bolts.
7. Install self-adhering "DANGER" label packaged in antenna hardware kit at eye level on your mast.
8. Install ground rod to drain off static electricity build-up and connect ground wire to mast and ground rod. Use special ground rods, not a spare piece of pipe.

EXAMPLE OF ANTENNA GROUNDING AS PER NATIONAL ELECTRICAL CODE INSTRUCTIONS

1. Use No. 10 AWG copper or No. 8 AWG or larger copper-clad steel or bronze wire, as ground wires for both mast and lead-in. Securely clamp the wire to the bottom of the mast.
2. Secure lead-in wire from antenna to antenna discharge unit and mast ground wire to house with stand-off insulators spaced from 4 feet (1.2 meters) to 6 feet (1.8 meters) apart.
3. Mount antenna discharge unit as close as possible to where the lead-in wire enters the house.
4. Drill a hole in wall (CAREFUL! There are wires in that wall.) near your set just large enough to permit entry of cable.
5. Push cable through hole and form a rain drip loop close to where it enters the house.
6. Put small amount of caulking around cable where it enters house to keep out drafts.
7. Install static electricity discharge unit.
8. Connect antenna cable to the set.

You should not attempt to raise a mast in excess of 30 feet in height/length (not including the antenna proper) in a fully-extended condition. Thirty to fifty foot tubular masts must be elevated, a section at a time, with the base or outer section secured in place with guy wires. GET PROFESSIONAL HELP.

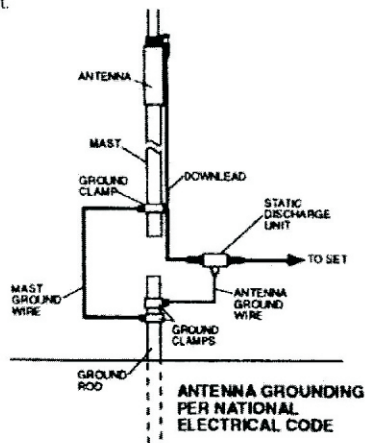

WARNING

INSTALLATION OF THIS PRODUCT NEAR POWER LINES IS DANGEROUS. FOR YOUR SAFETY, FOLLOW THE ENCLOSED INSTALLATION DIRECTIONS.

HOW TO INSTALL YOUR OUTDOOR ANTENNA SAFELY IN ACCORDANCE WITH THE RECOMMENDATIONS OF THE U.S. CONSUMER PRODUCT SAFETY COMMISSION

YOU, YOUR ANTENNA, AND SAFETY

Each year hundreds of people are killed, mutilated or receive severe permanent injuries when attempting to install an antenna. In many of these cases, the victim was aware of the danger of electrocution, but did not take adequate steps to avoid the hazard.

For your safety, and to help you achieve a good installation, please **READ** and **FOLLOW** the safety precautions below. **THEY MAY SAVE YOUR LIFE!**

1. If you are installing an antenna for the first time, please, for your own safety as well as others, seek **PROFESSIONAL ASSISTANCE**. Consult your dealer. He can explain which mounting method to use for the size and type antenna you are about to install.
2. Select your installation site with **safety**, as well as performance, in mind. (Detailed information on Site Selection appears in a separate section of this booklet.) **REMEMBER: ELECTRIC POWER LINES AND PHONE LINES LOOK ALIKE. FOR YOUR SAFETY, ASSUME THAT ANY OVERHEAD LINES CAN KILL YOU.**
3. Call your electric power company. Tell them your plans and ask them to come look at your proposed installation. This is a small inconvenience considering **YOUR LIFE IS AT STAKE**.
4. Plan your installation procedure carefully and completely **before** you begin. Successful raising of a mast or tower is largely a matter of coordination. Each person should be assigned to a specific task, and should know what to do **and** when to do it. One person should be designated as the "boss" of the operation to call out instructions and watch for signs of trouble.
5. When installing your antenna, **REMEMBER: DO NOT** use a metal ladder. **DO NOT** work on a wet or windy day. **DO** dress properly -shoes with rubber soles and heels, rubber gloves, long sleeve shirt or jacket.
6. If the assembly starts to drop, get away from it and let it fall. Remember, the antenna, mast, cable and metal guy wires are all excellent conductors of electrical current. Even the slightest touch of any of these parts to a power line complete an electrical path through the antenna and the **installer-THAT'S YOU!**
7. If any part of the antenna system should come in contact with a power line-**DON'T TOUCH IT OR TRY TO REMOVE IT YOUR SELF. CALL YOUR LOCAL POWER COMPANY.** They will remove it safely.

If an accident should occur with the power lines call for qualified emergency help immediately.

FULL 12-MONTH WARRANTY

MFJ Enterprises, Inc. warrants to the original owner of this product, if manufactured by MFJ Enterprises, Inc. and purchased from an authorized dealer or directly from MFJ Enterprises, Inc. to be free from defects in material and workmanship for a period of 12 months from date of purchase provided the following terms of this warranty are satisfied.

1. The purchaser must retain the dated proof-of-purchase (bill of sale, canceled check, credit card or money order receipt, etc.) describing the product to establish the validity of the warranty claim and submit the original or machine reproduction of such proof of purchase to MFJ Enterprises, Inc. at the time of warranty service. MFJ Enterprises, Inc. shall have the discretion to deny warranty without dated proof-of-purchase. Any evidence of alteration, erasure, or forgery shall be cause to void any and all warranty terms immediately.
2. MFJ Enterprises, Inc. agrees to repair or replace at MFJ's option without charge to the original owner any defective product provided the product is returned postage prepaid to MFJ Enterprises, Inc. with a personal check, cashiers check, or money order. This is good on all products except antennas and software to cover postage and handling for return from in warranty service. We also take MasterCard, Visa, American Express, and Discover credit cards. Postage and handling may vary according to the weight of the product in question. You should specify what type of delivery service you wish. We can send by UPS, U.S. Postal service or Fedex. MFJ doesn't guarantee delivery by US Postal Service.
3. MFJ Enterprises, Inc. will supply replacement parts free of charge for any MFJ product under warranty upon request, provided the following terms are satisfied. MFJ must receive the original parts you wish to replace, your proof-of-purchase, and a personal check, cashiers check or money order must be provided to cover postage and handling. Postage and handling may vary according to the weight of the product in question. We also take MasterCard, Visa, American Express and Discover credit cards.
4. This warranty is **NOT** void for owners who attempt to repair defective units. Technical consultation is available by calling (662) 323-5869
5. This warranty does not apply to kits sold by or manufactured by MFJ Enterprises, Inc.
6. Wired and tested PC board products are covered by this warranty provided **only the wired and tested PC board product is returned**. Wired and tested PC boards installed in the owner's cabinet or connected to switches, jacks, or cables, etc. sent to MFJ Enterprises, Inc. will be returned at the owner's expense un-repaired.
7. Under no circumstances is MFJ Enterprises, Inc. liable for consequential damages to person or property by the use of any MFJ products.
8. **Out-of-Warranty Service:** MFJ Enterprises, Inc. will repair any out-of-warranty product provided the unit is shipped prepaid. All repaired units will be shipped COD to the owner. Repair charges will be added to the COD fee unless other arrangements are made.
9. This warranty is given in lieu of any other warranty expressed or implied.
10. MFJ Enterprises, Inc. reserves the right to make changes or improvements in design or manufacture without incurring any obligation to install such changes upon any of the products previously manufactured.
11. All MFJ products to be serviced in-warranty or out-of-warranty should be addressed to **MFJ Enterprises, Inc., 300 Industrial Park Rd, Stakville, Mississippi 39759, USA** and must be accompanied by a letter describing the problem in detail along with a copy of your dated proof-of-purchase and a telephone number.
12. This warranty gives you specific rights, and you may also have other rights, which vary from state to state.