

This 1980's HB35T antenna instructions manual has been very hard to recover. So I am happy to share it to the hams from the courtesy of WA6IPD Herbert Art RIDEOUT.

Art was owner of this antenna from 1981 to 2001 and had kept a copy of the manual.

So we are in luck ! And I could install the one I bought second hand in 2005.

"I have had my TET HB35T up for 20 years without any problems. It is a solidly built antenna and went up easy. I have always felt that the performance of the TET was comparable to the 3 element Quad. I did have to add a cable from front to rear of the 8.0m boom for support otherwise it did tend to droop. A very nice antenna, if you can find one in good shape buy it you will not be disappointed." WA6IPD.

F6GOX Laurent BEUGNET, 2013.

## TET ANTENNA SYSTEMS

HB35T

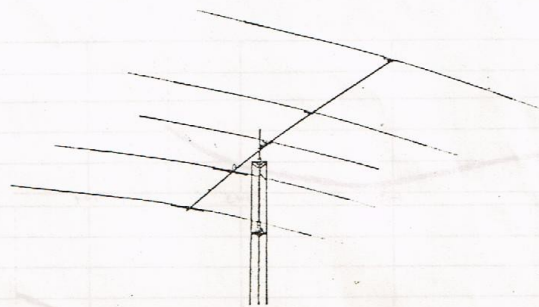

HB35T
14/21/28Mhz
4/5
10/13/12.5dB
23dB
1.5
3KWweap
50ohm
8.4m
8.0m
22.5kg

**TANIGUCHI ENGINEERING TRADERS**  
2589-1, SHIMONAGAYA-CHO, KOHNAN-KU, YOKOHAMA 233 ☎ 045-823-6429  
**TET U.S.A** ☎ 405-360-6410  
425 HIGHLAND PARKWAY, NORMAN, OKLAHOMA 73069  
1309 SIMPSON WAY, SUITE F ESCONDIDO, CALIFORNIA 92025  
**TET ANTENNA SYSTEMS PHILIPPINES**  
406 RIZAL AVENUE EXTENSION, CALOOCAN CITY, PHILIPPINES

SPECIFICATIONS

MODEL HB35T

BANDS		14/21/28 MHz
NUMBER OF ELEMENTS		5
ELEMENTS PER BAND	10/15M	5
	20M	4
ANTENNA GAIN (dBd)	10M	12
	15M	13
	20M	10
FRONT TO BACK RATIO (dB)		23
VSWR		1.5:1 or better
POWER CAPABILITY		3KW PEP
NOMINAL FEED IMPEDANCE		50 OHM
MAXIMUM ELEMENT LENGTH		27' 6"
BOOM LENGTH		24' 7"
TURNING RADIUS		18' 10"
SUITABLE MAST SIZE		1½-2"
WEIGHT		49.5 Lbs
WIND SURFACE AREA		6.1 Square Feet
WIND LOAD AT 80 MPH		162 Lbs

VSWR VS FREQUENCY (TYPICAL)

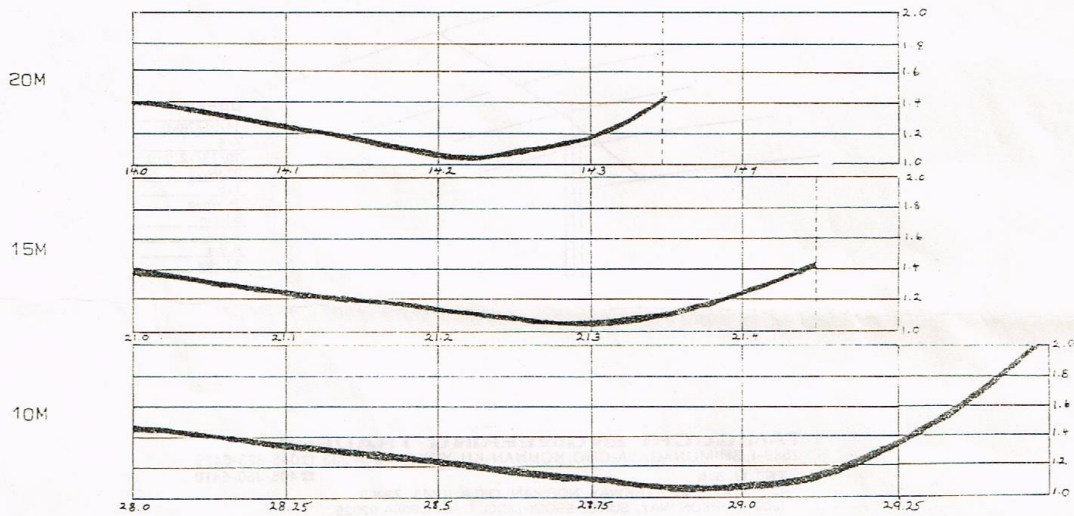

## 1.0 INTRODUCTION

1.1 This antenna is a high performance triband beam antenna designed to provide wideband operation on the 20,15 and 10 meter amateur band.

1.2 The antenna consists of two driven elements (Radiator Ra, and Reflector Ref) and parasitic Directors.

1.3 Each band is tuned by Hi-Q trapped elements, resulting in high radiation efficiency, maximum power handling capability, and low VSWR over a wide bandwidth.

## 2.0 ASSEMBLY OF THE HB 35T ANTENNA

2.1 To obtain maximum performance, the instructions and measurements for assembly must be followed as closely as possible.

2.2 Select a clean level area large enough to accommodate the full antenna span.

### 2.3 Tools Required:

- A. #2 Phillips screwdriver
- B. 10mm and 13mm metric sockets or open end wrenches
- C. Measuring tape, 12 foot or metric 3 or 4 meters long
- D. Felt tip marking pen

## 3.0 BOOM ASSEMBLY

3.1 The boom consists of four sections of 50mm tubing, (3 sections 2000mm, 1 section 1500mm long) and three internal sleeves 300mm long by 46mm dia.

3.2 Insert the sleeve into the end of one boom section. Align the drilled holes and secure with 4x10mm self tapping screws and lockwashers. In a similar manner, continue assembling the remaining boom sections. The completed boom is 7500mm long with a cap on each end. Fig. 3.

3.3 Refer to Figure 2. Using a felt tipped pen, place marks on the boom where the clamps holding the various elements are to be attached. Measurements are made beginning 30mm from the inside edge of one boom end cap.

## 4.0 ASSEMBLY OF ELEMENTS

4.1 Identify parts for five elements. All are identified as D3, D2, D1, Ra or Ref. Refer to Figure 2 and Table 1 for element length.

4.2 Refer to Figure 1 and 2 for assembly detail.

4.3 Two sections of 15mm aluminum square stock 800mm long are used for each driven element clamp assembly. (Ra and Ref) Four BR22 insulating brackets are mounted to the square stock with 32UM U Bolts, M6 washers and nuts.

Two 60US U Bolts are installed at the center of each bracket from the underside. The finished bracket will consist of two sections of square stock, 4 element support clamps, and 2 element to boom U Bolts.

In a similar manner assemble the D2<sup>D3</sup> and D1 element bracket using the 200mm long square stock and two BR22 insulating brackets.



4.4 Insert main element Ra sections through the plastic spacers of large boom to element brackets. To accomplish this, loosen or remove the spacers from the brackets and insert the element through the spacers. Do not tighten bracket hardware at this time.

4.5 Join the main element and sub element by inserting the sub element into the main element. Secure with 4x10mm self tapping screws and lockwashers. Verify element lengths against Table 1.

4.6 Insert the Aux. element into the longest end of trapped coils. Align the drilled holes and secure with self tapping hardware. Now insert the trap short end first into the sub element. Secure with self tapping hardware.

4.7 Repeat steps 4.4 through 4.6 for element Ref.

4.8 Insert the sleeve (19x200mm) into the end of main element section D-1 and align the drilled holes and secure with 4x10mm self tapping screws and lockwashers.

4.9 Slide the small boom to element bracket over the main element and position the bracket in the center of the sleeve section.

4.10 Assemble the remaining D1 element sections according to step 4.5 and 4.6.

4.11 Position all elements on their brackets so that the drain holes on the trap assemblies are facing downward.

4.12 Repeat steps 4.8 through 4.11 for element D2.

#### 5.0 ELEMENT INSTALLATION

5.1 Attach elements D3, D2, D1, Ra, and Ref to the boom in the positions previously marked in step 3.3. Each element is secured with two U Bolts, washers and nuts. Before tightening the assembly to the boom, slide in aluminum block between the boom and the bracket. Refer to Figure 1.

5.2 The phasing line consists of four sections of 9mm tubing 996mm long and plastic plate and crossing bars.

5.3 Attach the four sections of phase line tubing to the plastic plate with two 7x50mm insulating spacers and two crossing bars. (Refer to Fig.6)

Insert 4x20mm screws through the tubing and spacers, pass the end of the screws through the plastic plate and secure with M4 nuts and washers.

The completed assembly will have two parallel runs of 9mm tubing spaced 20mm apart mounted to the same side of the plastic plate with the insulating spacers inside the tubing for mechanical support.

This assembly provides an electrical crossover and should be checked for shorts.

5.4 Mount the phasing line to elements Ref and Ra. This line is secured to the 9mm tubing extending from the center of

each main Ra and Ref element with 4x25mm screw washers and nuts. Note that the short insulated spacer is installed in the 9mm tubing between the main element halves. Check position of all hardware as shown in Figure 5. Element Ra must be positioned so that no strain is placed on the phasing line.

5.5 Attach the terminals of the Balun to element RA under the screws just installed in step 5.4

5.6 Tighten all bracket hardware, being careful to observe element alignment.

#### 6.0 BOOM TO MAST BRACKET INSTALLATION

6.1 Refer to Figure 4 for assembly detail. Use four U Bolts (60U) to attach the bracket to the boom. Position the bracket at the balance point of the antenna, approximately midway between elements Ra and D1. Use large block between the boom and mast mounting plate.

6-2 Use two U Bolts with large aluminium block when securing the antenna to your mast.

6.3 This completes assembly of your TET HB35T triband beam.

TABLE 1

H935T

	METRIC			
	M	S	T	A
D3	1950mm	370mm	695mm	450mm
D2	1950mm	400mm	695mm	450mm
D1	1950mm	475mm	330mm	-
RA	1950mm	650mm	690mm	520mm
REF	1950mm	950mm	675mm	570mm

	INCHES			
	M	S	T	A
D3	76 3/4"	14 1/2"	27 1/8"	17 3/4"
D2	76 3/4"	15 3/4"	27 1/8"	17 3/4"
D1	76 3/4"	18 3/4"	13"	-
RA	76 3/4"	25 5/8"	27 1/8"	20 1/2"
REF	76 3/4"	37 3/8"	26 9/16"	22 1/2"

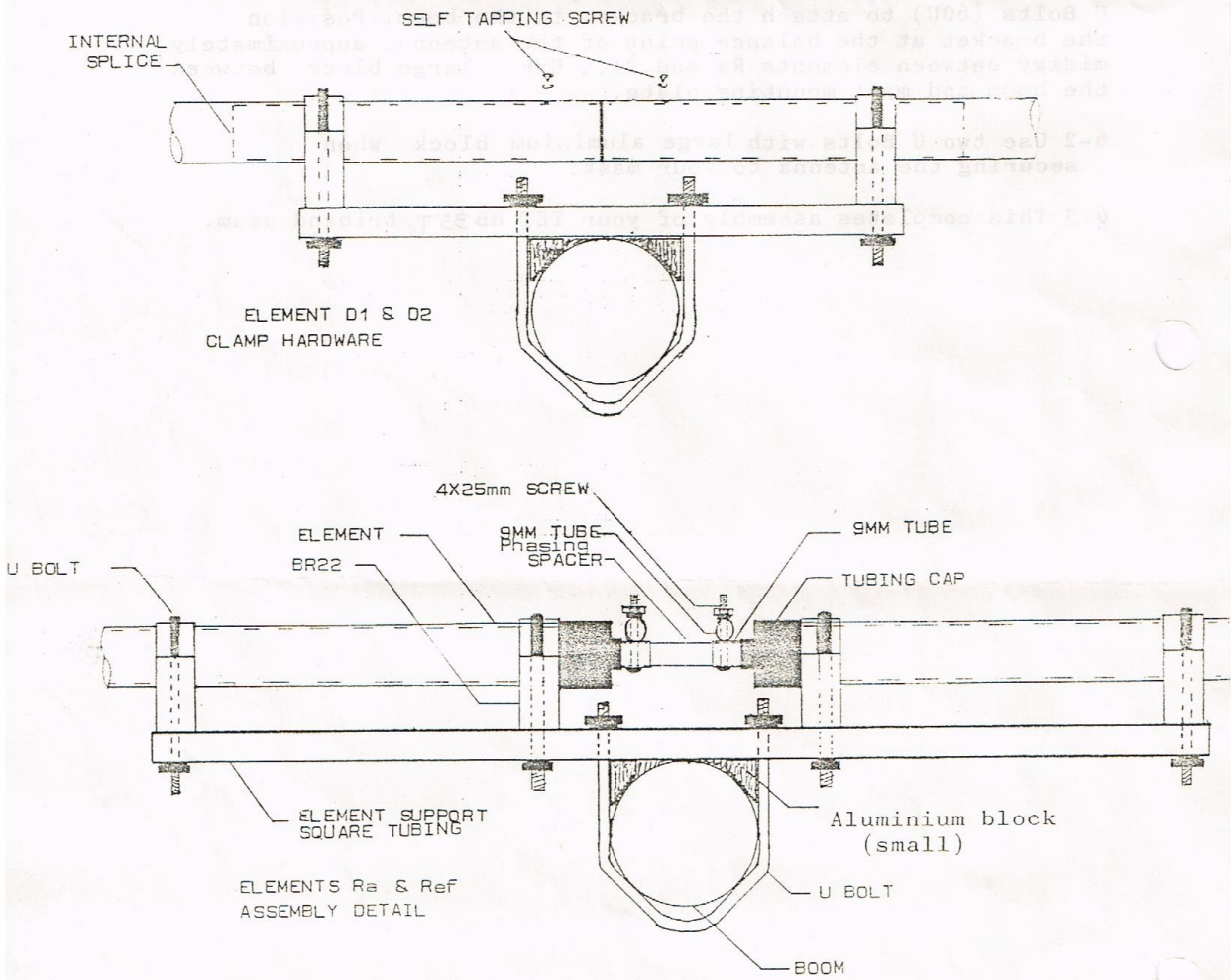

FIGURE 1



ASSEMBLY INSTRUCTIONS

MODEL HB35T

D3

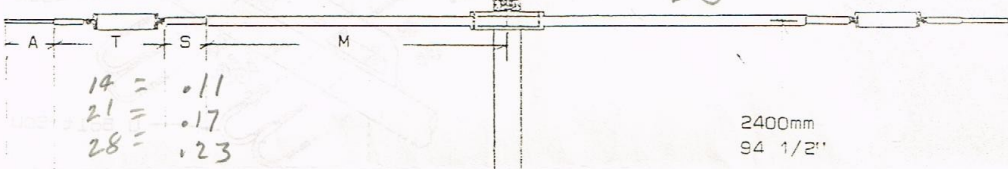

D2

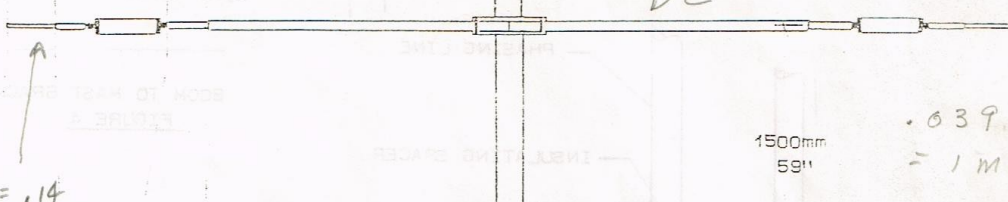

D1

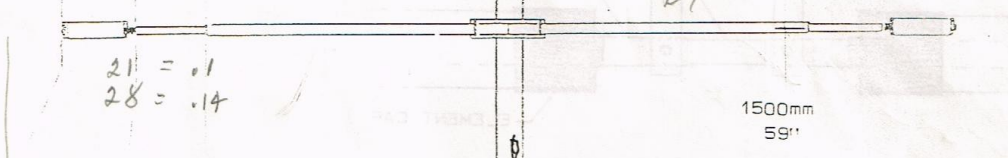

RA

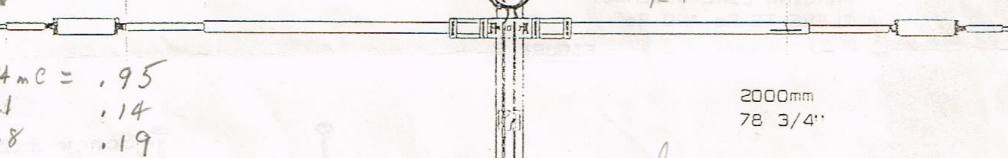

Ref



14 = 14.263  
 21 = 21.338  
 28 = 28.650

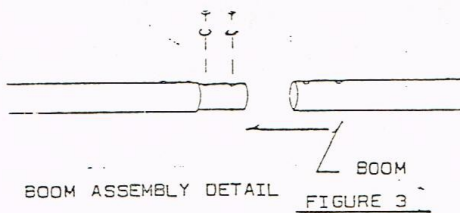
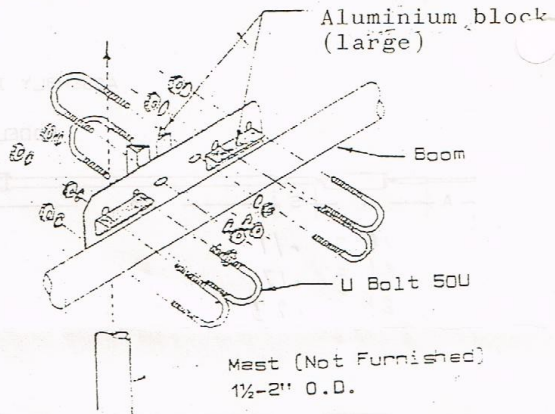
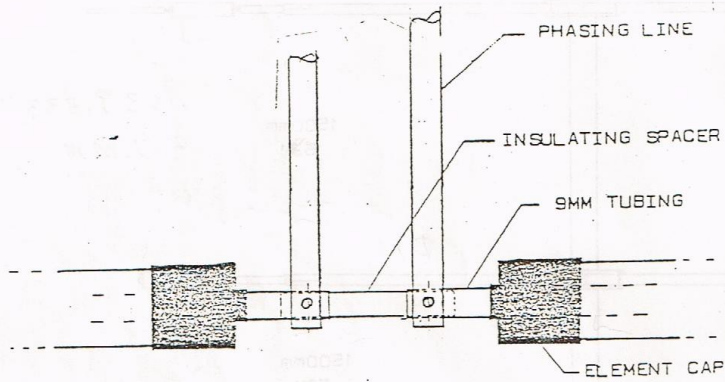

FIGURE 3



BOOM TO MAST BRACKET  
FIGURE 4



PHASING LINE ASSEMBLY  
ELEMENTS Ra AND Ref

FIGURE 5

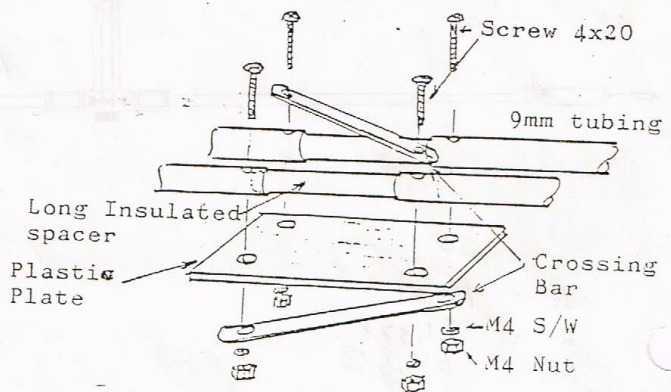

Figure 6 Circuit Board  
Detail



