

# TET<sup>®</sup>

VANTENNA SYSTEMS

## INSTRUCTIONS

HB - 43 sp

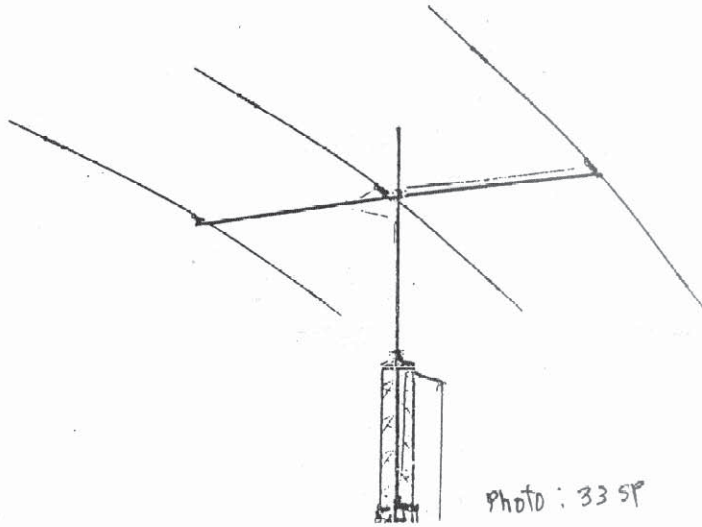

**TANIGUCHI ENGINEERING TRADERS**  
2565-1, SHIMONAGAYA-CHO, KOHNAN-KU, YOKOHAMA 233  
TET U.S.A. : 425 HIGHLAND PARKWAY, NORMAN, OKLAHOMA 73069

## 1.0 INTRODUCTION

1.1 This antenna is a high performance triband beam antenna designed to provide wideband operation on the 20,15 and 10 meter amateur band.

1.2 The antenna consists of two driven elements (Radiator Ra, and Reflector Ref) and parasitic Directors.

1.3 Each band is tuned by Hi-Q trapped elements, resulting in high radiation efficiency, maximum power handling capability, and low VSWR over a wide bandwidth.

## 2.0 ASSEMBLY OF THE HB43SP ANTENNA

2.1 To obtain maximum performance, the instructions and measurements for assembly must be followed as closely as possible.

2.2 Select a clean level area large enough to accommodate the full antenna span.

2.3 Tools Required:

- A. #2 Phillips screwdriver
- B. 10mm and 13mm metric sockets or open end wrenches
- C. Measuring tape, 12 foot or metric 3 or 4 meters long
- D. Felt tip marking pen

## 3.0 BOOM ASSEMBLY

3.1 Lay out the parts for the boom. The boom consists of three sections 2000mm long tubing and two sleeves .

3.2 Insert the sleeve into the end of one boom section. Align the drilled holes and secure with 4x10mm self tapping screws and lockwashers. In a similar manner, continue assembling the remaining boom sections. The completed boom is 6000mm long with a cap on each end. Fig. 3.

3.3 Refer to Figure 2 Using a felt tipped pen, place marks on the boom where the clamps holding the various elements are to be attached. Measurements are made beginning 30mm from the inside edge of one boom end cap.

## 4.0 ASSEMBLY OF ELEMENTS

4.1 Identify parts for four elements. All are identified as D2, D1, Ra or Ref. Refer to Figure 2 and Table 1 for element length.

4.2 Refer to Figure 1 and 2 for assembly detail.

4.3 Two sections of 15mm aluminum square stock 800mm long are used for each driven element clamp assembly. (Ra and Ref) Four BR22 insulating brackets are mounted to the square stock with 32UM U Bolts, M6 washers and nuts.

Two 60US U Bolts are installed at the center of each bracket from the underside. The finished bracket will consist of two sections of square stock, 4 element support clamps, and 2 element to boom U Bolts.

In a similar manner assemble the D2 and D1 element bracket using the 200mm long square stock and two BR22 insulating brackets.

4.4 Insert main element Ra sections through the plastic spacers of large boom to element brackets. To accomplish this, loosen or remove the spacers from the brackets and insert the element through the spacers.

Do not tighten bracket hardware at this time.

4.5 Join the main element and sub element by inserting the sub element into the main element. Secure with 4x10mm self tapping screws and lockwashers. Verify element lengths against Table 1

4.6 Insert the Aux. element into the longest end of trapped coils. Align the drilled holes and secure with self tapping hardware. Now insert the trap short end first into the sub element. Secure with self tapping hardware.

4.7 Repeat steps 4.4 through 4.6 for element Ref.

4.8 Insert the sleeve (19x200mm) into the end of main element section D-1 and align the drilled holes and secure with 4x10mm self tapping screws and lockwashers.

4.9 Slide the small boom to element bracket over the main element and position the bracket in the center of the sleeve section.

4.10 Assemble the remaining D1 element sections according to step 4.5 and 4.6.

4.11 Position all elements on their brackets so that the drain holes on the trap assemblies are facing downward.

4.12 Repeat steps 4.8 through 4.11 for element D2.

## 5.0 ELEMENT INSTALLATION

5.1 Attach elements D2 D1, Ra, and Ref to the boom in the positions previously marked in step 3.3. Each element is secured with two U Bolts, washers and nuts. Before tightening the assembly to the boom, slide in two short black wedge blocks between the boom and the bracket. Refer to Figure 1

5.2 The phasing line consists of 4 sections of 9mm tubing 995mm long with a printed circuit board mounted in the center of the line. Handle this assembly with care so as not to damage the circuit board during construction.

5.3 Attach the four (4) sections of phase line tubing to the printed circuit board along with the two long white insulated spacers. Insert 4x15mm screws through the tubing with the spacers inserted approximately 15mm inside the tubing. Pass the end of the screws through the circuit board and secure with M4 nuts.

The completed assembly will have two parallel runs of 9mm tubing spaced 20mm apart mounted to the same side of the circuit board with the insulated spacers inside the tubing for mechanical support. Check this assembly for shorts.

5.4 Mount the phasing line to elements Ref and Ra. This line is secured to the 9mm tubing extending from the center of

each main Ra and Ref element with 4x25mm screw washers and nuts. Note that the short insulated spacer is installed in the 9mm tubing between the main element halves. Check position of all hardware as shown in Figure 5. Element Ra must be positioned so that no strain is placed on the phasing line.

5.5 Attach the terminals of the Balun to element RA under the screws just installed in step 5.4

5.6 Tighten all bracket hardware, being careful to observe element alignment.

#### 6.0 BOOM TO MAST BRACKET INSTALLATION

6.1 Refer to Figure for assembly detail. Use four U Bolts (60U) to attach the bracket to the boom. Position the bracket at the balance point of the antenna, approximately midway between elements Ra and D1. Use 4 large blocks between the boom and mast mounting plate.

6-2 Use two U Bolts with two wedge black blocks when securing the antenna to your mast.

6.3 This completes assembly of your TET HB43SP triband beam.

TABLE #1

ELEMENT LENGTH (mm)	ELEMENT LENGTH (mm)			
	M	S	T	A
D2	1950	350	690	400
D1	1950	450	690	420
Ra	1950	675	690	570
Ref	1950	950	675	580

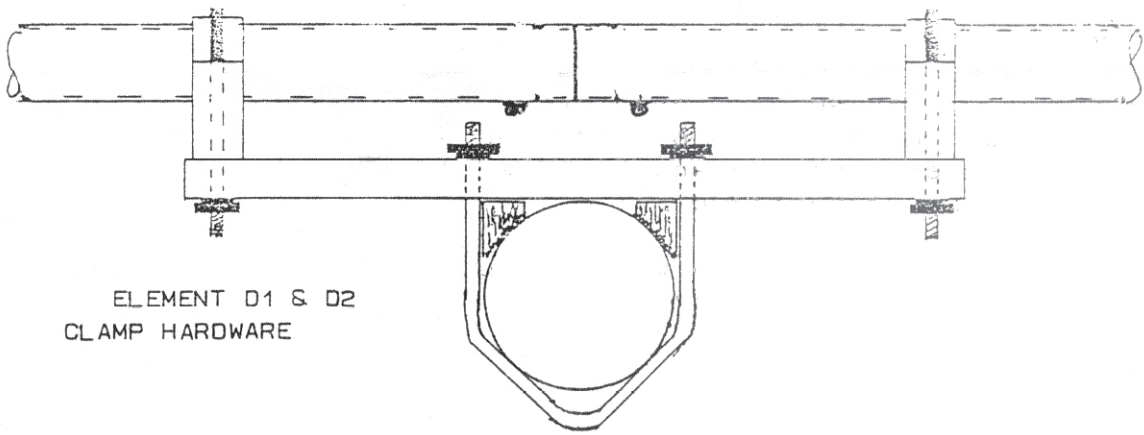

ELEMENT D1 & D2  
CLAMP HARDWARE

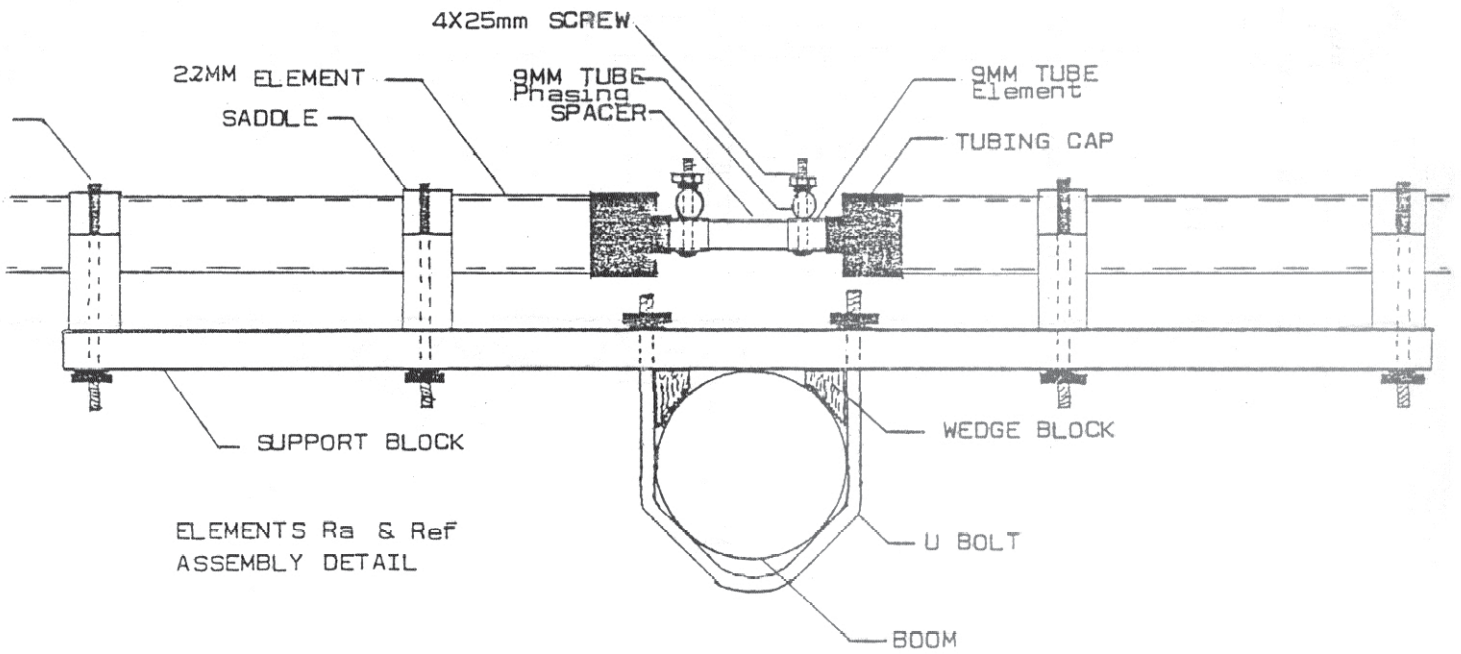

ELEMENTS Ra & Ref  
ASSEMBLY DETAIL

FIGURE 1

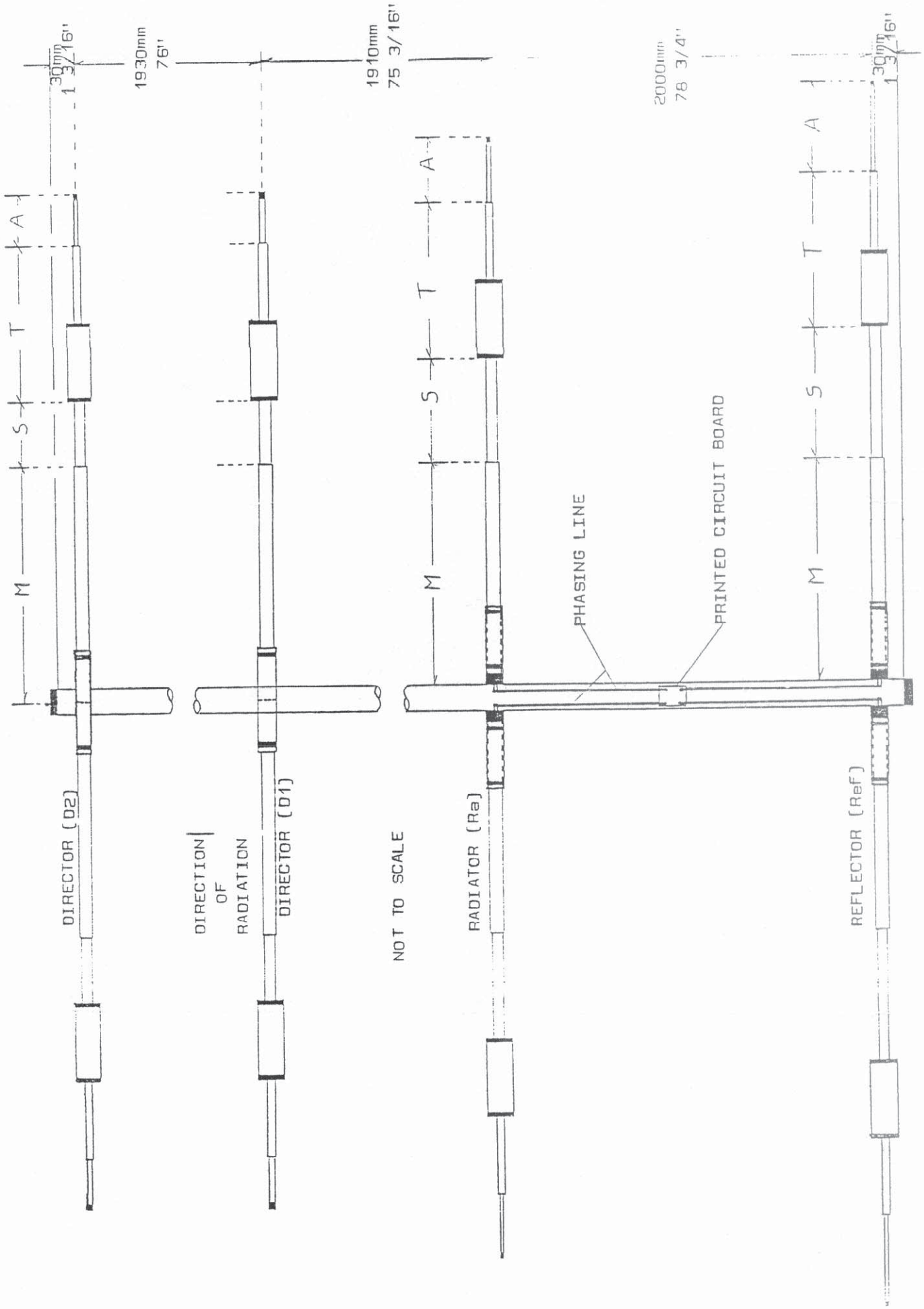
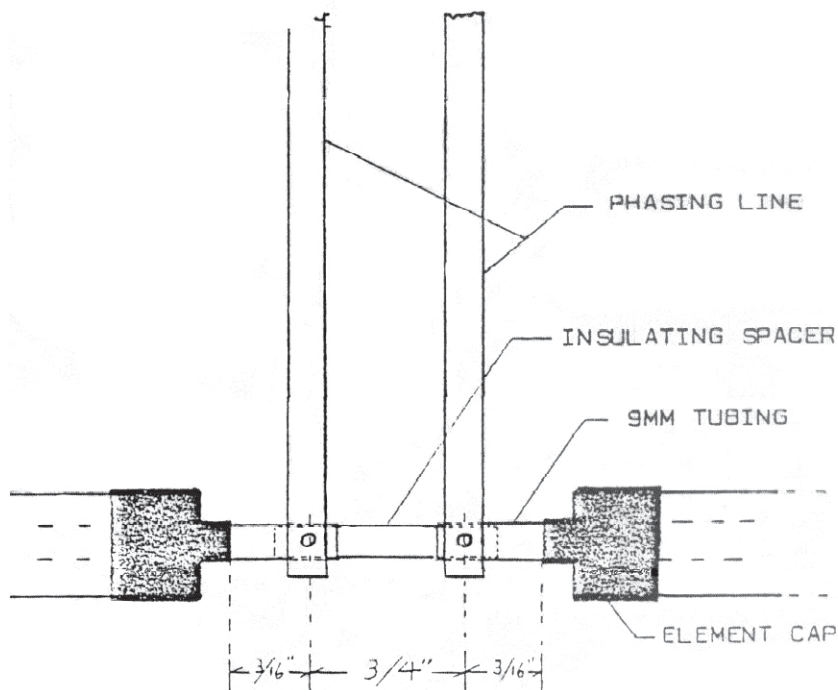
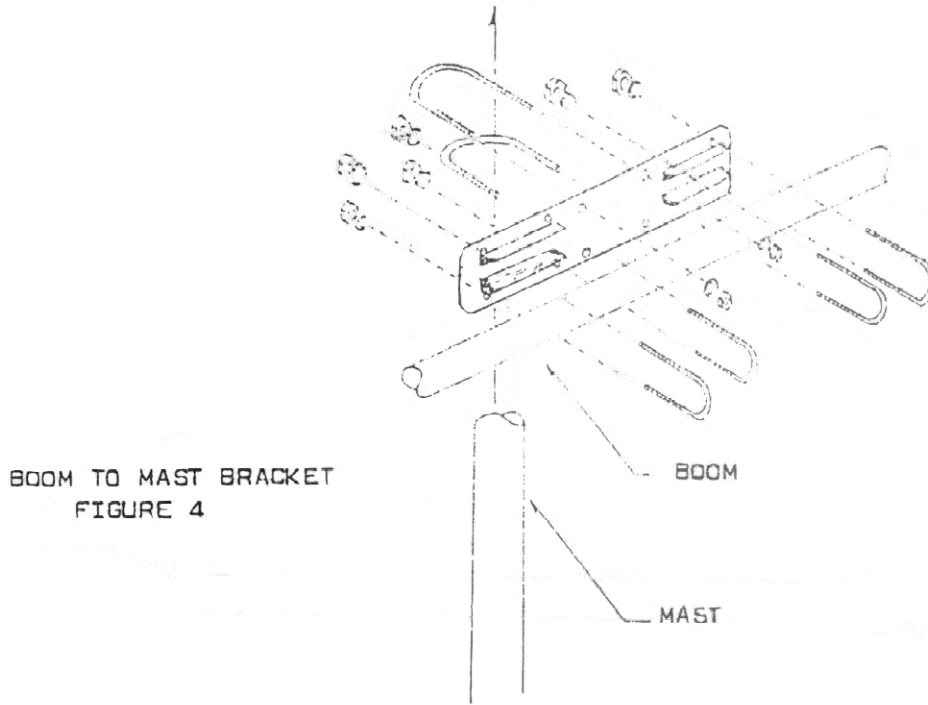
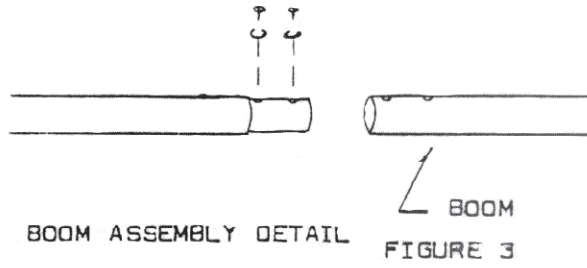
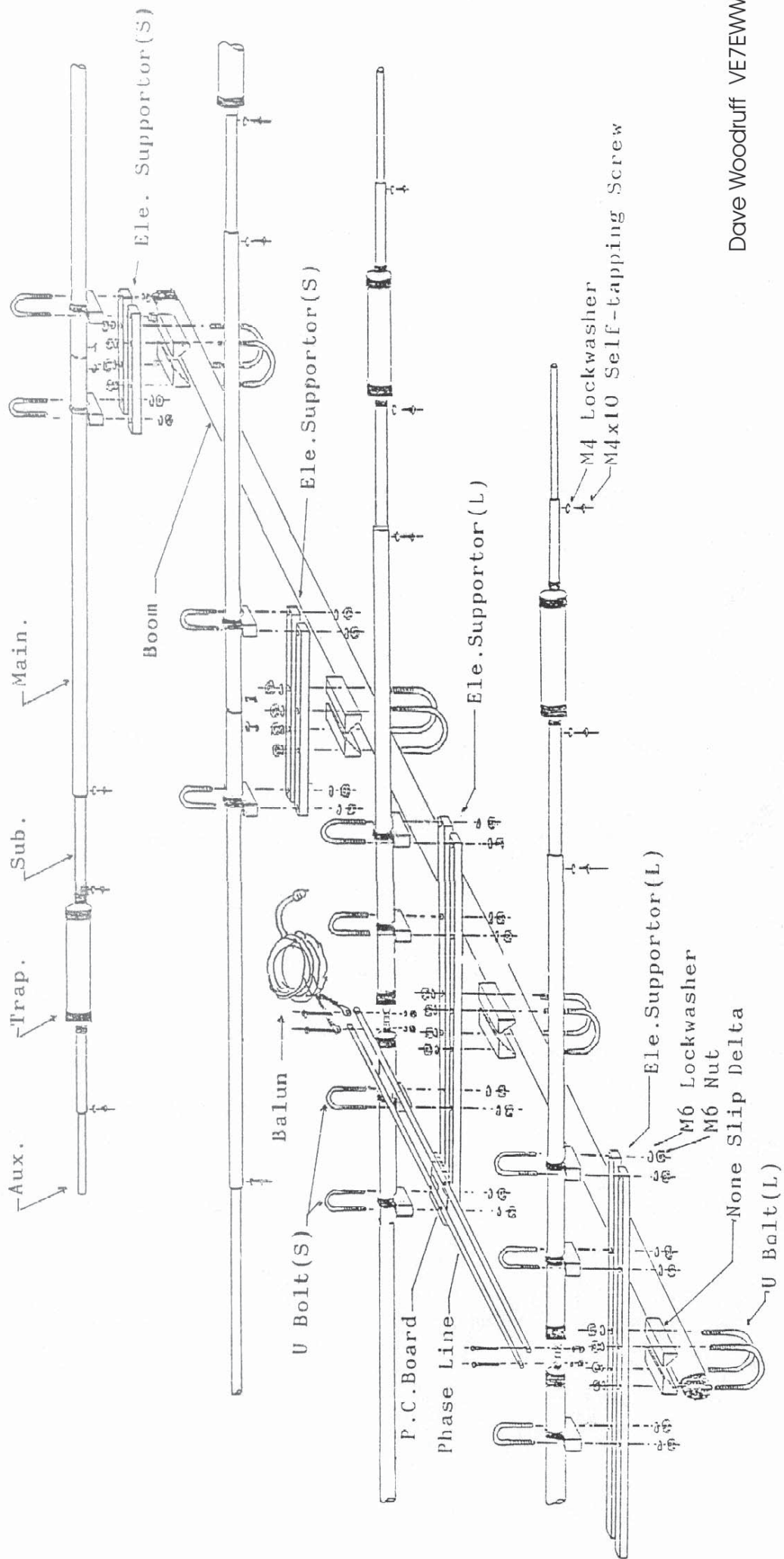

FIGURE 2



PHASING LINE ASSEMBLY  
ELEMENTS Ra AND Ref

FIGURE 5



Dave Woodruff VE7EWW