

The antenna AD-14-CQ/C is a 4-elements "cubical quad" antenna intended for use by radioamateurs on the 14, 21 and 28 MHz frequency range. The antenna is designed as "spider quad" or "diamond shaped" with inclined supporting elements thus enable optimum positions between reflector, radiator and directors. Supporting elements are made of fiberglass tubes ensuring good mechanical and climatic properties and on the other hand good isolation properties do not spoil electrical characteristics of the antenna.

The antenna has all wire elements prepared for immediate installation without any additional tuning. For coax. cable connection there are a special junction box, so called "dipole junction" with UHF female connector. Therefore the antenna and the cables are well protected against all weather conditions. The supporting boom is divided in two parts connected together with aluminum tube with mounting consoles enable to mount the antenna on the antenna rotator. Such construction enables easier antenna mounting or even use as "square shaped" antenna with 45° linear polarization saving us some space under the antenna. An "add-on" wire kit for WARC bands is available on request.



TECHNICAL DATA	
Frequency range	14, 21, 28 MHz
Impedance	50 ohm
VSWR	< 2 (DIAG. 1)
Gain	8.5 dBd (14 MHz) 10 dBd (21, 28 MHz)
Front-to-back ratio	15-25 dB
Front-to-side ratio	> 45 dB
Polarization	HOR/45°/VERT
Maximum power	1 kW CW, 2 kW PEP
Mass of antenna	30 kg
Supporting elem. length	4.0 m
Boom length	2 x 2.1 m
Diameter of rotation	10 m
Wind area (CxA)	0.45 m ²
Wind velocity	150 km/h

The antenna AD-14-CQ/C is a 4-elements "cubical quad" antenna intended for use by radioamateurs on the 14, 21 and 28 MHz frequency range. The antenna is designed as "spider quad" or "diamond shaped" with inclined supporting elements thus enable optimum positions between reflector, radiator and directors. Supporting elements are made of fibreglass tubes ensuring good mechanical and climatic properties and on the other hand good isolation properties do not spoil electrical characteristics of the antenna.

The antenna has all wire elements prepared for immediate installation without any additional tuning. For coax. cable connection there are a special junction box, so called "dipole junction" with UHF female connector. Therefore the antenna and the cables are well protected against all weather conditions. The supporting boom is divided in two parts connected together with aluminum tube with mounting consoles enable to mount the antenna on the antenna rotator. Such construction enables easier antenna mounting or even use as "square shaped" antenna with 45° linear polarisation saving us some space under the antenna.

TECHNICAL DATA	
Frequency range	14, 21, 28 MHz
Impedance	50 ohm
VSWR	< 2 (DIAG. 1)
Gain	8,5 dBd (14 MHz) 10 dBd (21, 28 MHz)
Front-to-back ratio	15-25 dB
Front-to-side ratio	> 45 dB
Polarisation	HOR/45°/VERT
Maximum power	1 kW CW, 2 kW PEP
Mass of antenna	30 kg
Supporting elem. length	4,0 m
Boom length	2 x 2,1 m
Diameter of rotation	10 m
Wind area (CxA)	0,45 m ²
Wind velocity	150 km/h

ANTENNA PARTS LIST (Pict. No. 1)

1. Spreader tube 28/24 X 3000	16 pc.
2. Spreader tube 2 (24/20 X 1200)	15 pc.
3. Spreader tube 2S	1 pc.
4. Radiator 14 MHz (S-14)	1 pc.
5. Radiator 21 MHz (S-21)	1 pc.
6. Radiator 28 MHz (S-28)	1 pc.
7. Reflector 14 MHz (R-14)	1 pc.
8. Reflector 21 MHz (R-21)	1 pc.
9. Reflector 28 MHz (R-28)	1 pc.
10. Director 1 14 MHz (D1-14)	1 pc.
11. Director 1 21 MHz (D1-21)	1 pc.
12. Director 1 28 MHz (D1-28)	1 pc.
13. Director 2 14 MHz (D2-14)	1 pc.
14. Director 2 21 MHz (D2-21)	1 pc.
15. Director 2 28 MHz (D2-28)	1 pc.
16. Junction box	3 pc.
17. Stainless Steel Bracelet 24	15 pc.
18. Stainless Steel Bracelet 28	33 pc.
19. Boom	2 pc.
20. Joint element with Console Mount	1 set.
21. SS Screw M8 x 60+M8 nut +M8 washer	4 set.
22. Distant Nylon Rope R-S-D1	3 pc.
23. Distant Nylon Rope R-S1-D1	1 pc.
24. Distant Nylon Rope D2-D1	4 pc.
25. SS Selftapping screw 3,5 X 9,5	32 pc.
26. PVC Strech Ropes	9 pc.

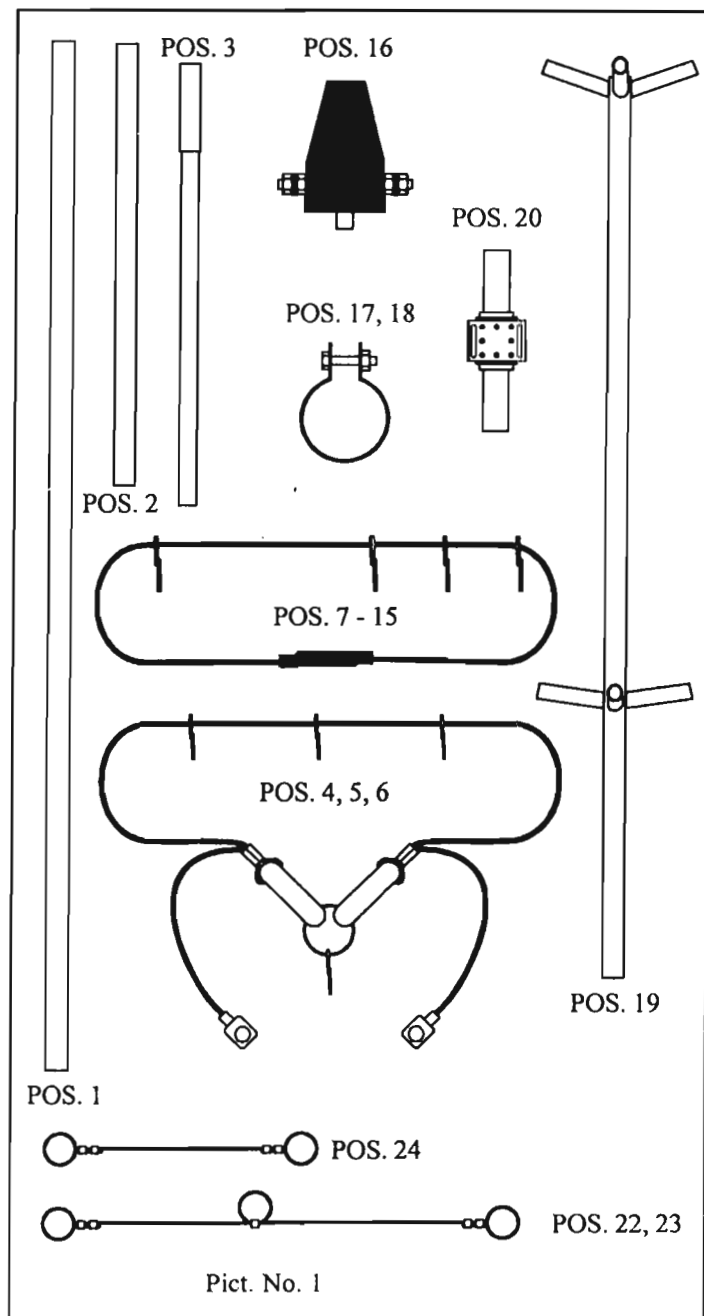

SOME COMMON USEFUL FACTS ABOUT QUAD ANTENNAS

It is big and a little bit clumsy for mounting but still DX-ers appreciate it's excellent electrical characteristics. Many times we try to compare QUAD antennas with YAGI Beams, so here we would like to expose some facts talking about better behaviour of QUADS against YAGI antennas:

- QUAD antennas have full wave full-length elements while most of the YAGIs have 1/2 wave or even shortened elements. Therefore two-elements QUAD has equivalent gain as three or even more elements YAGI beam;
- all elements at the QUAD antenna are DC grounded and therefore they are less sensitive on surround electromagnetic noises;
- the gain and Front-To-Back ratio are dependant from the distances between the elements of the antenna. CUBICAL QUAD antenna design has those distances optimized for each band separately while many multiband YAGI antennas has a compromise at higher and lower bands;
- last but not least at the directional HF DX antennas low radiation angle above the horizon is very important for good DX-ing. This angle is dependant from the height of the antenna above ground. QUAD antennas are less sensitive on the antenna mast height as YAGI antennas. Or in other words - we do not need monster antenna towers for good DX QSO's.

On the pictures below we have "real" radiation patterns for 4-elements HF QUAD antenna AD-14-CQ/C while mounted 5, 10 and 15 meters above average ground. The main lobe radiation angle is approx. 13° above horizon. The gain figure of 16 dBi (14 dBd) is "produced" by the influence of ground - in such cases we must add approximately 3 dB on the typical antenna gain because all the radiated power is now radiated in the upper hemisphere.

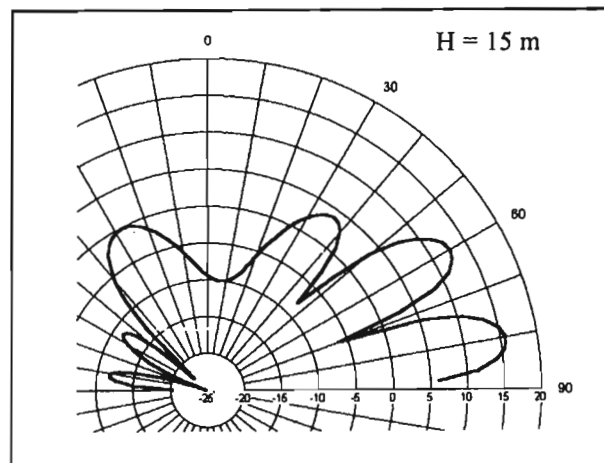
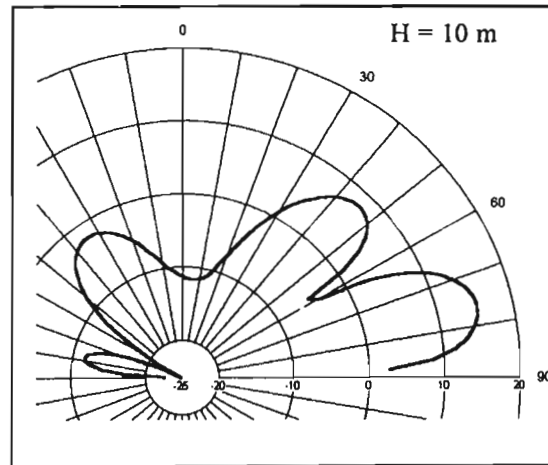
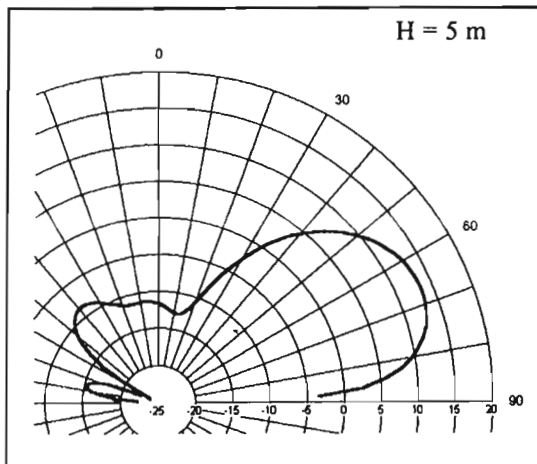

Pict. No. 5a

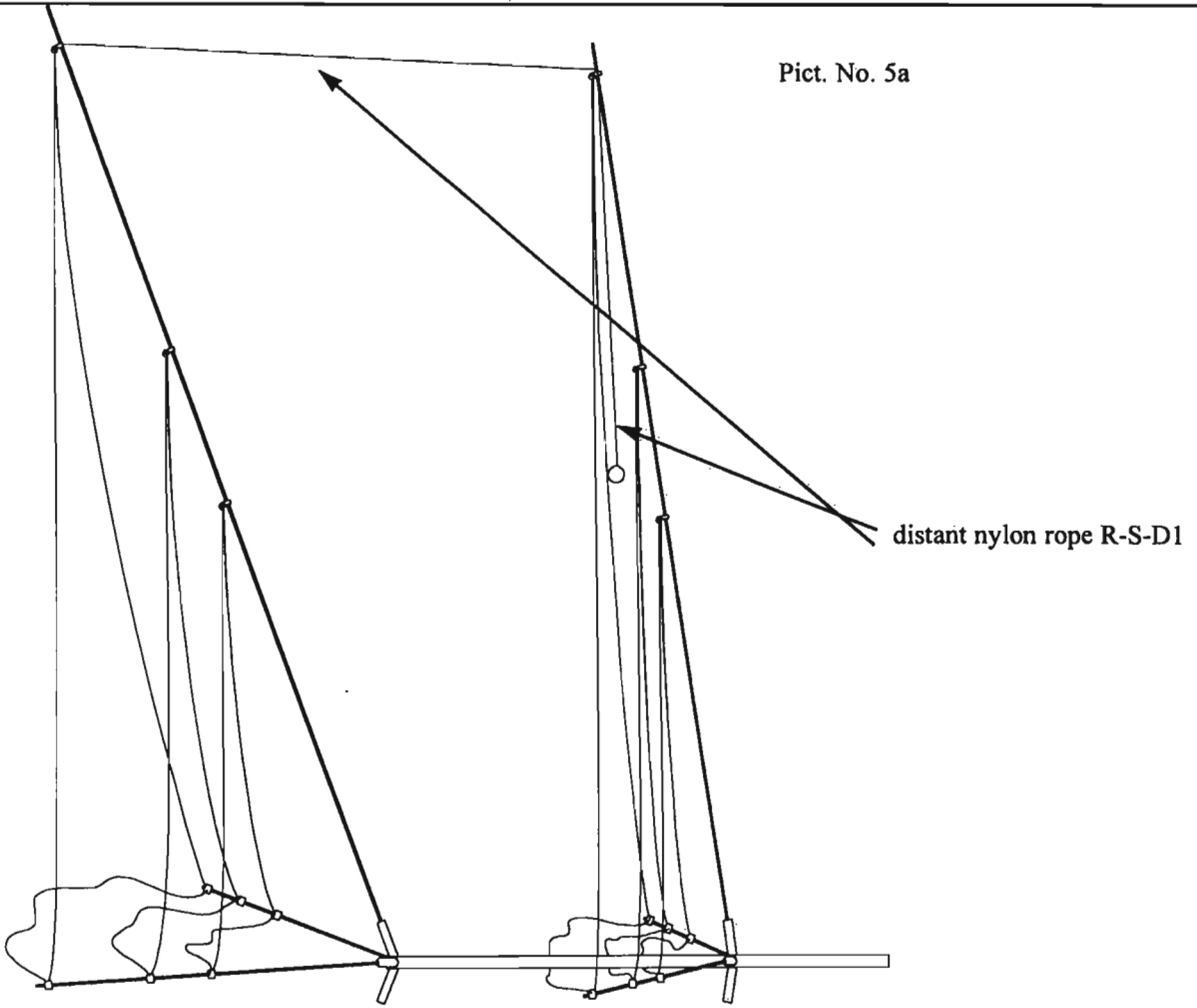

Pict. No. 5b

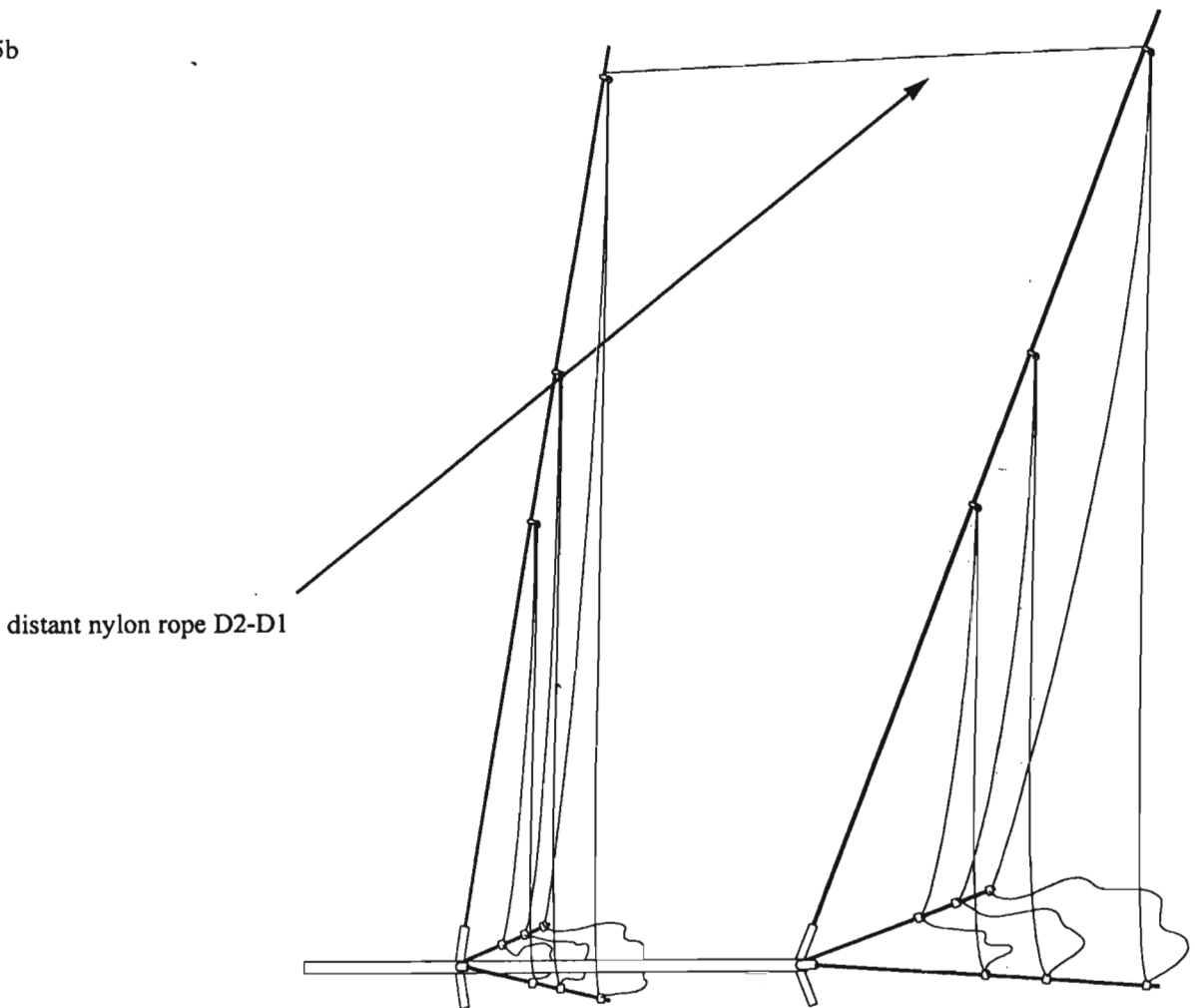

E plane ———
 H plane ———

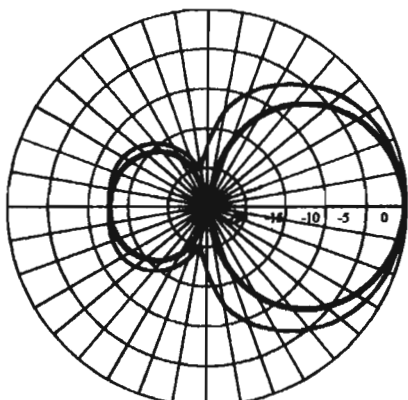

14 MHz

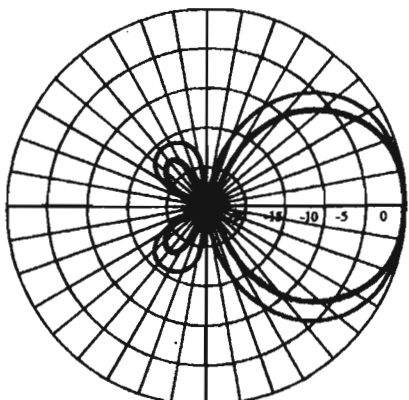

21 MHz

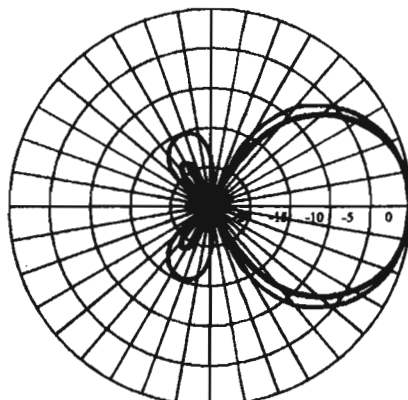

28 MHz

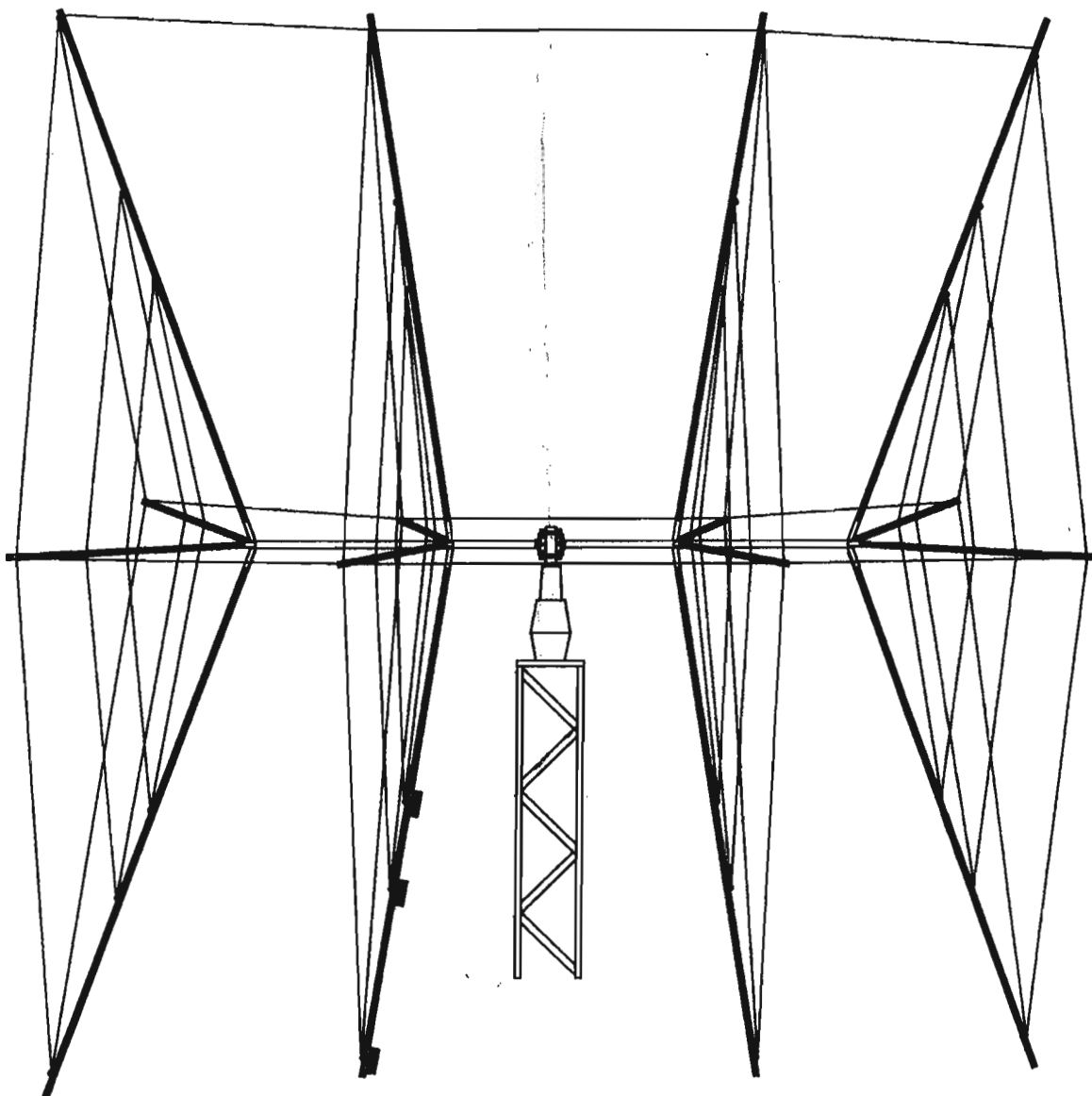
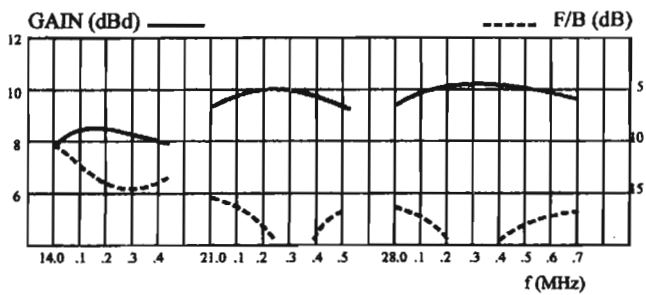
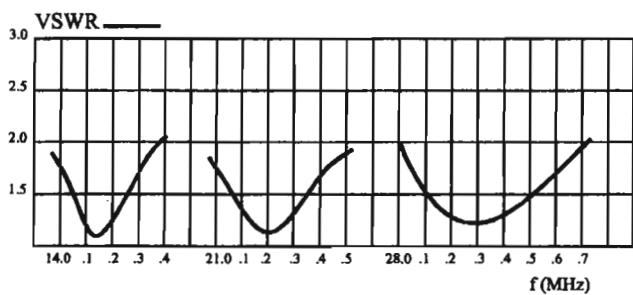

shown on the picture no. 6 and 7. Lift such prepared antenna half to the joint element (already mount to the antenna rotator) and attach it to the joint element without screwing yet and take into account that the engraved letter in the Joint element and Boom are equal.

10. Lift and attach the second halves of the antenna according to the same procedure as before.

11. Now attach the remaining end of the Nylon Distant Rope R-S-D1 on the Spreader of Director 1. We could help with this procedure with rotation of the antenna halves since we could not reach the distant ropes. First attach the upper Distant Ropes and then on the side and at last at the bottom side of the antenna.

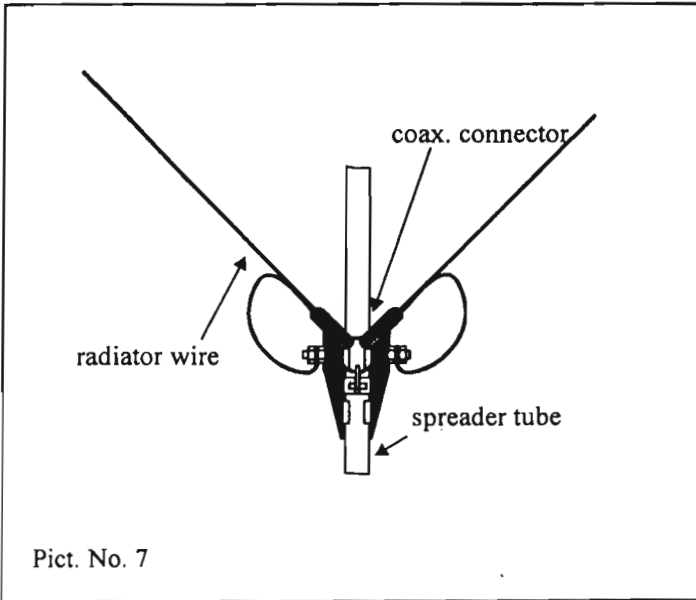

12. Adjust the tension of all wires with adjusting the position of the Bracelet rings on the bottom Spreader.

13. Attach the dipole junction boxes on the bottom spreaders so that the Bracelet Ring will be in the middle of two Junction Box plastic pegs. Attach the cable shoes of the radiating wires as shown in the Picture No. 7). The hole on the Dipole Junction Box is drain hole.

14. Connect the coaxial cables on the connectors on the Dipole Junction Boxes (using separate cables for each frequency band is highly recommended). Attach the coax. cables with the PVC Stretch Ropes.

15. Now the antenna is ready for final attachment to the joint element on the antenna rotator. You could see the picture of the complete antenna on the picture no. 8.

WE WISH YOU MANY PLEASANT HOURS AND MANY DX WITH THE AD-14-CQ/C!

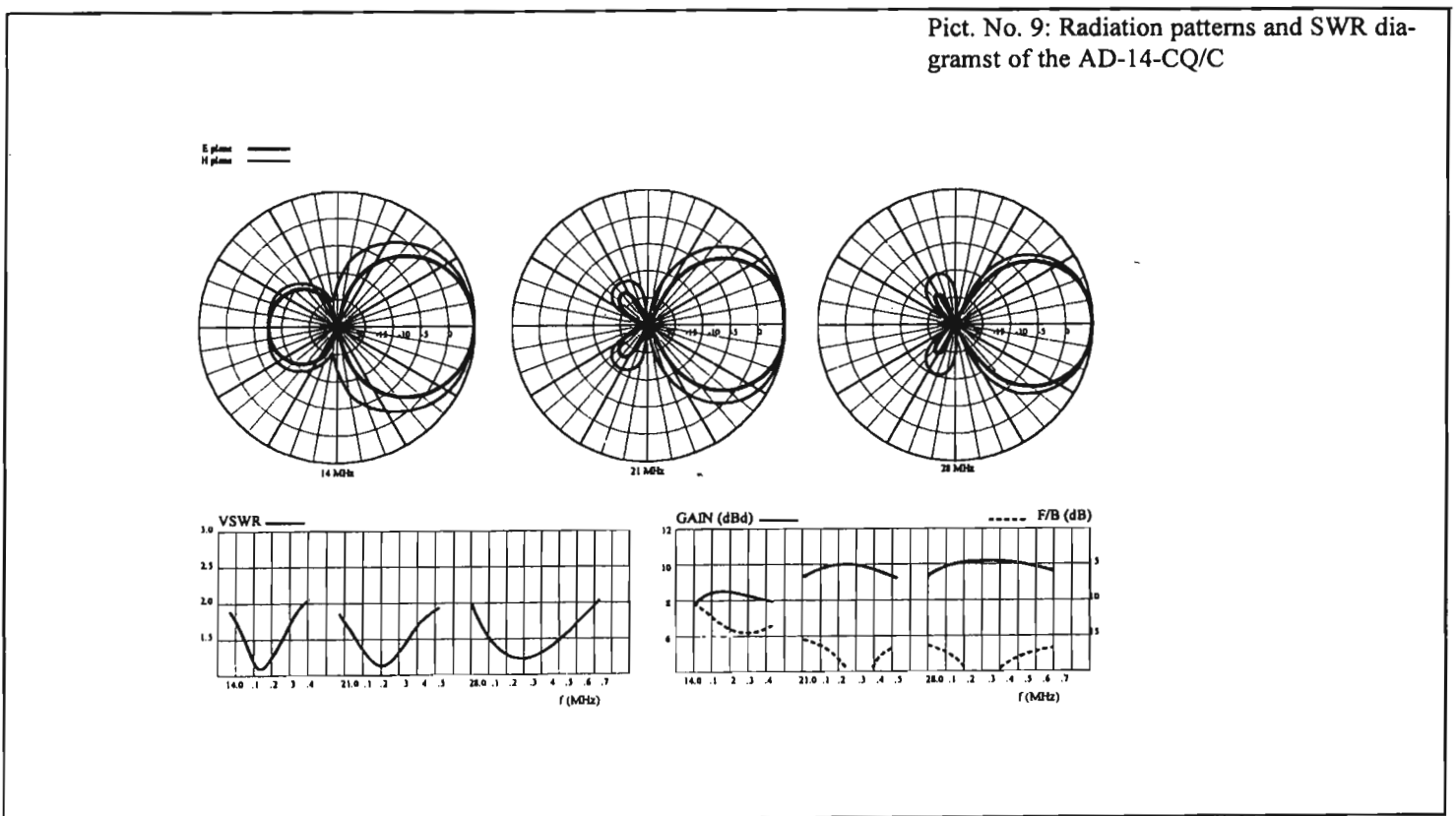

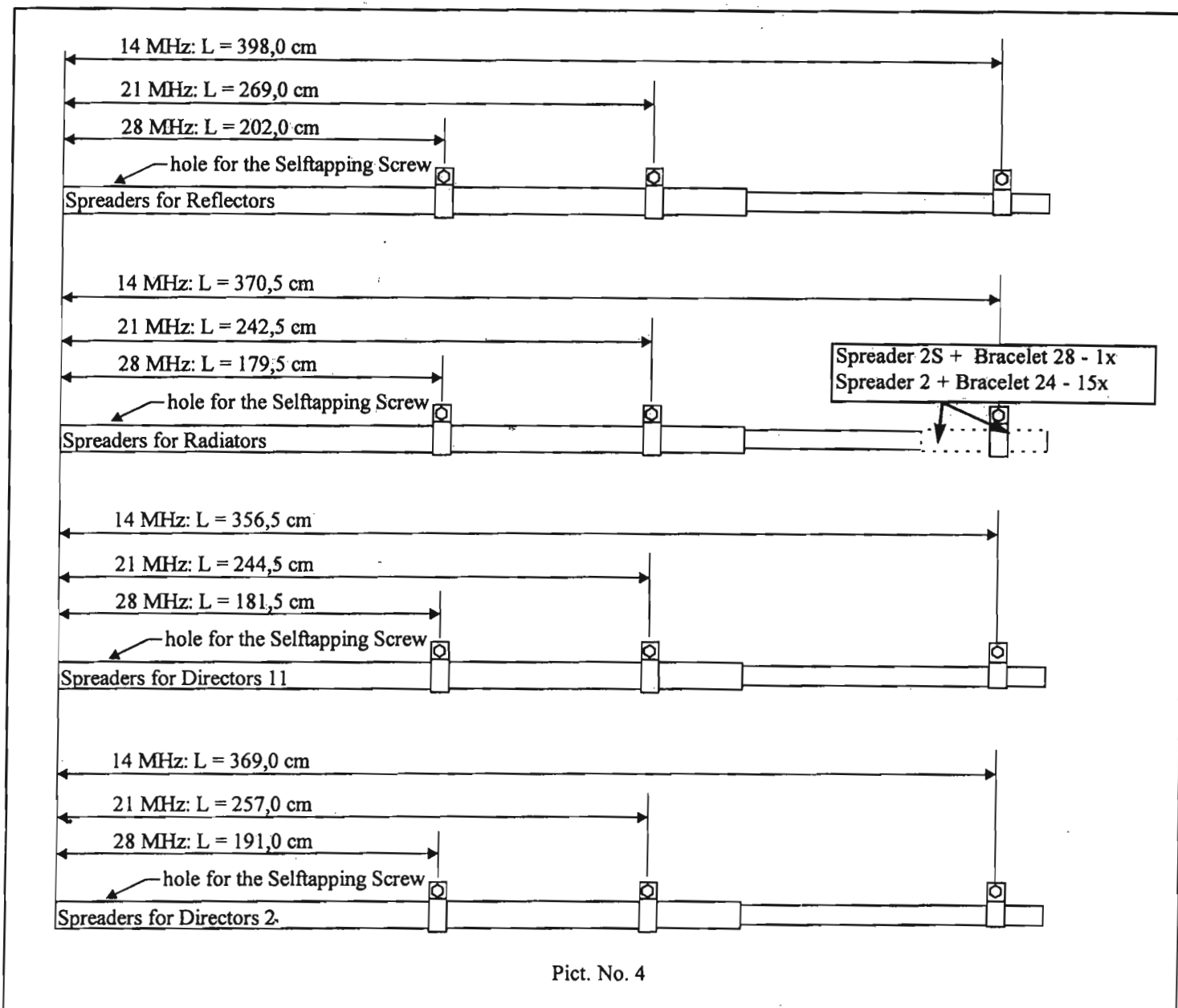

6. Spread all Radiator, Reflector and Director wires on the ground. All wires are equipped with the SS Rings.

7. Attach all Radiator, Director and Reflector wires with the SS Rings on the Screws on Bracelets mounted on the Spreaders starting with the 28 MHz wires (shortest ones), continuing with 21 MHz wires and ending with 14 MHz wires - see the Pict. No. 5a and 5b.

8. Attach the Distant Nylon Ropes on the top of the Spreader Tubes. For easier mounting procedure the Distant Ropes are divided into two parts. First part (Rope R-S-D1) we attach to the Reflector and Radiator Spreader. The second part (Rope D2-D1) we must attach to the Director 1 and Director 2 Spreaders (Pict. No. 5a and 5b). If the antenna will be used in horizontal or vertical polarisation then we will use three such ropes and if 45 degr. polarisation we will use all four ropes.

If we could mount the antenna on the antenna tower in "one piece", then connect both halves of the antenna together with the Joint Element take into account that the engraved letter in the Joint element and Boom are equal. Attach the boom to the joint element with the SS Screws M8, nuts and washers. But if we could not mount the antenna in such way, proceed as follows:

9. With rope and pulley lift one half of the antenna approx. 3 m above ground level. Insert remaining two spreaders in the Boom and attach them with the selftapping screws. Note that the Spreader with the Spreader tube 2S must be inserted where the radiator wire are. Attach the wires to the SS Bracelet Rings as

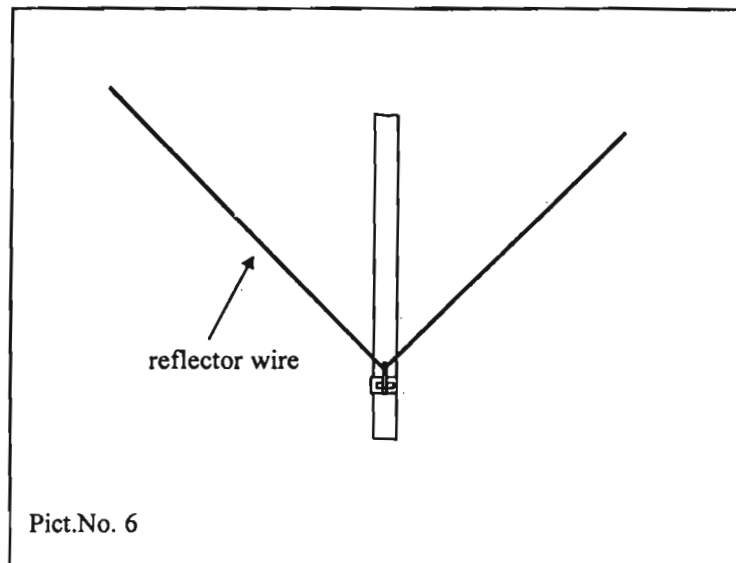

ASSEMBLY INSTRUCTIONS

TOOLS NEEDED: middle size cross-head screwdriver, two wrenches 10, wrenches 13 in 17.

GENERAL INSTRUCTIONS FOR ANTENNA MOUNTING AND ASSEMBLY: due to the antenna size we recommend to have at least three people crew for the antenna installation. Before the antenna installation the rotator must be firmly placed on the antenna tower. To avoid high moment forces produced by the antenna weight to the rotator we recommend using the rotator bearings.

The antenna construction allows us to mount the antenna in various polarisation. Basically the antenna should be used as horizontally polarised (Pict. No. 2) or it could be placed as square shaped thus we get 45 degr. polarisation angle and also we could save some space under the antenna. Vertical polarisation is also possible.

We recommend to assemble the antenna on the safe ground first and then we could lift such antenna with the use of rope and pulley.

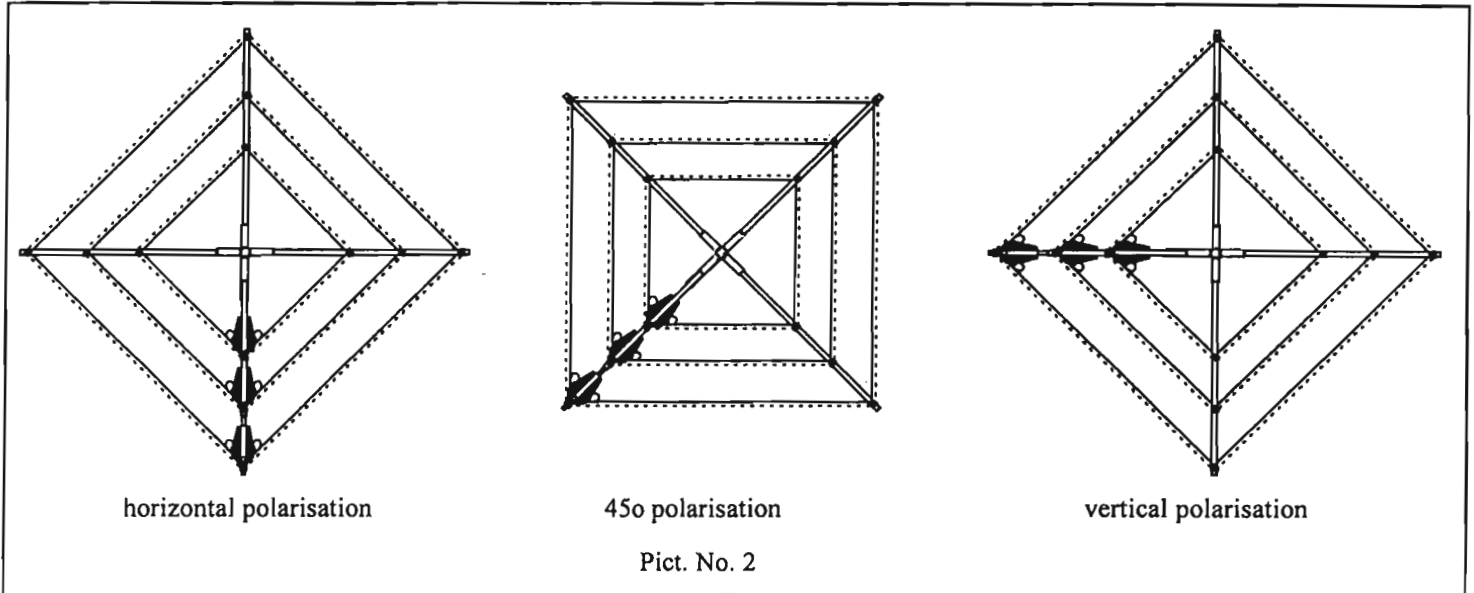

Also we could assemble each half of the antenna separately and then composed both parts together on the top of the antenna tower. In any case never forget - **SAFETY FIRST!** According to many HAMs feedbacks the best solution is by using the mobile lift - the antenna must be assembled on the ground completely and then we could lift it safely and quickly to the rotator height.

MOUNTING AND ASSEMBLY STEPS:

1. Unpack the antenna parts and check the items list first. In case of missing parts contact your local dealer/distributor immediately.
2. Mount together Spreader Tubes 28/24 x 3000 and Spreader Tubes 2 (and 2S) together as shown on the picture no. 3 with using the Selftapping Screws. Note that the holes in the Spreader Tubes are already prefabricated;
3. Put both halves of the Boom on the ground ensuring enough space around the Boom to mount the Spreader Tubes.
4. Put the SS Bracelets on the Spreaders as shown on the Picture No. 4. Put two Bracelets 28 mm on the Spreader Tube 28/24 x

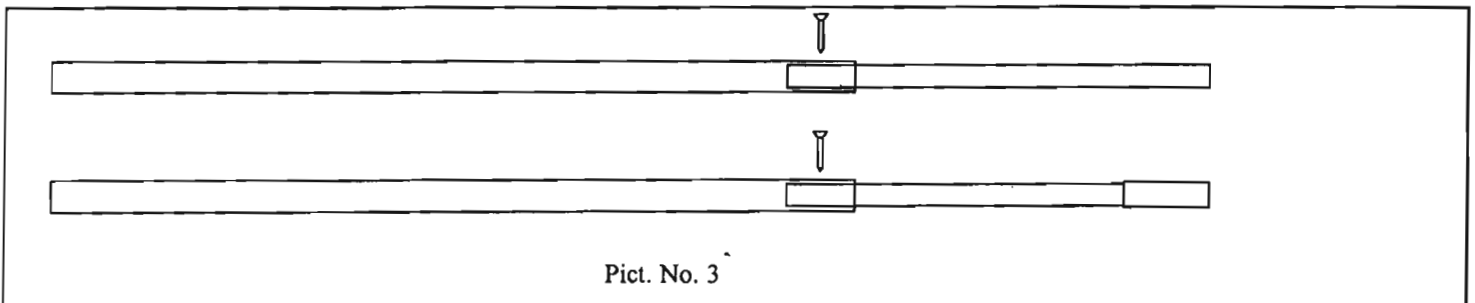

3000 and one Bracelet 24 mm on the Spreader Tube 2 (24/20 x 1200) on the positions as dimensioned on the Pict. No. 4. Note that you must put three Bracelets 28 mm on the Spreader composed with the Spreader Tube type 2S. **NOTE: The screw on the Bracelet must be directed to the same direction as the hole for the Selftapping Screw at the bottom of the Spreader tube.**

5. Now we could insert Spreader Tubes with Bracelet Rings into the Boom. For now insert just four upper and eight side Spreaders and screw the Selftapping screws to fix the Spreaders into the aluminum tubes on the boom. **NOTE: At this moment do not use Spreader composed with the Spreader Tube 2S.**

Reflectors

Radiators

Directors 1

Directors 2

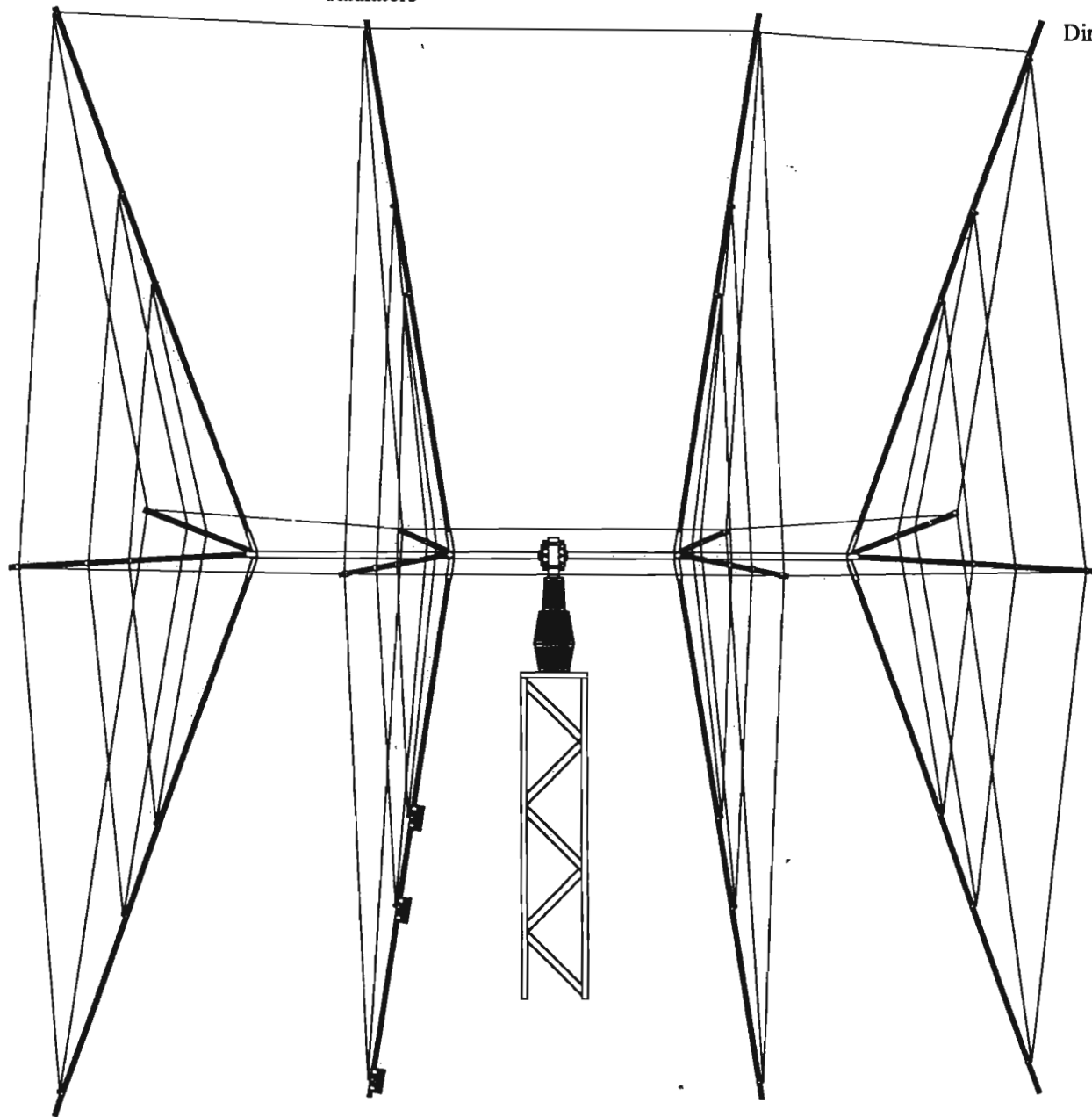

Pict. No. 8