

BHI NEDSP1061-KBD DSP Installation in the Kenwood TS-850S/AT

I can't make any guarantee other than this is how I installed my BHI NEDSP1061-KBD and it works beautifully. I've been running it 24/7 for the last three weeks, so it seems stable enough.

The radio should have the top and bottom covers removed.

The top cover has 2 screws on the front and back edges of the radio, and 1 screw near the central ventilation grating, the screws are circled here:

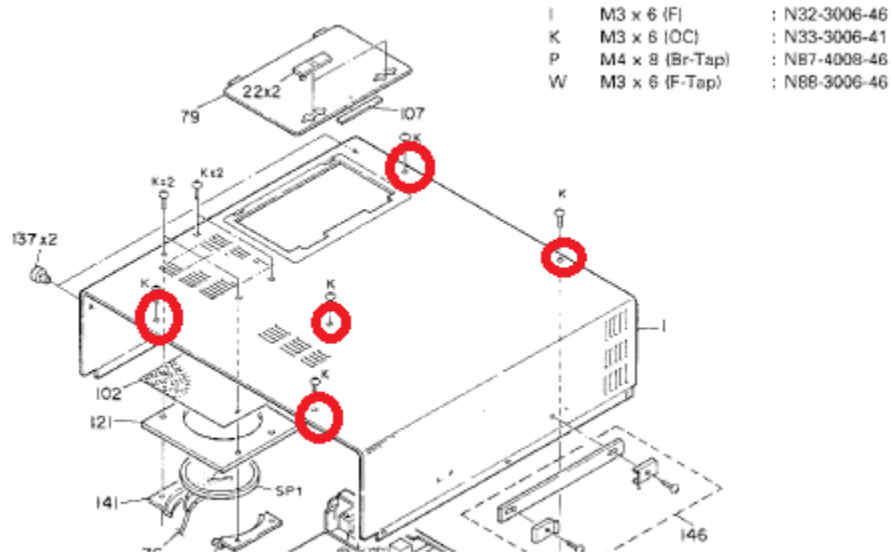

The bottom cover has 9 screws that need to be removed, which are also circled in red:

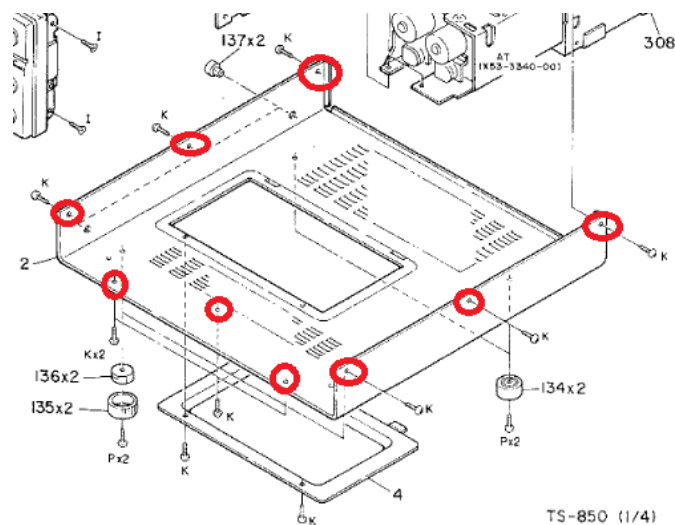

Locate the IF board X48-3080-00 on the bottom of the chassis. We need to remove the IF board to desolder and remove C164. It looks very difficult due to all of the cables, but it isn't so bad. You can take photos and use some temporary labels whilst removing the Molex connectors. Also note that the pin counts are different on many of the connections and that will also help upon reassembly. The ribbon cables can be removed by grabbing each side near the connector, and pulling up. It looks scary but you will get the hang of it fairly quick.

C164 is the coupling capacitor after the AF Pre Amp, and before the AF Power Amp. C164 is circled in red on the diagram.

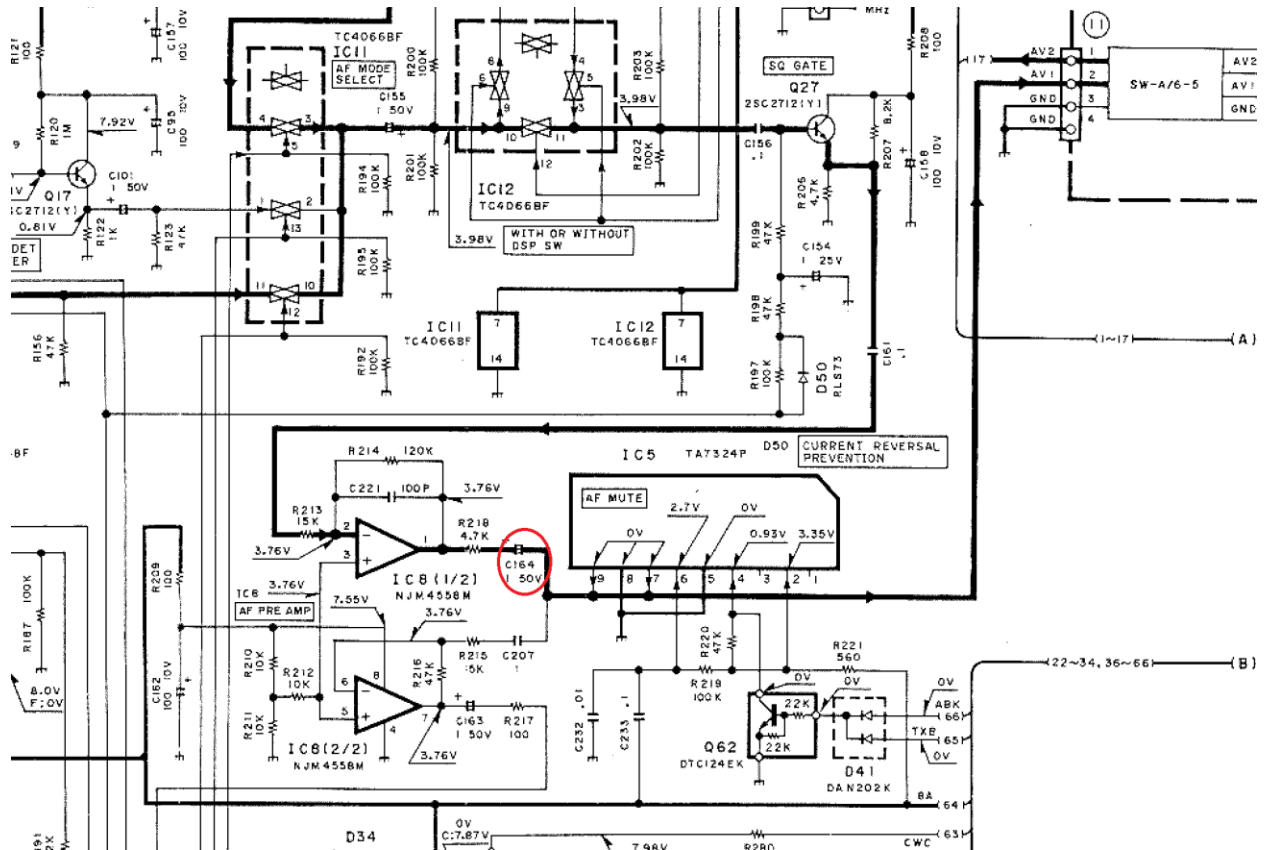

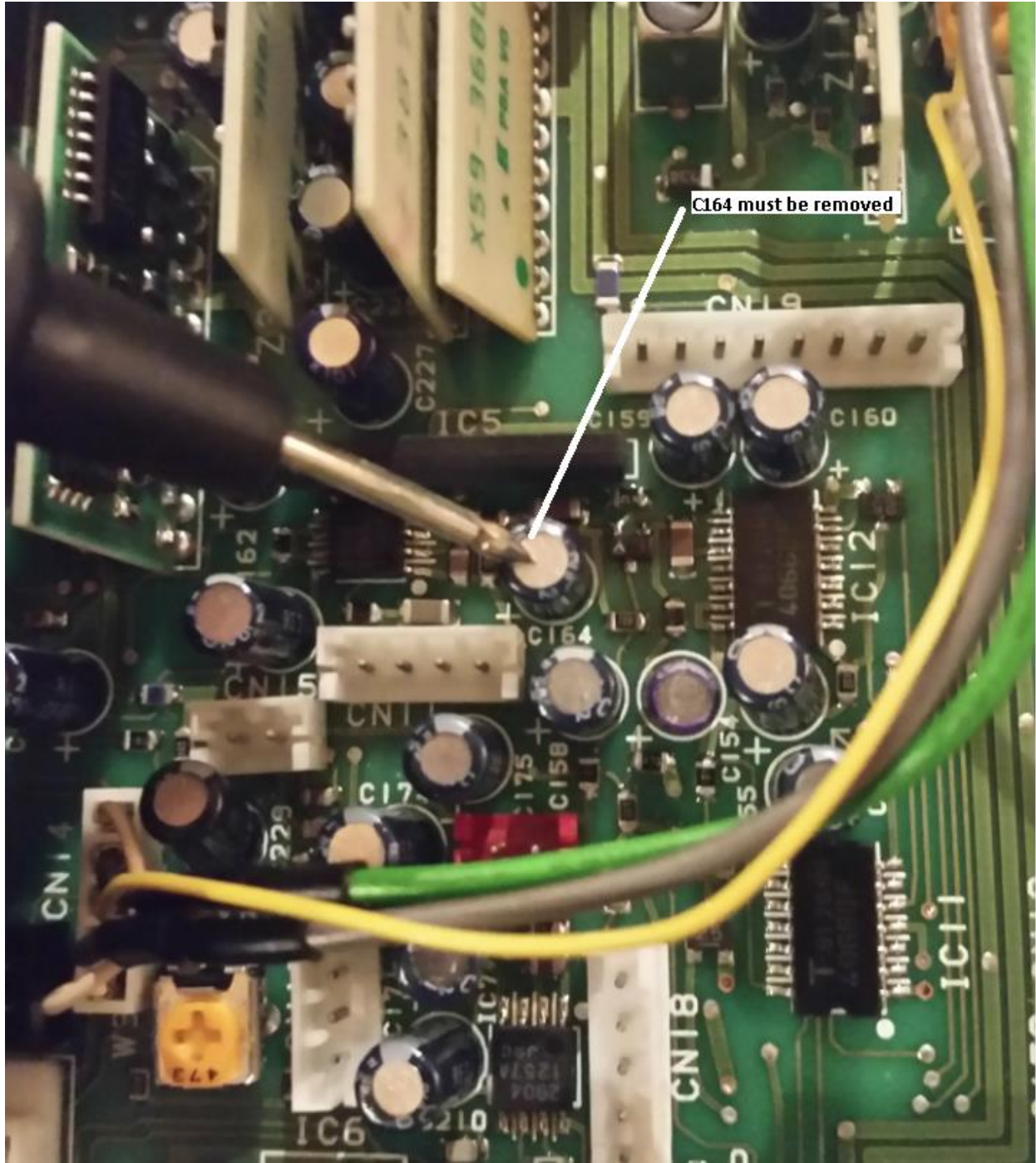

Here is C164. Note that IC5 the AF amp is next to it, and we will employ one pin if that Molex connector CN11 later.

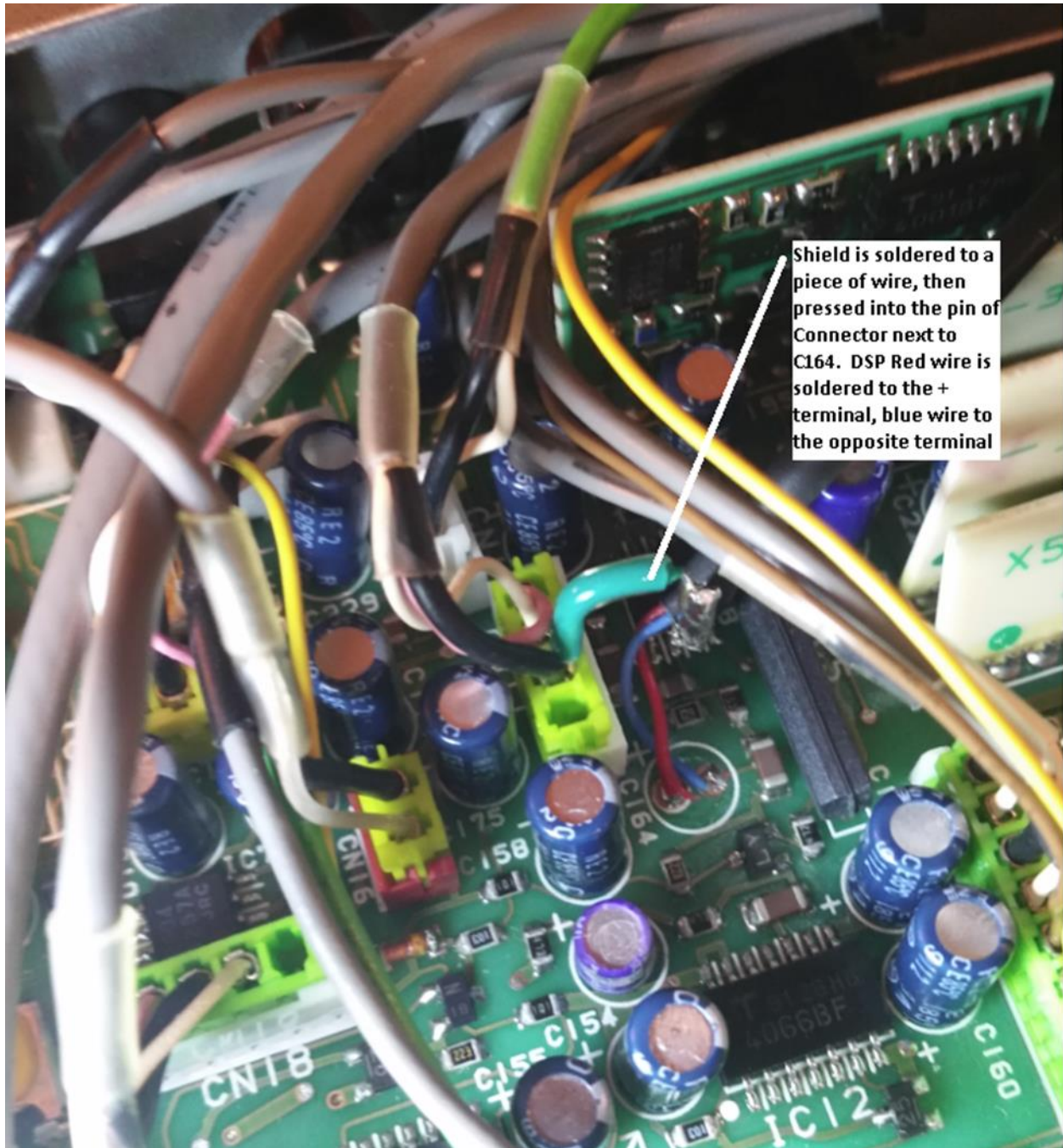

You can see that C164 has been removed from the board and the 2 wires, and the Red wire is soldered to the + side and the Blue wire is soldered to the other side. I "fished" the DSP wires from the top of the chassis and then soldered to the loose board, then reinstalled the board. Note that I soldered a short length of wire to the shield, and then pushed the bare section into the 2nd pin of the Molex connector. You can also see a Black wire in that same pin of the connection.

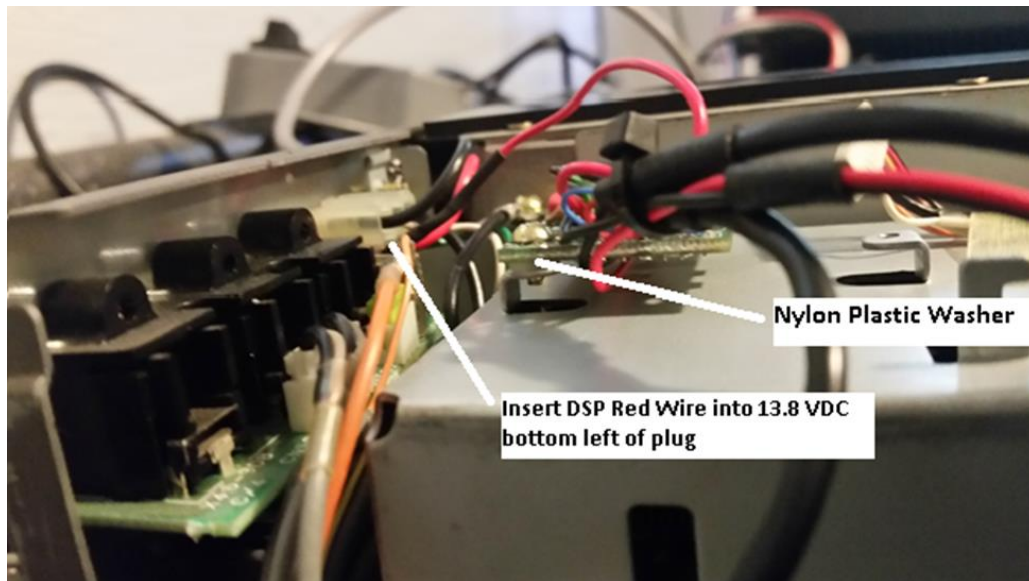
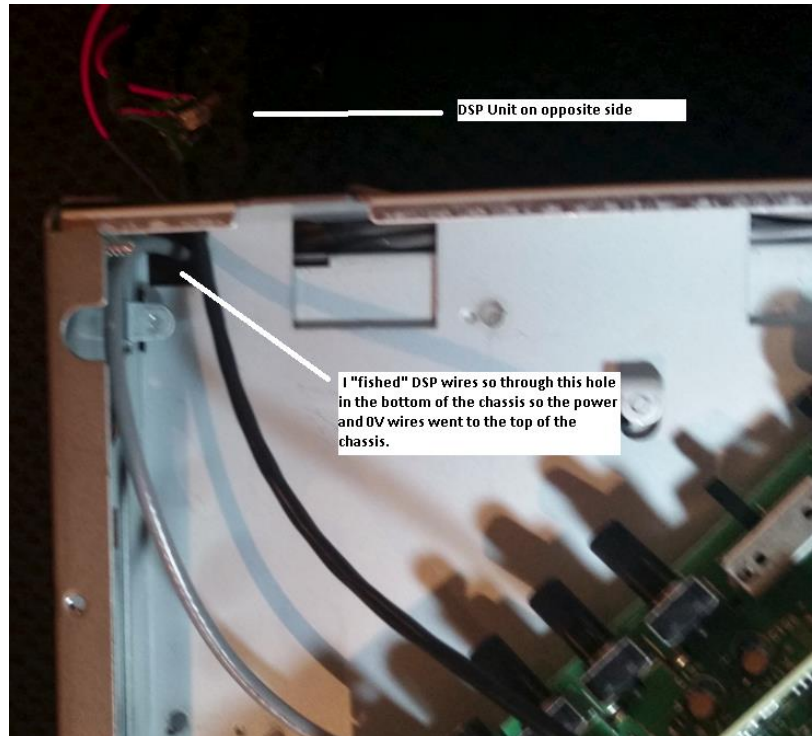

The Nylon washer was perfect to keep the DSP electrically separated from the chassis. The red DSP wire actually has some black heat-shrink tubing on the end, which may not be very clear in this photo. The red DSP wire is pushed into the bottom left corner of the Molex connector.

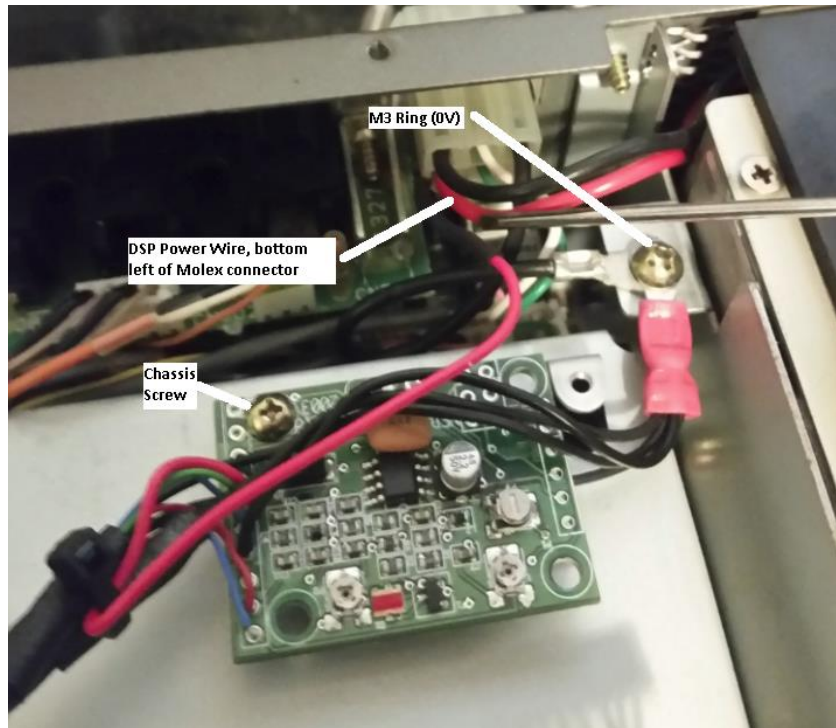

As long as the radio is used in a base location, you don't actually have to solder the Red power wire, the other wire in the Molex plug can hold it in place. The M3 Ring (0V) terminal was placed on top of one of the existing Kenwood terminal. The Chassis screw was "borrowed" from the Kenwood board below the DSP unit.



View of final installation. Note that the DSP switch is resting on double-sided adhesive.

Filter Level Select:

Hold down the DSP power button and power up the TS-850. After **the fourth 2 tone beep** the module enters the filter level select mode. **Release the button after either the 4 or 8 beeps** to select the desired level mode. I waited for 4 beeps (4-step mode) and then released the button. This puts the DSP unit in 4-step mode.

Now, press the button again and you can hear it beep once, twice, three times, four times, and then it repeats the cycle. You can experiment with the levels, more beeps equals more processing. On my radio I prefer 2 or 3 beeps, with 3 being where it is most of the time. Note that you set this up for 8 steps (look at the second bold-face sentence again) if you wish, but I have found that the 4-step mode is easier and faster for me. Note that one small press will turn the DSP off, and it should show an Orange color on the LED. When processing is on, the LED will be green.

There are some fine tuning steps of the potentiometer that is listed in the instruction manual. You can adjust these if needed to get the on-DSP volume level to match the off-DSP volume level, if necessary.

Good luck with your install, and take great pride in the upgrade to your Kenwood TS-850!