



MAGNUM SIX

RF SPEECH PROCESSOR

OUT

IN



LEVEL

MODE

LEVEL



INDEX

		<u>PAGE</u>
SECTION 1.0	INTRODUCTION	1-1
SECTION 2.0	INSTALLATION	2-1
2.1	GENERAL	2-1
2.2	TRANSMITTER/TRANSCEIVER MODIFICATION	D2-4
2.2.1	T4X/T4XB/T4	D2-4
2.2.2	TR3/TR4	D2-6
SECTION 3.0	FINAL INSTALLATION , CALIBRATION AND OPERATION	3-1
3.1	EXPLANATION OF CONTROLS	3-1
3.2	FINAL INSTALLATION	3-2
3.3	CALIBRATION , ADJUSTMENT AND OPERATION	3-4
3.3.1	ADJUSTMENT AND OPERATION	3-4
3.3.2	CALIBRATION	3-6
3.4	ADDITIONAL AVERAGE POWER	3-8
3.5	OPERATING CONSIDERATIONS	3-8
3.6	OPERATION WITH CLASS AB LINEARS	3-9
SECTION 4.0	SCHEMATIC DIAGRAM	4-1
SECTION 5.0	TROUBLE SHOOTING AND SERVICE	5-1

INDEX

		<u>PAGE</u>
DIAGRAMS AND ILLUSTRATIONS		
2.1-1	BLOCK DIAGRAM	2-2
2.2.2-1	T-R RELAY CONNECTION	D2-8
3.2-1	INSTALLATION PICTORIALS/SCHEMATICS	D3-3
3.3-1	OUTPUT RF PATTERNS	3-5
3.3.2-1	CALIBRATION CHART	3-7
4.0	SCHEMATIC DIAGRAM	4-1

ERRATA

Paragraph 2.2.1 (T4XC)

Route the MAGNUM SIX cables through the "B" hole in the back chassis (next to the power connector).

Paragraph 2.2.2 (TR3/TR4) Page D2-7

In the second from last step, BE SURE TO STUDY THE RELAY CONNECTIONS OF YOUR LINEAR AMPLIFIER. IF ANY DOUBT EXISTS THAT VOLTAGE FROM YOUR LINEAR MAY APPEAR ON THE RELAY SWITCHING LINE, USE AN EXTERNAL DPDT RELAY CONNECTED AS SHOWN BELOW TO PRECLUDE DAMAGE TO YOUR MAGNUM SIX.

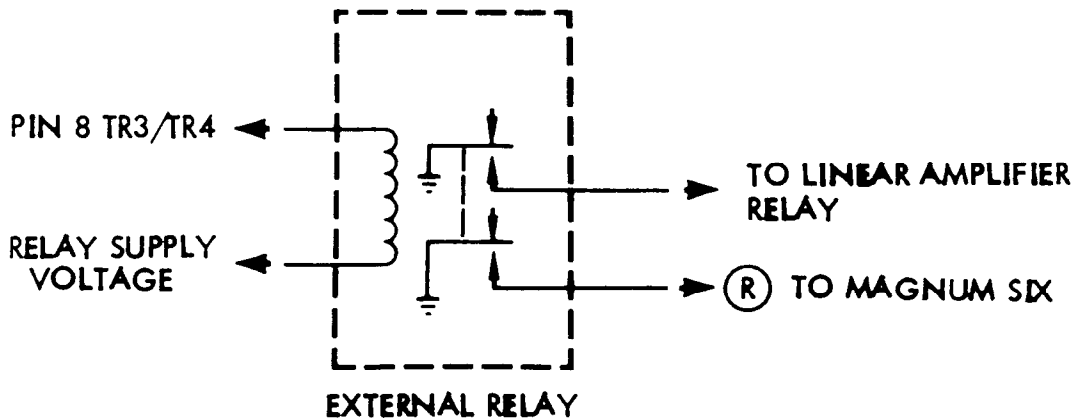

1.0 INTRODUCTION

You have just purchased a quality unit which is the most advanced and thoroughly developmental and production tested RF Speech Processor available to the discerning amateur radio operator!

The MAGNUM SIX is quality engineered in every respect and all components have been specially selected to assure long life with trouble-free operation. Each unit is subjected to a minimum of 24 hours of continuous "burn-in" operation before final test, inspection and assembly into its case. The layout and construction of your new MAGNUM SIX incorporates state-of-the-art aerospace engineering techniques to assure maximum port-to-port isolation, uses a selected bandpass filter and is constructed with ground plane double-sided glass epoxy circuit board material.

Your MAGNUM SIX has been designed and developed by experienced professionals who are also ardent radio amateurs. Our goal has been to achieve a significant advance in amateur radio SSB communications. We know that once you have properly placed your MAGNUM SIX on the air, you will agree that we have achieved that goal.

Good luck and good DX!

2.0 INSTALLATION

2.1 GENERAL

Figure 2.1-1 is a block diagram depicting the functional relationship between the MAGNUM SIX RF Speech Processor and your transmitter or transceiver.

The MAGNUM SIX processes your RF signal after the carrier has been nulled and a DSB (double sideband) signal has been generated in the Balanced Modulator. (See your manual under "Circuit Description".) The DSB signal is first amplified in the MAGNUM SIX and passed through a bandpass filter. The desired sideband signal is passed through this filter and, at this point, the signal becomes SSB (single sideband) with the identical characteristics of your original equipment. The SSB signal then follows one of two possible paths through the MAGNUM SIX that is selected by the operator using the MODE control. In the MODE OUT position, the SSB signal is routed from the filter through a source follower FET, for impedance matching, and then reinserted into the transmitter. In the MODE IN position, the SSB signal is routed from the filter through a source follower FET (separate from the one used in the MODE OUT position) and then into a specially selected and bias-trimmed IC op amp (integrated circuit operational amplifier) where the peak amplitude signals are clipped to form symmetrical square waves and the lower amplitude signals are raised to higher relative levels by ≥ 6 db. The clipped and amplified output of the IC is then reinserted into the transmitter at the same voltage level that was achieved prior to installation of the MAGNUM SIX.

This partially processed clipped signal contains many undesired (splatter) harmonic components because of the nonlinear Fourier series

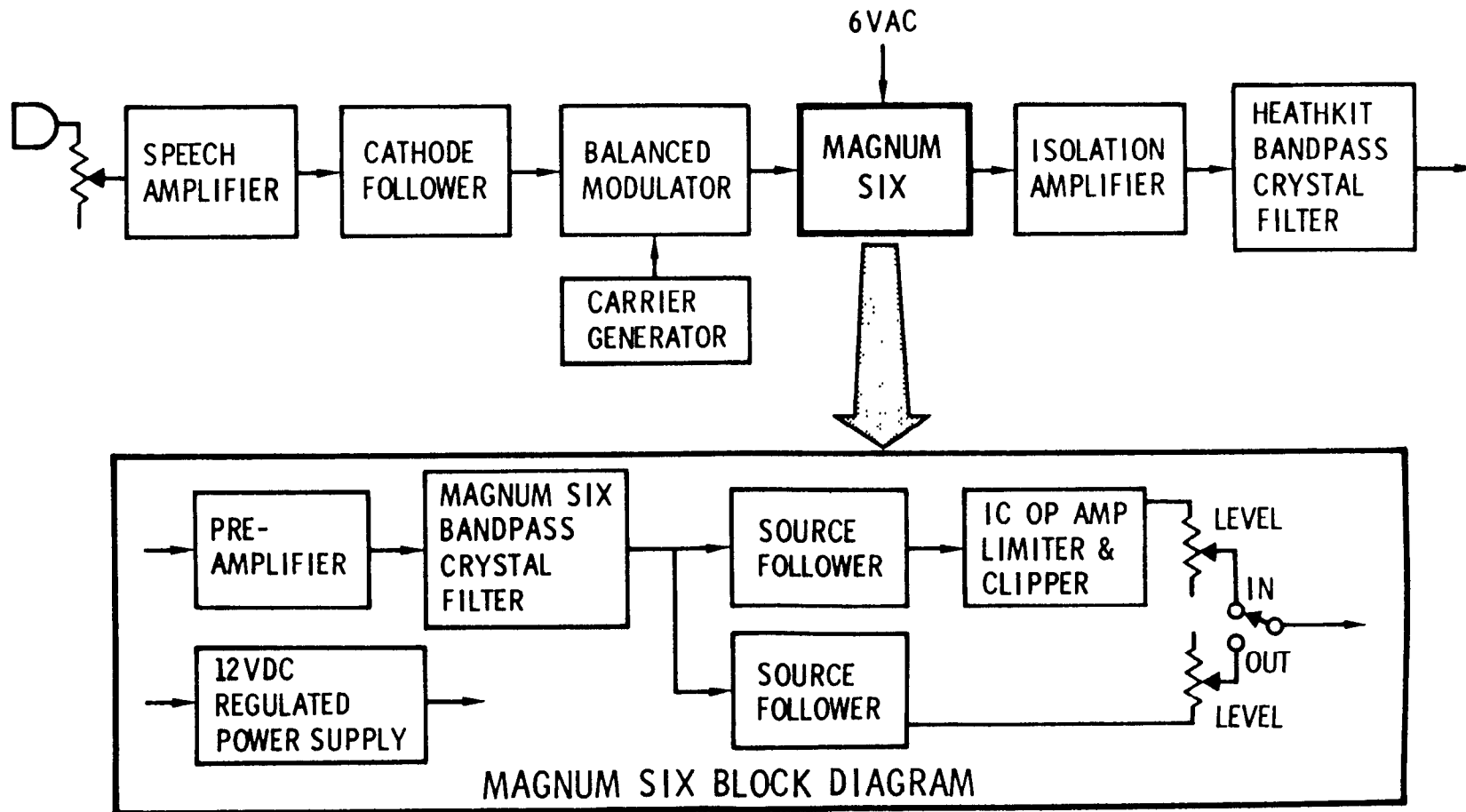

FIGURE 2.1-1 BLOCK DIAGRAM

operation being performed on it during clipping. These harmonics all lie outside the passband of the bandpass filter and are cleanly removed when the signal is passed out of the MAGNUM SIX and on through the original filter stage in your equipment, which becomes the "umbrella" filter of the system. This second filtering comprises the final step in achieving high quality RF speech processing.

The MAGNUM SIX for the Drake equipment uses two filters and a relay to select which is in the circuit. The relay is controlled by a front panel sideband selector switch.

This choice of the MAGNUM SIX filter, and the arrangement of its amplifier and clipper stages relative to the Balanced Modulator and crystal filter of your original equipment, has three significant advantages over other RF Speech Processors:

- 1) When in the IN MODE, retention of the same narrow bandwidth output as the original equipment is assured.
- 2) When in the OUT MODE, the signal is passed through two bandpass filters in series which will produce a narrower and cleaner output signal than the original equipment is capable of, since the tolerances of the two filters around the center frequency will be additive in the narrower bandpass direction.
- 3) In the case of transceivers, the MAGNUM SIX is installed with NO ALTERATIONS in the receiving channel.

2.2 TRANSMITTER/TRANSCEIVER MODIFICATION

It is recommended that you consult your applicable Drake manual and the pictorials and schematics that are referenced therein in addition to this manual as you proceed with the equipment modification. The installation of the MAGNUM SIX into your Drake equipment requires no holes or other permanent non-reversible steps which could deface or lower the trade-in value of your set!

An installation wire harness has been furnished with the MAGNUM SIX to facilitate modification of your equipment. The following steps are sequentially ordered to provide simple and proper modification of your rig. As each step is performed, a ✓ should be placed in the () and you should then proceed to the next operation. Complete modification of your equipment should take approximately one to two hours! DO NOT RUSH THE JOB - FOLLOW THE DIRECTIONS EXACTLY AND CHECK EACH STEP FOR ACCURACY AND WORKMANSHIP BEFORE YOU PROCEED TO THE NEXT STEP.

- () Disconnect all power and equipment interconnect wiring from your transmitter/transceiver.
- () Remove the top and bottom cabinet halves from your set and place aside from your work area.
- () Place your rig bottom side up on the bench with the front panel facing toward you.

2.2.1 T-4XB TRANSMITTERS/T-4 RECITER

- () Refer to the schematic for your set as follows and observe the electrical orientation of the output of Transformer T2 to the sideband selection switch. Note that the transformer is connected to the switch by means of a coaxial cable.

T-4X - Last page of Drake Manual

T-4 - Next to last page of Drake Manual

- () Refer to the applicable photographs as follows and locate T2 and its coax:
 - T-4X - Figure 16, page 39 T4XC Figure 5-2, Page 5-7
 - T-4XB - Figure 14, page 35
 - T-4 - Figure 14, page 37
- () Using a low wattage, pencil-type soldering iron, (Ungar or equivalent), carefully heat and remove the coax center conductor and shield from T2. BE SURE TO REMEMBER WHICH T2 TERMINAL WAS CONNECTED TO THE CENTER CONDUCTOR AND TO THE SHIELD. You may leave the coax in the wire bundle. Dress the free ends of the cable so that they are away from all other connections and terminals.
- () Route the MAGNUM SIX cable harness from the top side of the chassis through the slot that is between the VFO subchassis and the subchassis containing the 6AU6, OA 2, and 12AX7. See Figure 15, page 38, for the T-4X, Figure 13, page 34, for the T-4XB and Figure 14, page 36, for the T-4. Note that in the case of the T-4, there is no slot between the tube-containing subchassis and the VFO blanking plate. Remove the plate and save for replacement if you desire to remove the MAGNUM SIX in the future.
- () Carefully solder the center conductor and shield lead of the MAGNUM SIX cable labeled "IN" to the proper terminals of T2.
- () Trace the path of the disconnected coax along the cable bundle and observe that it passes through a slot in the subchassis assemblies between the VFO and the Filter/Sideband Selection switch.
- () Pass the MAGNUM SIX cable bundle and up through the slot with the existing coax. Invert the chassis so that it is tube side up.
- () Remove the existing coax center conductor and shield from the switch assembly and replace with the MAGNUM SIX "OUT" coax. Dress the unused coax so that it is out of the way.
- () Reinvert the chassis (tube side down) and locate pin 5 of tube V10. Refer to the applicable photograph in your Drake manual to locate the tube socket.

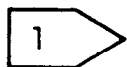
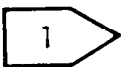

See ERATTA sheet for T4XC

This pin has 2 VAC power available for powering the MAGNUM SIX. Solder the MAGNUM SIX "PWR" lead to terminal 5 of V10. For a neat installation, the wire wraps of the Drake cable harness may be opened and the MAGNUM SIX cables can be carefully laid into the bundle and the wires rewrapped.

- () Replace the bottom and top cabinet halves and run the MAGNUM SIX cable set out through the back of your transmitter between the final amplifier shield cage and V2. This completes the modification of your transmitter.

2.2.2 TR-3/TR-4 TRANSCEIVERS

- () Refer to the schematic of your transceiver in your Drake manual (TR-3, last page; TR-4, foldout between pages 47 and 48). Locate transformer T13 and note that it connects to the Sideband Selection Switch by means of a coaxial cable.
- () Refer to the applicable photographs as follows and locate T13 and its coax:
 - TR-3 - Figure 11, page 29
 - TR-4 - Figure 14, page 34
- () Using a low wattage, pencil type soldering iron, (Ungar or equivalent), carefully heat and remove the coax center conductor and shield from T13. BE SURE TO REMEMBER WHICH T13 TERMINAL WAS CONNECTED TO THE CENTER CONDUCTOR AND TO THE SHIELD.
- () Route the MAGNUM SIX cable harness from the top side of the chassis through one of the chassis holes between tube V5 and T13. See Figure 10, page 28, for the TR-3 and Figure 13, page 33, for the TR-4.
- () Carefully solder the center conductor and shield lead of the MAGNUM SIX cable labeled "IN" to the proper terminals of T13.
- () For the TR-3, splice the center conductor and shield lead of the MAGNUM SIX cable labeled "OUT" to the center conductor and shield, respectively, of

the free end of the coax that was previously removed from T13 and which leads to the Sideband Selector Switch. Carefully solder these connectors and insulate with plastic tape. Neatly dress the spliced cable into the chassis.

- () For the TR-4, trace the path of the disconnected coax and observe that it passes in front of the bandpass filters and connects to the Sideband Selector Switch on the top side of the chassis.
- () Pass the MAGNUM SIX cable labeled "OUT" along the path of the existing cable and up to the Sideband Selector Switch.
- () Remove the existing coax center conductor and shield from the switch assembly and replace it with the MAGNUM SIX "OUT" cable. The disconnected original cable may either be removed or dressed so that it is out of the way and saved for later retrofit to original condition.
- () Reinvert the chassis and locate pin 4 of tube socket V14. This pin has 12 VAC power available for powering the MAGNUM SIX. Solder the MAGNUM SIX "PWR" lead to pin 4 of V14.
- () Refer to the schematic of your transceiver and note that terminals 5 and 8 of the rear chassis power connector are connected to contacts of the receive/transmit relay K1. These contacts and terminals 5 and 8 of the connector are used for control of an external relay for linear amplifier operation. See Figure 2, page 10, for both the TR-3 and TR-4. Note that these contacts control the supply voltage to the external relay. CHECK YOUR PARTICULAR INSTALLATION TO ASSURE THAT THESE CONTACTS ARE WIRED TO INTERRUPT THE GROUND SIDE OF THE POWER LINE. These contacts connected to pins 5 and 8 of the power connector will also be used to actuate the receive/transmit relay in the MAGNUM SIX. To avoid damage to the MAGNUM SIX, it is essential that the above PRECAUTION BE STRICTLY OBSERVED!!
- () Refer to Figure 2.2.2-1 of this manual and Figure 11 of the TR-3 manual or Figure 14 of the TR-4 manual and locate the underchassis feed through connections of relay K1 as shown in Figure 2.2.2-1.

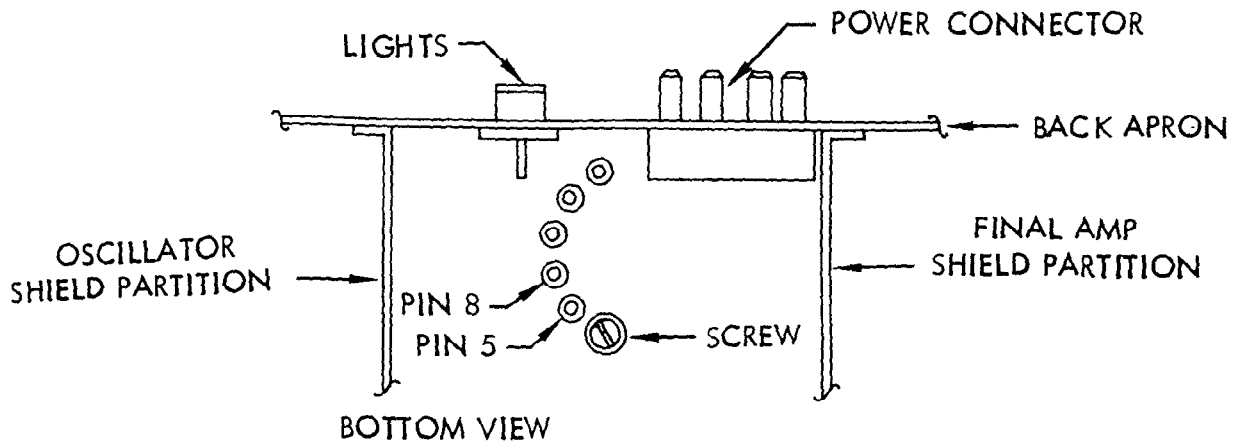

FIGURE 2.2.2-1

- () If you are using pins 5 and 8 for external relay control, ascertain which pin is connected to ground in your installation. If you are using an AC-4 power supply, these terminals will appear at the "VOX RLY" connector of your power supply and may be checked with the use of an ohmmeter with the interconnect cable between your set and the power supply installed. BE SURE THAT THE POWER SUPPLY IS NOT CONNECTED TO THE AC LINE when this measurement is accomplished. Orient the plug at the "VOX RLY" connector of your power supply such that terminal 5 is ground.
- () If you are not using the external control function of relay K1, connect a short piece of hook-up wire from pin 5 of Figure 2.2.2-1 and solder to chassis ground.
- () Connect the MAGNUM SIX lead labeled "R" to pin 8 of Figure 2.2.2-1.
- () Neatly dress the newly installed cables into your chassis.
- () Replace the bottom and top cabinet halves and run the MAGNUM SIX cable set out through the back of your transceiver between the final amplifier shield cage and T14. This completes the modification of your transceiver.

3.0 FINAL INSTALLATION, CALIBRATION AND OPERATION

3.1 EXPLANATION OF CONTROLS

The MAGNUM SIX derives its AC power input from the filament voltage available in your equipment. Consequently, the all-solid-state MAGNUM SIX is instantly, safely and automatically energized by its own regulated power supply upon placing your transmitter or transceiver in the ON function position.

The MAGNUM SIX has three controls: A two-position MODE switch, located in the center of the panel; and two level adjustment controls, LEVEL OUT located to the left and LEVEL IN to the right of the MODE switch. When the MODE switch is in the OUT position, the LEVEL OUT control adjusts the transmitter drive level for "straight-through" operation without RF speech processing. When the MODE switch is in the IN position, the LEVEL IN control adjusts the transmitter drive level with RF speech processing.

THE SETTING OF THE MIC GAIN CONTROL OF YOUR TRANSMITTER CONTROLS THE QUANTITY OF RF CLIPPING TO BE OBTAINED WHEN THE MAGNUM SIX IS INSTALLED AND NOT THE POWER OUTPUT AS BEFORE. EXCESSIVE ADVANCEMENT OF THE MIC GAIN CONTROL WILL CAUSE OVERCLIPPING, DISTORTION AND LOSS OF VOICE QUALITY!

The proper setting of the MIC GAIN control for most installations is APPROXIMATELY AT THE 9 POSITION. Attainment of proper transmitter drive should be accomplished by the MAGNUM SIX LEVEL CONTROLS while the MIC GAIN CONTROL is in the NOMINAL 9 POSITION. The correct settings of the LEVEL OUT and the LEVEL IN CONTROLS will vary from transmitter to transmitter depending on several factors such as; tolerances resulting from manufacture, usage and aging of components and tubes, microphone selected, your voice characteristics, etc.

IMPORTANT !!

THIS SWITCH MUST BE IN THE SAME POSITION AS
THE SIDEBAND SELECTOR SWITCH OF YOUR DRAKE
EQUIPMENT FOR PROPER OPERATION

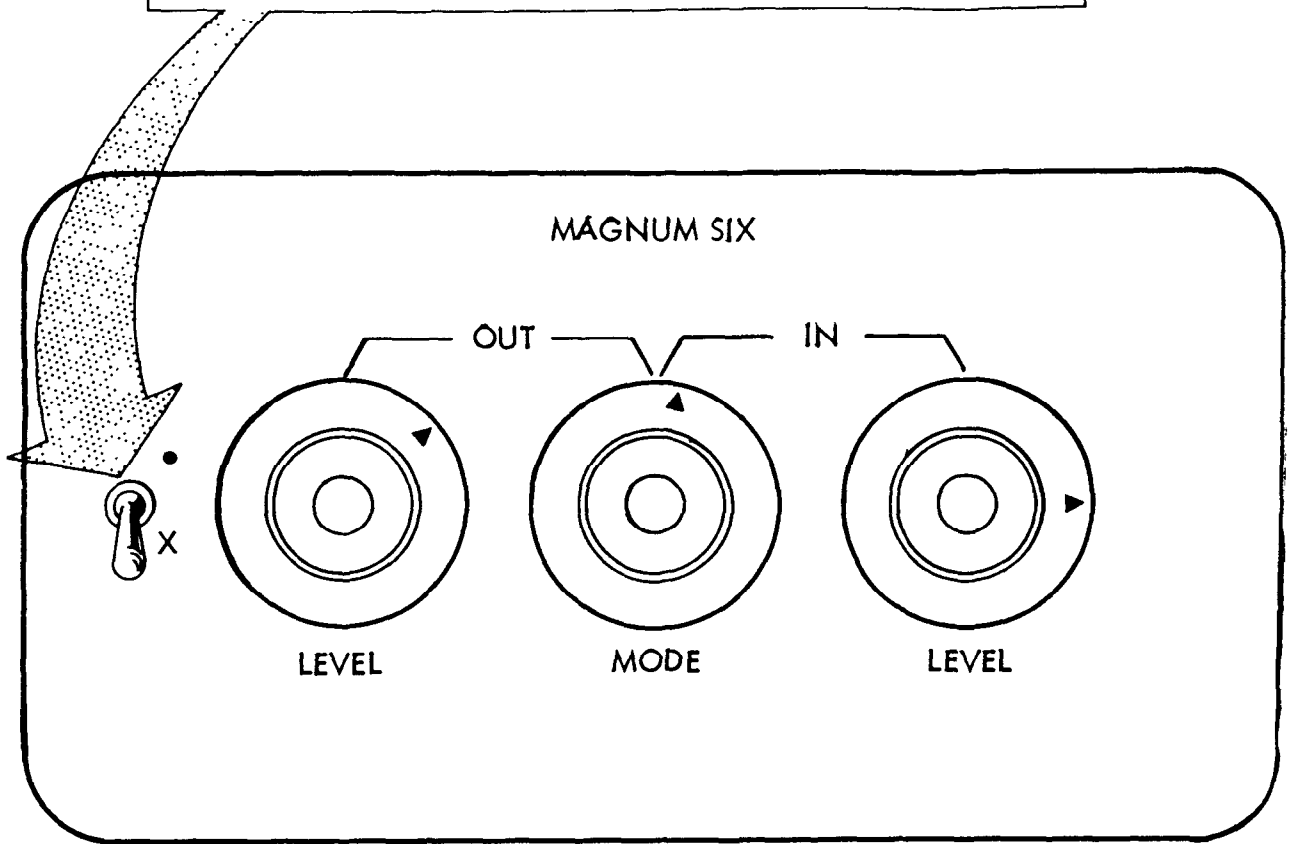

WHEN CHANGING SIDEBANDS ON YOUR DRAKE EQUIPMENT
REMEMBER TO ALSO CHANGE SIDEBANDS ON YOUR MAGNUM SIX

When your MAGNUM SIX has been adjusted in accordance with the instructions that follow, the processed signal transmitted from your equipment will have an average power increase of 6 db (four times the average power)! From many on-the-air reports, it has been observed that a MAGNUM SIX processed voice will contain considerably more "FULLNESS" and "TALK POWER" than before. In addition, it has been reported that RF processed SSB is actually more pleasant to copy because of the "FULLNESS" without regard to the increased signal strength.

CAUTION

CAUTION

CAUTION

CAUTION

JUST AS IS POSSIBLE WITHOUT THE MAGNUM SIX, IMPROPER ADJUSTMENT OF YOUR EQUIPMENT WITH THE MAGNUM SIX CAN RESULT IN ONE OR MORE OF THE FOLLOWING UNDESIRABLE RESULTS:

1. OPERATION OF YOUR LINEAR AMPLIFIER BEYOND THE LEGAL LIMITS PRESCRIBED BY THE F.C.C.
2. SEVERE SHORTENING OF THE LIFE OF YOUR EQUIPMENT'S TUBES AND TANK CIRCUIT COMPONENTS.
3. POWER SUPPLY OVERLOAD.
4. VOICE QUALITY DEGRADATION AND EXCESSIVE BANDWIDTH.

THE MAGNUM SIX has been meticulously engineered to perform superior RF speech processing in accordance with its specifications. As with any high quality, high performance equipment, the MAGNUM SIX is not completely "IDIOT PROOF" and must be properly adjusted to operate with your particular transmitter to obtain the desired increase of average output power.

3.2 FINAL INSTALLATION

- () Refer to Figure 3.2-1 of this manual.
- () Connect the cables that you have installed in your transmitter/transceiver in accordance with Figure 3.2-1.
- () Place the MAGNUM SIX in the location of your choice - on top of or next to your set - and proceed with the instructions contained in the following paragraphs.

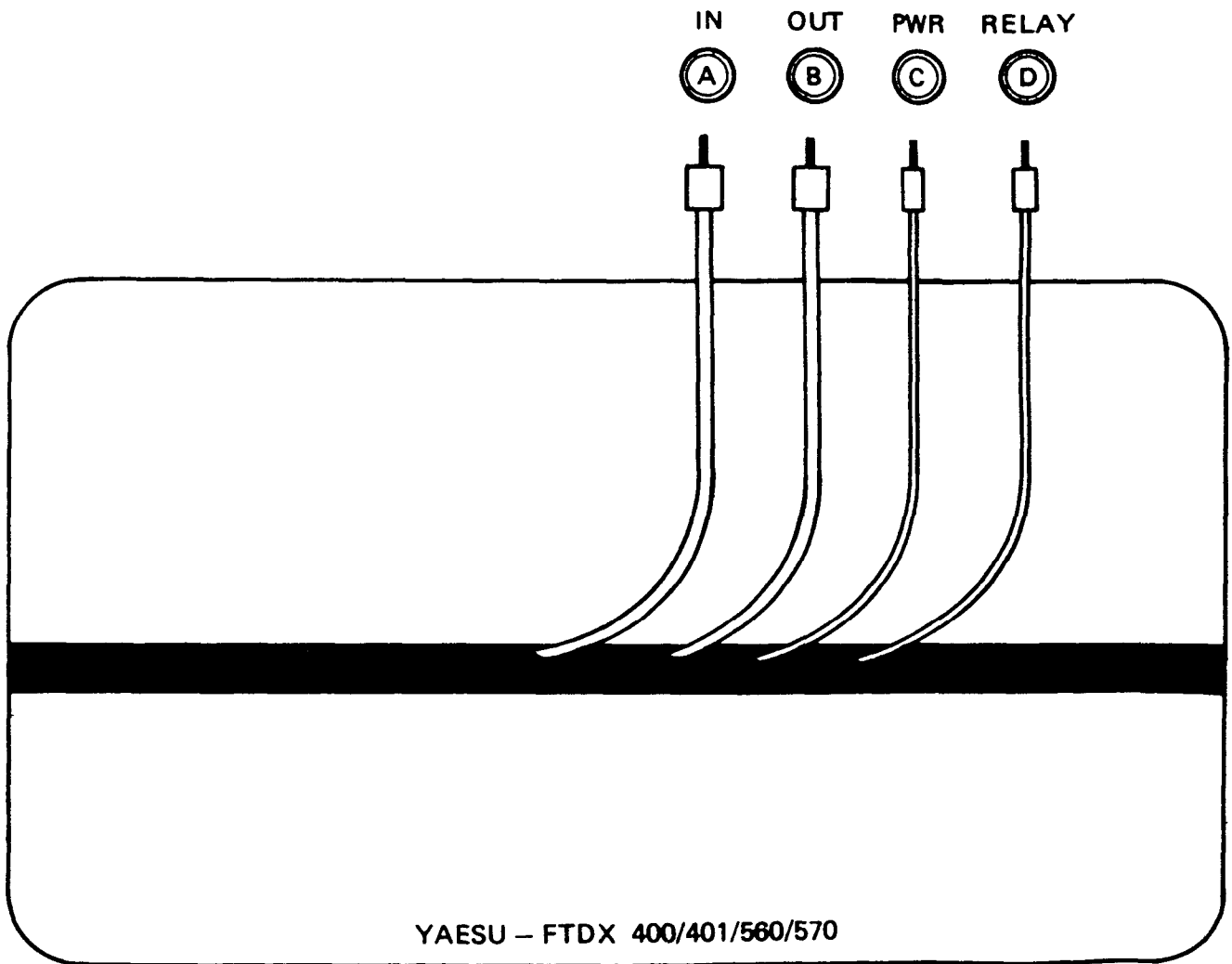
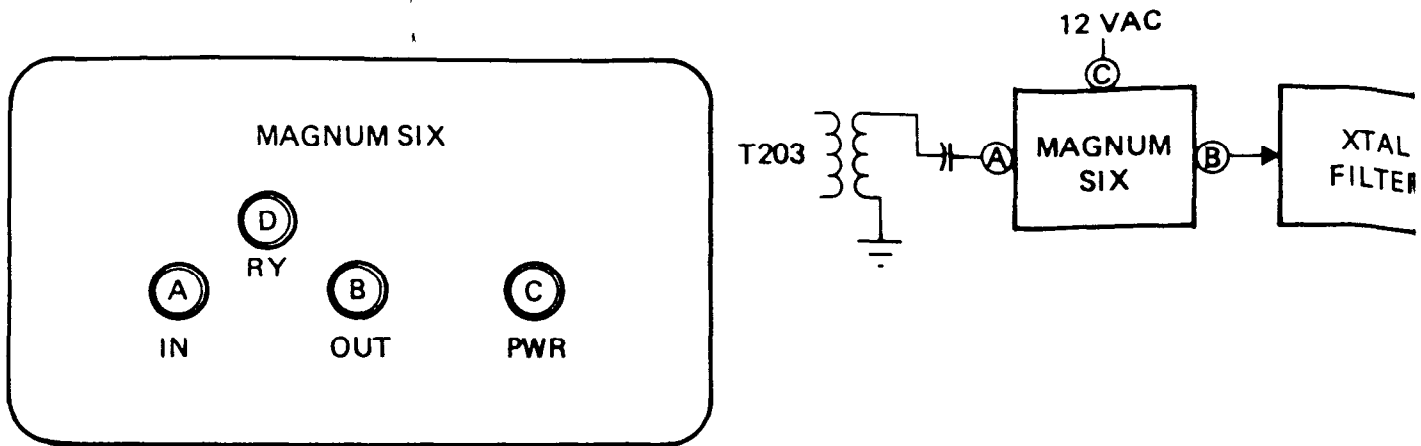

FIGURE 3.2-1

3.3 CALIBRATION, ADJUSTMENT AND OPERATION

To obtain optimum operation of your MAGNUM SIX, it is highly recommended that your station be equipped with a monitor scope or other peak RF voltage output measuring device. Figure 3.3-1 are actual transmitter output patterns photographed while saying the word "FOUR" with the MAGNUM SIX in the OUT (unprocessed) and IN (processed) modes. Use of such measuring equipment, especially if a linear amplifier is employed, will assure that overdrive and subsequent flat-topping and splatter are not generated as a result of your trying to "squeeze out an extra db."

If, however, your station is not equipped with peak RF output monitoring equipment, it is still possible to obtain the added 6 db of clean, average power gain available as a result of the addition of the MAGNUM SIX if you carefully adhere to the following calibration and operating instructions.

3.3.1 ADJUSTMENT AND OPERATION

Prior to the application of power to your equipment and the initiation of the adjustment and calibration procedures, recheck to make sure that your MAGNUM SIX is properly connected in accordance with Figure 3.2-1.

1. Set the MAGNUM SIX's MODE switch to OUT.
2. Set the OUT LEVEL control to the 2 O'clock position.
3. Set your transmitter/transceiver ON and allow time to warm up.
4. Proceed to tune your transmitter/transceiver in accordance with its instruction manual.
5. Set the MIC GAIN to position 10, the MODE switch to CW/TUNE and VOX GAIN to MOX (ten seconds maximum). Adjust the

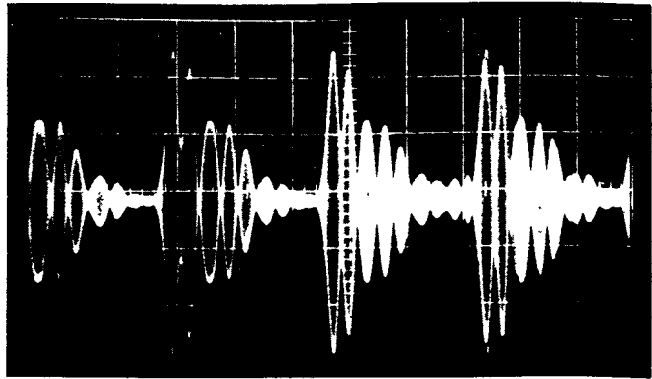

UNPROCESSED SIGNAL OUTPUT

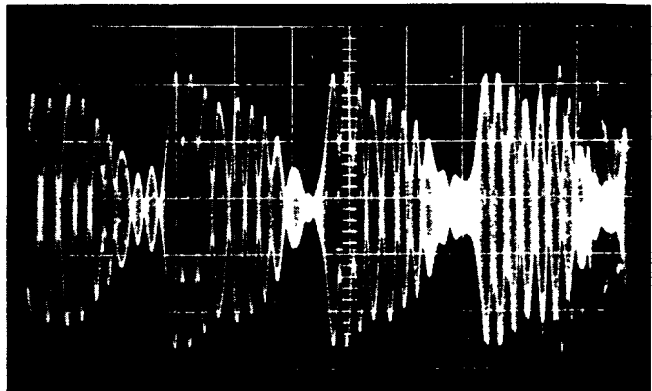

PROCESSED SIGNAL OUTPUT

FIGURE 3.3-1 RF OUTPUT PATTERNS

MAGNUM SIX OUT LEVEL until the meter (IC position) reads the same as before the modification was made (record this MAGNUM SIX setting).

6. Set the MIC GAIN control (during normal operation) as noted in your YAESU manual. Note the ALC reading on the meter while saying "FOUR", set the MAGNUM SIX MODE switch to IN while saying "FOUR", adjust the MAGNUM SIX IN LEVEL until the ALC reading is the same as noted previously (MODE SWITCH OUT position).
7. If you have a monitor scope, the pattern should be similar to the PROCESSED SIGNAL OUTPUT of Figure 3.3-1 when the scope is synched to your voice. Again note that the peaks are sharp and clean. When the LEVEL controls of the MAGNUM SIX are properly adjusted, the amplitude of the highest peaks will be the same for both the OUT and IN MODES.

3.3.2 CALIBRATION

To provide for ease in bandswitching, a calibration chart, Figure 3.3.2-1 has been provided so that the LEVEL CONTROL settings for each band that you use may be recorded. Through use of these data, future operation of your equipment will be quick, clean, more powerful and easily repeatable.

Repeat the steps of paragraph 3.3.1 for each frequency of interest and record the LEVEL CONTROL settings in Figure 3.3.2-1, while setting the MIC GAIN as recorded before the modification.

To complete your addition of the MAGNUM SIX and to assure a signal quality that is the "NE PLUS ULTRA" that can be achieved with existing

FREQUENCY MHZ	PLATE CURRENT MA	MIC GAIN CONTROL POSITION	MAGNUM SIX	
			"OUT" CONTROL POSITION	"IN" CONTROL POSITION
3.900				
7.250				
14.275				
21.350				
28.600				
29.100				
29.600				

FIGURE 3.3.2-1 CALIBRATION CHART

technology, it is recommended that the balanced modular output transformer (and other transformers between the balanced modulator and the MAGNUM SIX if your set is so configured) be re-peaked and that the balanced modulator be re-nulled to account for the lengths of coaxial cable that have been added to your equipment.

3.4 ADDITIONAL AVERAGE POWER

Some additional average power gain can be achieved by increasing the RF clipping action of the MAGNUM SIX. This added gain can be accomplished by advancing the MIC GAIN level control (do not attempt to attain this added power by advancing the MAGNUM SIX's IN LEVEL control) beyond the setting noted in your chart. However, if this option is exercised, you should be aware of the following precautions:

1. Background noise level will increase at some advanced MIC GAIN setting and it will tend to defeat your purpose.
2. Overdrive and flat-topping of your exciter and/or your linear may occur with possible decrease in life of the output tubes.
3. At some point, audio distortion will become apparent and the signal may become broad.

3.5 OPERATING CONSIDERATIONS

The addition of the MAGNUM SIX to your equipment causes your exciter and linear amplifier to work harder and with an increased duty cycle. This added work causes considerably more heat to be generated by your equipment and it is essential that ADEQUATE VENTILATION be provided. NEVER place anything on top of your equipment that will restrict air flow.

In cases where linear amplifiers are not equipped with a fan or blower, the addition of one should be considered. As an added precaution, you may desire to provide a fan or blower to circulate air through the final of your exciter; however, experience has shown that if your equipment is operated within the limits listed in your tune-up chart, no apparent equipment life degradation will occur.

3.6 OPERATION WITH CLASS AB LINEARS

If your station is equipped with a Class AB₁ or AB₂ Linear Amplifier, you may find that excessive grid current may be indicated when the MAGNUM SIX is adjusted in accordance with your chart. If this condition occurs, back-off the IN LEVEL and OUT LEVEL controls of your MAGNUM SIX to regain proper operation of your amplifier. FAILURE TO OBSERVE THIS REQUIREMENT MAY SHORTEN TUBE LIFE AND/OR CAUSE FLAT-TOPPING WITH ATTENDANT SPLATTER. Please refer to Figure 3.3-1 for correct output patterns.

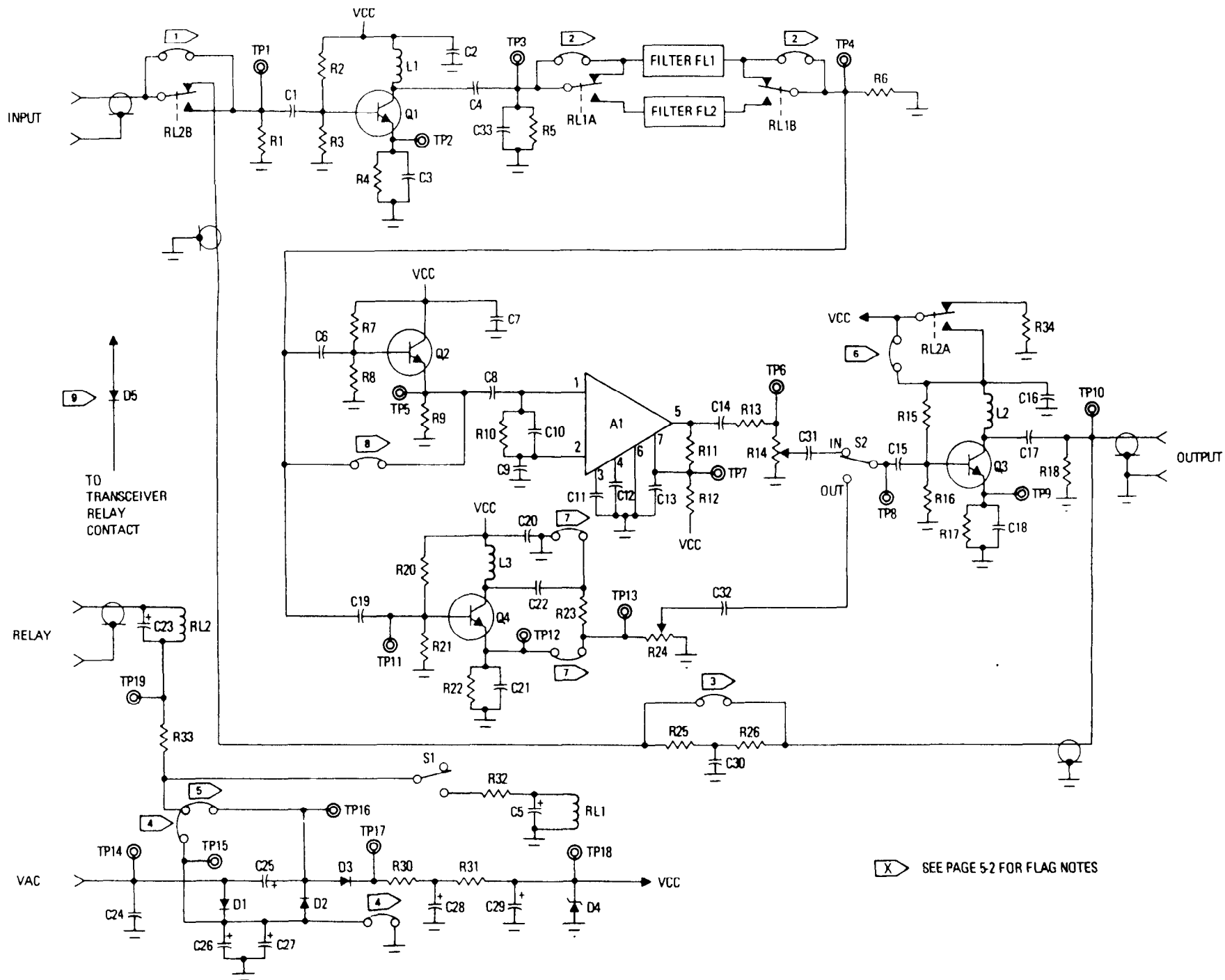

PARTS LIST FOR MAGNUM SIX MODELS USED WITH

DRAKE TRANSMITTERS AND TRANSCEIVERS

PART NUMBER	MODEL		PART NUMBER	MODEL	
	RF6DB-D5S	RF6DB-D9S		RF6DB-D5S	RF6DB-D9S
A1	U10201	U10201	R1	510	-
C1	0.001	0.001	2	-	20K
2	0.01	0.01	3	220K	1.5K
3	0.01	-	4	750	100
4	0.001	0.001	5	510	510
5	500	500	6	510	-
6	0.001	0.01	7	-	-
7	0.01	0.01	8	360K	360K
8	0.001	0.001	9	2.4K	2.4K
9	0.1	0.1	10	250	250
10	0.001	0.005	11	1.5K	1.5K
11	0.1	0.1	12	select	select
12	0.1	0.1	13	-	-
13	0.1	0.1	14	25K	25K
14	0.001	0.001	15	-	10K
15	0.001	0.001	16	100K	1.5K
16	0.01	0.01	17	750	100
17	0.001	0.01	18	-	510
18	0.01	-	19	-	-
19	0.001	0.01	20	-	-
20	0.01	0.01	21	470K	470K
21	0.01	0.01	22	2K	2K
22	0.01	0.01	23	3.9K	-
23	-	500	24	2.5K	2.5K
24	0.01	0.01	25	-	-
25	500	500	26	-	-
26	-	-	30	100,1W	27
27	-	-	31	200,1W	200,2W
28	500	500	32	100,2W	100,1W
29	500	500	33	-	100,2W
30	-	-	34	-	100,1W
31	short	short	35	-	-
32	short	short	RL1	R10-E1-Z2-V52	R10-E1-Z2-V52
33	-	-	2	-	R10-E1-Z2-V52
D1	-	-	S1	MST105D	MST105D
2	1N4001	1N4001	2	399190-23	399190-23
3	1N4001	1N4001	L1	470	470
4	1N963B	1N963B	2	470	470
5	-	-	3	270	270
FL1	5.645-2.4U	9.0-2.1U			
2	5.645-2.4L	9.0-2.1L			
Q1	2N5248	2N4995			
2	2N5248	2N5248			
3	2N5248	2N4995			
4	2N5248	2N5248			

UNLESS OTHERWISE SPECIFIED
 ALL RESISTORS ARE IN OHMS,
 1/4 WATT, $\pm 5\%$
 ALL CAPACITORS ARE IN MICROFARADS
 ALL COILS ARE IN MICROHENRIES

5.0 TROUBLE SHOOTING AND SERVICE

As a result of our solid state design, extensive pre-production development testing, and pre-delivery burn-in and test, the MAGNUM SIX should deliver years of trouble-free operation. In the event a malfunction occurs, the following checks should be made:

1. Check all interconnect cables for continuity and/or shorts.
2. With power applied, measure the ac voltage to ground at the 12 volt ac phono socket at the rear of the MAGNUM SIX to determine that 12 volts ac is available from the exciter.
3. Measure the dc voltage at the Vcc on board 104, to verify that a dc voltage of approximately 12 volts is available.
4. Using an 11 megohm VTVM with RF probe or an oscilloscope, probe the PROCESSOR IN phono socket to determine if an RF voltage of 150 to 200 mv is available when the exciter is in the KEY-DOWN or TUNE condition and MIC GAIN control fully clockwise.
5. Using the VTVM or oscilloscope, measure the PROCESSOR OUT phono socket of the MAGNUM SIX for an RF voltage of 150 to 200 mv with the MAGNUM SIX in both the IN and OUT MODE and with both LEVEL controls advanced fully clockwise and the transmitter in the KEY-DOWN or TUNE condition per test 4.
6. If all of the above checks have been performed and the malfunction has not been isolated, and you believe that the problem is with the MAGNUM SIX, write to our staff describing the symptoms and forward all data pertaining to the above trouble shooting procedures. We will evaluate your findings and either advise you of further tests to perform or send you instructions for returning the MAGNUM SIX to our plant. If the unit is within the warranty period and the unit has in our opinion not been altered or maltreated, the unit will be repaired or replaced

FLAGG NOTE	DRAKE T4X	DRAKE TR4	COLLINS 32S KWM	HEATH HW100 SB100	HEATH SB400	KENWOOD T-599 TS511	YAESU FT101	YAESU FTdx 400/401 560/570
1	OPEN	SHORT	OPEN	OPEN	OPEN	OPEN	OPEN	SHORT
2	SHORT	SHORT	OPEN	OPEN	OPEN	OPEN	OPEN	OPEN
3	SHORT	SHORT	OPEN	SHORT	SHORT	SHORT	SHORT	SHORT
4	OPEN	OPEN	OPEN	OPEN	OPEN	OPEN	OPEN	SHORT
5	OPEN	SHORT	OPEN	OPEN	OPEN	OPEN	OPEN	OPEN
6	SHORT	OPEN	SHORT	SHORT	SHORT	SHORT	SHORT	OPEN
7	OPEN	OPEN	SHORT	SHORT	SHORT	OPEN	OPEN	OPEN
8	OPEN	OPEN	SHORT	OPEN	OPEN	OPEN	OPEN	OPEN
9	Diode is provided in "Relay" lead of Cable Assy. of FTdx models. Cathode end goes to relay contact of YAESU set.							

at our discretion . If the unit is beyond the warranty period , we will provide free trouble shooting and will advise you of the repair costs prior to performing the repair .