

HEATHKIT[®] MANUAL

for the

MICROLIZER
Model HD-1986

595-3187



HEATH COMPANY • BENTON HARBOR, MICHIGAN

HEATH COMPANY PHONE DIRECTORY

The following telephone numbers are direct lines to the departments listed:

Kit orders and delivery information (616) 982-3411
Credit (616) 982-3561
Replacement Parts (616) 982-3571

Technical Assistance Phone Numbers

8:00 A.M. to 12 P.M. and 1:00 P.M. to 4:30 P.M., EST, Weekdays Only
R/C, Audio, and Electronic Organs (616) 982-3310
Amateur Radio (616) 982-3296
Test Equipment, Weather Instruments and
Home Clocks (616) 982-3315
Television (616) 982-3307
Aircraft, Marine, Security, Scanners, Automotive,
Appliances and General Products (616) 982-3496
Computers — Hardware (616) 982-3309
Computers — Software:
Operating Systems, Languages, Utilities (616) 982-3860
Application Programs (616) 982-3884
Heath Craft Wood Works (616) 982-3423



YOUR HEATHKIT 90-DAY LIMITED WARRANTY

Consumer Protection Plan for Heathkit Consumer Products

Welcome to the Heath family. We believe you will enjoy assembling your kit and will be pleased with its performance. Please read this Consumer Protection Plan carefully. It is a "LIMITED WARRANTY" as defined in the U.S. Consumer Product Warranty and Federal Trade Commission Improvement Act. This warranty gives you specific legal rights, and you may also have other rights which vary from state to state.

Heath's Responsibility

PARTS — Replacements for factory defective parts will be supplied free for 90 days from date of purchase. Replacement parts are warranted for the remaining portion of the original warranty period. You can obtain warranty parts direct from Heath Company by writing or telephoning us at (616) 982-3571. And we will pay shipping charges to get those parts to you . . . anywhere in the world.

SERVICE LABOR — For a period of 90 days from the date of purchase, any malfunction caused by defective parts or error in design will be corrected at no charge to you. You must deliver the unit at your expense to the Heath factory, any Heathkit Electronic Center (units of Veritechnology Electronics Corporation), or any of our authorized overseas distributors.

TECHNICAL CONSULTATION — You will receive free consultation on any problem you might encounter in the assembly or use of your Heathkit product. Just drop us a line or give us a call. Sorry, we cannot accept collect calls.

NOT COVERED — The correction of assembly errors, adjustments, calibration, and damage due to misuse, abuse, or negligence are not covered by the warranty. Use of corrosive solder and/or the unauthorized modification of the product or of any furnished component, will void this warranty in its entirety. This warranty does not include reimbursement for inconvenience, loss of use, customer assembly, set-up time, or unauthorized service.

This warranty covers only Heath products and is not extended to other equipment or components that a customer uses in conjunction with our products.

SUCH REPAIR AND REPLACEMENT SHALL BE THE SOLE REMEDY OF THE CUSTOMER AND THERE SHALL BE NO LIABILITY ON THE PART OF HEATH FOR ANY SPECIAL, INDIRECT, INCIDENTAL OR CONSEQUENTIAL DAMAGES, INCLUDING BUT NOT LIMITED TO ANY LOSS OF BUSINESS OR PROFITS, WHETHER OR NOT FORSEEABLE.

Some states do not allow the exclusion or limitation of incidental or consequential damages, so the above limitation or exclusion may not apply to you.

Owner's Responsibility

EFFECTIVE WARRANTY DATE — Warranty begins on the date of first consumer purchase. You must supply a copy of your proof of purchase when you request warranty service or parts.

ASSEMBLY — Before seeking warranty service, you should complete the assembly by carefully following the manual instructions. Heathkit service agencies cannot complete assembly and adjustments that are customer's responsibility.

ACCESSORY EQUIPMENT — Performance malfunctions involving other non-Heath accessory equipment, (antennas, audio components, computer peripherals and software, etc.) are not covered by this warranty and are the owner's responsibility.

SHIPPING UNITS — Follow the packing instructions published in the assembly manuals. Damage due to inadequate packing cannot be repaired under warranty.

If you are not satisfied with our service (warranty or otherwise) or our products, write directly to our Director of Customer Service, Heath Company, Benton Harbor MI 49022. He will make certain your problems receive immediate, personal attention.

Heathkit® Manual

for the

MICROLIZER Model HD-1986

595-3187

TABLE OF CONTENTS

Introduction	2	Specifications	28
Assembly Notes	3	Circuit Description	29
Parts List	7	Semiconductor Identification Charts	30
Step-By-Step Assembly	10	Circuit Board X-Ray View	31
Initial Tests	23	Schematic Diagram .. Illustration Booklet, Page 5.	
Operation	25	Warranty	Inside front cover
In Case Of Difficulty	26	Customer Service	Inside rear cover
Troubleshooting Chart	27		

INTRODUCTION

The Heathkit Model HD-1986 Microlizer is a microphone equalizer for amateur transceivers. Its variable low and high response and audio gain capabilities will let you tailor the input signal to your transmitter audio stages, giving you clearer, crisper transmitted audio by compensating for your microphone and your voice characteristics. The unit is battery-operated and even has an automatic battery test circuit; if the front panel LED comes on momentarily when you first turn the Microlizer on,

your battery is OK. With this unit, you will attain maximum output on SSB, with a clearer sounding signal.

You will have to prepare a cable to connect between your Transceiver and the Microlizer. These parts are not supplied and will have to be purchased. You will need a stereo 2-conductor phone plug, a microphone connector, and a 2-conductor with ground cable.

ASSEMBLY NOTES

TOOLS

You will need these tools to assemble your kit.

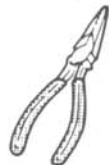
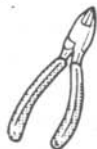
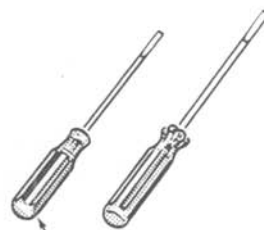

PLIERS

LONG-NOSE
PLIERSDIAGONAL
CUTTERSWIRE
STRIPPERS1/8" & 1/4"-BLADE
SCREWDRIVERSPHILLIPS
SCREWDRIVER

OTHER HELPFUL TOOLS

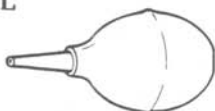
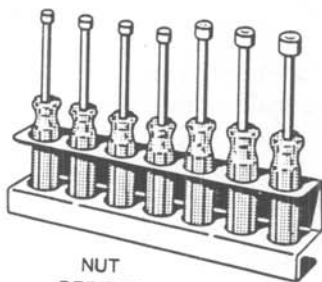
NUT STARTER
(May Be Supplied
With Kit)DESOLDERING
BULB*DESOLDERING
BRAID*NUT
DRIVERSPENCIL
SOLDERING IRON
(22 to 25 WATTS)

*To Remove Solder From Circuit Connections.

ASSEMBLY

1. Follow the instructions carefully. Read the entire step before you perform each operation.
2. The illustrations in the Manual are called Pictorials and Details. Pictorials show the overall operation for a group of assembly steps; Details generally illustrate a single step. When you are directed to refer to a certain Pictorial "for the following steps," continue using that Pictorial until you are referred to another Pictorial for another group of steps.
3. Most kits use a separate "Illustration Booklet" that contains illustrations (Pictorials, Details, etc.) that are too large for the Assembly Manual. Keep the "Illustration Booklet" with the Assembly Manual. The illustrations in it are arranged in Pictorial number sequence.
4. Position all parts as shown in the Pictorials.
5. Solder a part or a group of parts only when you are instructed to do so.

6. Each circuit part in an electronic kit has its own component number (R2, C4, etc.). Use these numbers when you want to identify the same part in the various sections of the Manual. These numbers, which are especially useful if a part has to be replaced, appear:
- In the Parts List,
 - At the beginning of each step where a component is installed,
 - In some illustrations,
 - In Troubleshooting Charts,
 - In the Schematic,
 - In the sections at the rear of the Manual.
7. When you are instructed to cut something to a particular length, use the scales (rulers) provided at the bottom of the Manual pages.

SAFETY WARNING: Avoid eye injury when you cut off excessive lead lengths. Hold the leads so they cannot fly toward your eyes.

SOLDERING

Soldering is one of the most important operations you will perform while assembling your kit. A good solder connection will form an electrical connection between two parts, such as a component lead and a circuit board foil. A bad solder connection could prevent an otherwise well-assembled kit from operating properly.

It is easy to make a good solder connection if you follow a few simple rules:

1. Use the right type of soldering iron. A 22 to 25-watt pencil soldering iron with a 1/8" or 3/16" chisel or pyramid tip works best.
2. Keep the soldering iron tip clean. Wipe it often on a wet sponge or cloth; then apply solder to the tip to give the entire tip a wet look. This process is called tinning, and it will protect the tip and enable you to make good connections. When solder tends to "ball" or does not stick to the tip, the tip needs to be cleaned and retinned.

NOTE: Always use rosin core, radio-type solder (60:40 tin-lead content) for all of the soldering in this kit. This is the type we have supplied with the parts. The Warranty will be void and we will not service any kit in which acid core solder or paste has been used.

Heathkit®

PARTS

Resistors are identified in Parts Lists and steps by their resistance value in Ω (ohms), $k\Omega$ (kilohms), or $M\Omega$ (megohms). They are usually identified by a color code and four or five color bands, where each color represents a number. These colors (except for the last band, which indicates a resistor's "tolerance") will be given in the steps in their proper order. Therefore, the following color code is given for information only. NOTE: Occasionally, a "precision" or "power" resistor may have the value stamped on it.

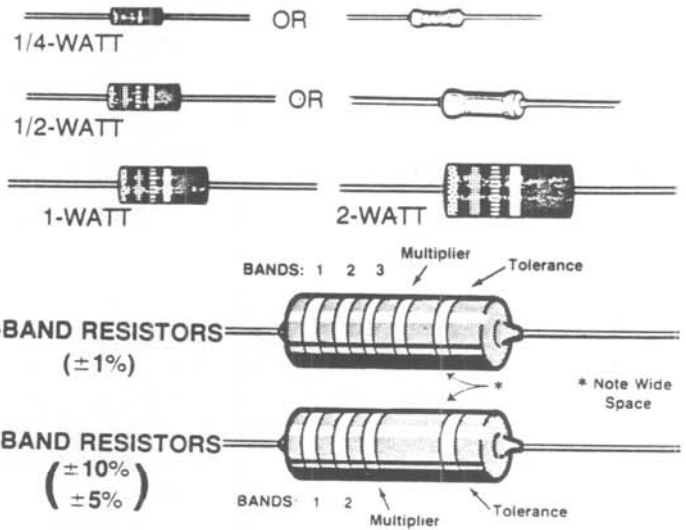

Band 1 1st Digit		Band 2 2nd Digit		Band 3 (if used) 3rd Digit		Multiplier		Resistance Tolerance	
Color	Digit	Color	Digit	Color	Digit	Color	Multiplier	Color	Tolerance
Black	0	Black	0	Black	0	Black	1	Silver	= 10%
Brown	1	Brown	1	Brown	1	Brown	10	Gold	= 5%
Red	2	Red	2	Red	2	Red	100	Red	= 2%
Orange	3	Orange	3	Orange	3	Orange	1,000	Brown	= 1%
Yellow	4	Yellow	4	Yellow	4	Yellow	10,000	Green	= 5%
Green	5	Green	5	Green	5	Green	100,000	Blue	= 25%
Blue	6	Blue	6	Blue	6	Blue	1,000,000	Violet	= .1%
Violet	7	Violet	7	Violet	7	Silver	0.01	Gray	= .05%
Gray	8	Gray	8	Gray	8	Gold	0.1		
White	9	White	9	White	9				

Capacitors will be called out by their capacitance value in μF (microfarads) or pF (picofarads) and type: ceramic, Mylar*, electrolytic, etc. Some capacitors may have their value printed in the following manner:

EXAMPLES:

$$151K = 15 \times 10 = 150 \text{ pF}$$

$$759 = 75 \times 0.1 = 7.5 \text{ pF}$$

NOTE: The letter "R" may be used at times to signify a decimal point: as in: 2R2 = 2.2 (pF or μF).

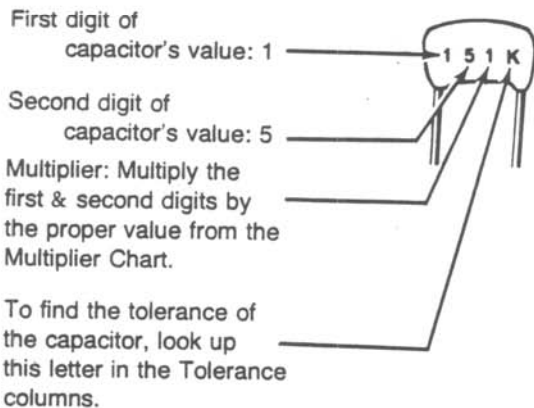

MULTIPLIER		TOLERANCE OF CAPACITOR		
FOR THE NUMBER:	MULTIPLY BY:	10 pF OR LESS	LETTER	OVER 10 pF
0	1	$\pm 0.1 \text{ pF}$	B	
1	10	$\pm 0.25 \text{ pF}$	C	
2	100	$\pm 0.5 \text{ pF}$	D	
3	1000	$\pm 1.0 \text{ pF}$	F	= 1%
4	10,000	$\pm 2.0 \text{ pF}$	G	= 2%
5	100,000		H	= 3%
			J	= 5%
8	0.01		K	= 10%
9	0.1		M	= 20%

*DuPont Registered Trademark.

SPECIAL ASSEMBLY NOTES

NOTE: The following suggestions will not necessarily improve the operation of your kit. They will, however, help you troubleshoot it (if it ever becomes necessary), and help you perform the "Circuit Board Checkout" steps at the end of the assembly sections of this Manual. And you will have a more professionally-built kit when you finish.

1. When you install resistors, always position each resistor so you can read the bands on the resistor in the same direction as you can read the printing on the circuit board (see Figure 1). For resistors that have the value printed on them instead of color bands, install these resistors so the values are facing away from the circuit board and read in the same direction as the printing on the circuit board.

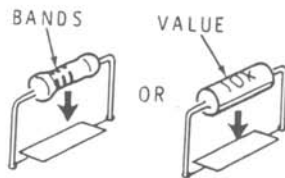

Figure 1

2. When you install ceramic, Mylar, or mica capacitors, always position each capacitor so you can read the value on the capacitor in the same direction as you can read the printing on the circuit board (see Figure 2).

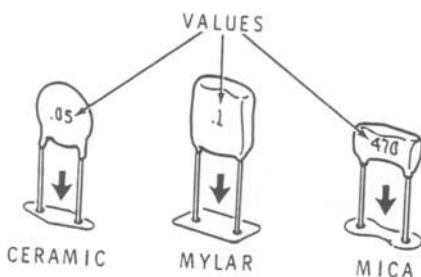

Figure 2

3. When you install electrolytic or other tubular capacitors, always position each capacitor so the value is facing away from the circuit board (see Figure 3). Be sure to observe the correct polarity when you install electrolytic capacitors (as you will be directed in the steps). Other, non-polarized, capacitors should be installed so you can read the values in the same direction as the printing on the circuit board.

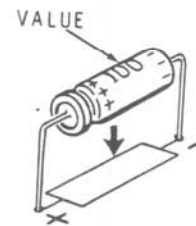

Figure 3

4. Install diodes so the type numbers or part numbers are facing away from the circuit board. Be sure to match the band on one end of each diode with the band mark on the circuit board.

PARTS LIST

Unpack your kit and check each part against the following list. Do not remove any parts from the Taped Components Chart until you use them in a step. Return any part that is packed in an individual envelope, with the part number on it, back to the envelope after you identify it until that part is called for in a step. Do not throw away any packing material until all parts are accounted for.

To order a replacement part, always include the PART NUMBER. Use the Parts Order Form furnished with this kit. If a Parts Order Form is not available, refer to "Replacement Parts" inside the rear cover of this Manual. For prices, refer to the separate "Heath Parts Price List."

TAPED COMPONENTS

Refer directly to the enclosed "Taped Component Chart." Follow the instructions at the top of that chart to check the following components.

HEATH Part No.	QTY.	DESCRIPTION	CIRCUIT Comp. No.
RESISTORS			
NOTE: All resistors are 1/4-watt and have a 5% tolerance (fourth band gold) unless designated otherwise.			
6-470-12	✓ 1	47 Ω (yel-viol-blk)	R24
6-181-12	✓ 1	180 Ω (brn-gry-brn)	R2
6-103-12	✓ 6	10k Ω (brn-blk-org)	R4,R5, R11,R13, R17,R22
6-273-12	✓ 1	27k Ω (red-viol-org)	R25
6-333-12	✓ 1	33k Ω (org-org-org)	R19
6-823-12	✓ 1	82k Ω (gry-red-org)	R1

HEATH Part No.	QTY.	DESCRIPTION	CIRCUIT Comp. No.
Resistors (Cont'd.)			
6-104-12	✓ 8	100k Ω (brn-blk-yel)	R3,R7, R8,R9, R12,R15, R23,R27
6-224-12	✓ 1	220k Ω (red-red-yel)	R16
OTHER COMPONENTS			
21-761	✓ 2	.01 μF (103) glass ceramic capacitor	C3,C8
56-59	✓ 1	1N5230B zener diode	D1

NON-TAPED PARTS

The following parts are not taped on strips. The key numbers correspond to the numbers on the "Parts Pictorial" (Illustration Booklet, Page 1).

KEY No.	HEATH Part No.	QTY.	DESCRIPTION	CIRCUIT Comp. No.	KEY No.	HEATH Part No.	QTY.	DESCRIPTION	CIRCUIT Comp. No.
CAPACITORS					CONNECTORS – SOCKETS – CONTROLS – SWITCH				
A1	21-172	1	100 pF ceramic	C15	D1	432-866	3	Spring connector (one extra)	
A1	21-17	3	270 pF ceramic	C2,C4, C15	D2	432-1030	1	2-hole socket shell	
A1	21-140	1	.001 (10M) ceramic	C7	D3	434-230	2	8-pin IC socket	
A2	27-161	1	.01 μ F Mylar	C9	D4	436-27	1	Phone jack	J2
A2	27-137	1	.02 μ F Mylar	C11	D5	432-1099	1	Microphone jack	J1
A3	29-4	1	2000 pF polyester	C12	D6	10-1218	1	100 k Ω control	R6
A4	25-859	2	.47 μ F electrolytic	C6,C13	D6	10-1219	2	1 M Ω control	R14,R15
A4	25-924	1	2.2 μ F electrolytic	C1	D7	64-920	1	Pushbutton switch	SW1
A4	25-879	1	4.7 μ F electrolytic	C14					
DIODE					HARDWARE				
B1	412-633	1	Light-emitting diode (LED)	D2	Hardware packets are marked to show the size of the hardware they contain (HDW #3, HDW #4, HDW #6) etc.). You may have to open more than one packet, to locate all of the hardware.				
TRANSISTORS – INTEGRATED CIRCUITS (IC's)					#3 Hardware				
NOTE: Transistors and integrated circuits are marked for identification in one of the following ways:					E1	250-49	2	3-48 \times 1/4" screw	
1.	Part number.				E2	254-7	2	#3 lockwasher	
2.	Type number. (On integrated circuits, use only those numbers and letters in BOLD print. Disregard any other numbers or letters.)				E3	252-1	2	3-48 nut	
3.	Part number and type number.				#4 Hardware				
4.	Part number with a type number other than the one listed.				E4	250-366	8	4-40 \times 3/16" screw	
C1	417-801	1	MPSA20 transistor	Q1	E5	254-9	4	#4 lockwasher	
C2	442-728	2	LM2904 IC	U1,U2	E6	255-798	4	4-40 spacer	
					#6 Hardware				
					E7	250-33	3	6-32 \times 1/8" setscrew	
					E8	250-1307	4	#6 \times 1/4" sheet metal screw	

Heathkit®

KEY HEATH QTY. DESCRIPTION
 No. Part No. _____

Other Hardware

E9	252-7	1	Control Nut
E10	253-10	1	Control flat washer
E11	254-5	1	Control lockwasher
E12	259-34	3	Control solder lug

MISCELLANEOUS

F1	475-10	6	Ferrite bead
F2	455-44	3	Bearing
F3	462-1138	1	Switch knob
F4	462-1157	3	Control knob
F5	261-29	4	Foot
F6	208-42	1	Battery holder

KEY HEATH QTY. DESCRIPTION
 No. Part No. _____

F7	432-798	1	Battery connector
F8	75-743	1	Insulator
	344-50	5"	Black wire
	344-59	10"	White wire
	340-8	11"	Bare wire
	343-12	18"	Shielded cable
	85-2943-2	1	Circuit board
F9	90-1327-1	1	Cover
F10	90-1471-1	1	Chassis
	800-1471-1	1	Blue and white label
	597-260	1	Parts Order Form
		1	Taped Components Chart
		1	Assembly Manual (See Page 1 for the part number.)
			Solder

You will need one 9-volt transistor battery, NEDA #1604. Representative manufacturers and their type numbers for the 9-volt batteries are:

- Eveready #216, PP3
- Burgess #2U6
- Mallory #TR-146X (long life)
- RCA #VS323
- Hellesens #410
- Varta #438
- CEI #6F22



STEP-BY-STEP ASSEMBLY

CIRCUIT BOARD ASSEMBLY

Refer to Pictorial 1-1 (Illustration Booklet, Page 2) as you read the following notes and steps.

NOTES:

1. Many circuit board drawings, such as the one shown in Pictorial 1-1, are divided into two or more sections. These sections show you which area of the circuit board you are working in for a specific series of steps.
2. Each series of steps has you installing parts in a top-to-bottom, left-to-right sequence. Occasionally, you may be directed to install a particular component in an area out of sequence. These components are each identified in the step and on the Pictorial with a special callout.
3. Check off each step as you perform it. You may also wish to place a check mark near each component on the Pictorial as you install it.
4. In general, solder instructions are given only at the end of a series of similar steps. You may solder more often, if you desire.

NOTE: Refer to the "Taped Component Chart" before you begin.

In the following steps, you will be given detailed instructions on how to install and solder the first part on the circuit board. Read and perform each step carefully. Then use the same procedure whenever you install parts on a circuit board.

- () Note that one side of the circuit board has the component outline shown on it. This side of the circuit board is referred to as the "component side."

- () Position the circuit board as shown in the Pictorial with the component side up. Always install components on the component side of the circuit board, and solder the leads to the foil on the other side unless a step specifically directs you otherwise.

- () R7: Hold a 100 k Ω (brn-blk-yel) resistor as shown and bend the leads straight down with long-nose pliers to fit the hole spacing on the circuit board.

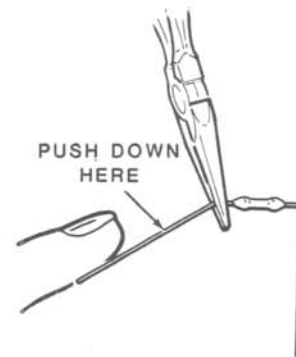

- () Start the leads into the holes at the resistor's location at the top of Section 1 of the circuit board. The end with color bands may be positioned either way. NOTE: Resistors are identified by the following outline:



- () Press the resistor against the circuit board. Then bend the leads outward slightly to hold it in place.



(/) Solder the resistor leads to the circuit board as follows:

1. Push the soldering iron tip against both the lead and the circuit board foil. Heat **both** for two or three seconds.

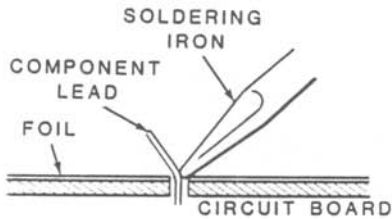

2. Then apply solder to the other side of the connection. **IMPORTANT:** Let the heated lead and the circuit board foil melt the solder.

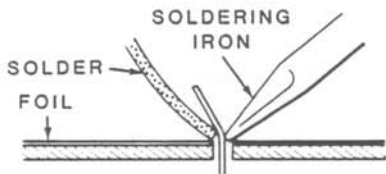

3. As the solder begins to melt, allow it to flow around the connection. Then remove the solder and the iron and let the connection cool.

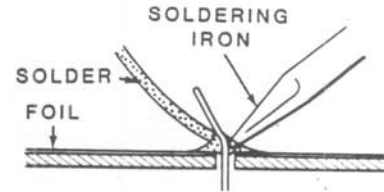

- (/) Cut off the excess lead lengths close to the connection. **WARNING:** Clip the leads so the ends will not fly toward your eyes.
- (/) Check each connection. Compare it to the illustrations on Page 12. After you have checked the solder connections, proceed with the assembly on Page 13. Use the same soldering procedure for each connection.

A GOOD SOLDER CONNECTION

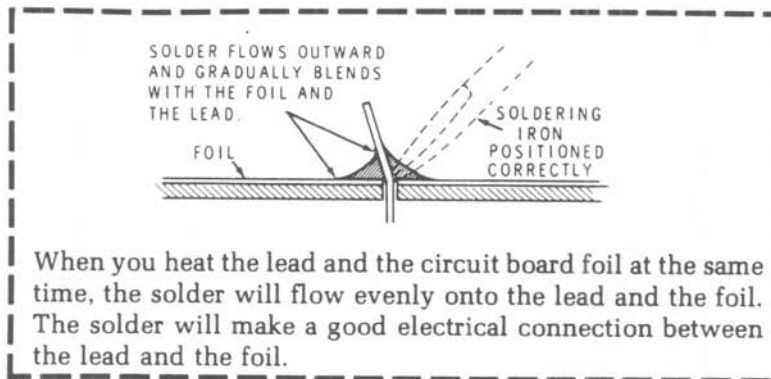

POOR SOLDER CONNECTIONS

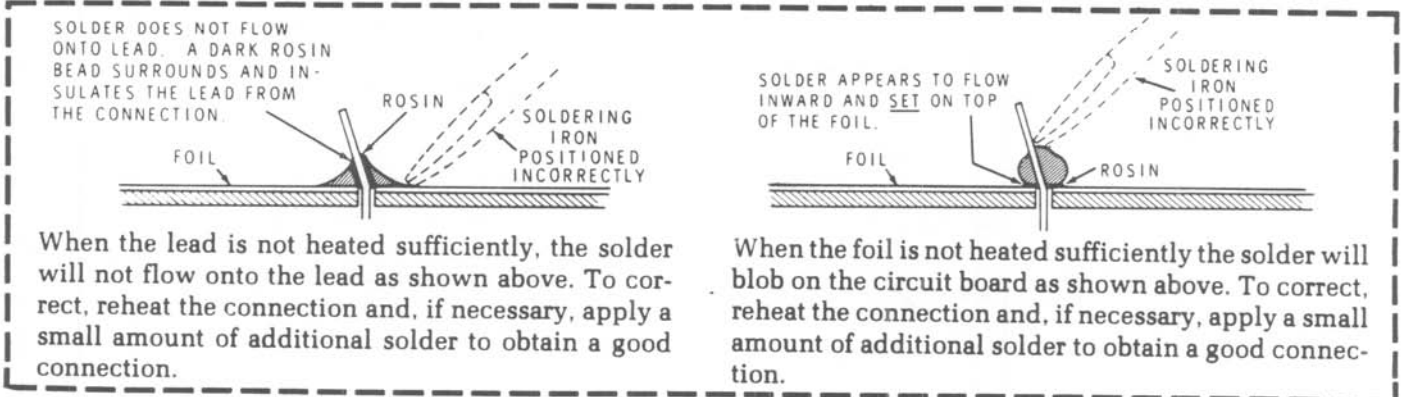

SOLDER BRIDGES

A solder bridge between two adjacent foils is shown in photograph A. Photograph B shows how the connection should appear. A solder bridge may occur if you accidentally touch an adjacent previously soldered connection, if you use too much solder, or if you "drag" the soldering iron across other foils as you remove it from the connection. A good rule to follow is: always take a good look at the foil area around each lead before you solder it. Then, when you solder the connection, make sure the solder remains in this area and does not bridge to another foil. This is especially important when the foils are small and close together. NOTE: It is alright for solder to bridge two connections on the same foil.

Use only enough solder to make a good connection, and lift the soldering iron straight up from the circuit board. If a solder bridge should develop, turn the circuit board foil-side-down and heat the solder between connections. The excess solder will run onto the tip of the soldering iron, and this will remove the solder bridge. NOTE: The foil side of most circuit boards has a coating on it called "solder resist." This is a protective insulation to help prevent solder bridges.

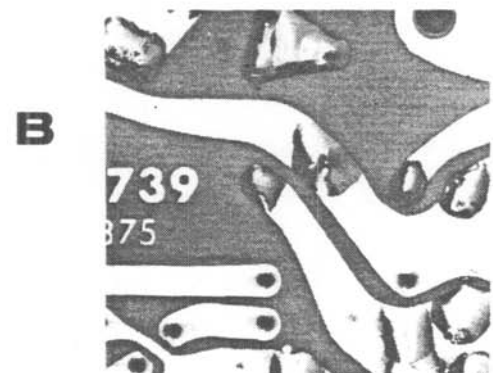
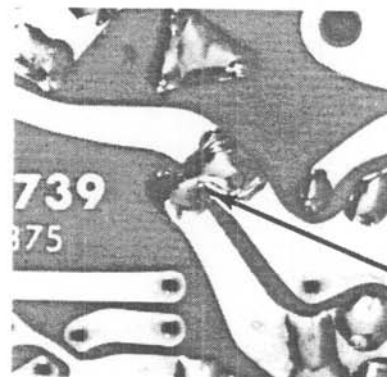

Heathkit®

Start at the top of Section 1 and install the following components. The sequence of the steps matches the locations of the components on the circuit board.
NOTE: Make sure you installed resistor R7 in an earlier step.

- (✓) C3: .01 uF (103) glass ceramic. NOTE: These capacitors are identified on the board by the following outline.



- (✓) FB: Install two ferrite beads on a 1-1/4" bare wire as shown.

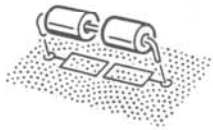

- (✓) R1: 82 kΩ (gry-red-org).

NOTE: When you install a diode, match the banded end of the diode with the band mark on the circuit board. A diode will not work properly if it is installed backwards.

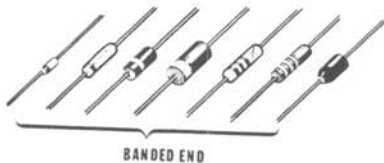

- (✓) D1: 1N5230B zener diode (#56-59). NOTE: This diode is identified on the board by the following outline.



- (✓) R2: 180 Ω (brn-gry-brn).
(✓) Solder the leads to the foil and cut off the excess lead lengths.

Install components in Section 2 of the circuit board as follows:

- (✓) R3: 100 kΩ (brn-blk-yel).
(✓) R5: 10 kΩ (brn-blk-org).
(✓) C8: .01 uF (103) glass ceramic.
(✓) R23: 100 kΩ (brn-blk-yel).
(✓) R27: 100 kΩ (brn-blk-yel).
(✓) R9: 100 kΩ (brn-blk-yel).
(✓) R4: 10 kΩ (brn-blk-org).
(✓) R12: 100 kΩ (brn-blk-yel).
(✓) R8: 100 kΩ (brn-blk-yel).
(✓) R13: 10 kΩ (brn-blk-org).
(✓) R11: 10 kΩ (brn-blk-org).
(✓) FB: Install two ferrite beads on a 1-1/4" bare wire.
(✓) Solder the leads to the foil and cut off the excess lead lengths.

Install components in Section 3 of the circuit board as follows:

- (✓) R24: 47 Ω (yel-viol-blk).
(✓) R25: 27 kΩ (red-viol-org).
(✓) R22: 10 kΩ (brn-blk-org).
(✓) W1: 3/4" bare wire.
(✓) W2: 1" bare wire.
(✓) R16: 220 kΩ (red-red-yel).
(✓) R19: 33 kΩ (org-org-org).
(✓) R15: 100 kΩ (brn-blk-yel).
(✓) R17: 10 kΩ (brn-blk-org).
(✓) Solder the leads to the foil and cut off the excess lead lengths.



Refer to Pictorial 1-2 (Illustration Booklet, Page 2) for the following steps.

NOTES:

1. To install an IC socket, make sure the pins are straight. Then start the pins into the circuit board holes. The index mark on the circuit board must still be visible after you install the socket. Solder the pins to the foil as you install each socket.

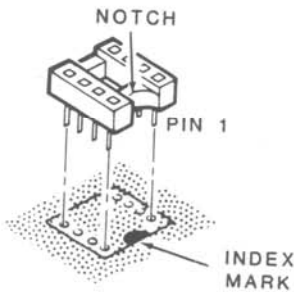

2. It is very easy to form a solder bridge between foils when you install an IC socket. After you install each socket, carefully inspect the foil for solder bridges and remove any that you find as described below. If you suspect that you have a solder bridge but are not positive, you can check your foil pattern against the one shown on Page 31.

To remove a solder bridge, hold the circuit board component-side up as shown and hold your soldering iron tip between the two points that are bridged. The solder will flow down the soldering iron tip.

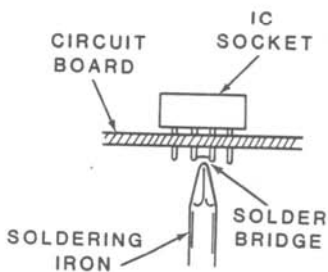

Install IC sockets on the circuit board at the following locations. NOTE: IC sockets are identified on the circuit board by the following outline:

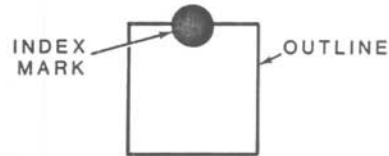

- (✓) Two 8-pin IC sockets at U1 and U2.
- () U1,U2: Install LM2904 IC's (#442-728) in their sockets using the following procedure.

The pins on the IC's may be bent out at an angle so they do not line up with the holes in the IC socket. DO NOT try to install an IC without first bending the pins as described below. To do so may damage the IC pins or the socket, causing intermittent contact.



Before you install an IC, lay it down on its side as shown below and very carefully roll it toward the pins to bend the lower pins into line. Then turn the IC over and bend the pins on the other side in the same manner.



Compare the IC to the drawing shown below. Then determine which end of the IC is the pin 1 end.

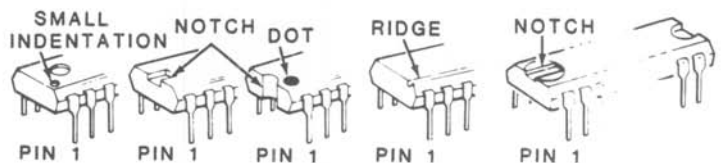

Heathkit®

Position the pin 1 end of the IC over the index mark on the circuit board. Then, making sure that all of the pins are started into the holes, push the IC firmly into the socket. NOTE: An IC pin can become bent under the IC and it will appear as though it is correctly installed in the socket.

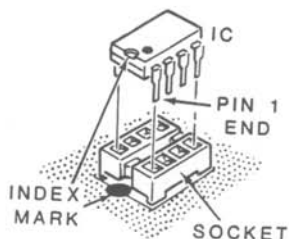

- (/) Q1: Position an MPSA20 transistor (#417-801) so its flat is over the outline of the flat on the circuit board. Then start the leads into their respective holes. Position the transistor 1/4" above the board. Solder the leads to the foil and cut off the excess lead lengths.

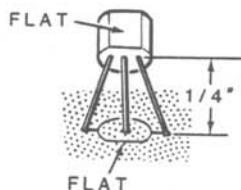

NOTE: In some of the following steps, you will install disc-type ceramic capacitors. When you install these ceramic capacitors, do not push the insulated portion of the leads into the circuit board holes. This could make it difficult to solder the leads to the foil.

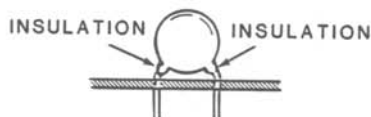

Refer to Pictorial 1-3 (Illustration Booklet, Page 2) for the following steps.

Install ceramic capacitors in Section 1 of the circuit board as follows:

- (/) C2: 270 μ F ceramic.
 (/) C4: 270 μ F ceramic.
 (/) C7: .001 μ F (.001) ceramic.

NOTE: In some of the following steps, you will install electrolytic capacitors. Before you install an electrolytic capacitor, look at it and identify the leads. One lead will have a positive (+) mark or a negative (-) mark near it. Be sure to install the positive lead in the positive-marked hole, or the negative lead in the negative-marked hole.

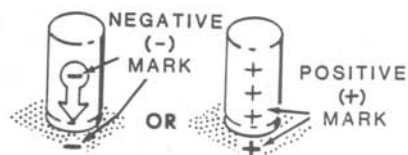

NOTE: Electrolytic capacitors are identified on the circuit board by the following outline.



- (/) C6: .47 μ F electrolytic.
 (/) C1: 2.2 μ F electrolytic.
 (/) C11: .02 μ F Mylar.
 (/) Solder the leads to the foil and cut off the excess lead lengths.

Install capacitors in Section 2 of the circuit board as follows:

- (/) C14: 4.7 μ F electrolytic.
 (/) C13: .47 μ F electrolytic.
 (/) C9: .01 μ F Mylar.
 (/) C15: 100 pF ceramic.
 (/) C12: 2000 pF polystyrene. Position the end with the band as shown. Also, position the capacitor approximately 1/8" away from the board.

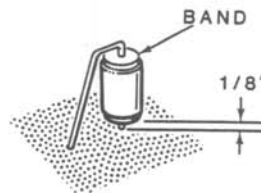

- (/) Solder the leads to the foil and cut off the excess lead lengths.

Refer to Pictorial 1-4 (Illustration Booklet, Page 2) for the following steps.

- (✓) Position the circuit board as shown.
- (✓) Mount the battery holder at A with two 3-48 × 1/4" screws, #3 lockwashers, and 3-48 nuts.
- (✓) SW1: Start the pins of the pushbutton switch (#64-920) into the holes in the circuit board and push it down tight against the board. Solder two pins (at opposite corners) to the foil. Make sure the switch is still down tight against the board, and then solder the remaining pins to the foil.
- (✓) Push the switch knob onto the switch shaft.

- (✓) Remove the nuts (if they have been installed) from the 100 k Ω (#10-1218) and two 1 M Ω (#10-1219) controls. Do not remove the flat washers. If the control hardware is packed loose, install a control flat washer, a control solder lug, and a control nut over each control shaft. Position the solder lugs as shown in Detail 1-4A and tighten the control nuts securely.

- (✓) R18, R14: Install two 1 M Ω controls in the circuit board. Insert the pins all the way into the holes. Make sure the shaft of each control is parallel with the board. Then solder the pins to the foil.

- (✓) R6: Similarly install the 100 k Ω control.

Refer to Detail 1-4A for the following steps.

- (✓) Cut a 5-1/2" bare wire. Insert one end of the wire in hole GND near control R18 and solder it to the foil.
- (✓) Route the wire through the solder lugs at R18, R14, and R6 to GND as shown. Solder the wire at each location and cut off the excess lead lengths on the foil.

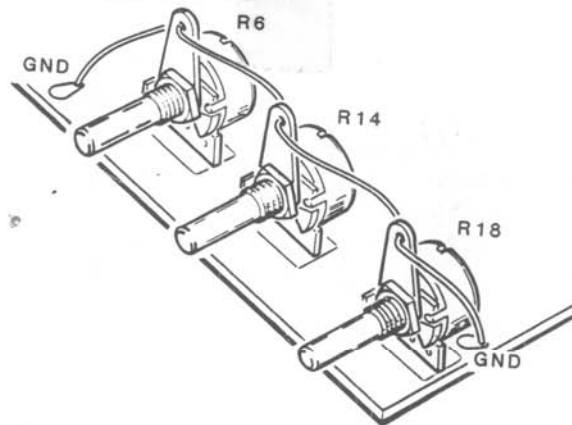

Detail 1-4A

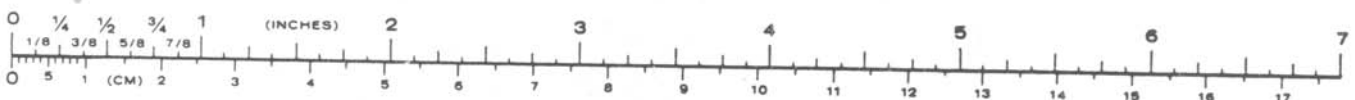

Heathkit®

(✓) Refer to Detail 1-5A and prepare both ends of a 2-1/2" shielded cable. Crimp and solder one end of a 1" bare wire to the shield lead at the indicated end.

(✓) Refer to Detail 1-5A and prepare both ends of an 8" shielded cable. Also, prepare the ends of a 2-3/4" shielded cable in the same manner.

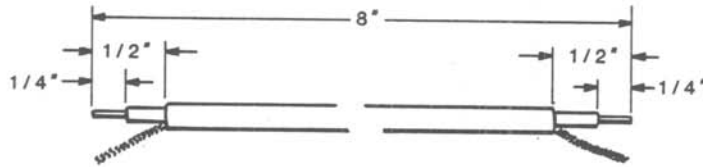
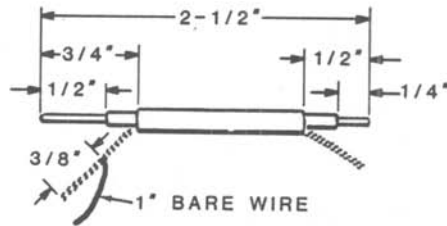

TAKING CARE NOT TO CUT THE OUTER SHIELD OF VERY THIN WIRES, REMOVE THE OUTER INSULATION.

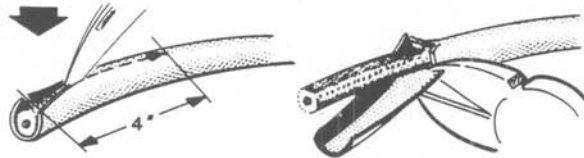

PUSH BACK THE SHIELD. THEN MAKE AN OPENING IN THE SHIELD AND BEND OVER AS SHOWN. PICK OUT THE INNER LEAD.



REMOVE THE INNER INSULATION AND STRETCH OUT THE SHIELD. APPLY A SMALL AMOUNT OF SOLDER TO THE END OF THE SHIELD AND THE INNER LEAD. USE ONLY ENOUGH HEAT FOR THE SOLDER TO FLOW.

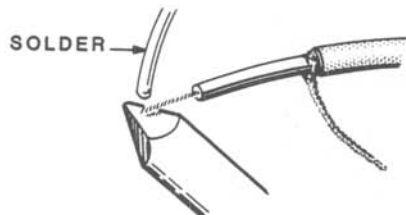

Detail 1-5A

Refer to Pictorial 1-5 (Illustration Booklet, Page 3) for the following steps.

Connect one end of these cables to the circuit board in the following steps. Solder the leads to the foil and cut off the excess lead lengths.

8" CABLE

- (✓) Inner lead to AUDIO OUT.
- (✓) Shield lead to GND.

2-1/2" CABLE

Connect the end opposite the end with the bare wire as follows:

- (✓) Inner lead to IN.
- (✓) Shield lead to GND.

2-3/4" CABLE

- (✓) Inner lead to OUT.
- (✓) Shield lead to GND.

OTHER WIRING

- (✓) Twist the battery connector leads together. Connect the black lead to BATT GND and the red lead to 9V IN. Solder the leads to the foil and cut off the excess lead lengths.

Refer to Detail 1-5B for the following steps.

NOTE: When a step directs you to prepare a wire, cut it to the indicated length and remove 1/4" of insulation from each end unless the step directs you otherwise.

- (✓) Prepare both ends of a 2" white wire and a 2" black wire. Remove 1/8" of insulation from one end instead of 1/4".
- (✓) Install a spring connector on the 1/8" end of each wire as shown in the inset drawing.

NOTE: In the following steps, you will insert the spring connectors that are on these wires into the 2-hole socket shell. Be sure to position the socket with the slotted side up and the connectors with the small tab up when you insert them.

- (✓) White wire in hole 1.
- (✓) Black wire in hole 2.

Refer to Pictorial 1-5 for the following steps.

Connect the socket wires to the circuit board in the following steps. Solder the wires to the foil and cut off the excess lead lengths.

- (✓) White wire in hole A.
- (✓) Black wire in hole B.

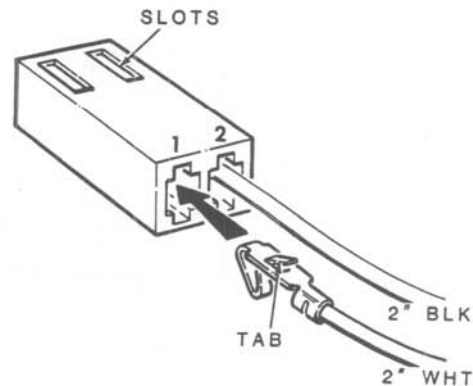
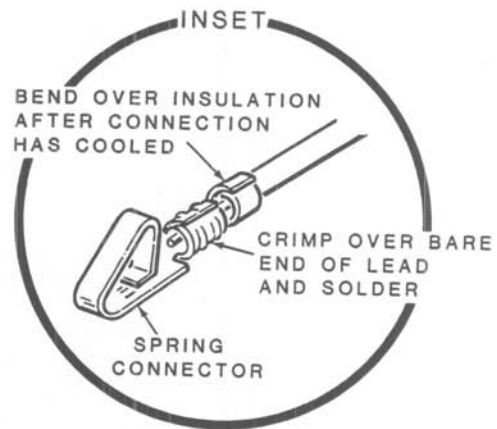

Detail 1-5B



Heathkit®

CIRCUIT BOARD CHECKOUT

Carefully inspect the foil side of the circuit board for the following most-commonly-made errors.

- Unsoldered connections.
- Poor solder connections.
- Solder bridges between foil patterns.
- Protruding leads which could touch together or touch the chassis when the circuit board is installed later.

Refer to the illustrations where parts are installed as you make the following visual checks:

- Electrolytic capacitors for the correct position of the positive (+) or negative (-) marked lead.
- Diode for the proper installation.
- Transistor for the proper installation.
- Integrated circuits for the proper installation.

Set the circuit board aside temporarily.

CHASSIS

Refer to Pictorial 2-1 (Illustration Booklet, Page 3) for the following steps.

- Position the chassis as shown.

NOTE: If there is paint on the inside of the chassis around the mounting holes for the parts you will mount in the next three steps, be sure to scrape it off.

- Remove the nut and lockwasher from the microphone jack if it has not already been done. Then mount the jack at J1 with this hardware as shown.
- Position the phone jack with the beveled corner as shown in the inset drawing. Mount the jack at J2 with a control lockwasher, control flat washer, and control nut.
- Mount four 4-40 spacers at locations B, C, D, and E. Use 4-40 x 3/16" screws. Do not tighten the screws at this time.

NOTE: When you install the bearings in the next step, you may have to cut them a small amount so they will fit into the chassis holes. Cut away only as much of each bearing as necessary so you can push it into the hole. See the inset drawing. It is important that the control shafts that will pass through these bearings do not touch the chassis. These bearings are quite brittle; therefore, do not use too much pressure when you install them.

- Install bearings in holes F, G, and H from the inside of the chassis.

Refer to Pictorial 2-2 for the following steps.

- Peel the backing from the four feet and install the feet on the bottom of the chassis approximately 1/4" in from each side.
- Carefully peel the backing from the blue and white label. Then press the label onto the bottom of the chassis in the area shown. Be sure to refer to these numbers on the label in any communications you have with the Heath Company about your kit.

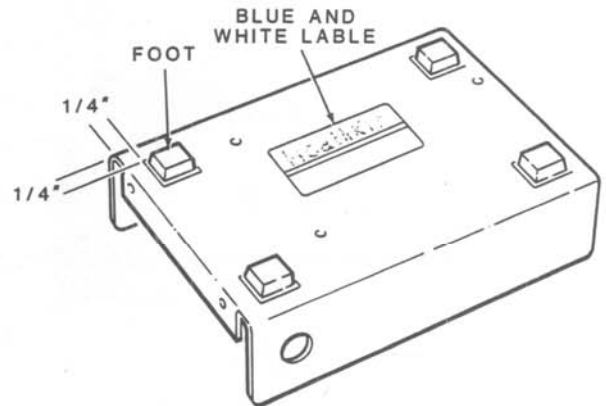

PICTORIAL 2-2

Refer to Pictorial 2-3 for the following steps.

- () Place the circuit board inside the chassis, inserting the controls into the three bearings and the switch knob into its hole.
- () Fasten the board to the four spacers with 4-40 × 3/16" screws and #4 lockwashers. Do not tighten the screws at this time.
- () Tighten the four spacer screws on the bottom of the chassis.
- () Make sure the switch knob is centered in the front panel so it does not bind. Then tighten the four circuit board screws.
- () Position the LED as shown in inset drawing #1. Shorten the shorter of the two leads to $1\frac{1}{2}$ " and the other lead to $\frac{5}{8}$ ".
- () D2: Insert the body of the LED into the hole at D2. Make sure the short lead is on the left as shown.
- () Refer to inset drawing #2 and cut 3/16" from the insulator on the side where the hole is closer to one edge.
- () Peel the backing from the insulator, install the insulator over the LED leads, and press the insulator onto the chassis.
- () Match the white wire of the 2-pin socket with the short lead of the LED. Then carefully insert the socket onto the leads of the LED.

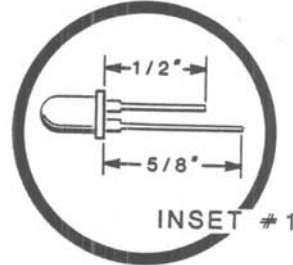
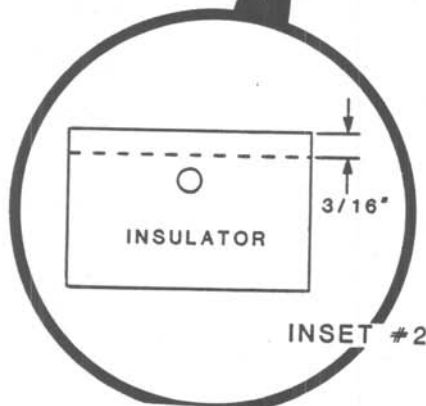
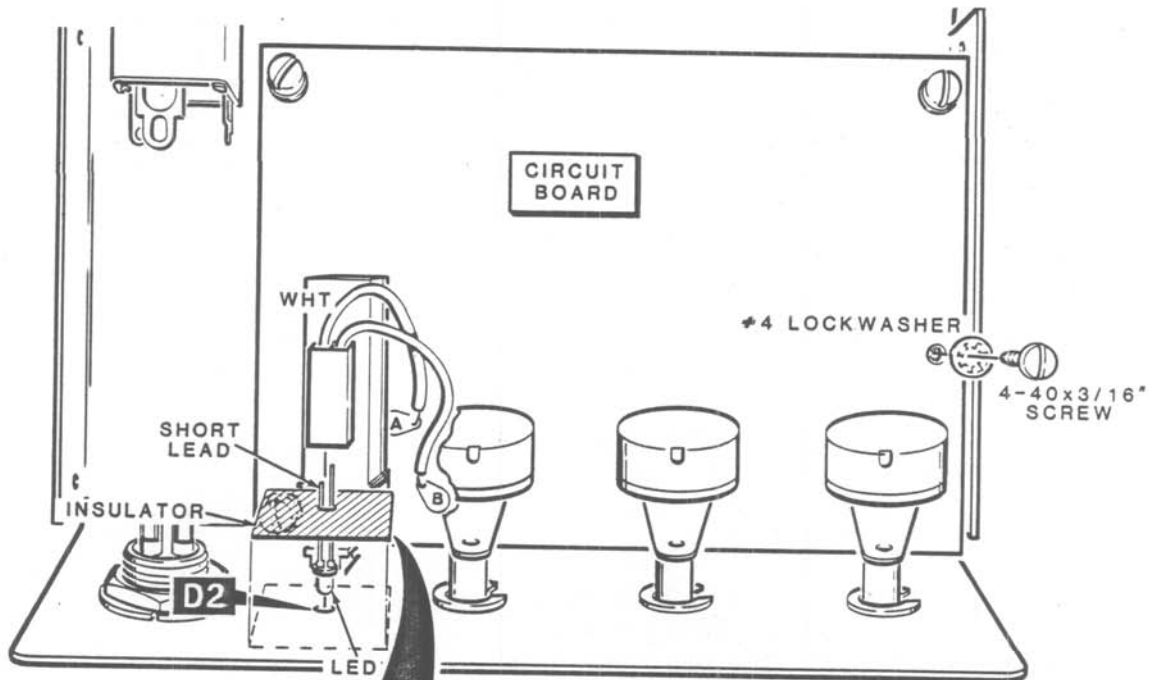

PICTORIAL 2-3



Heathkit®

Refer to Pictorial 2-4 for the following steps.

NOTE: In the following steps, (NS) means not to solder the connection because you will add other wires later. "S-" with a number, such as (S-1), means to solder the connection. The number following the "S-" shows you how many wires should be at the connection. This helps you check your work for errors as you go.

Connect the 8" and 2-3/4" cables coming from the board to jack J2 in the following steps.

8" Cable

- (/) Inner lead to lug 1 (NS).
- () Shield lead to lug 3 (NS).

2-3/4" Cable (from locations OUT and GND)

- (/) Inner lead to lug 1 (S-2).
- () Shield lead to lug 3 (NS).

When you connect the wires and cable to jack J1 in the following steps, just insert the ends into the hollow lugs. Do not bend them around the lugs. Refer to the inset drawing when you make the connections to the jack.

- (/) Prepare both ends of a 3" black and a 4" white wire. Remove 1/2" of insulation from one end of the white wire instead of 1/4".
- (/) Connect the black wire from lug 3 of J2 (S-3) to lug 4 of J1 (NS).
- (/) Cut both leads of a 270 pF ceramic capacitor to 1/2".
- (/) Insert one lead of the capacitor and the inner lead of the remaining cable into a ferrite bead.
- (/) Connect these two leads to lug 1 of J1 (S-2). Connect the other capacitor lead to lug 4 of J1 (NS).
- (/) Connect the shield lead of the cable to lug 2 of J1 (S-1). Connect the bare wire on this shield lead to lug 4 (S-3).
- (/) Slide a ferrite bead on the 1/2" bare end of the white wire. Connect this end of the wire to lug 3 of J1 (S-1).
- (/) Connect the other end of the wire to lug 2 of J2 (S-1).

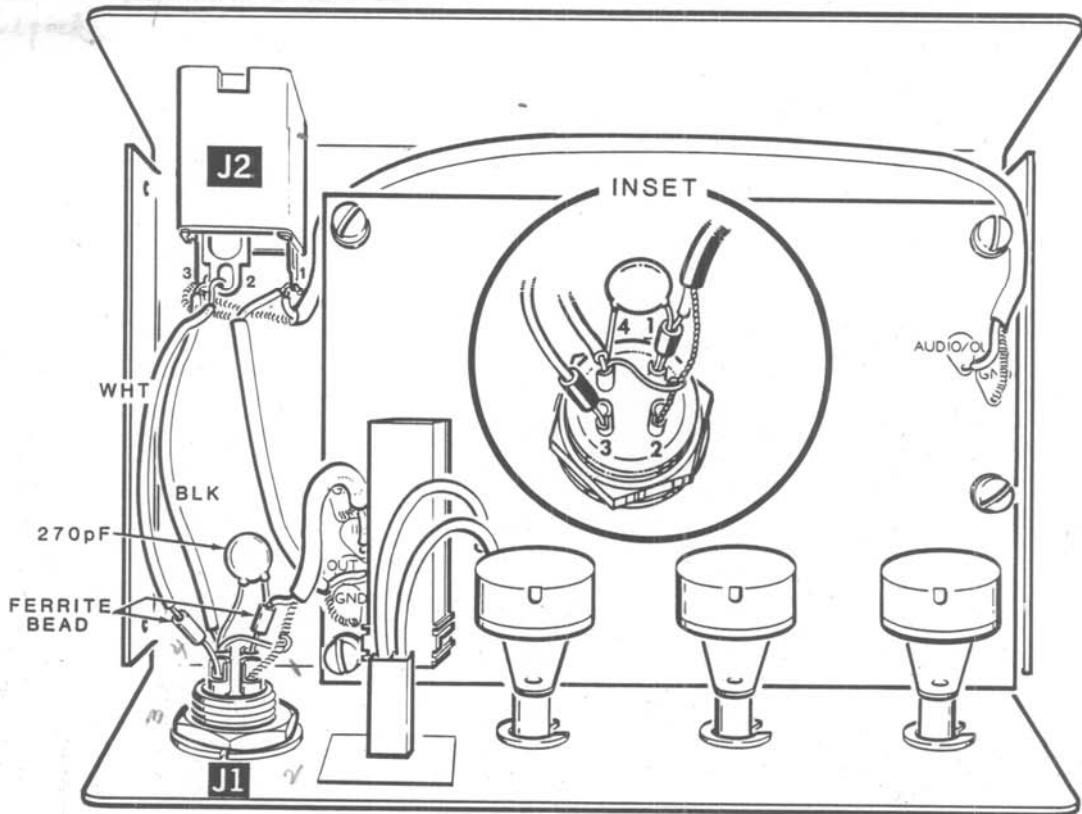

PICTORIAL 2-4

Refer to Pictorial 2-5 for the following steps.

- (1) Turn the shafts of the three controls fully counterclockwise.
- (2) Start a 6-32 × 1/8" setscrew into each control knob. Install each knob so the pointer is at the marker on the panel and tighten the setscrew.

MICROPHONE CABLE PREPARATION

You will have to prepare a cable to connect between your Transceiver and the Microlizer. These parts are not supplied and will have to be purchased. You will need a stereo 2-conductor phone plug, a microphone connector, and a 2-conductor with ground cable. Refer to Pictorials 2-6 and 2-7 (Illustration Booklet, Page 4) to install these parts on the cable. NOTE: The wiring of your microphone for your particular transceiver may vary from what is shown in the illustrations. Check the wiring diagram for your equipment and revise the wiring of this cable accordingly.

This completes the "Step-by-Step Assembly." Proceed to the "Initial Tests".

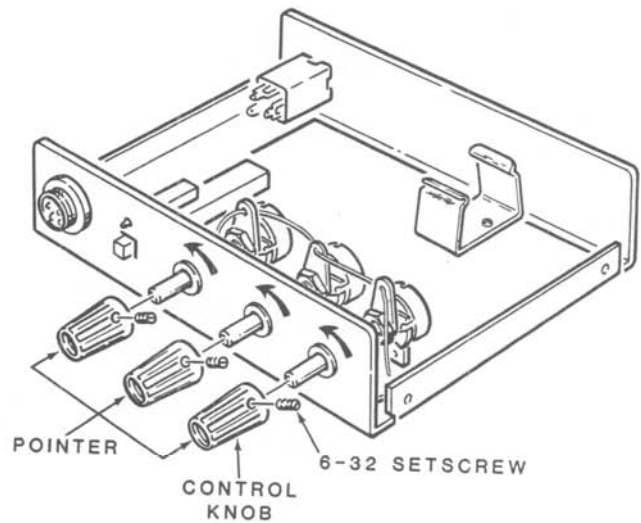

PICTORIAL 2-5

INITIAL TESTS

RESISTANCE MEASUREMENTS

You will need a volt-ohmmeter to perform the following tests. If you do not have one, proceed to "Operational Checks".

Refer to Pictorial 3-1 for the following steps.

If you get the correct results in the following tests, proceed to the "Operational Checks." If you do not get the correct results, refer to the "In Case Of Difficulty" section of this Manual and the Schematic Diagram.

NOTE: The Microlizer should not be connected to your microphone or transceiver at this time.

- (✓) Place the POWER switch in the OFF position (knob out).
- (✓) Turn the three controls to the midposition.
- (✓) Set your ohmmeter to the $R \times 100$ scale.
- () Connect one lead to lug 1 of J2 and the other lead to ground. The reading should be INFINITY. If you do not get the correct reading, reverse the leads and measure again.
- (✓) Set your ohmmeter to the $R \times 1000$ scale.
- (✓) Connect one lead to pin 8 of IC U1 and the other lead to ground. The reading should be *greater than* between 7 k Ω and 15 k Ω . If you do not get the correct reading reverse the leads and measure again.

OPERATIONAL CHECKS

- (✓) Install the battery connector on the battery. Then install the battery in the battery holder.
- (✓) Place the POWER switch in the ON position (knob in). The BATT TEST LED should light momentarily.

- (✓) Insert the phone plug, on the cable you have prepared, into phone jack J2 on the Microlizer. Connect the other end of the cable to the MIC INPUT of your transceiver.
- (✓) Connect your microphone cable to MIC on the Microlizer.
- (✓) Place the Microlizer POWER switch in the OFF position (knob out).
- (✓) Turn your transceiver on and adjust the MICROPHONE GAIN control on your Transceiver for proper operation.
- (✓) Place the Microlizer POWER switch in the ON position (knob in).
- (✓) Set the Microlizer LOW and HIGH controls to their midposition.
- (✓) Adjust the Microlizer MIC GAIN control to obtain the same drive level as before.
- () Now adjust the Microlizer LOW and HIGH controls for the correct high or low response that you want.

NOTE: A good way to know how you sound to others when you are transmitting, is to monitor your signal on a second receiver. Use high quality flat response headsets to minimize feedback.

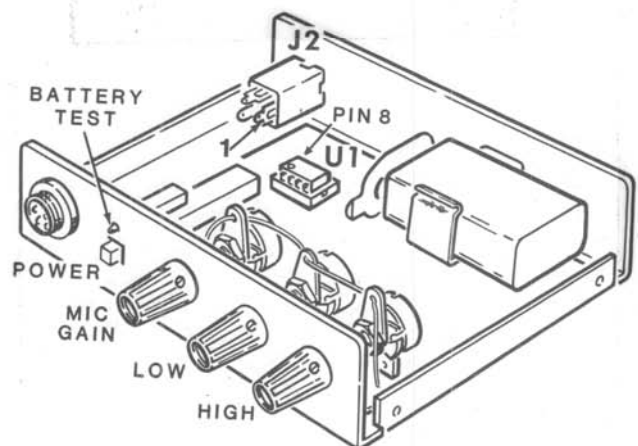

PICTORIAL 3-1

Refer to Pictorial 4-1 for the following steps.

- () Place the cover on the chassis and fasten it with four #6 × 1/4" sheet metal screws.

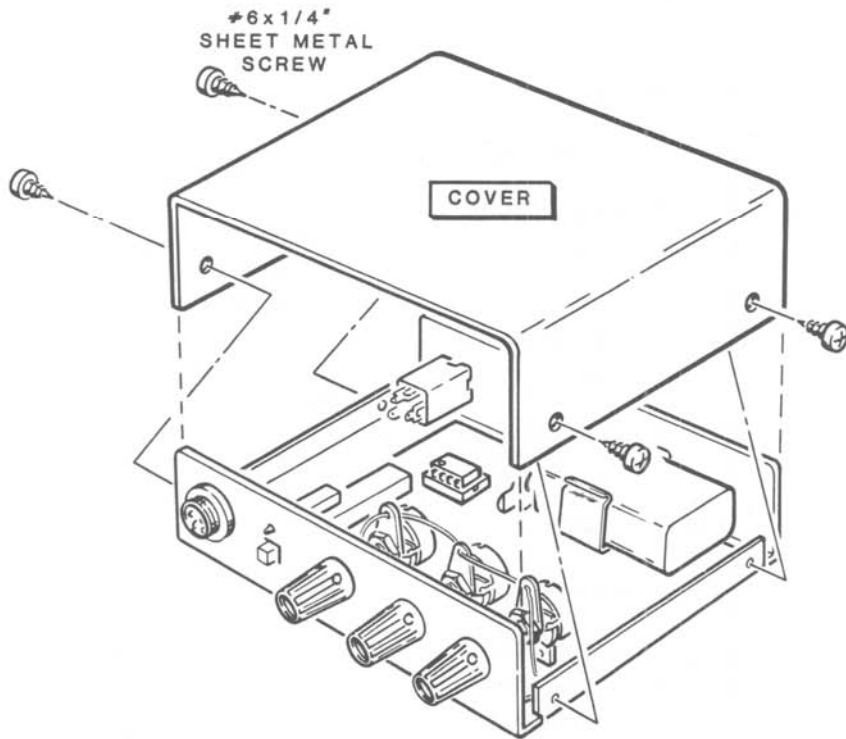

PICTORIAL 4-1

OPERATION

HIGH control	Varies the high frequency response.
LOW control	Varies the low frequency response.
MIC GAIN control	Varies the audio output.
POWER switch	When the switch is in the On position (knob in) the microphone input is fed into the Microlizer. When the switch is in the Off position (knob out), the Microlizer is bypassed and the microphone input is fed directly to the transceiver.
BATT TEST	When the Microlizer is turned On, the LED comes on momentarily and tests the battery. If the battery voltage is low, the LED will not light.
MIC	The input connector for your microphone.
PHONE JACK	The microphone output, which is fed to your transceiver.

IN CASE OF DIFFICULTY

This part of the Manual will help you locate and correct any difficulty that might occur in your Microlizer. This information is divided into two sections. The first section, "General," contains suggestions for reviewing your kit to locate possible causes of incorrect performance.

The second section is a "Troubleshooting Chart." This chart calls out specific problems that may occur and lists one or more conditions or components that could cause each difficulty.

NOTE: In an extreme case where you are unable to resolve a difficulty, refer to "Customer Service" information inside the rear cover of this Manual. Your Warranty is located inside the front cover.

GENERAL

1. Recheck the wiring. Trace each lead in colored pencil on the Pictorial as you check it. It is frequently helpful to have a friend check your work. Someone who is not familiar with the unit may notice something you consistently overlook.
2. Check for bits of solder, wire ends, or other foreign matter which may be lodged in the wiring.
3. About 90% of the kits that are returned for repair do not function properly due to poor connections and soldering. Therefore, you can often eliminate many troubles by reheating all connections to make sure they are soldered properly, as described in the soldering instructions in this Manual.
4. Check each circuit board foil to be sure there are no solder bridges between adjacent connections. Remove any solder bridges by holding a clean soldering iron tip between the two points that are bridged until the excess solder flows **down** onto the tip of the soldering iron.
5. Be sure the transistor and each integrated circuit is in the proper location (correct part number or type number). Be sure that each transistor lead is in the right hole and has a good solder connection to the foil. Check integrated circuits for proper positioning and for good contact at each pin connection.
6. Check capacitor values carefully. Be sure the proper part is wired into the circuit at each capacitor location. For example, it would be easy to mistake a .001 μF capacitor for a 100 pF capacitor. Check each electrolytic capacitor to be sure the lead near the positive (+) marking is at the correct position.
7. Check each resistor value carefully. It would be easy, for example, to install a 2200 Ω (red-red-red) resistor where a 220 Ω (red-red-brown) resistor is called for. A resistor that is discolored, or cracked, or shows any sign of bulging would indicate that it is faulty and should be replaced.
8. Be sure that the banded end of the diode is positioned correctly.
9. Check all component leads connected to the circuit boards. Make sure the leads do not extend through the circuit board and come in contact with other connections or parts, such as the chassis.
10. Check all the wires that are connected to the circuit board plugs. Make sure the wires do not touch the chassis or other lugs. Make sure all wires are properly soldered.
11. If you still cannot locate the trouble and a voltmeter is available, check the voltage readings against those shown on the Schematic Diagram. A review of the "Circuit Description" may help you locate the trouble.

NOTE: To remove faulty multi-lead components from a circuit board, clip all the leads, and then unsolder and remove them one at a time.

NOTE: Refer to the "Circuit Board X-Ray View" on Page 31 for the physical location of parts.

Troubleshooting Chart

This Troubleshooting Chart lists specific problems that could occur in your Microlizer and some possible causes. The numbers for the components are the same numbers used in the schematic diagram and circuit description. A circuit board X-ray view is

provided on Page 31 to help you locate any circuit board component. If a component is indicated (such as U1 for example) check that part and any other components associated directly with it to see if they are installed correctly.

PROBLEM	POSSIBLE CAUSE
Resistance reading was not infinity in resistance measurements.	1. Check cables between circuit board and J1 and J2 for shorts.
Resistance reading was not 7 kΩ to 15 kΩ in resistance measurements.	1. Solder bridge in vicinity of U1, U2, or 9-volt B+. 2. U1 or U2 installed incorrectly.
LED D2 does not light when SW1 is turned On (knob in).	1. D1 or D2 installed incorrectly. 2. Q1 installed incorrectly. 3. Battery low.
LED D2 lights and transceiver keys when SW1 is turned On (knob in). Low or no audio.	1. U1 or U2 defective. 2. Shielded cables wired incorrectly to J1 or J2.

SPECIFICATIONS

Adjustable Microphone Gain	
Low Cut Or Boost	± 12 dB at 490 Hz.
High Cut Or Boost	± 12dB at 2800 Hz.
Input Impedance	100 kΩ nominal.
Maximum Input Level	500 MV rms.
Frequency Response	200 Hz to 10 kHz.
Distortion5% or less.
Power Requirements	9-volt transistor battery.
Dimensions	5-3/4"W × 2"H × 4-1/4"D. (14.6 × 5.1 × 10.8 cm)
Weight	0.6 lbs.(0.3 kg).

Heath Company reserves the right to discontinue products and to change specifications at any time without incurring any obligations to incorporate new features in products previously sold.

CIRCUIT DESCRIPTION

You may use this Circuit Description if you wish to learn more about the operation of the Microlizer, or as an aid in troubleshooting the circuit. Refer to the Schematic Diagram (Illustration Booklet, Page 5) as you read.

The microphone input is coupled through capacitor C3 to pin 6 of the first preamplifier, U1A. Control R6 adjusts the gain of the preamplifier. The output signal is coupled through capacitor C6 to two active filter networks, U1B and U2A, and their frequency determining circuits. U1B is an active low response filter circuit centered at approximately 490 Hz, with a cut or boost of 12 dB, and is adjusted by control R14. The output at pin 1 of this filter is applied to the high filter network. The high filter response is centered at 2800 Hz, with a cut or boost of 12 dB, and adjusted by control R18. The output of the filtered signal from pin 1 of U2A is coupled through capacitor C13 to pin 6 of final amplifier input U2B. The output of U2B pin 7 is coupled through C14 to microphone jack J2.

Switch SW1 connects the microphone input to the Microlizer or straight through to microphone output jack J2. SW1 also switches the 9-volt battery and discharges capacitor C1 in the battery test circuit.

BATTERY TEST CIRCUIT

When switch SW1 is turned on, it allows transistor Q1 to conduct. Capacitor C1 determines the amount of time that transistor Q1 will be on. When transistor Q1 conducts, LED D2 is turned on for about a second. Diode D1 determines the level at which LED D2 will not light. This indicates that the battery should be replaced. When SW1 is turned off, C1 is discharged.

SEMICONDUCTOR IDENTIFICATION CHARTS

DIODES

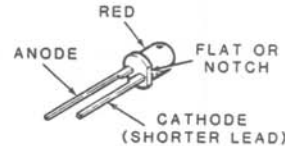
CIRCUIT COMPONENT NUMBER	HEATH PART NUMBER	MAY BE REPLACED WITH	IDENTIFICATION (TOP VIEW)
D1	56-59	1N5230B	<div style="border: 1px solid black; padding: 5px; margin-bottom: 10px;"> <p style="font-size: small; margin: 0;">IMPORTANT: THE BANDED END OF DIODES CAN BE MARKED IN A NUMBER OF WAYS.</p>  <p style="text-align: center; font-size: x-small; margin: 0;">BANDED END (CATHODE)</p> </div>
D2	412-633	Light-emitting diode (LED)	

TRANSISTOR

CIRCUIT COMPONENT NUMBER	HEATH PART NUMBER	MAY BE REPLACED WITH	IDENTIFICATION (TOP VIEW)
Q1	417-801	MPSA20	<p style="text-align: center; margin-bottom: 10px;">7 A</p> 

INTEGRATED CIRCUITS

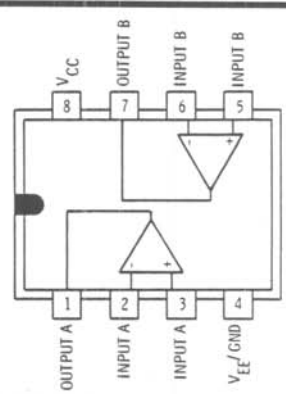
CIRCUIT COMPONENT NUMBER	HEATH PART NUMBER	MAY BE REPLACED WITH	IDENTIFICATION (TOP VIEW)
U1, U2	442-728		

CIRCUIT BOARD X-RAY VIEW

NOTE: To find the PART NUMBER of a component for the purpose of ordering a replacement part:

- A. Find the circuit component number (R5, C3, etc.) on the "Circuit Board X-Ray View."
- B. Locate this same number in the "Circuit Component Number" column of the "Parts List" in the front of this Manual.
- C. Adjacent to the circuit component number, you will find the PART NUMBER and DESCRIPTION which must be supplied when you order a replacement part.

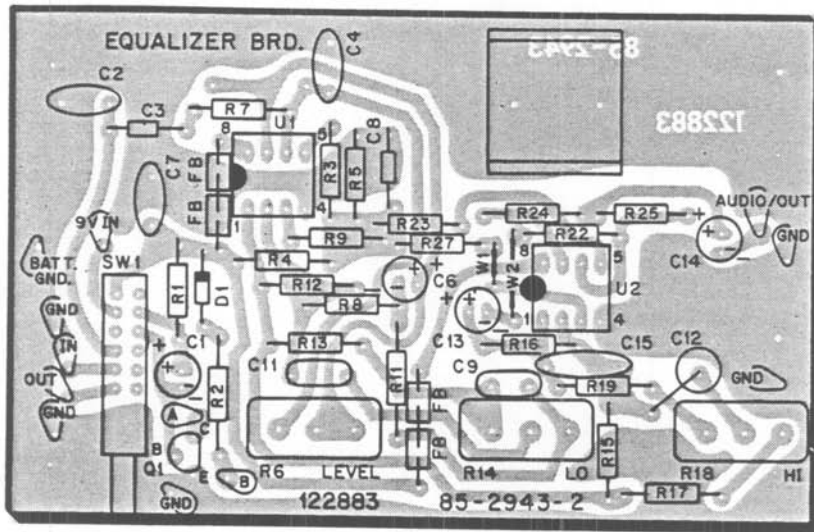

SHOWN FROM COMPONENT SIDE



CUSTOMER SERVICE

REPLACEMENT PARTS

Please provide complete information when you request replacements from either the factory or Heath Electronic Centers. Be certain to include the **HEATH** part number exactly as it appears in the parts list.

ORDERING FROM THE FACTORY

Print all of the information requested on the parts order form furnished with this product and mail it to Heath. For telephone orders (parts only) dial 616 982-3571. If you are unable to locate an order form, write us a letter or card including:

- Heath part number.
- Model number.
- Date of purchase.
- Location purchased or invoice number.
- Nature of the defect.
- Your payment or authorization for COD shipment of parts not covered by warranty.

Mail letters to: Heath Company
Benton Harbor
MI 49022
Attn: Parts Replacement

Retain original parts until you receive replacements. Parts that should be returned to the factory will be listed on your packing slip.

OBTAINING REPLACEMENTS FROM HEATH ELECTRONIC CENTERS

For your convenience, "over the counter" replacement parts are available from the Heath Electronic Centers listed in your catalog. Be sure to bring in the original part and purchase invoice when you request a warranty replacement from a Heath Electronic Center.

TECHNICAL CONSULTATION

Need help with your kit? — Self-Service? — Construction? — Operation? — Call or write for assistance. you'll find our Technical Consultants eager to help with just about any technical problem except "customizing" for unique applications.

The effectiveness of our consultation service depends on the information you furnish. Be sure to tell us:

- The Model number and Series number from the blue and white label.
- The date of purchase.
- An exact description of the difficulty.
- Everything you have done in attempting to correct the problem.

Also include switch positions, connections to other units, operating procedures, voltage readings, and any other information you think might be helpful.

Please do not send parts for testing, unless this is specifically requested by our Consultants.

Hints: Telephone traffic is lightest at midweek — please be sure your Manual and notes are on hand when you call.

Heathkit Electronic Center facilities are also available for telephone or "walk-in" personal assistance.

REPAIR SERVICE

Service facilities are available, if they are needed, to repair your completed kit. (Kits that have been modified, soldered with paste flux or acid core solder, cannot be accepted for repair.)

If it is convenient, personally deliver your kit to a Heathkit Electronic Center. For warranty parts replacement, supply a copy of the invoice or sales slip.

If you prefer to ship your kit to the factory, attach a letter containing the following information directly to the unit:

- Your name and address.
- Date of purchase and invoice number.
- Copies of all correspondence relevant to the service of the kit.
- A brief description of the difficulty.
- Authorization to return your kit COD for the service and shipping charges. (This will reduce the possibility of delay.)

Check the equipment to see that all screws and parts are secured. (Do not include any wooden cabinets or color television picture tubes, as these are easily damaged in shipment. Do not include the kit Manual.) Place the equipment in a strong carton with at least **THREE INCHES** of *resilient* packing material (shredded paper, excelsior, etc.) on all sides. Use additional packing material where there are protrusions (control sticks, large knobs, etc.). If the unit weighs over 15 lbs., place this carton in another one with 3/4" of packing material between the two.

Seal the carton with reinforced gummed tape, tie it with a strong cord, and mark it "Fragile" on at least two sides. Remember, the carrier will not accept liability for shipping damage if the unit is insufficiently packed. Ship by prepaid express, United Parcel Service, or insured Parcel Post to:

Heath Company
Service Department
Benton Harbor, Michigan 49022



HEATH COMPANY • BENTON HARBOR, MICHIGAN
THE WORLD'S FINEST ELECTRONIC EQUIPMENT IN KIT FORM

LITHO IN U.S.A.