

Jenal Communications

Model SC-3

Selcall Microphone

Programming Instructions

(Software Version 4.00)

(PCB Version 3.00)

IMPORTANT – READ THIS PAGE FIRST

Programming sequence for SC3 Selcall unit

All programming is carried out via the keypad on the SC3 microphone/Selcall unit. Programming mode is entered by holding both the ★ and # keys down together then switching on the unit. When programming mode is entered you will hear three short beeps, immediately release the ★ and # keys. You then have a maximum of eight seconds between key entries. The only allowable inputs are 1 to 9 and 0. (DO NOT PRESS ★ or # KEYS).

Programming takes the form:

S1 S2 S3 S4 M1

where S1 to S4 is the self ID of the Selcall unit and M1 is the "MODE 1" control word. If S1 to S4 are set as:

S1 = 8 S2 = 4 S3 = 6 S4 = 3

then the Selcall number of the unit is 8463

M1 determines the operating mode of the Selcall unit as shown on the following pages.

To calculate M1 first decide which functions you require and then add up the "Decimal" numbers next to the functions. The result is the number which has to be programmed into the MODE position.

For example it is required to programme the Selcall with a self ID of 8 4 6 3 and with the following functions:

	Horn Alarm	-	Piezo Alarm	-	Normal Mute	
therefore add	1	+	2	+	0	= 3 = M1

The programming sequence is then -- 8 4 6 3 3

After entering this sequence you will again hear three short beeps to signify the unit has been programmed. The unit is now ready for use.

If at any time in the programming sequence a long beep is heard then this indicates an error condition and programming will have to be started again. Note that in this case the previously entered programming details will be retained.

MODE 1

Bit 3	Bit 2	Bit 1	Bit 0	Decimal	Description
			0	0	Latch Alarm (continuous)
			1	1	Horn Alarm (pulsed for limited time)
		0		0	Audio Alarm
		1		2	Piezo Alarm
	0			0	Mute/Scan enabled
	1			4	Mute/Scan disabled
0				0	Normal Mute
1				8	Mute released during alarm tones

Valid codes are 0,1 to 9

MODE 1 Bit 0 = 0 (add decimal 0) - Switches alarm relay driver on for duration of main alarm (ringing) - approximately 96 seconds.

MODE 1 Bit 0 = 1 (add decimal 1) - Switches alarm relay driver on intermittently during main alarm period as follows:

- 00 to 24 seconds - OFF
- 24 to 48 seconds - ON for 1 second, OFF for 2 seconds
- 48 to 72 seconds - OFF
- 72 to 96 seconds - ON for 1 second, OFF for 2 seconds
- 96+ seconds - OFF

MODE 1 Bit 1 = 0 (add decimal 0) - Enables audio alarm via receiver audio stages.

MODE 1 Bit 1 = 1 (add decimal 2) - Enables audio alarm via microphone piezo alarm.

MODE 1 Bit 2 = 0 (add decimal 0) - Mute/Scan enabled. Mute (and Scanning) is controlled by the "★" key. On power-on the Mute/Scan is OFF (ie receiver is open) and each press of the "★" key alternates between Mute/Scan ON and Mute/Scan OFF.

MODE 1 Bit 2 = 1 (add decimal 4) - Mute/Scan disabled. Unit will not go into Mute or Scan mode. The "★" key is used only to cancel alarms and make beacon calls.

MODE 1 Bit 3 = 0 (add decimal 0) - Normal mute.

MODE 1 Bit 3 = 1 (add decimal 8) - Switched mute. Mute is switched off while audio alarms tones are generated. Mute is switched on during silence periods.

SC3 Selcall Microphone connections

Power input - RED - Voltage input from radio. The SC3 requires +5 to +15 volts at 55mA maximum. Current drain can be reduced by disconnecting the keypad LEDs.

Ground - SHIELD - Ground input from radio. (Use the microphone ground).

Receive audio input - BLUE - Receive audio input from radio - preferably from a fixed level source (ie. from detector output and not affected volume control). This line can also be used to inject alarm audio back into the radio by closing LK 1 on the SC3 micro board. Input level should be between 5mV and 3V peak to peak.

Alarm audio output - WHITE - Alarm audio output feed into radio. There are two alternative alarm outputs - High impedance and Low impedance. The High impedance output should connect into the radio audio circuits after the volume control and after any muting circuit. The level of the alarm can be preset by VR3 on the SC3 micro board. (The output level range can be changed by closing LK3 on the SC3 micro board). This output can be fed back down the receive audio input line if required by closing LK1 on the SC3 micro board. The Low impedance output may be suitable for directly driving a small loudspeaker.

PTT output - GREEN - This line is used to key the transmitter. The output is an open collector driver capable of sinking 350mA from 30volts.

Transmit audio output - YELLOW - This line carries the Selcall transmit audio when the PTT switch IS NOT pressed and carries the microphone audio when the PTT switch IS pressed. The transmit audio level should be set using VR2 on the SC3 micro board. Care should be taken to ensure the transmitter is not over-driven by the transmit audio level being too high.

Scan line - GREY - This line can be used to control the scanning of the radio. Two options are available by software selection - a)SCAN PULSES or b)SCAN STOP. If SCAN PULSES are selected then this line is normally HIGH and will pulse LOW for 100mS every 625mS (thereby scanning 8 channels every 5 seconds). This line can be used to pulse the "CHANNEL UP" line available on many radios to produce pseudo-scanning.

If SCAN STOP is selected then this line is normally HIGH to allow scanning and will go LOW to stop scanning.

The output is an open collector driver capable of sinking 350mA from 30volts.

(For a fuller description of operation see the **MODE 4 Bit 0** programming details.)

Alarm relay drive - ORANGE - This line can be used to drive a relay to switch on external alarm devices (ie. Flashing light, Horn alarm, etc.) as selected by **MODE3 Bit 0**. The output is an open collector driver capable of sinking 350mA from 30volts.

Mute line - PURPLE - This line can be used to control a mute circuit in the radio to switch off the audio output of the radio while waiting for calls. The mute circuit can be electronic or electro-mechanical (ie. a relay) as the output is an open collector driver capable of sinking 350mA from 30volts. The operation of the mute line is determined by **Mode 3 Bit 3** during programming. Mute on is active low, mute off is active high.

NOTE: Protection diodes should be used on any lines which are driving relays to prevent damaging the SC3 micro board.

SC3 Microphone internal wiring

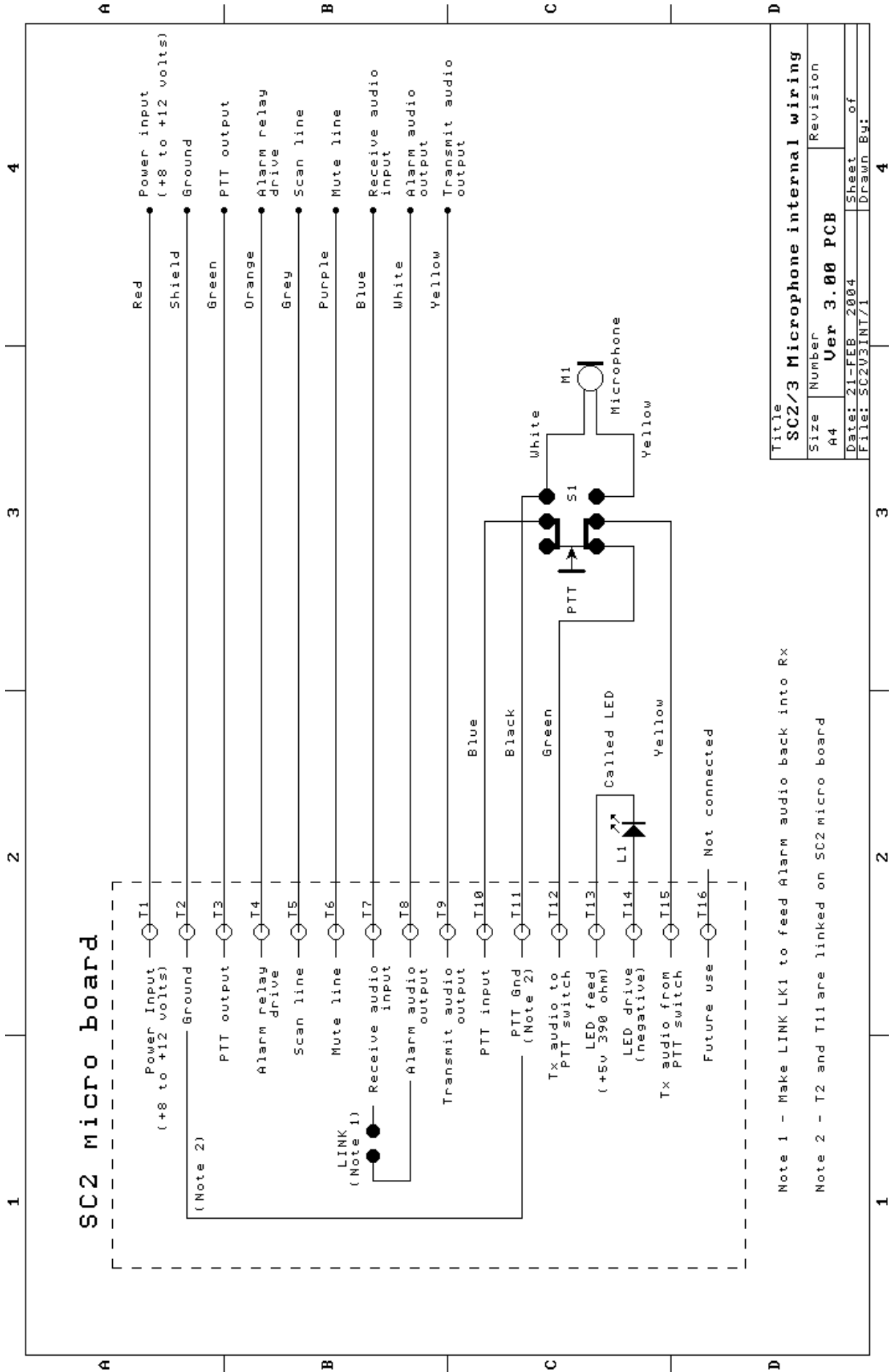

Title		SC2/3 Microphone internal wiring	
Size	Number	Revision	
A4	Ver 3.00 PCB		
Date:	21-FEB 2004	Sheet	of
File:	SC2V3INT/1	Drawn By:	

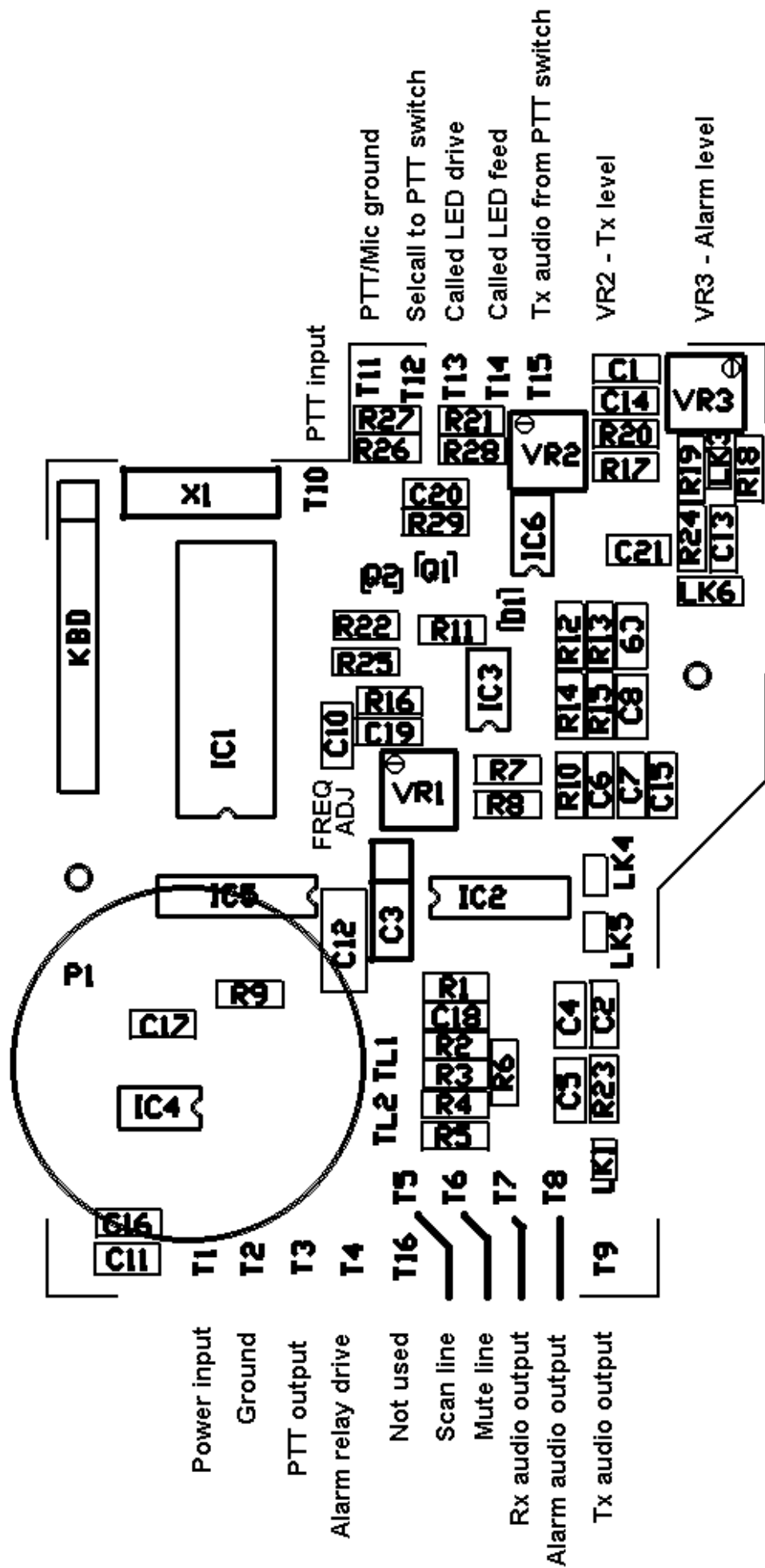

Top View - SC2/3 Version 3.00 PCB

SC2/3 Circuit board layout

SC3 Circuit board schematic

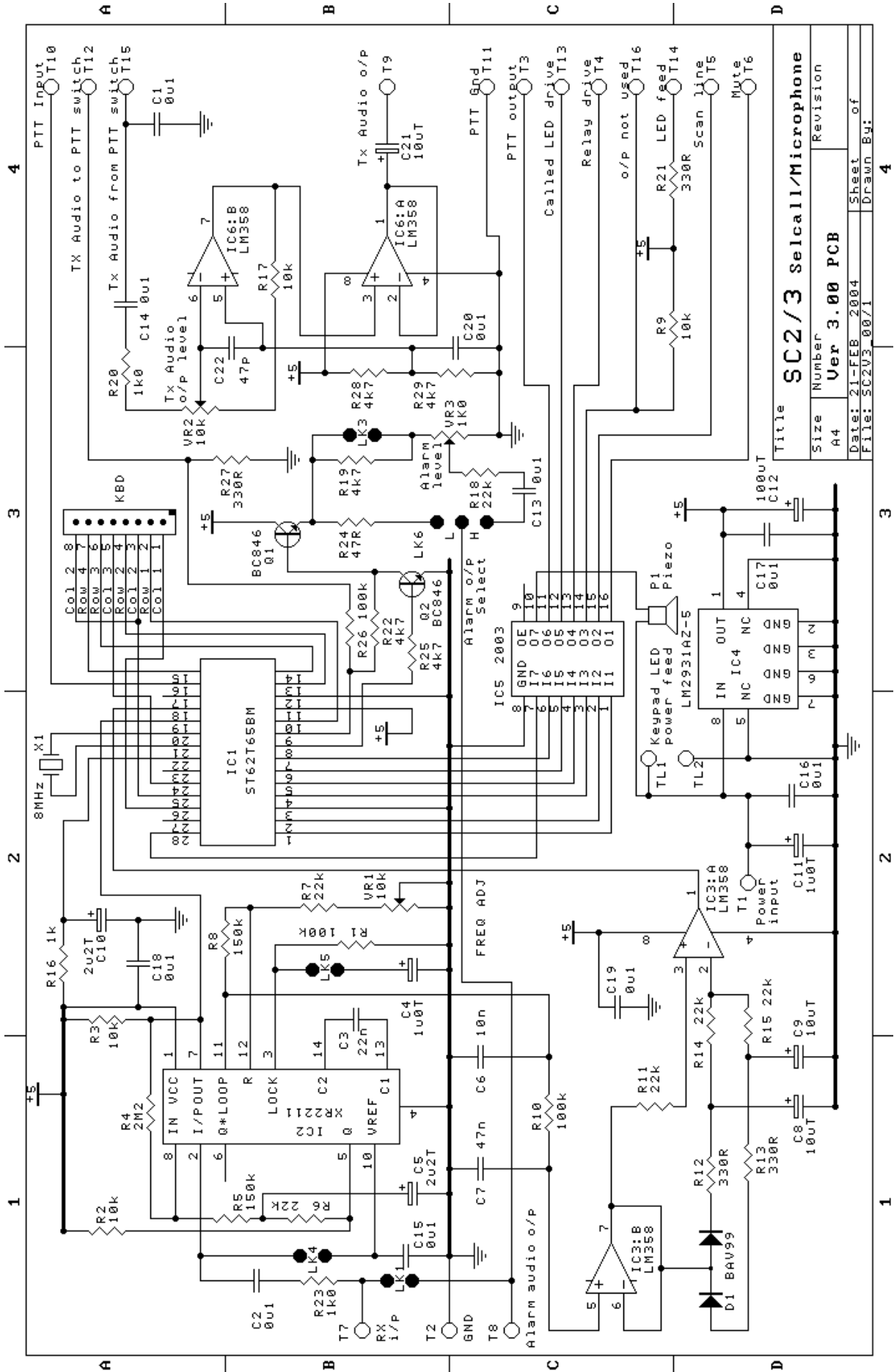

Title		SC2/3 Selcall/Microphone	
Size	Number	Revision	
A4	Ver 3.00 PCB		
Date:	21-FEB-2004	Sheet	4 of 4
File:	SC2V3_00/1	Drawn By:	

ADJUSTING THE SC3 SELCALL MICROPHONE

There are minimal adjustments to be made to the SC3 Selcall microphone. Programming of the Selcall self ID number and the various operating modes are covered separately in this Programming Instructions booklet.

Removing the SC3 micro board

First remove the back shell of the SC3 Selcall microphone by removing the three back shell screws.

To remove the SC3 micro board remove the two PCB retaining screws and lift straight up. When re-assembling the unit be careful to align the "Called" LED with the corresponding hole in the front shell.

FSK detector centre frequency

Note: When making this adjustment make sure there is no audio present on the receive input line. When measuring the FSK centre frequency a high impedance probe MUST be used. The frequency is factory preset and should not normally require adjustment.

Adjustment is made by VR1 (7 turn). First close link LK4 and open link LK5.

Measure the frequency on IC2 pin 3 (XR2211) and adjust VR1 for a centre frequency of 1785 Hz.

Finally open link LK4 and close link LK5.

Transmit Audio level

Adjust the Transmit Audio level by VR2 (7 turn) to give a suitable microphone level. Check that the output power is less than 70% of full output power while a Selcall is being transmitted.

Note: this adjustment adjusts both the microphone AND the selcall output levels.

Audio Alarm level

This adjustment is only necessary when using the High Impedance Audio Alarm option.

Adjust the Audio Alarm level by VR3 (7 turn) to give a suitable alarm level. If the available level is insufficient then it may be increased by closing link LK3.

The Audio Alarm may also be fed back down the receive input line by closing link LK1. The adjustment for the alarm level is still as above.

The High Impedance Audio Alarm option is selected by shorting Link H of LK6. This option is suitable for feeding into the receive audio amplifier change after any mute gate.

The Low Impedance Audio Alarm option is selected by shorting Link L of LK6. This option may be suitable for direct connection to a loudspeaker.

Alarm Tones

Alarm	Audio alarm sound	Piezo alarm sound
Key press	short high pitched tone	short beep
Error	long low pitched tone	long beep
Acknowledge	three short high pitched tones	three short beeps
Mute on	low to medium tone	long warbling beep
Mute off	medium to high tone	two short warbling beeps
Selcall received	one long telephone ring (one second) every 3 seconds	one long warble (one second) every three seconds
Telcall received	two short telephone rings every three seconds	two short warbles every three seconds
Background Selcall alarm	one short beep every five seconds	one short beep every five seconds
Background Telcall alarm	two short beeps every five seconds	two short beeps every five seconds

Using the SC3 Microphone Selcall unit

- To send a Selcall** - enter four digit Selcall number
- press "#"
- press "#"
- To send Selcall beacon request** - enter four digit Selcall number
- press "#"
- press "★"
- To send xx99 beacon request** - enter four digit Selcall number (must end in 99)
- press "#"
- press "#"
- To repeat a call or recall a caller** - press "#"
- press "#"
- To send a hang up command** - press "#"
- press "8"
(to station last called)

Notes:

The Mute is switched ON by pressing the "★" key. It can be switched OFF by pressing the "★" key or PTT. The Mute must be switched OFF (or disabled) before any keyboard entries (except "★") can be made

Alarms can be cancelled by pressing either the "★" key or PTT. This automatically turns the Mute OFF.

NOTES

Programming Code: _____ - _____
(Selcall ID Number) - (Operational mode)

Operational Mode on Power-up

(tick boxes for applicable options)

Mute/Scan Enabled
 Disabled

Horn Alarm Continuous
 Pulsed

Alarms Audio
 Piezo

Jenal Communications
P O Box 1108, MORLEY
Western Australia, 6943

Internet: <http://www.jenal.com>

Tel: Int.+61 8 9370 5533
Fax: Int.+61 8 9467 6146