

INSTRUCTION
FOR
MESSAGE KEYSER
Programmable Memory
model MK-1024

取扱説明書

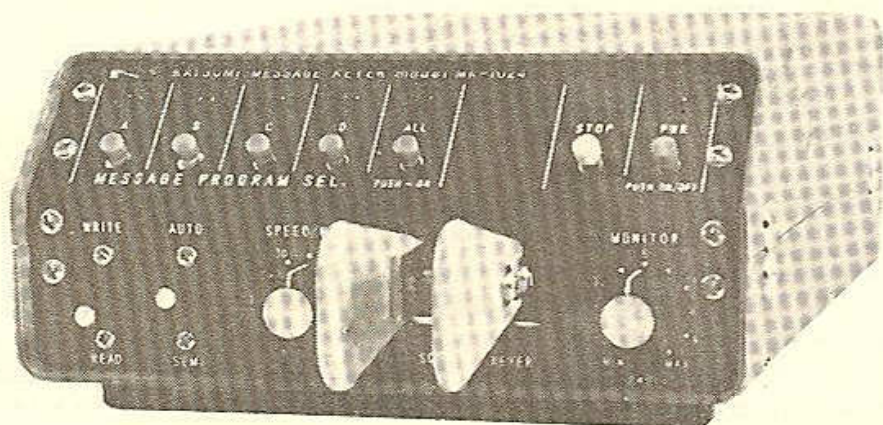

KATSUMI ELECTRIC CO., LTD.

27-5, Ikegami 4 Chome, Ota-ku, Tokyo, 146 JAPAN.

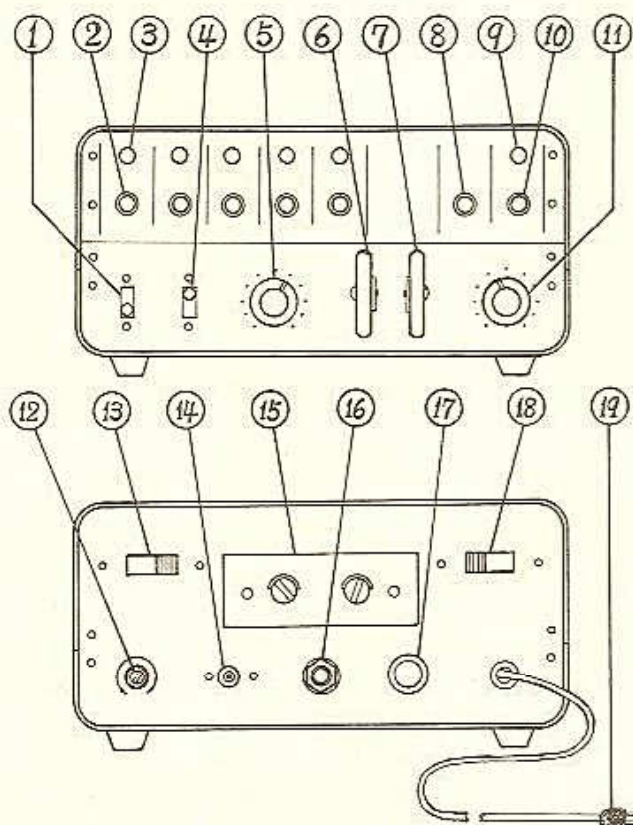

INSTALLATION INSTRUCTION

FEATURES

The model MK-1024 itself the dots, dashes and spaces in the precise ratio required for perfect code, at any speed desired by the operator.

Four independent 256 bits programmable memories or one 1024 bit long message memories. Pushbuttons both select and start a message run.

Memories are large enough for CQ/ID, and contest, schedule, test..... "Exchange"... all you do is send one call per contact! LED end of message indicator, Instant reset and STOP pushbutton.

Squeeze (JAMBIC) sending with full dot and dash memories. Plug-in unit P.C. B. and solid-state circuitry. Built-in sidetone with tone and volume control, switch for SEMI/AUTO. Built-in speaker and headphone jack.

Heavy duty transistor switch (2SB546) for 150V, 2Amp.DC. and with a built-in high speed plate relay for Max. 700V, 500mA any transmitter keying.

Operates on AC.100-120V/220-240V, 50-60Hz or external power DC. 9-14V.

OPERATION

- (1) Check polarity and the required keying voltage and current on your transmitter key terminals, using a tester (voltmeter-milliammeter) the key-up (open circuit) voltage must not be in excess of 150 volts D.C., and the key-down (closed circuit) current must not be in excess of 2 amperes (2000mA).
- (2) Connect the keyed line (15) on the rear panel terminal ⊕ to the POSITIVE keying terminal of the transmitter and the ⊖ to the NEGATIVE terminal, as previously determined by voltmeter test in (1).
- (3) Setting for AC line source voltage, carefully position the slide-switch (18) into the conformity for a small screw-driver use.
- (4) Plug in the power cord (19) to the 100-120V/220-240V, 50-60Hz alternating current supply. Set the PWR switch (10) to the pushbutton-ON, and the STOP switch (8) to the push. The pilot lamp (LED) (9) should light.

OPERATION OF ELECTRONIC KEYS

- (5) Moving the dual key levers (6) to the dot position (push to right for left key lever) should result in dots being heard from the speaker and moving the dual key lever (7) to the dash position (push to left for right key lever) should produce dashes.
- (6) Turn the speed control knob (5) to the desired, which may be instantly adjusted within the ranges of 6 to 60 W.P.M.
- (7) The monitor knob (11) control the volume of the speaker and headphone (16). Adjustable tone control (12) (tone pitch L:low, H:high).
- (8) The switch (4) on the AUTO position is normal use automatic dot-automatic dash, The SEMI position is automatic dot-manual dash alternate use and transmitter tune.

OPERATION OF MESSAGE PROGRAM MEMORY

- (9) Operation of this MK-1024 is quite simple. Programmable memory to write data into the memory, Set the slide-switch (1) to the WRITE position. The operator message program selects the desired memory with the start button switch (2) is push. The LED (3) should light. A quickly into the message for use with electronic keyer.
- (10) Approximately 30 characters can be stored in a 256 bit. Memory circuit is four (A.B.C.D.) 256 bits or one (ALL:A+B+C+D) 1024 bit approximately 120 characters each message memories.
- (11) If a mistake is made, simply depress the start button switch (2) again and start over. Even if the previous cycle is not complete, the counters will be reset to 000.
- (12) Operation is the same as described in the original article. Many time during a contest, especially during low activity periods, a message such as a CQ, callsign, text (such as RST or contest serial number) is to be repeated a number of times without having to manually recycle the memory each time.
- (13) To read the data in storage, Set the slide-switch (1) to the READ position. The operator message program selects the desired memory with the start button switch (2) is push, being sending message and heard from the speaker.
- (14) Four separate messages can be stored and selected by A.B.C.D. buttons (2). Again, the start button may be repressed at any time to restart the message.
CQ CQ DE JALFMK JALFMK K into message memorized, Sending message is
CQ * CQ CQ DE JALFMK JALFMK * CQ * CQ CQ DE JALFMK JALFMK K.,
* is repressed the start button (2).
- (15) Message read speed is turn the speed control knob (5) to the desired.
- (16) The STOP button (8) will hold sending, if a mistake is depress the start button (2), to use the STOP button switch (8).

External Connection

- (17) External power source D.C. 9-14 volts to adaptor jack (14), can be mobile use. negative-ground.
- (18) To use the external speaker or headphone, connect to the jack (16). output impedance is 8 ohms.

SPECIAL CONDITIONS

When the voltages and currents are greater than the values recommended in (1) above, various arrangements may be employed.

Generally, transmitter utilizing high voltage cathode keying will exceed the voltage values given above. These transmitter may be operated by using a built-in relay (Set the KEYING Switch (13) to RELAY position). Relay keying output is Max. voltage open circuit 700V, Max. current 500 mA.

CAUTION

DO NOT open the cabinet covers of the "ON THE AIR" sending. Possible damage to the MOS IC memory (uPD2102).

When you are WRITE (writing of MK-1024), Do not push the STOP switch (8) because this will interfere to the others channel code had been memorized in.

If a mistake is made, you can just simply push the MESSAGE PROGRAM SEL. switch (2) reset and do it again as before, (shown (11) OPERATION OF MESSAGE PROGRAM MEMORY).

On READ, even you push the STOP switch (8), it won't effect to the others channel.

〔工V・キ一部〕 ELE-KEY (EK-2)

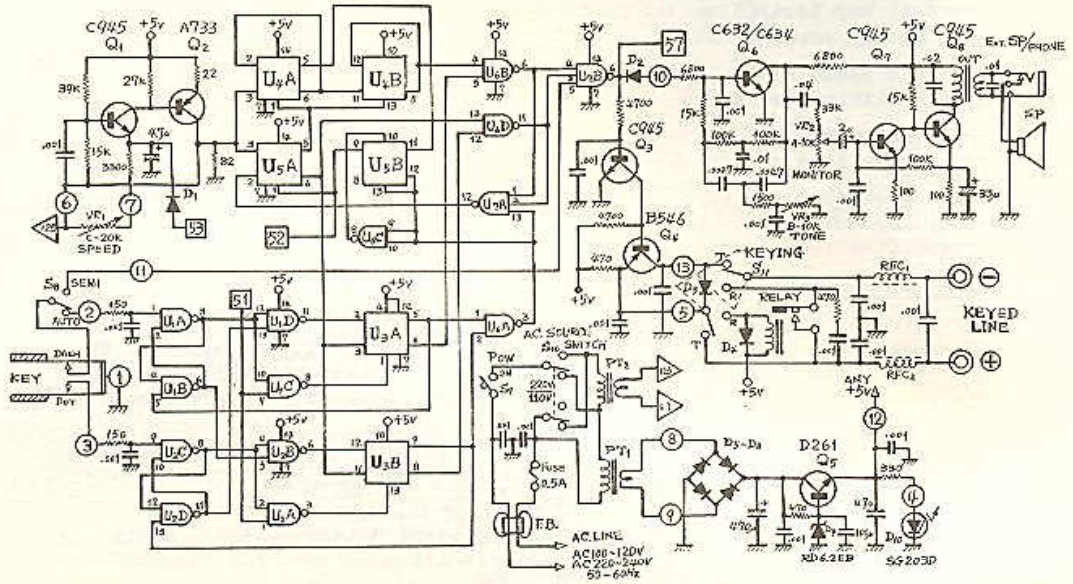

〔メモリ一部〕 MEMORY

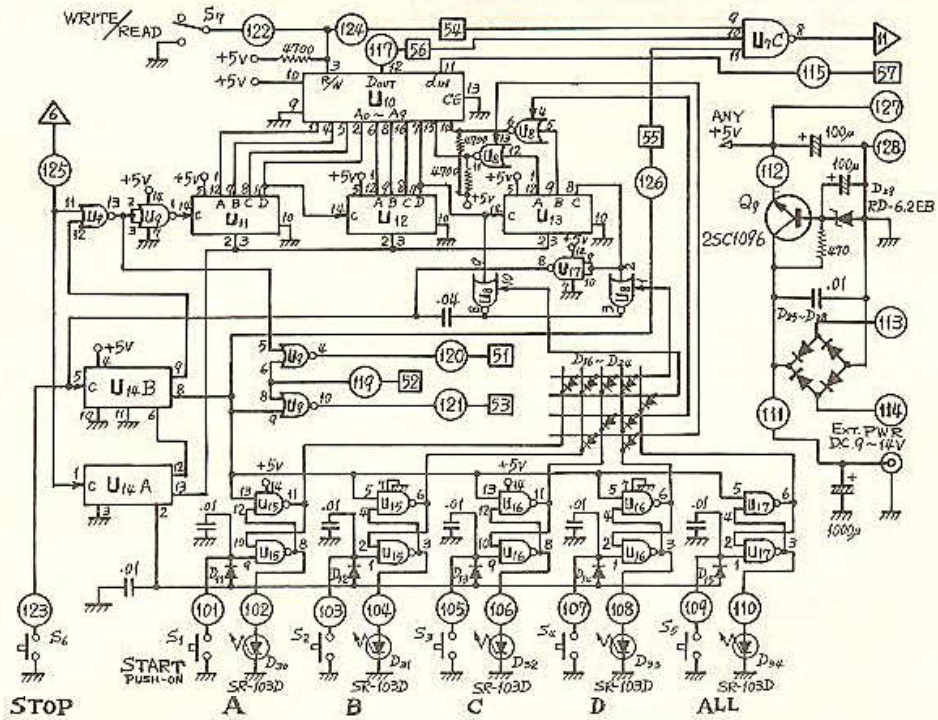

ICs

- | | |
|------------------|---------------------|
| U1, U2, U6: 7400 | U10: uPD2102 |
| U3, U4, U5: 7474 | U11, U12, U13: 7493 |
| U7: 7410 | U14: 7473 |
| U8: 74126 | U15, U16, U17: 7400 |
| U9: 7402 | |

(技術革新のため、予告なく定数および仕様を変更することがありますので、予めご了承ください。)