

QRPGuys Active 600Hz CW Audio Filter

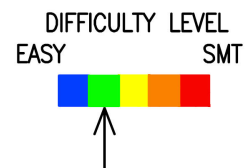

First, familiarize yourself with the parts and check for all the components. If a part is missing, please contact us and we will send one. *Please read all the instructions before starting the assembly.*

Parts List

- 1 – Audio filter pcb
- 1 – U1, TL072 IC
- 1 – U2, LM386 IC
- 1 – U3, 78L06
- 1 – D1, clear lens red led
- 2 – C1,2, .01uF mono capacitor, marked 103
- 5 – C3,6,7,8,9, .1uF mono capacitor, marked 104
- 1 - C4, 4.7uF electrolytic capacitor
- 1 – C5, 470pF mono capacitor
- 1 – C10, 100uF electrolytic capacitor
- 3 - R1,4,7, 22K resistor, (red-red-orange-gold)
- 1 – R2, 4.7K resistor, (yellow-violet-red-gold)
- 1 – R3, 180K resistor, (brown-gray-yellow-gold)
- 1 – R5, 10K 6mm potentiometer
- 2 – R6,10, 10K resistor, (brown-black-orange-gold)
- 1 – R8, 200K resistor, (red-black-yellow-gold)
- 1 – R9, 10 ohm resistor, (brown-black-black-gold)

- 2 – S1,2, SPDT slide switch
- 2 – J1,2, 3.5mm audio jack
- 2 – 8 pin dip socket
- 1 – “+” 9V battery clip-female
- 1 – “-“ 9V battery clip-male
- 4 – 3/8” dia. rubber foot

9 Volt battery not included

Refer to the graphic below and the PCB silk screening for the placement of the components.

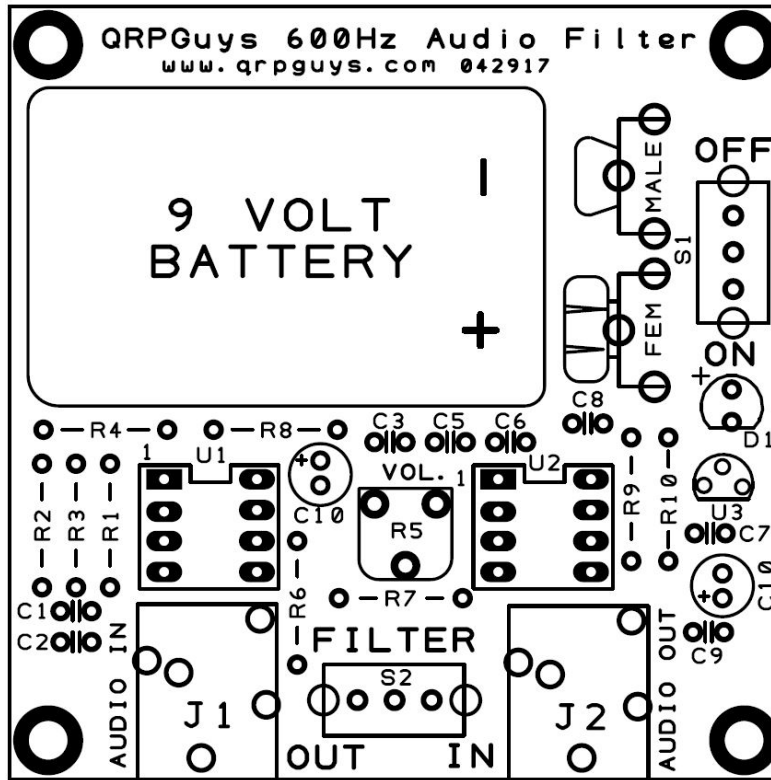

You will start with the smallest components first and progress to the larger ones.

- [] Install C1,2, .01uF mono capacitor, marked 103
- [] Install C3,6,7,8,9, .1uF mono capacitor, marked 104
- [] Install C5, 470pF mono capacitor
- [] Install D1, clear lens red led
- [] Install R1,4,7, 22K resistor, (red-red-orange-gold)
- [] Install R2, 4.7K resistor, (yellow-violet-red-gold)
- [] Install R3, 180K resistor, (brown-gray-yellow-gold)

- [] Install R6, 10, 10K resistor, (brown-black-orange-gold)
- [] Install R8, 200K resistor, (red-black-yellow-gold)
- [] Install R9, 10 ohm resistor, (brown-black-black-gold)
- [] Install R10, 220 ohm resistor, (red-red-brown-gold)
- [] Install 8 pin dip sockets
- [] Install R5, 10K 6mm potentiometer
- [] Install S1,2, SPDT slide switch
- [] Install U3, 78L06, *observe silkscreen outline*
- [] Install C4, 4.7uF electrolytic capacitor, *observe polarity, long lead is positive*
- [] Install C10, 100uF electrolytic capacitor, *observe polarity, long lead is positive*
- [] Install J1,2, 3.5mm audio jack
- [] Install “-“ 9V battery clip-male
- [] Install “+“ 9V battery clip-female
- [] Install U1,2, *note orientation of pin 1*



When inserting IC's the pins are flared so that they can be retained by auto insertion tools. Gently rock them on a flat surface so the pins are parallel and they will insert into the sockets more easily.

- [] Install 3/8" dia. rubber feet on the backside where indicated by silkscreen
- [] Install a 9V battery

This completes the assembly.

Usage:

QRPGuys Active Lowpass 600Hz CW Audio Filter is used at the audio output of your receiver or transceiver for filtering unwanted signals and noise that do not pass through it's fixed 600Hz active window. The S2 switch puts the filter in and out of the circuit. Adjustment of the Vol. pot is only necessary at setup to match the signal level with and without the filter. The 9V battery will last a long time, but should be turned off when not being used



QRPGuys 600Hz Audio Filter
www.qrpguys.com

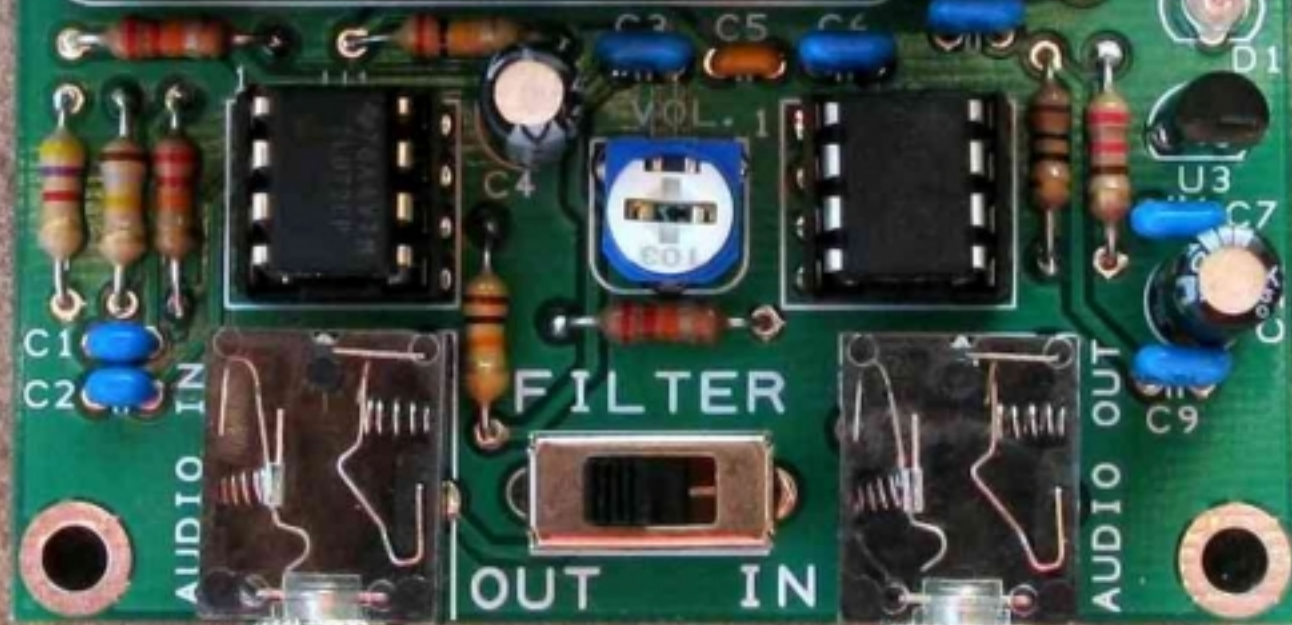

C1
C2

AUDIO IN

FILTER

OUT IN

AUDIO OUT

C3
C4
C5
C6
C7
C9
D1





9 VOLT
BATTERY

+

-

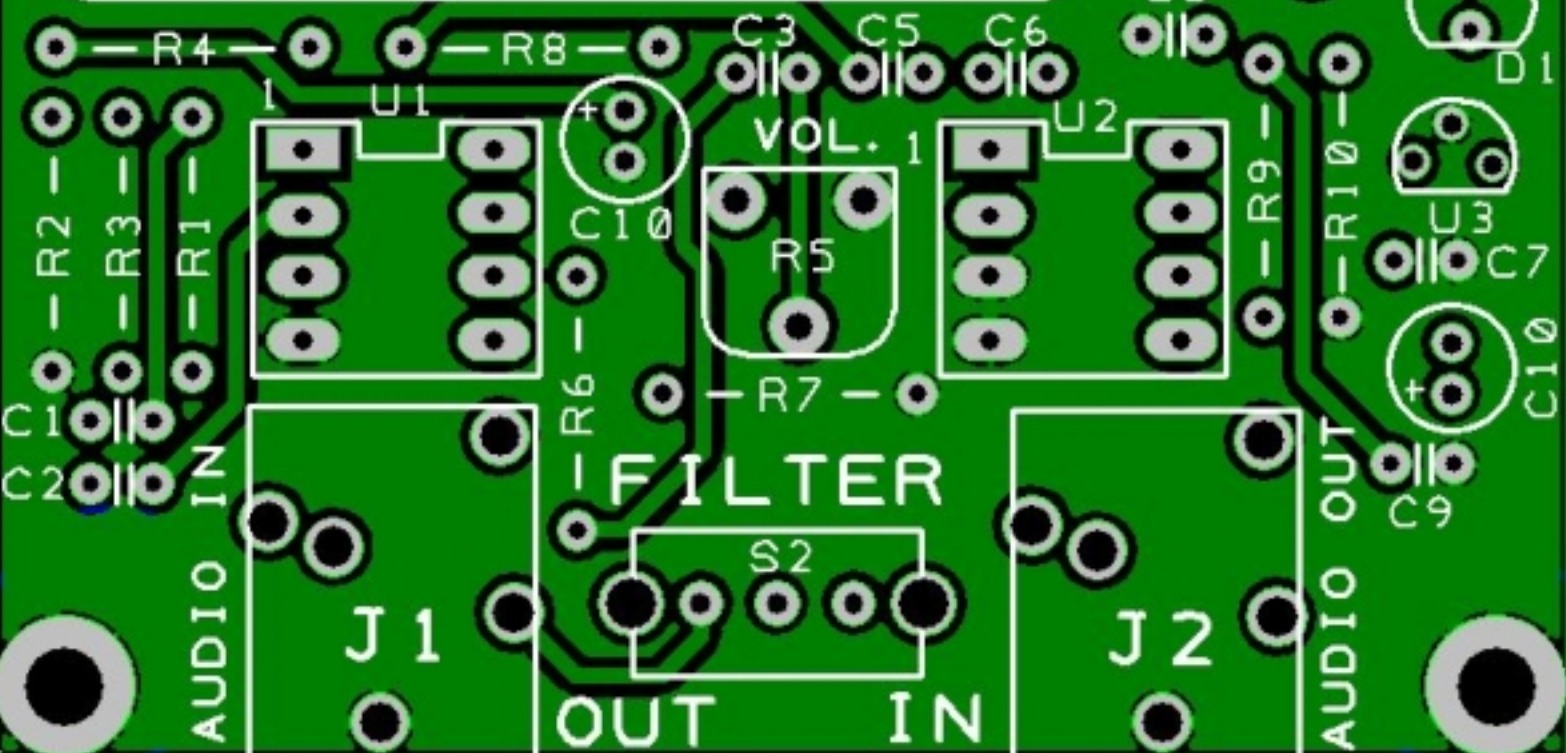

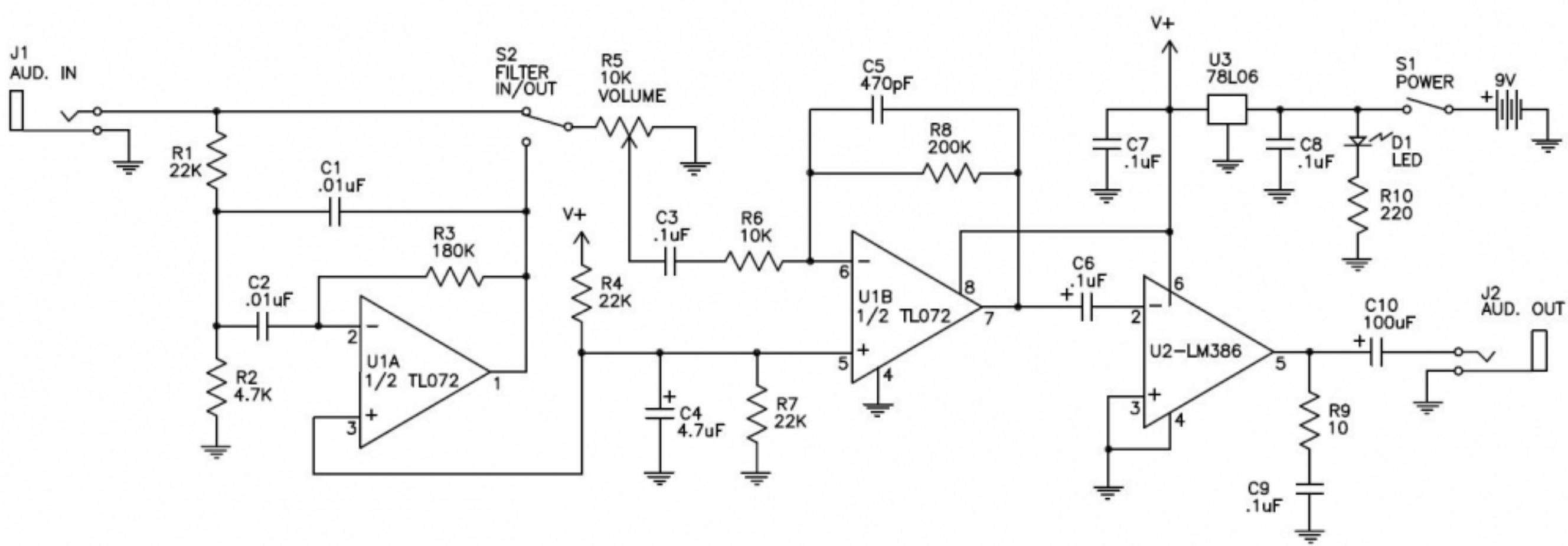

BodeDiagram

Magnitude[dB]

