

5-

MULTIPHASE RF ANALYZER
MODEL MM-1

INSTRUCTION MANUAL

127MX

CENTRAL ELECTRONICS, INC.
1247 WEST BELMONT AVE.
CHICAGO 13, ILLINOIS



MODEL MM-1 RF ANALYZER

The Multiphase Model MM-1 RF Analyzer is a compact 3" oscilloscope with self-contained 1000 cycle audio oscillator. It has been functionally engineered for maximum convenience in analyzing transmitter RF systems. A versatile instrument for design, service or continuous monitoring applications.

GENERAL INSTRUCTIONS

The MM-1 is shipped from the factory ready to operate. Connect to any convenient 115 volt 50-60 cycle outlet. It is suggested that you familiarize yourself with the following controls before placing unit in service. They are listed below in the proper sequence of operation.

OFF - ON - 1KC

Turns on AC power in mid-position. Turns on 1000 cycle pure tone in the 1KC position. For 2KC operation, see note on circuit diagram.

FUNCTION

Selects mode of operation; MAN provides a recurrent base line for ENVELOPE patterns with sweep synchronized to 1KC oscillator.

NOTE! ALL OTHER POSITIONS OF THE FUNCTION SWITCH REQUIRE RF TO OBTAIN A PATTERN.

The SINE position is also synchronized with the 1KC oscillator. The SPEECH position changes the saw tooth sweep to a lower frequency for easier observation of voice waveforms. The AF TRAPEZOID position requires an audio connection to the modulator of an SSB or AM transmitter. In the RF TRAPEZOID position, the RF output of the exciter and linear amplifier must be connected through the MM-1.

INTENSITY

Increase clockwise until a line appears.

POSITION CONTROLS L-R and U-D

Adjust for left-right and up-down to center base line on cathode ray tube.

HORIZONTAL SIZE

Adjust to fill screen.

FOCUS

There will be some interaction between the Focus and Intensity controls. Adjust for best focus consistent with brightness desired.

CAUTION!!

Never advance the INTENSITY control to maximum, especially when viewing small patterns for long periods of time. Sustained brilliant patterns will burn or discolor the phosphor in the cathode ray tube.

TO AVOID ANNOYING ELECTRICAL SHOCK FROM AC LINE BY-PASS CAPACITORS, DISCONNECT THE MM-1 POWER CORD BEFORE MAKING CABLE CONNECTIONS.

CONNECTIONS FOR SPEECH ENVELOPE PATTERNS

Simply connect the RF output of the transmitter through the HIGH LEVEL coax connectors on the rear of the chassis to the antenna.

FIG. A

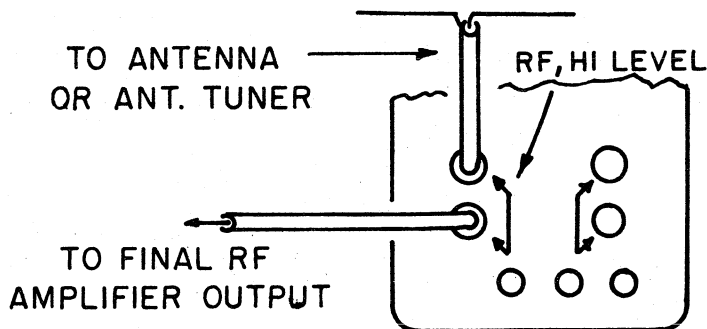

It is best to make the cable between the MM-1 and the transmitter as short as possible. In essence the RF output is fed right through the MM-1 to the antenna. No tuning is required throughout the frequency range of 1 to 55 MC. A small portion of the signal is sampled and fed to the vertical plates of the cathode ray tube. The VERTICAL SIZE is controlled by an RF attenuator calibrated in 3 db. steps. It should be set to 21 db. for 10-20A Multiphase Exciters and to about 12 db. for a Multiphase 600L. Avoid position 21 for power outputs in excess of 250 watts. In the SINE or SPEECH Envelope positions the pattern will disappear when the RF is turned off. This is controlled by the RF operated automatic beam blanking circuit.

ALTERNATE RF PICKUP CONNECTION

If other than coaxial cable is used a pickup antenna is necessary, or a coax coupled pickup link placed near the final RF amplifier plate coil. With open wire or ribbon feed systems, a length of wire in close proximity to one of the feeders is recommended.

CONNECTIONS FOR CW ENVELOPE PATTERNS

Use same RF connections as for SPEECH ENVELOPE Patterns. The keying speed should be varied until the pattern locks. An automatic key is recommended. Try either the SINE or SPEECH positions on the FUNCTION switch for best patterns.

CONNECTIONS FOR SINE ENVELOPE PATTERNS

In addition to the RF connections for SPEECH Envelope patterns it is necessary to connect the output of the LKC audio oscillator to the audio input of the transmitter.

FIG. B

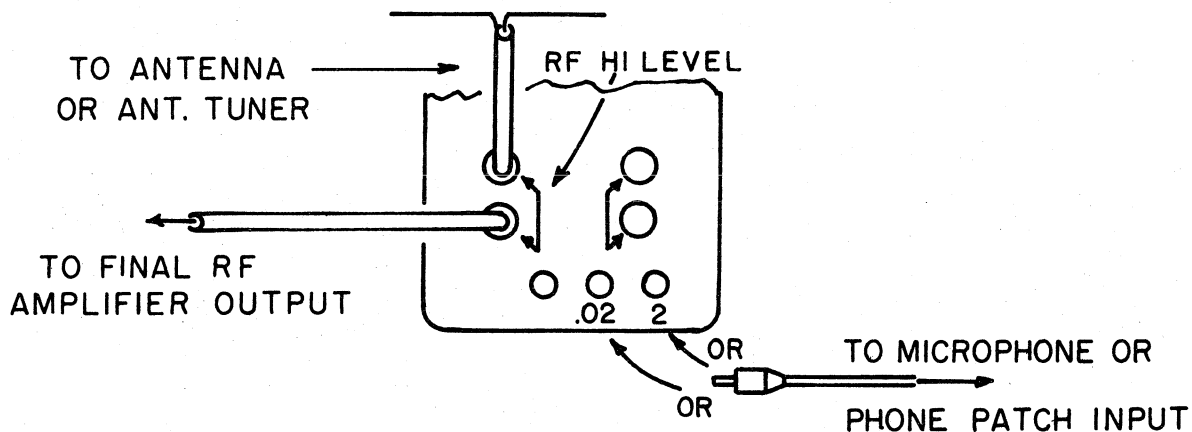

Two output levels are provided; .02 volts for use in the microphone connectors and 2.0 volts for use in phone patch or phono input jacks. Use a shielded audio cable. Connectors are furnished to go between the MM-1 and the AF INPUT or Phone Patch Jack on the 10B and 20A Multiphase Exciters. Plugging in disconnects the microphone circuit.

NOTE: The LKC output from the 2.0 volt jack on the MM-1 is intended to feed into an impedance of 50,000 ohms or higher. Since the phone patch input on a KWS-1 is about 680 ohms, it is necessary to use the .02 volt connection to prevent excessive loading on the LKC oscillator. As a further convenience the output of the LKC oscillator is controlled by the Power ON - LKC Switch. This allows the cables to remain connected and the tone to be applied by the switch on the MM-1.

The pattern is automatically synchronized with the 1KC oscillator in the MANUAL and SINE positions.

You will note during the alignment of phasing type SSB exciters that carrier leakage will show a given number of ripples on the envelope pattern, while unwanted sideband will show twice that number.

CONNECTIONS FOR AF TRAPEZOID OR BOW TIE PATTERNS

In addition to the RF and AF connections required for SINE Envelope patterns, it is necessary to obtain a sample of the transmitter audio signal appearing at the point where the audio modulates the RF.

FIG. C

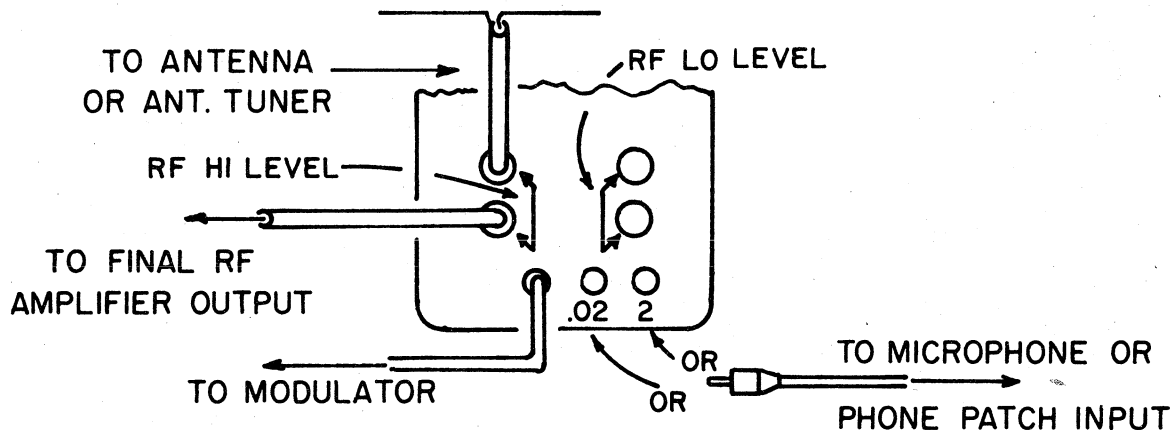

This point may be the secondary of a low voltage, low impedance transformer, as in the 10-20A Multiphase Exciters. Mount a phono connector on the rear of the chassis. Add a lead from connector to the RED lead on the Modulation Switch. This phono jack has been installed on 10B and 20A Exciters where the letter "C" follows the serial number.

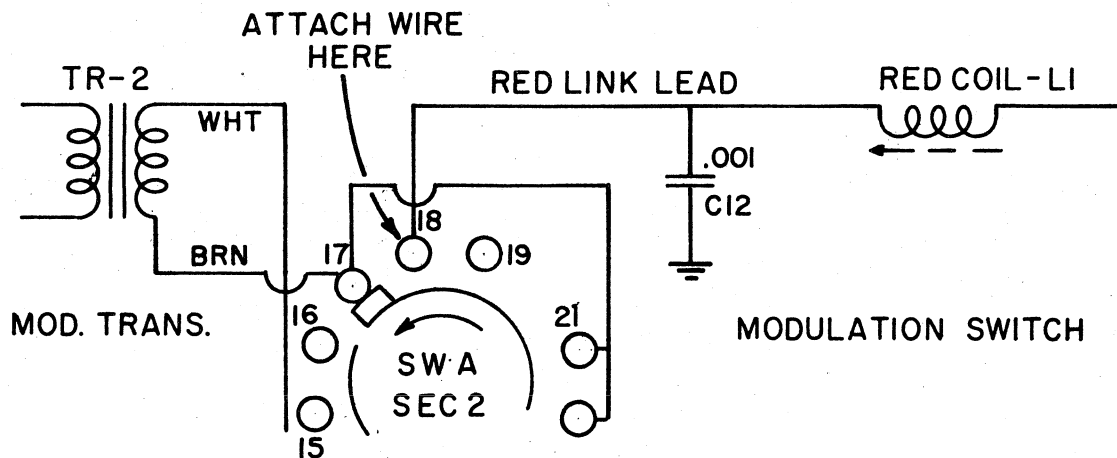

The audio sampling point might be a high voltage winding also carrying DC, as in the case of a plate or screen modulator for an AM transmitter. Where the voltage exceeds about 100 volts, a voltage divider will have to be used. Add another 100K 75 watt resistor in series with R1 for each additional 1000 plate volts.

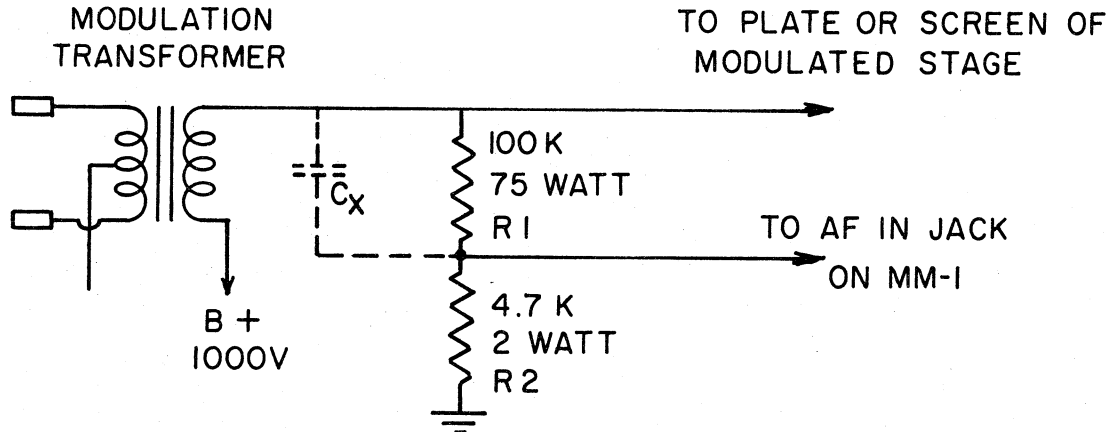

Cx may be required to correct for audio phase shift and should be a high voltage capacitor.

In systems where the modulating signal is less than 5 volts at high impedance, such as the grid of a receiving tube, the use of a cathode follower is recommended.

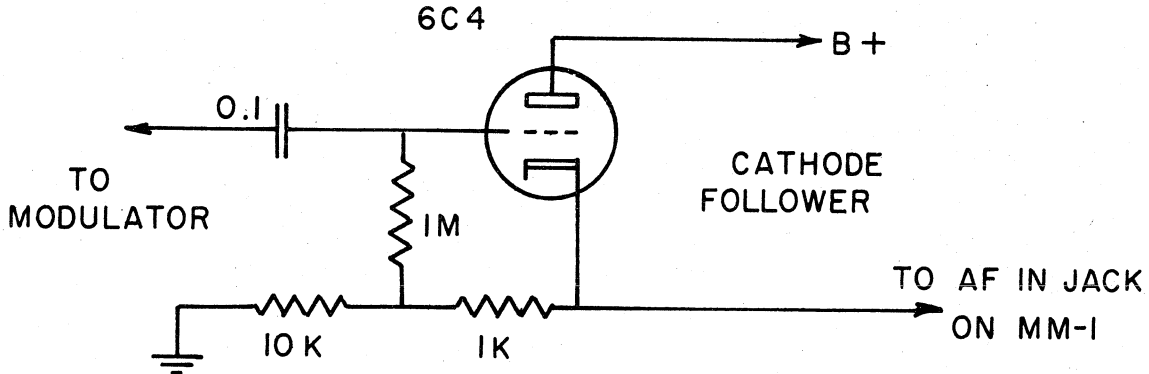

The sampled audio modulating signal obtained, as outlined above, is connected to the AF INPUT on the MM-1. Shielded cable is recommended. This signal is applied through the horizontal amplifier stage to the horizontal deflection plates of the cathode ray tube. To obtain a trapezoid pattern, an RF signal containing one sideband with carrier, or two sidebands with carrier (AM), must be applied to MM-1 as shown on Fig. C.

To obtain a BOW TIE Pattern an RF signal with two sidebands and no carrier should be applied to the MM-1. On 10-20A Multiphase Exciters, a convenient way to obtain this pattern is to set the modulation selector to AM and balance out the carrier.

CONNECTIONS FOR RF TRAPEZOID PATTERNS

This function is intended for evaluation of the "Linearity" of an RF amplifier stage. In addition to the connections required for SINE ENVELOPE it is necessary to connect the RF output of the exciter through the LOW LEVEL coax connectors to the input of the linear amplifier.

FIG. D

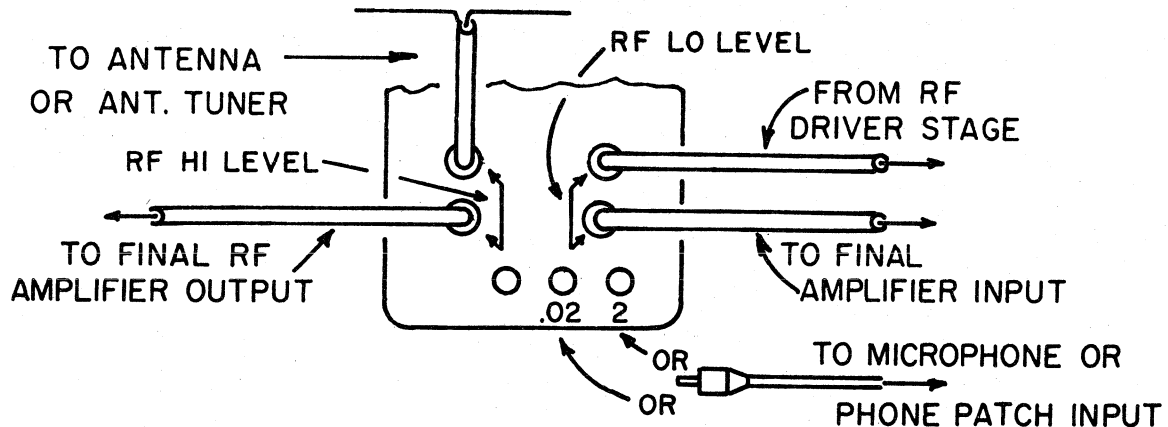

To obtain an RF Trapezoid pattern it is necessary to drive the linear amplifier with two sidebands and no carrier (DSSC = double sideband suppressed carrier), one sideband with carrier, or two sidebands with carrier (AM). On all Multiphase Exciters the AM position will furnish two sidebands with or without carrier. On filter type SSE exciters, one sideband and carrier will be required. The 1KC audio oscillator should furnish the modulating signal for the exciter.

The trapezoid pattern is obtained by comparing the RF output signal on the vertical plates to the demodulated RF input signal applied to the horizontal plates. The horizontal amplifier stage provides sufficient size from low power exciters. Do not apply more than 100 watts of RF power through the LOW LEVEL RF Input. If the driver stage is capable of power output in excess of this value, the RF energy for the LOW LEVEL Input should be sampled through a small variable capacitor and a T connector.

SERVICE INFORMATION

WARNING!!

Never operate this unit without the cabinet. Potentials in the vicinity of 1000 volts exist both above and below the chassis and should be treated with proper caution.

Exercise care when handling the cathode ray tube. It may become scratched and weakened to the point where it is easily broken, which may result in injury from flying glass particles.

REPAIRS

Under no circumstances should the instrument be returned to the factory without proper authorization and shipping instructions. In any correspondence with the factory concerning repairs, the serial number of the unit and a detailed description of the trouble must be given.

1KC AUDIO FREQUENCY OSCILLATOR ADJUSTMENT

A 12AT7 dual triode is employed as the audio frequency oscillator. Low distortion is obtained by adjusting the 5K feedback potentiometer R32 to the point where oscillation is just sustained.

WARNING!!

If R32 is too far counterclockwise the output will be rich in harmonics, which will make an otherwise excellent SSB exciter appear to have poor sideband suppression on an oscilloscope pattern.

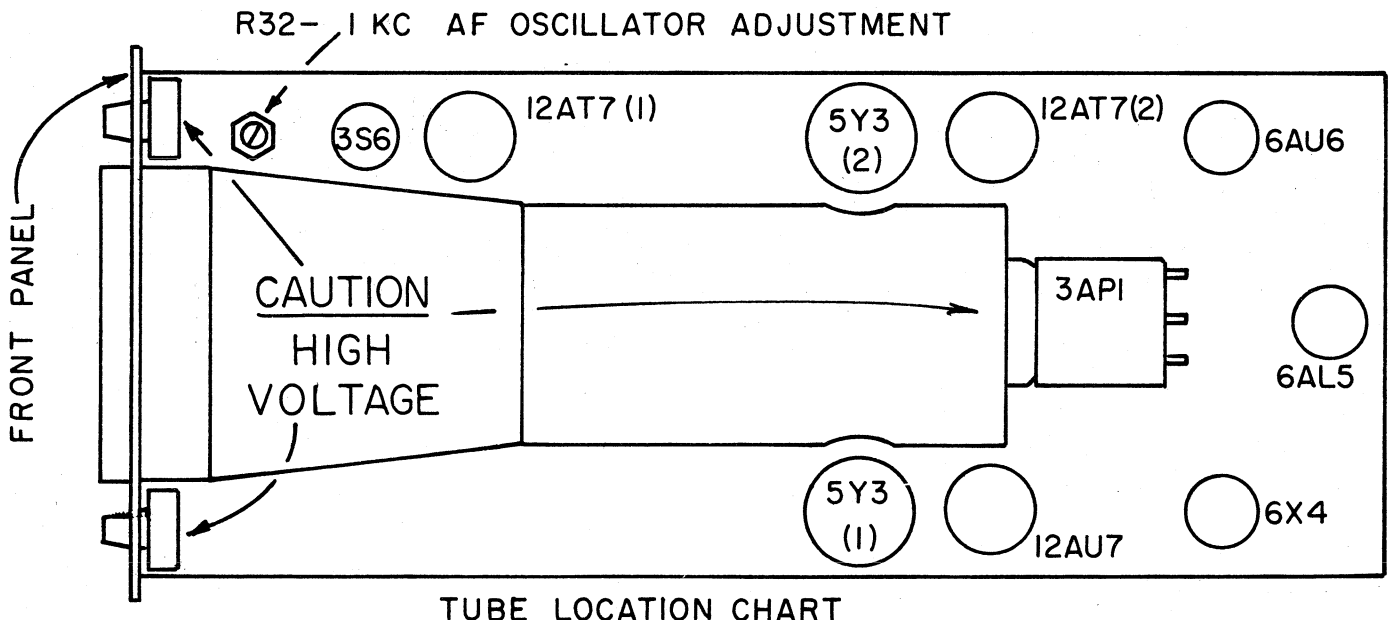

AUTOMATIC SPOT BLANKING CIRCUIT

If the automatic spot blanking circuit should fail to operate, the 12AU7 tube should be changed immediately and the blanking bias readjusted. Do not continue to operate the MM-1 if the spot blanking becomes inoperative.

BLANKING BIAS ADJUSTMENT

Potentiometer R38, located on the large bracket underneath the chassis, has been adjusted at the factory on all wired units.

If the 12AU7 Spot Blanking tube is changed, or the MM-1 has been assembled from a kit, proceed as follows:

- (1) Put FUNCTION switch in the MANUAL position.
- (2) Adjust the INTENSITY control to approximately 90% clockwise rotation.
- (3) Using a VTVM, or at least a 20,000 ohm per volt meter, adjust R38 for zero voltage at the arm of the potentiometer. The arm of the potentiometer is the center terminal.

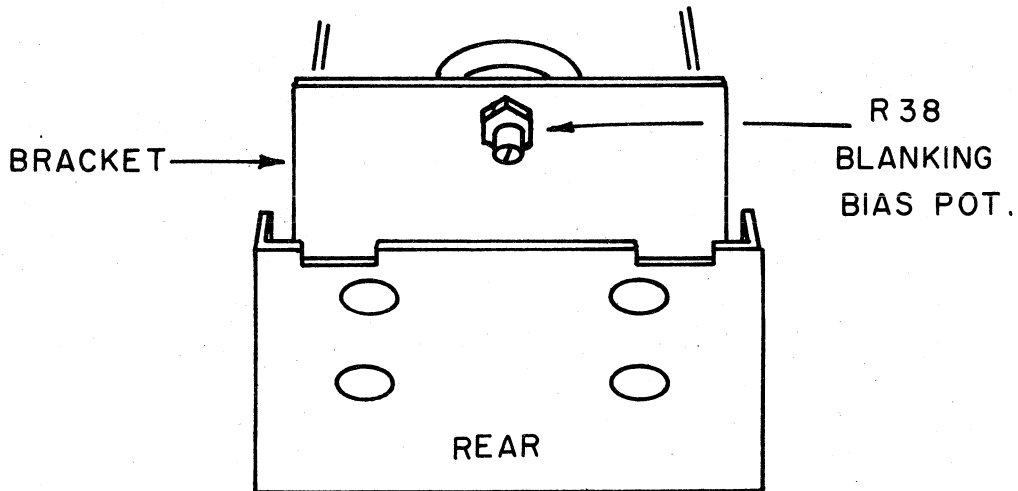

OPERATION OF THE SPOT BLANKING CIRCUIT

The RF INPUT signal is rectified in one half of the 6X4 Hi Level Rectifier. The positive DC output voltage is filtered and applied to the #2 control grid of the 12AU7 Spot Blanking control tube through the FUNCTION Switch. This tube is a DC amplifier to change the bias on the control grid of the cathode ray tube. When no RF is applied the CRT grid bias is approximately -80 volts. As RF is applied, the blanking bias approaches zero.

ENVELOPE PATTERNS

Pure CW Carrier

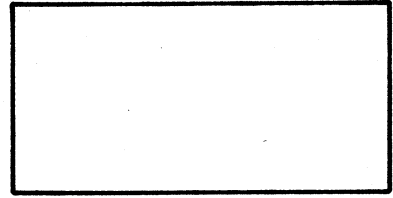

E1

CW Carrier with spurious radiation 10 db. down.

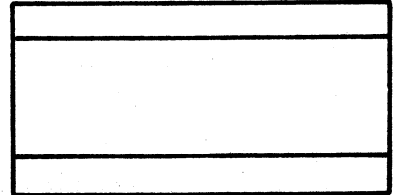

E2

CW Carrier with spurious radiation about 20 db. down.

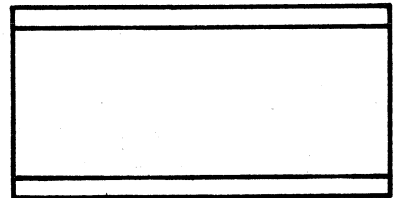

E3

SSB signal, voice input, correctly adjusted.

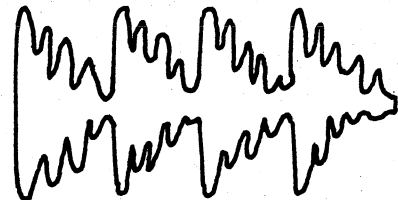

E4

SSB signal, voice input, slightly excessive speech gain, or insufficient amplifier loading.

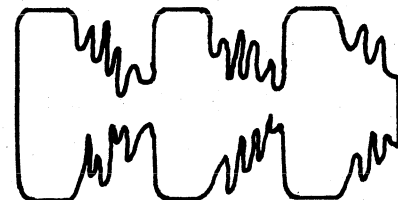

E5

SSB signal, voice input, badly overmodulated.

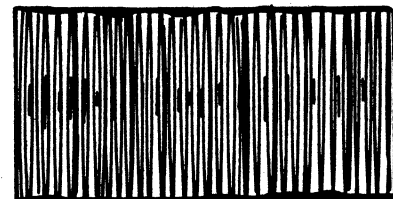

E6

SSB signal, tone input, sideband suppression approximately 40 db.

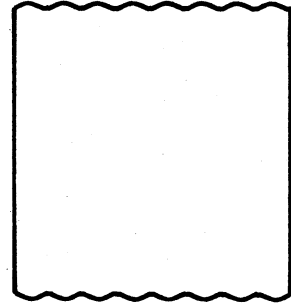

E7

Same as above. Sideband suppression 35 db.

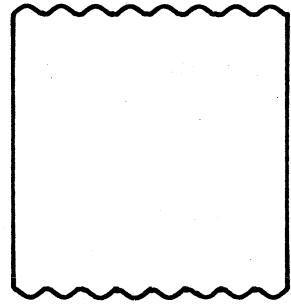

E8

Same as above. Sideband suppression 30 db.

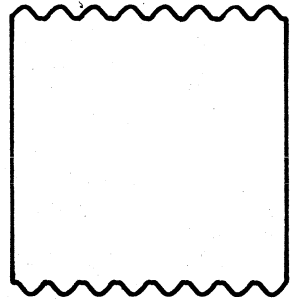

E9

Same as above. Sideband suppression 25 db.

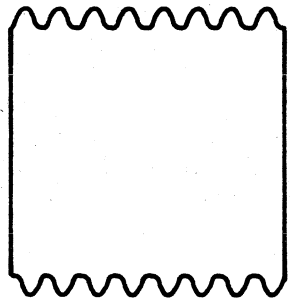

E10

Same as above. Sideband suppression 20 db.

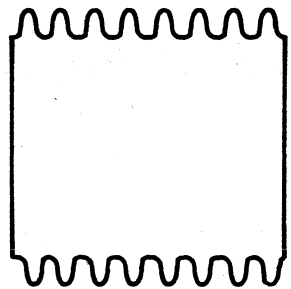

E11

SSB signal, tone input. Poor suppression. May be due to audio unbalance, or RF phase shift is not 90° .

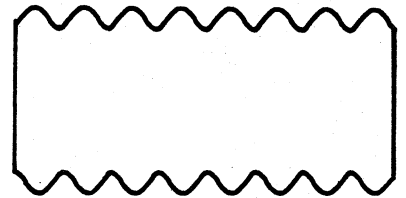

E12

SSB signal, tone input. Carrier leakage. Note this pattern has half the number of ripples as the pattern above.

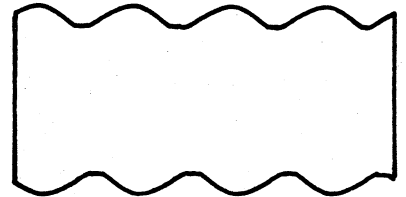

E13

SSB signal, tone input. Spurious radiation about 20 db. down.

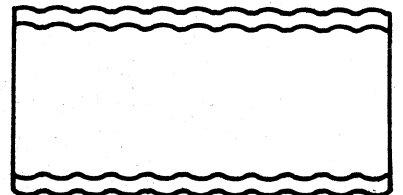

E14

SSB signal, tone input. Spurious radiation about 10 db. down.

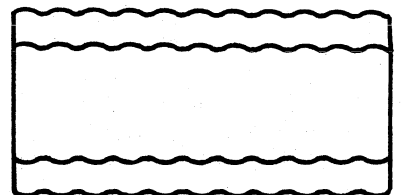

E15

SSB signal, tone input. Distortion in audio oscillator or audio system.

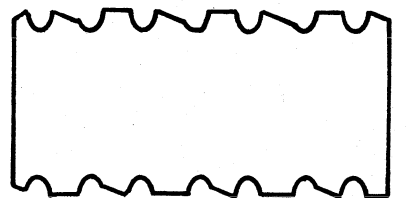

E16

SSB signal, tone input. Balanced modulator detuned, or insufficient RF in balanced modulator

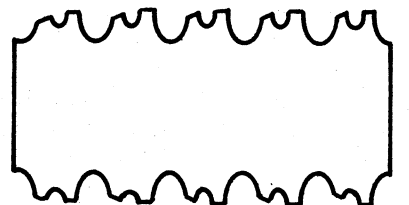

E17

SSB signal, tone input. Very little sideband suppression. Caused by defective modulator tube; audio phase shift network; 90° RF phase shift component; partially shorted modulation transformer; secondary of transformer that feeds audio phase shift network shorted to ground; master crystal oscillating on two adjacent frequencies simultaneously. On Multiphase Models 10 and 20 Exciters, L2 seriously misaligned.

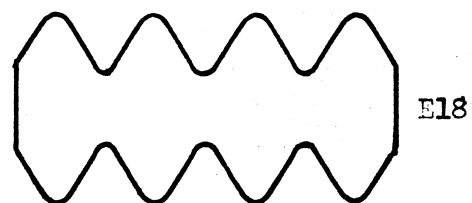

SSB signal, tone input. No sideband suppression. One modulator tube dead; modulation transformer open or shorted.

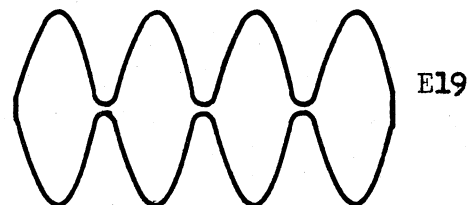

SSB signal, tone input. Amplifier flattening due to excessive RF drive. Note lack of fine ripple on the envelope.

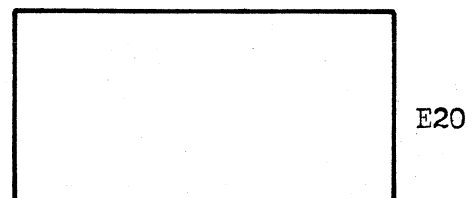

Double sideband without carrier, or single sideband with carrier 100% modulated, tone input. This may be used for a "Two Tone Test." Excellent waveform.

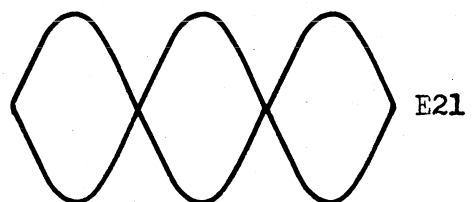

SSB with carrier, tone input. Incorrect value of carrier or modulation.

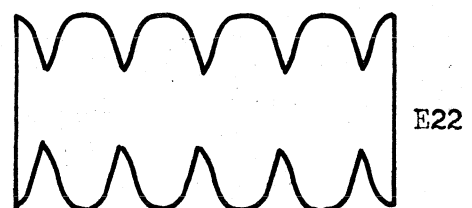
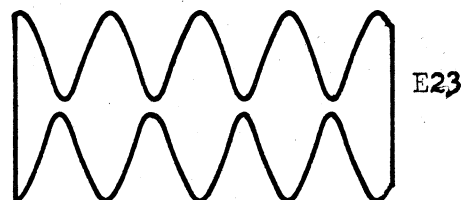
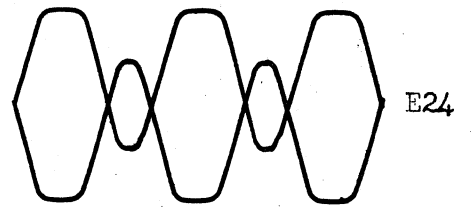

Plate modulated AM, or double sideband with carrier inserted, tone input. 100% modulated. Excellent waveform.



Double sideband with carrier inserted (low level AM), tone input. Overmodulated, too much audio gain.



Double sideband with carrier inserted (low level AM), tone input. Too much carrier inserted. Note that the positive peaks flatten before a fine base line is obtained.

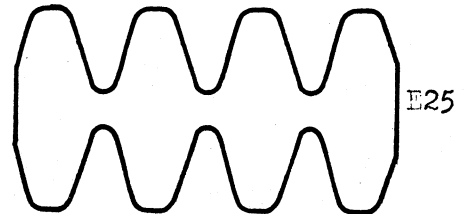

Double sideband with carrier inserted (low level AM), tone input. Insufficient carrier insertion, resulting in high distortion. Also called Double Sideband Reduced Carrier (DSRC).

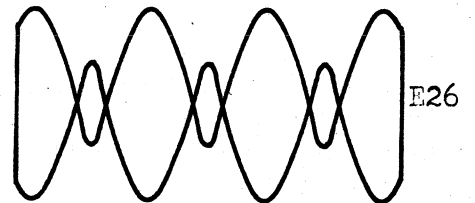

Low or high level AM. Extremely strong positive peak parasitics.

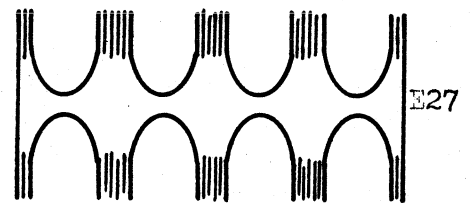

Low or high level AM. Strong positive peak VHF parasitics.

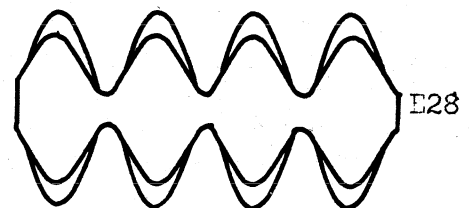

Low or high level AM. Mild fundamental frequency parasitics.

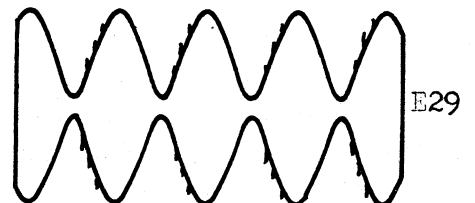

Double sideband without carrier, tone input. Carrier leakage through working modulator. In Multiphase Models 10 and 20 Exciters, carrier null potentiometer "A" unbalanced.

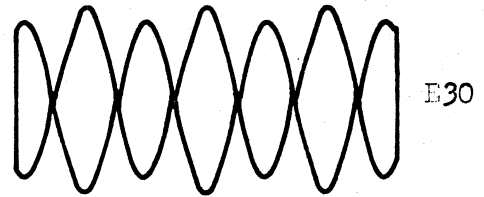

Double sideband without carrier, tone input. Carrier leakage through disabled modulator. In Multiphase Models 10 and 20 Exciters, carrier null potentiometer "B" unbalanced.

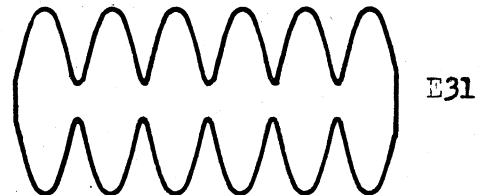

Double sideband without carrier, tone input. Peaks flattened due to excessive AF or RF drive, insufficient interstage loading, or insufficient antenna coupling.

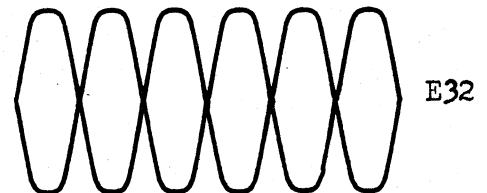

Low or high level AM, tone input. Severe distortion in modulator system or AF tone generator. RF feedback to audio system, or RF feedback to previous low level stage.

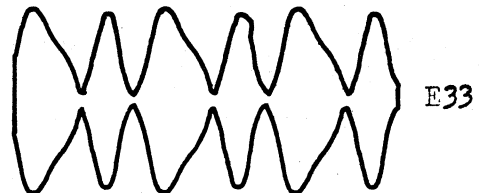

Nonlinearity in modulated RF stage, due to insufficient excitation of a plate modulated stage or overdrive to a grid modulated stage. Insufficient antenna loading of a grid modulated stage.

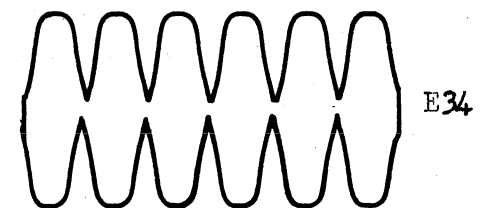

Plate modulated AM, tone input. Insufficient modulator output. Modulation in excess of 100% in downward direction.

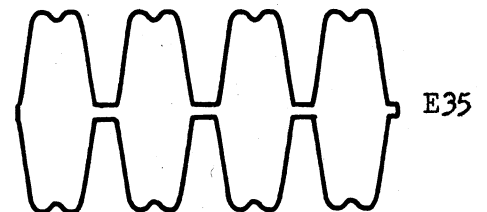
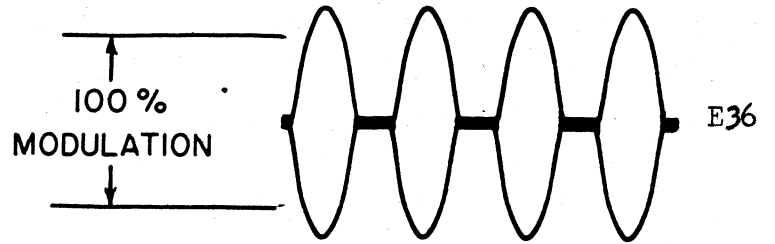

Plate modulated AM, tone input.
Modulator output more than ample.
Modulation in excess of 100% in
both directions.



DOUBLE TRAPEZOID OR BOW TIE PATTERNS

These require connection as shown in Figure C. They may be obtained by applying two audio tones simultaneously (or one audio tone plus carrier) to a SSB exciter, or a single tone to a phasing type exciter in the AM position with the carrier balanced out.

Good linearity. Desired pattern.

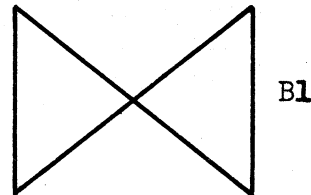

Peaks slightly flattened. Caused by overdrive or insufficient antenna loading.

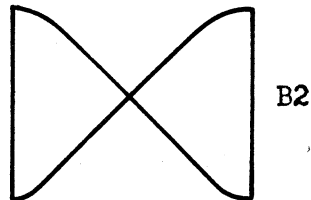

Peaks severely flattened, due to overdrive.

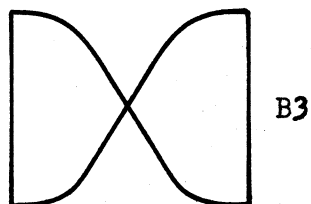

Carrier leakage through working modulator. On Models 10 and 20 Exciters, carrier null potentiometer "A" unbalanced.

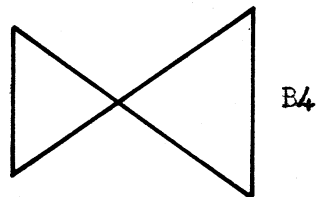

Carrier leakage through disabled modulator. On Models 10 and 20 Exciters, carrier null potentiometer "B" unbalanced.

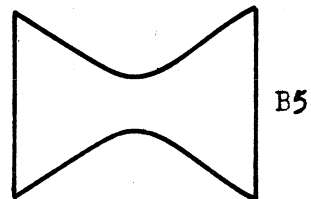

Grid current curvature. Note the slight departure from linearity at the point where the tube draws grid current.

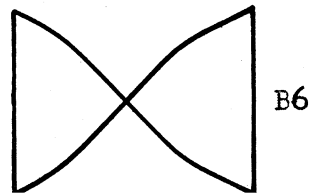

Grid bias curvature. Caused by excessive bias, or by operating some types of tubes with high plate voltage and high bias. May also be due to regeneration, or imperfect neutralization.

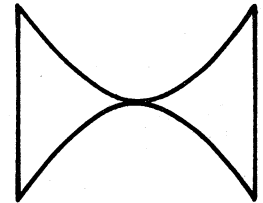

B7

Extreme grid bias curvature. Same as above.

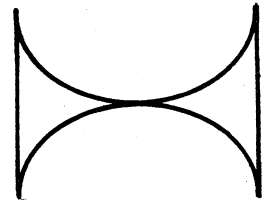

B8

Non linearity due to overdrive, or by excessive degeneration.

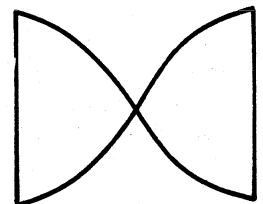

B9

Spurious radiation about 20 db. down. Insufficient selectivity in RF circuits, allowing undesirable beat products to pass through.

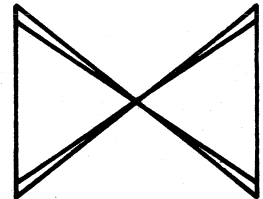

B10

Parasitic oscillation.

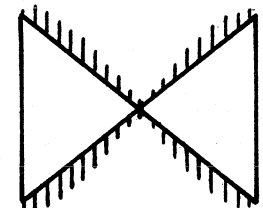

B11

Severe parasitic oscillation.

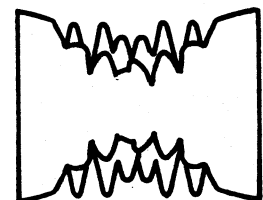

B12

TRAPEZOID PATTERNS

Plate modulation, single or double sideband with carrier, or RF trapezoid. Good linearity. Desirable pattern.

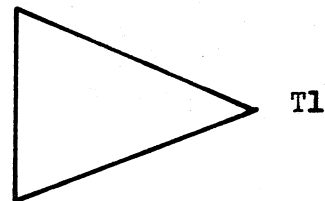

Plate, grid, or cathode modulation; double sideband or SSB with carrier. Modulation less than 100%. No distortion.

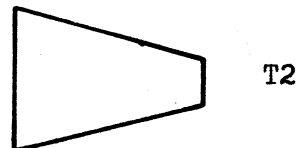

Non linear. With plate modulation, indicates lack of grid drive. With grid modulation, SSB or DSB with carrier, or RF trapezoid through linear amplifier, indicates overdrive, insufficient antenna loading, or grid current curvature.

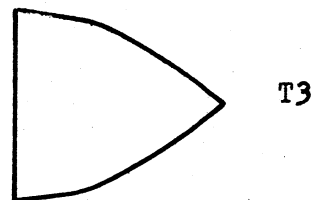

Plate modulation in excess of 100% in downward direction.

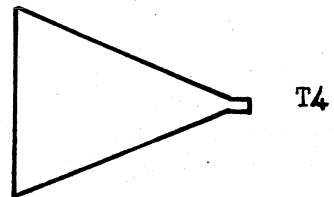

Plate modulation, severely overmodulated. Good modulator capability.

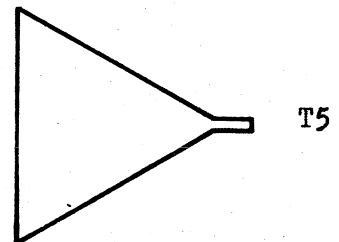
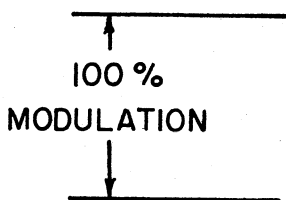

Plate modulation. Audio phase shift due to improper audio connection. Modulated approximately 80%.

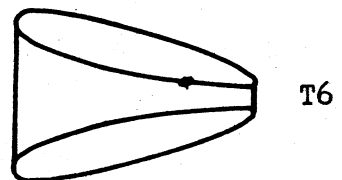

Plate modulation. Overmodulation in downward direction, with insufficient modulator capability.

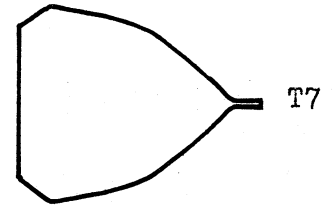
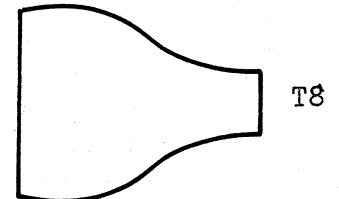
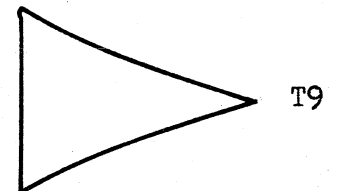

Plate modulation. Inadequate or mismatched modulator.



Non linear. With plate modulation this indicates regeneration due to improper neutralization. In linear operation this also indicates regeneration, or excessive grid bias.



Non linear. With plate modulation this is caused by insufficient driving power, or insufficient grid bias. In linear amplifiers this indicates regeneration or grid current curvature.

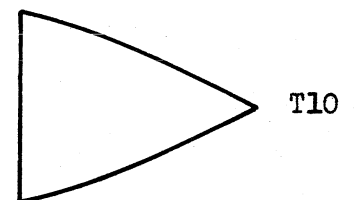

Positive peak parasitics.

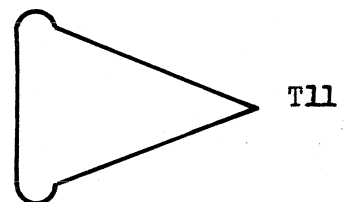

Screen grid or suppressor grid modulation, 100% modulated.

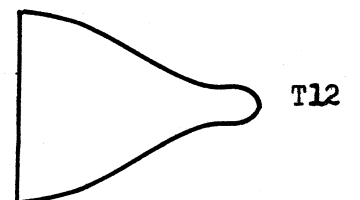

Grid modulation with improper neutralization and reactive lead.

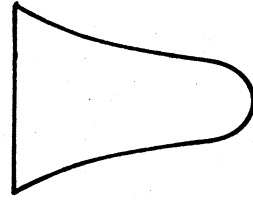

T13

Unmodulated carrier. Can be caused by:

No signal at Horizontal Deflection plates.
1 kc. test oscillator inoperative.
Gain control turned off on transmitter or oscilloscope.
Poor audio cable connection.
Audio failure in transmitter.



T14

