

ELENCO  PRECISION

AUDIO GENERATOR
SG-9200

SPECIFICATION

| | |
|------------------|-----------------------------------|
| Frequency Range | 10Hz – 1MHz, 5 decade bands. |
| Accuracy | $\pm 3\% + 2\text{Hz}$ |
| Output Impedance | 600 Ω , unbalanced |
| Output control | 0, -20dB, -40dB and Fine adjuster |

Sine Wave Output

| | |
|-------------------|---|
| Range | 10Hz – 1MHz |
| Output Voltage | 8 V. RMS. (Maximum) |
| Output Distortion | 100Hz – 10KHz Less than 0.05% 500Hz – 50 KHz Less than 0.5% 50 Hz – 500 KHz |
| Output Flatness | ± 1 dB (1KHz) |

Square Wave Output

| | |
|----------------|-------------------|
| Range | 10Hz – 10KHz |
| Output Voltage | 10V p-p Maximum |
| Rise Time | 0.5 μs |

Synchronization

| | |
|--------------------|---|
| Range | $\pm 3\%$ of oscillator frequency per V. RMS. |
| Input Impedance | 10K Ω , approx. |
| Maximum Input | 10V. RMS. |
| Power Requirement | 110V Or 220V AC 50Hz Or 60Hz |
| Dimension & Weight | 150(H) x 250(W) x 130(D) mm. approx. 2.5 kg. |

CONTROLS AND TERMINALS

1. **FREQUENCY Hz dial** For setting the output signal frequency.
2. **FREQ. RANGE switch** For selecting the frequency band:

| | |
|-------|------------------|
| x 1 | 10 – 100 Hz |
| x 10 | 100 – 1 KHz |
| x 100 | 1 KHz – 10 KHz |
| x 1k | 10 KHz – 100 KHz |
| x 10k | 100 KHz – 1 MHz |

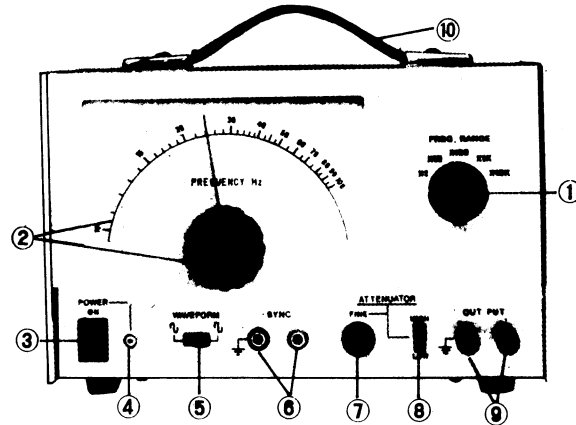

3. **POWER switch** For turning on the AC power.
4. **WAVEFORM switch** Selects the output signal waveform, sine or square.
5. **SYNC input** For connection to external frequency synchronizing signal.
6. **FINE Control** For continuous adjustment of output voltage.
7. **HIGH-LOW switch** Sets the output level; at LOW, output is lowered by 1/10 (20 dB).
8. **OUTPUT terminals** For lead connection of output signal to load; source impedance is approximately 600Ω.

OPERATION

1 Precautions in Use

1. The generator output should not be connected across circuits in which high DC or AC voltage is present. This is to prevent possible damage to the internal circuitry. When a DC voltage is present, connect a high grade capacitor, $20\mu\text{F}$ or more with ample voltage rating, in series with the "hot" lead.
2. The output connecting leads should be as short as possible to prevent pickup of unwanted noise. A long shielded cable will degrade the output response at high frequencies, especially when square waves are in use.
3. Make certain that the line voltage changeover switch at the rear of cabinet is at the proper setting for the AC line voltage in use.
The AC line voltage should be kept constant.

2 Interconnections

The basic interconnections are shown in Fig. 2-1.

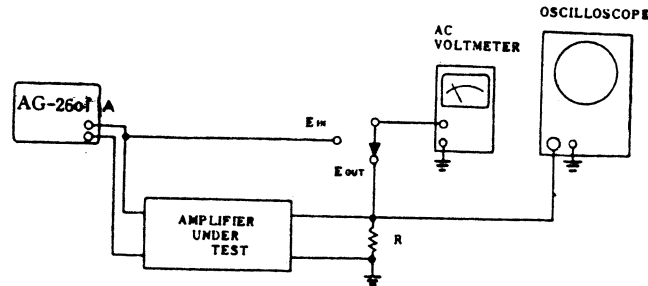

Fig. 2-1 Interconnections of the equipment.

The specified load resistance, R , is connected across the output of the test circuit. It should have a wattage rating of at least twice the expected maximum power output and be noninductive.

For measuring the input/output voltages, an electronic FET Voltmeter or VTVM, type is required. An oscilloscope is required during measurements with the square wave output signal.

3 Sine Wave Output

In most amplifier measurements, sine waves are used. In this section, directions will be given for typical applications.

A. Input/Output characteristic.

Control settings:

POWER switch at ON.

WAVEFORM switch at sine wave.

FREQ. RANGE switch at x 10 and dial at 100 for 1kHz.

OUTPUT switch initially at HIGH and FINE at fully counterclockwise.

Connect leads from the OUTPUT terminals to the input of the amplifier under test.

Advance the FINE control gradually. The output voltage will increase in proportion to the control setting.

When the amplifier is overloaded, there will be no apparent increase in the output voltage and the waveform distortion will be observed, usually flattening of one or both peaks of the trace.

The input and output voltages can be plotted on loggraph paper. In this manner, the input voltage range of the amplifier can be determined easily.

$$\text{VOLTAGE GAIN in dB} = 20 \log \frac{E_{\text{out}}}{E_{\text{in}}}$$

When the ratio E_{out}/E_{in} is determined, reference should be made to a decibel table for the dB figure.

The results for voltage gain in dB can be plotted on semilog graph paper using the X-axis for E_{in} and the Y-axis for dB.

The power output is calculated from the following:

$$\text{POWER OUTPUT, } P_o \text{ in WATTS} = \frac{E_{out}^2}{R \text{ ohms}}$$

B. Frequency Response

The frequency response of an amplifier is determined by applying a constant voltage. This voltage is chosen so that the amplifier is operated below the overload point.

Set the reference frequency at 1kHz, or 400Hz, and set the output controls for a suitable output from the amplifier.

Note the input and output voltages.

Set the measuring frequencies with the FREQ RANGE switch and dial from 20Hz or higher if required.

Since the generator output is practically constant at all frequencies, the input voltage will not require any adjustment. However for the highest accuracy, the input at each frequency can be adjusted to the predetermined value.

The output readings can be simplified by noting the output level in dB at the reference frequency (1kHz or 400Hz). Then at each frequency the dB indication is noted and used in plotting the response curve. (NOTE: Disregard the $0\text{dBm} = 0.775\text{V}$, etc, in this case. The dB readings can be read off directly since the voltmeter is connected across a constant impedance.)

The dB readings are added or subtracted from the 1kHz reference level.

Example: Let "dB" at 1kHz = -2dB . Assume that the measured values are as in (A) in the following data.

| FREQ (Hz) | 20 | 60 | 200 | 600 | 1K | 2K | 6K | 20K |
|--------------------|----|----|-----|-----|----|----|----|-----|
| (A) dB measured | -6 | -5 | -2 | -2 | -2 | -2 | -1 | -6 |
| (B) dB | -4 | -3 | 0 | 0 | 0 | 0 | +1 | -4 |

The dB figures (B) are used in plotting on a semilog graph paper with the X-axis for frequency and Y-axis for the relative response in dB.

In actual measurements, more frequency intervals than shown should be used.

4 Square Wave Output





Use of the square wave output is convenient in making rapid checks on amplifier performance. Various characteristics can be determined by observation of the output waveforms from the test amplifier on the scope.

The interconnections are identical with those for the sine wave operation with the following exceptions:

- a. WAVEFORM switch is set at square wave.
- b. Use of good scope is necessary, i.e. with fast rise time.

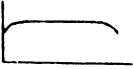
The chart below shows the conditions for the amplifier output waveforms.

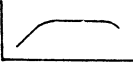
For an amplifier with good characteristics, the response will be flat up to about the 11th harmonic as indicated by a good square wave display. For example, if a square wave of 1kHz is reproduced without distortion, the amplifier response is flat to about 11kHz.

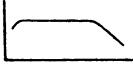
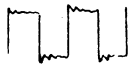
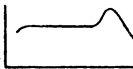
| Waveshape | Amplifier Response | Condition |
|--|---|---|
| RECTANGULAR  |  FLAT | SATISFACTORY |
| SAG  |  DEFICIENT LOW FREQUENCIES | LOW PRIMARY INDUCTANCE IN OUTPUT TRANSFORMER; INCORRECT VALUES OF THE COUPLING ELEMENTS |
| ROUNDING  |  DEFICIENT HIGH FREQUENCIES | HIGH LEAKAGE INDUCTANCE IN OUTPUT TRANSFORMER OR HIGH DISTRIBUTED CAPACITANCE IN CIRCUIT |
| RINGING  |  PEAKING AT HIGH FREQUENCY | MALADJUSTMENT IN THE NEGATIVE FEEDBACK CIRCUIT; INCORRECT CONSTANTS; INSTABILITY |

5 Use of the Synchronizing Feature

A. General:

It is to be noted that there are two voltages present at the SYNC. terminals, namely, about 2V DC and AC of about 0.8Vrms at the oscillator frequency. The "input" or "output" resistance is approximately 10kΩ. These conditions must be taken into account when connections are made to the terminals.

A few applications of the synchronous control will be given.

B. Control from an external source:

The frequency of the oscillator can be synchronized with an accurate source. It is possible to control the frequency over a range of $\pm 3\%$ with an input of 1Vrms.

For example, when the oscillator is set at some point between 970 and 1030Hz, then by applying a signal at exactly 1kHz, 1Vrms, the oscillator will be locked in automatically to 1kHz. Thus, high accuracy in the output frequency is achieved with use of a precision frequency standard. Excessive input voltages, however will distort the output waveform.

In another application, a highly distorted waveform can be purified or "filtered" by passing it through the oscillator.

It is possible to lock the oscillator frequency with the harmonics of distorted waveforms provided the amplitudes, are of sufficient magnitude; at low amplitudes, the control range is narrowed.

C. Control of external equipment:

The synchronous output voltage should be sufficient to operate a frequency counter, or to synchronize or trigger the sweep in a scope. The voltage available is not affected by the setting of the output controls.

6 Supplementary Notes on Operation

A. Load Impedance:

The load impedance of the generator should be 600Ω . When the load is higher or lower, use of a matching pad or transformer is advised.

For high impedances, say over $10k\Omega$, connect a 600Ω resistor in parallel with the load.

For low-power low-impedance circuits, connect a resistor in series with the load. The total impedance should be 600Ω .

B. Stereo input pad:

When testing stereo circuits, equal voltage to the two input circuits can be applied with use of a matching pad as shown in Fig. 2-2.

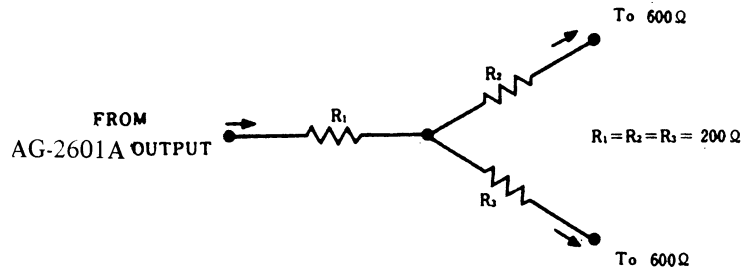

Fig. 2-2 Stereo input pad.

The voltage across the 600Ω loads at the outputs will be one-half that of the input voltage, or lower by 6dB.

C. Expositing the chassis:

The chassis can be exposed in the following manner for inspection:

1. Loosen two screws at front part of top cover.
2. Remove two screws on the bottom side.
3. Remove one screw at the back.
4. Take off the cover.

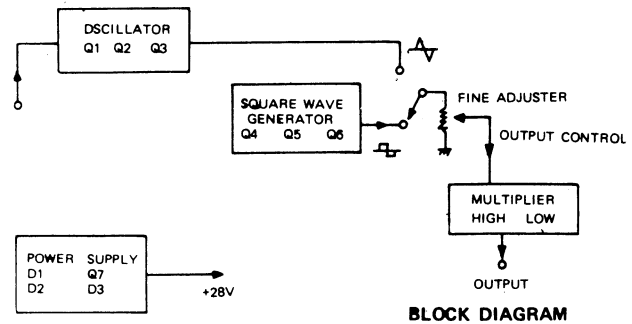

CURCUIT DIAGRAM

