

ASSEMBLY AND OPERATION OF THE HEATHKIT CONDENSER SUBSTITUTION BOX

MODEL CS-1



SPECIFICATIONS

Range.....	0.0001 μ fd through .22 μ fd
Voltage Rating.....	0.0001 μ fd through .00047 μ fd 500 volts 0.001 μ fd through .1 μ fd 600 volts 0.15 μ fd through .22 μ fd 400 volts
Switch.....	Eighteen-position Rotary Panel
Accuracy.....	0.0001 μ fd through .00047 μ fd \pm 5% 0.01 μ fd through .22 μ fd \pm 10%
Components.....	Silver Mica and Plastic Molded Tubular
Attachments.....	18" Flexible Leads with Alligator Clips
Dimensions.....	.5 5/16" long x 3 1/16" wide x 3" high
Shipping Weight.....	2 lbs.

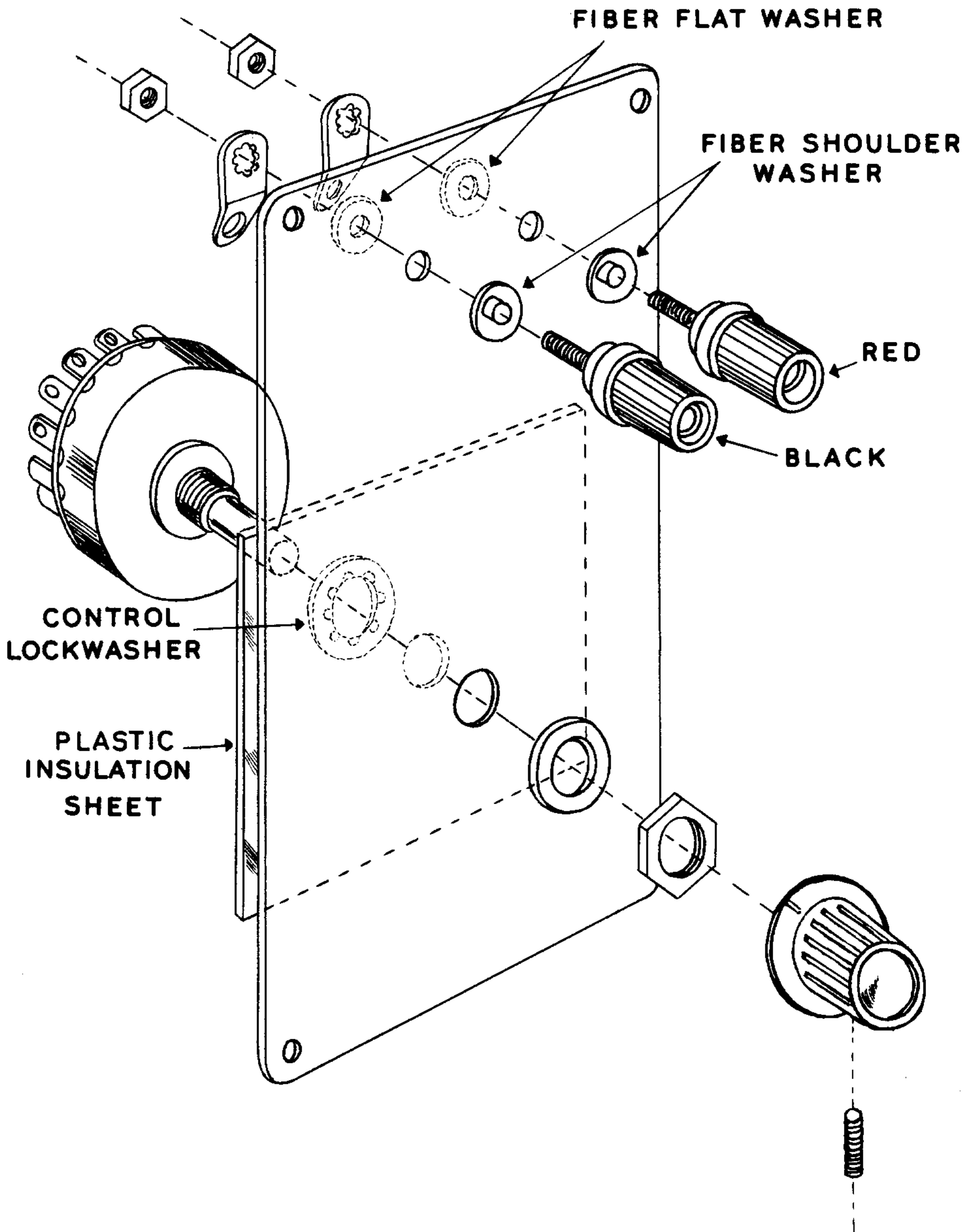

FIGURE 1

INTRODUCTION

The Heathkit Condenser Substitution Box will fulfill a multitude of requirements in service shops. It is provided for the quick determination of condenser values when working on electronic circuits of all types. Its usefulness will many times repay a little extra care devoted to its construction. Upon receiving the kit, carefully unpack it and check each part against the parts list. In this way you will become familiar with the various components and also will avoid throwing any parts away with the packing.

CONSTRUCTION

The construction of this kit is extremely simple. However, the notes below should prove helpful as they explain the method that was found to be the most convenient for wiring.

NOTE TO BUILDER: Throughout the step-by-step instructions, the following abbreviations will appear: (S) and (NS). These signs are used to facilitate construction. (S) means solder, (NS) means no solder. A convenient parenthesis will be found in the margin preceding each step. For your convenience, make a check mark in the parenthesis upon completion of each step. In that way, if it should become necessary for you to leave your work you will be able to determine exactly where construction was left off, upon resumption.

- () Mount the two binding post bases as indicated in Figure 1. Be sure the fiber shoulder and fiber flat-washers are in place. Slip the solder lug over the binding post base stud, place a 6-32 nut over the stud and tighten. The solder lug should be placed as indicated in Figure 1. Repeat this step for the other binding post base.
- () Turn the panel over so that the top or printed side is facing you. Place the red binding post cap on the right hand binding post base which is marked "HI". In a like manner, place the black binding post cap on the left hand binding post base marked "LO". Draw both of these caps up tightly with the finger, checking the binding post base to see that the 6-32 nut is secured in such a manner that the entire assembly does not turn when the binding post cap is secured.
- () Place the plastic insulation sheet under the large hole in the panel. Place the control lock-washer over the shaft located on the 18 position switch and slide through the hole in the plastic and panel. Next, slip a nickel control washer and control nut over the switch shaft and draw it up finger tight.

FIGURE 2

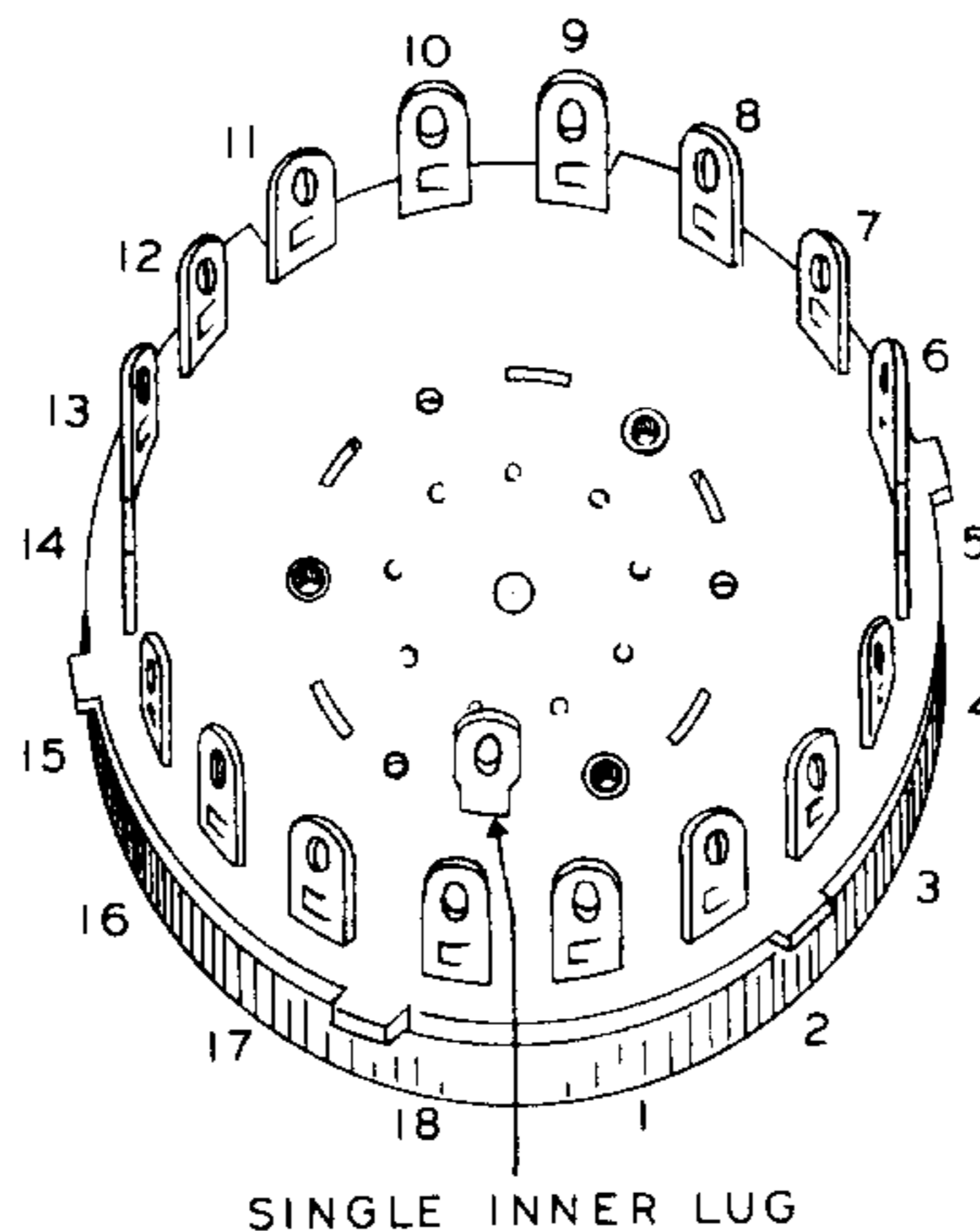

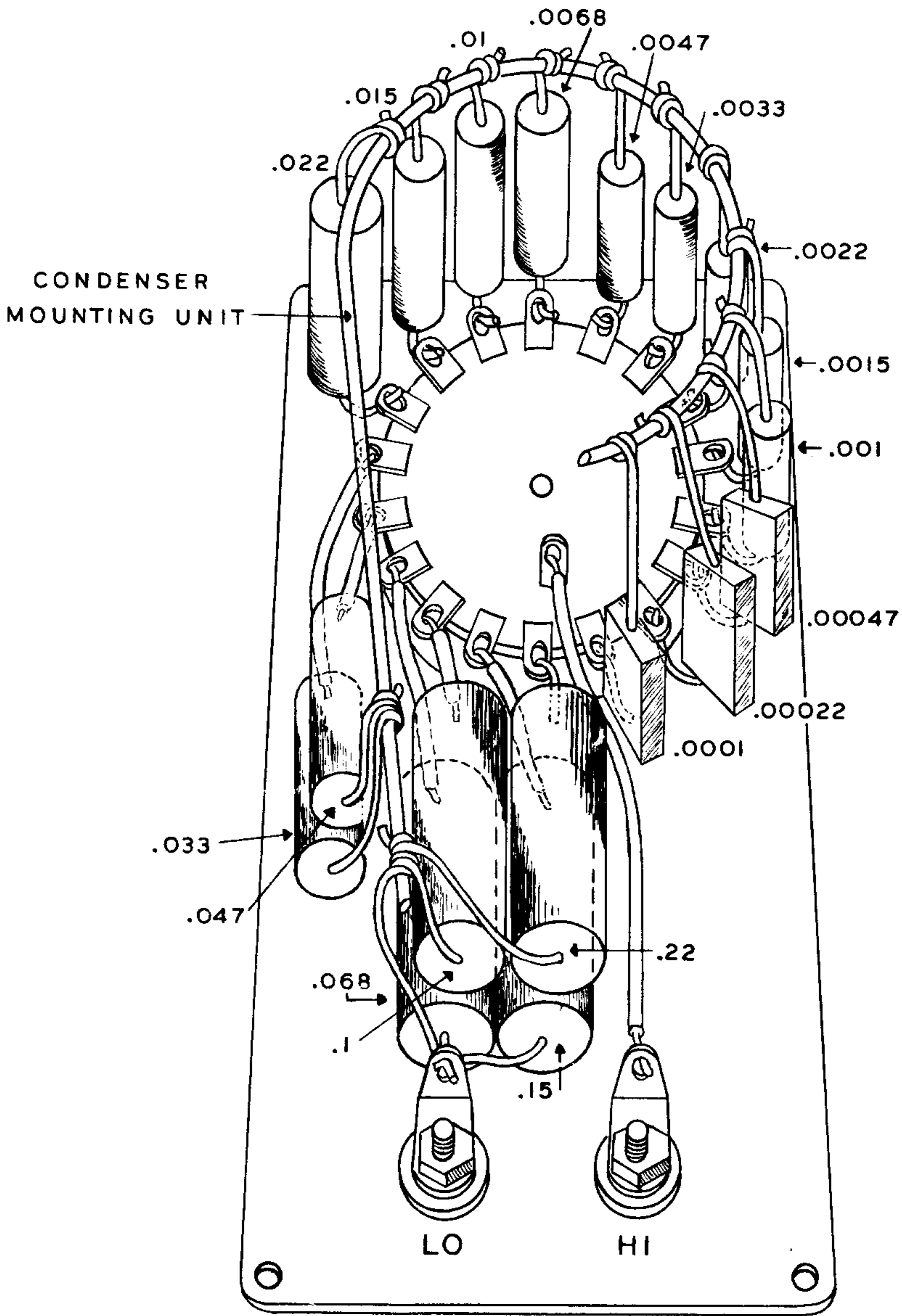

PICTORIAL I

- () Looking at the rear of the switch, orient it so that the lone inside lug is nearest the previously mounted insulated terminals. This is clearly shown in Figure 2. After orienting the switch, be sure the plastic insulation sheet is properly placed in respect to the panel and secure the control nut.
- () Using a pair of pliers, grip the shaft of the switch and turn the shaft in either direction. As will be seen, the contact wiper can easily be viewed from the side of the switch housing as it passes the various contacts. Rotate the shaft until the wiper is viewed at position 1. Refer to Figure 2 for correct contact location.
- () The pointer knob set screw is now installed in the pointer knob.
- () Without further turning the switch shaft, place the knob on the shaft and set the pointer to the .0001 position. Tighten the set screw on the shaft.

This completes mechanical construction.

The condensers supplied with this kit are of the plastic molded and mica types with standard tolerances. Mica condensers are identified by the RTMA color code while the tubular types are stamped with their actual value. Referring to the panel markings, these values can be individually chosen by rotating the switch to the desired position.

- () Bend all 18 lugs on the switch so that they are parallel to the panel. When mounting the condensers, you need not worry about polarity. If some of the tubular types have "outside foil" markings (dark colored band) they can be ignored.
- () To identify the mica condensers, notice that each has six colored dots arranged in two rows of three. Between the rows you will find a raised portion of the condenser body shaped like an arrow. Lay the condenser before you with the arrow pointing to the right. For this kit, only three of the dots are significant. The first is the center dot of the top row. The second is the dot just to the right of the first. The third is the dot just below the second. As an example, the .0001 μfd condenser will have significant colors of (brown-black-brown) which reads 100 $\mu\mu\text{f}$ or .0001 μfd .
- () Clip one lead of the .0001 μfd mica condenser to a length of 3/4". For detailed assembly refer to Pictorial 1. Bend the lead around as indicated and through the outside hole in the #1 terminal on the switch (S). The switch terminals are numbered in Figure 2.
- () Clip one lead of the .00022 μfd mica condenser (red-red-brown) to a length of 3/4". Bend it around and through the outside hole of the #2 terminal of the switch (S). Refer again to Pictorial 1.
- () In exactly the same manner, wire the .00047 μfd mica condenser (yellow-violet-brown) to lug #3 of the switch (S).
- () To aid and simplify construction, select the following tubular condensers, clip one lead to a length of 3/4" and lay them before you in this sequence: .001 μfd , .0015 μfd , .0022 μfd , .0033 μfd , .0047 μfd , .0068 μfd , .01 μfd , .015 μfd and .022 μfd . Now connect them to their respective switch terminals 4, 5, 6, 7, 8, 9, 10, 11 and 12. Solder each one in place.
- () At this point, examine the positions of the condensers mounted thus far. Make sure that the short leads do not touch the metal body of the switch. They should rest against the plastic insulation sheet previously installed. Refer to Pictorial 1 for details.

- () Now install the condenser mounting unit (heavy curved wire). Refer again to Pictorial 1 for proper positioning. Use the largest condenser of the group already installed (.022 μ fd) to determine proper distance between the switch and condenser mounting unit. One end of the condenser should press firmly against the plastic sheet and the body should point straight upward from the sheet. Clip the remaining lead of the condenser to a length of about 3/4". Place the condenser mounting unit over the condensers and wrap the short condenser lead around it. Do not solder. It is very important that the spacing between the condenser and the unit be no more than 1/8". Pictorial 1 is exaggerated in that respect.
- () Clip the long lead of the .0001 μ fd mica condenser attached to terminal #1 of the switch to a length of about 1". While holding the condenser mounting unit level, wrap this lead around it in the same manner. Do not solder. Notice that the smaller condensers will be spaced farther than 1/8" from the heavy wire.
- () Clip the remaining lead of the .00022 μ fd mica condenser to a length of 1". Wrap this lead around the condenser mounting unit as previously described (NS).
- () Clip the lead from the .015 μ fd condenser to a length of 3/4" and wrap it around the condenser mounting unit (S).
- () Check the positions of all condensers thus far installed and compare with Pictorial 1. When you are satisfied that each one is installed correctly and that the condenser mounting unit is mounted correctly, solder the three condensers previously attached to the unit.
- () Attach the remaining condensers to the mounting unit exactly as described and then solder all connections.
- () Strip 1/4" insulation from each end of the 3" hookup wire.
- () Attach one end of the hookup wire to the solder lug on the terminal post bearing the red terminal cap (S). Attach the other end of the wire to the single inner lug on the rotary switch (S). Allow the hookup wire to lie between terminals 1 and 18 on the switch.
- () Clip either lead of the .033 μ fd condenser to a length of 1" and slip a 3/4" length of sleeving over it. Now connect the short lead to the outside hole of lug #13 on the rotary switch (S). This condenser is to be positioned as shown in Pictorial 1. Place it parallel to and against the panel.
- () Prepare the .047 μ fd condenser in the same manner and connect the short lead to lug #14 of the switch (S). Place this condenser directly on top of the previously installed condenser and parallel to the panel.
- () In exactly the same manner, prepare the .068 μ fd condenser. Connect the short lead to lug #15 of the switch (S). Slide the other lead of this condenser through the top hole in the solder lug located on the "LO" terminal (NS). Place the condenser against and parallel to the panel and the two previously installed condensers. See Pictorial 1. Bring the remainder of the long lead up to the condenser mounting unit and wrap the end around the heavy wire (NS).
- () Clip one lead of the .1 μ fd condenser to a length of 1", use sleeving and connect this lead to lug #16 on the rotary switch (S). Place the condenser parallel to and directly over the one previously installed. Clip the other lead to a length of 3/4" and wrap it around the condenser mounting unit (NS).

- () Clip one lead of the .15 μ fd condenser to a length of 1 1/4". Use 1" of sleeving and connect the wire to lug #17 of the switch (S). Place this condenser parallel to and against the panel. Clip the other lead to a length of 3/4" and connect it to the "LO" terminal solder lug (S).
- () The last condenser, .22 μ fd is now installed by clipping one lead to a length of 3/4", sliding a 1/2" length of sleeving over the lead and connecting it to lug #18 of the switch (S). Cut the other lead to a length of 1" and wrap it around the condenser mounting unit (S).
- () Attach the loose leads of the condensers wired to switch terminals 13 and 14 to the condenser mounting unit (S).

This completes the electrical construction of the Condenser Substitution Box. Before proceeding further, check all solder connections to see that all connections are tight and that there is not an excessive amount of solder which could cause a short circuit between the switch lugs. Also make certain no bare wires from the condensers touch the bare metal panel or metal structure of the switch. Rotate the pointer knob throughout its entire arc to see that the switch is not jammed in any way. Make sure the nuts on the terminal studs are secure.

- () Place the panel on the plastic cabinet and secure with the four long 6-32 screws. Be careful not to exert excessive pressure when tightening these screws as damage might result to the plastic cabinet.

Refer to Figure 3 and prepare the test leads as follows:

- () Strip off 1/2" insulation from each end of the black and red test leads.
- () Place one end of each of these leads into the alligator clips (S).
- () The black test lead is assembled by connecting the black banana plug on the opposite end of the black wire. Slip the black insulator sleeve over the black lead; insert the stripped wire into the plug and wrap once around the plug, as shown. Screw the sleeve onto the plug securely. No solder is required.
- () The red lead is assembled in the same manner. The entire construction is now completed.

The voltage rating of the plastic molded and mica condensers furnished with this kit was mentioned previously. However, once again we should like to stress the voltage rating. The silver mica condensers carry a working voltage rating of 500. All other condensers with the exception of the .15 and .22 μ fd paper capacitors carry a rating of 600 volts. The .15 and .22 μ fd capacitors are rated at 400 volts. These ratings are all conservative and one need not be concerned with intermittent overloads of as much as 200%.

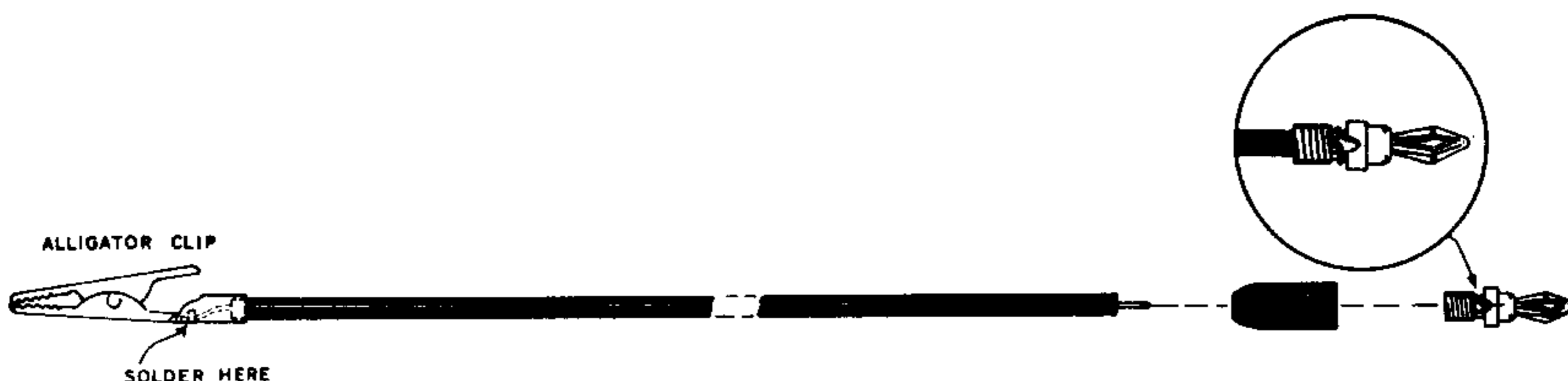

PART No.	PARTS Per Kit	DESCRIPTION
Condensers		
20-38	1	.0001 μ fd 500 v silver mica
20-39	1	.00022 μ fd 500 v silver mica
20-40	1	.00047 μ fd 500 v silver mica
23-35	1	.001 μ fd 600 v plastic molded paper
23-36	1	.0015 μ fd 600 v plastic molded paper
23-37	1	.0022 μ fd 600 v plastic molded paper
23-38	1	.0033 μ fd 600 v plastic molded paper
23-39	1	.0047 μ fd 600 v plastic molded paper
23-40	1	.0068 μ fd 600 v plastic molded paper
23-41	1	.01 μ fd 600 v plastic molded paper
23-42	1	.015 μ fd 600 v plastic molded paper
23-43	1	.022 μ fd 600 v plastic molded paper
23-44	1	.033 μ fd 600 v plastic molded paper
23-45	1	.047 μ fd 600 v plastic molded paper
23-46	1	.068 μ fd 600 v plastic molded paper
23-47	1	.1 μ fd 600 v plastic molded paper
23-48	1	.15 μ fd 400 v plastic molded paper
23-49	1	.22 μ fd 400 v plastic molded paper

Hardware

250-27	4	6-32 screw
252-3	2	6-32 nut
252-7	1	Control nut
253-1	2	#6 flat fiber washer
253-2	2	#6 fiber shoulder washer
253-10	1	Control nickel washer
254-4	1	Control lockwasher
259-1	2	#6 solder lug

Miscellaneous

63-38	1	18-position rotary switch
70-5	1	Black banana plug insulator
70-6	1	Red banana plug insulator
75-M12	1	Plastic insulation board
100-M16B	1	Black binding post cap
100-M16R	1	Red binding post cap
203-M57F70	1	Panel
213-M2	1	Condenser mounting unit
260-1	2	Alligator clip
344-1	1	length Hookup wire
408-M3	1	Plastic case
427-2	2	Binding post base
438-13	2	Banana plug
462-19	1	Skirted knob
341-1	1	Black test lead
341-2	1	Red test lead
346-1	1	length Insulating sleeving
595-78	1	Manual