

Heathkit of the Month:  
by Bob Eckweiler, AF6C



**TEST EQUIPMENT**  
**Heathkit IG-72**  
**Audio Generator.**

**Introduction:**

The IG-72 Audio Oscillator is a recent addition to my collection of practical Heathkits. Whenever I needed an audio oscillator in the past, I got out an old, but solid-state, Knight Kit KG-688. Though the Heathkit IG-72 uses tubes, it has some handy features. First, the output level is accurately adjustable and reads out on a large trapezoidal 4-1/2" wide max. x 4" high meter. Second, frequency selection is switch selected. Two significant digits of frequency can be selected by two eleven-position rotary switches and a multiplier switch of X1 through X1,000. The IG-72 is specified for a 5% accuracy over the range of 10 cps to 100 kc with less than 0.1% distortion between 20 cps and 20 kc.

The IG-72 was introduced in 1962 selling for \$41.95. It remained in production until 1977 selling then for \$64.95. It was replaced by the IG-18 solid-state Audio Oscillator. The IG-72 was one of the Heathkits that was available factory wired; in 1962 the wired version cost \$64.95 and in 1977 it cost \$100.

The IG-72 is a restyling of an earlier kit, the AG-9A. In Chuck Penson's Book *Heathkit Test Equipment Products*, Chuck classifies the Heathkit test equipment styling into six categories. The AG-9 and AG-9A are in the **Classic I** style and the IG-72 is in the **Classic II** style.

**The AG-9 Audio Generator:**

In the *Heathkits for 1956* catalog the AG-9 was listed as NEW. Prior to that time Heathkit had produced several audio oscillators, some with



Figure 1: Heathkit IG-72 Audio Generator

sine and square-wave outputs. However the AG-9 was the first audio generator that featured frequency selection by switch; it was also the first to feature a meter to display the audio output level.

The AG-9 sold for \$34.50 over its short 1 year lifespan. It was replaced with the AG-9A. The specifications of the AG-9 are shown in table I.

**The AG-9A Audio Generator:**

After a year of production, Heathkit came out with an updated version carrying the suffix 'A'. at the same \$34.50 price. The update involved some small circuit changes. One change is the screen resistor of the 6AU6 oscillator tube which was reduced from 150 KΩ to 120 KΩ. A second possible change involves the frequency selection resistors and possibly the rotary switch scheme. So far I've been unable to research this further.

The AG-9A (Figure 2) remained in production until 1962 finally selling for \$39.95 before it was restyled into the IG-72.

**The IG-72 Audio Generator:**

The IG-72 was the last of the tube audio oscillators produced by Heathkit. The IG-18 solid state oscillator came on the market a few years after the IG-72. It also features two-digit switch selection of frequency, but adds a vernier frequency control, and square-wave output capability.



Figure 2: Heathkit AG-9A Audio Generator

**Operation:**

Like its predecessors, the IG-72 has the same seven controls on the front panel. Three are for frequency selection, two are for setting level, one is for switching in an internal 600Ω load and the last is the AC power switch. The latter two controls are slide switches and the rest rotary switches and a pot. The controls are detailed in Table II.

Operation is not difficult. You select a frequency by dialing it in to the three switches. Say you want 2.6 kc at a level of -18 dBm . Using the **FREQUENCY** switches you set the first **CYCLES** switch to 20 and the second **CYCLES** switch to 6. Then you set the **MULTIPLIER** to **X100** (2,600). That is the frequency now being output (within the 5% tolerance). To adjust the output level, you set the **OUTPUT DB / VOLTS F.S.** switch to **-10 DB 0.3** [volts]. Adjust the meter using the **OUTPUT** potentiometer until the meter reads **-8 DECIBELS** which corresponds to 0.09 volts. If the output has a load of 600Ω (A common audio line impedance just as 50Ω is a common RF line impedance) you are all set. If you are driving into a high impedance load set on the internal **600Ω LOAD** switch before adjusting the level.

**IG-72 Circuit Description:**

The IG-72 audio generator is composed of five separate circuits (See Figure 4). The first is the

**AG-9 / AG-9A / IG-72 Specifications**

<b>Frequency:</b>	10 cps to 100 kc. Switch selected - 5% accuracy 2 significant figures & multiplier
<b>Output Ranges:</b>	0 - 10V, 0 - 3V into Hi-Z (10K min.) 0 - 1V, 0 - 0.3V, 0 - 0.1V, 0 - 0.03V, 0 - 0.01V and 0 - 0.003V into 600Ω
<b>Load:</b>	Internal 600Ω: 0 - 1V and below. (Switch selected)
<b>Meter:</b>	4-1/2" 200 uA. Three scales: 0 - 10V, 0 - 3V, -12dBm - +2dBm
<b>Distortion:</b>	Less than 0.1% 20-20,000 cps
<b>Tubes:</b>	1 - 6AU6, Oscillator 1 - 6CL6, Cathode Follower 1 - 6X4, Rectifier
<b>Power:</b>	105-125 VAC, 50-60 cps, 40 watts.
<b>Dimensions:</b>	9-1/2" W x 6-1/2" H x 5" D
<b>Weight:</b>	8 lbs. (shipping weight)

**Table I**

power supply. The second is the Bridged-T oscillator, and its frequency determining notch circuit. The third is a cathode follower. Also there are the attenuator and meter circuits.

**The Power Supply:**

At first I was surprised that the IG-72 uses a rectifier tube; selenium rectifiers were used in many Heathkit of the time. However the power supply puts out a high voltage at a moderate current draw so the 6X5 rectifier tube was the best solution prior to readily available silicon diodes. The power supply uses the 6X5 tube as a full wave rectifier producing 410 volts after a capacitor input LC filter. Filament voltage for the three tubes are provided by a 6.3 volt winding on the power transformer.

**The Cathode Follower Circuit:**

Perhaps discussing the cathode follower circuit is out of order at this time. However it provides two functions. First it drives the output from the oscillator, at a high level and low impedance, through the attenuator circuit to the out-

**AG-9 / AG-9A / IG-72 Controls**

Top Row From Left to Right

**[FREQUENCY] MULTIPLIER** Switch (4-pos. rotary)  
 X1, X10, X100, X1000  
 (Meter) **0 - 3 Volts R.M.S. scale**  
**0 - 10 Volts R.M.S. scale**  
**-12 dB - +2 DECIBELS (1 mW into 600Ω)**

**[OUTPUT]** (potentiometer) no nomenclature.

Second Row From Left to Right

**POWER OFF - ON** Switch (2-position slide)  
**600Ω LOAD INT - EXT** Switch (2-position slide)

Bottom Row From Left to Right

**[FREQUENCY] CYCLES** (11 position rotary switch)  
 0, 10, 20, 30, 40, 50, 60, 70, 80, 90, 100

**[FREQUENCY] CYCLES** (11 position rotary switch)  
 0, 1, 2, 3, 4, 5, 6, 7, 8, 9, 10

**[OUTPUT] DB / VOLTS F.S.** Switch (8-pos. rotary0)  
 -50 .003 **[600Ω LOAD]**  
 -40 .01 **[600Ω LOAD]**  
 -30 .03 **[600Ω LOAD]**  
 -20 .01 **[600Ω LOAD]**  
 -10 .3 **[600Ω LOAD]**  
 0 1 **[600Ω LOAD]**  
 +10 3 **[HI Z]**  
 +20 10 **[HI Z]**

(output) (Dual red / black 5-way binding posts)

Bold nomenclature is actual front panel nomenclature. Items in red brackets are a single nomenclature connected by red lines. Items in parentheses are for clarity.

**Table II**

put terminals. It also provides in-phase feedback to the oscillator section at a low impedance to maintain oscillation. This is a high power section and consumes most of the power used in the IG-72. A large 5,000Ω 20 watt load resistor acts as the load for the cathode follower and dissipates close to 10 watts.

The cathode follower consists of A 6CL6 pentode. Its plate is at 410V being connected directly to the output of the power supply and its

load consists of the 5 KΩ 20 watt resistor. A small 47 Ω resistor provides some cathode isolation. The grid of the 6CL6 is driven directly from the plate of the 6AU6 producing a low impedance representation of the oscillator's plate voltage at its cathode from which the oscillator feedback and output are taken.

**The Oscillator Circuit:**

A 6AU6 tube does duty as a bridged-T oscillator assisted by the 6CL6 cathode follower which we just discussed. Positive feedback is fed to the cathode of the 6AU6 from the cathode follower. This feedback is also fed to the grid of the 6AU6 after passing through a bridged-T notch network (Figure 3). This feedback, which is degenerative, prevents oscillation except at the notch frequency.

The regenerative feedback from the cathode follower to the oscillator's cathode is first fed through a voltage divider consisting of a tungsten lamp and an internally adjustable resistive **OSCILLATOR CONTROL**. This divider sets the feedback level to a point where oscillation is reliable. The tungsten lamp acts to stabilize the output level of the oscillator. Should the level increase, the lamp's resistance increases reducing the regenerative feedback and lowering the output level. The oscillator output is fed through the 5 KΩ front panel **OUTPUT** control to the attenuator and meter circuits.

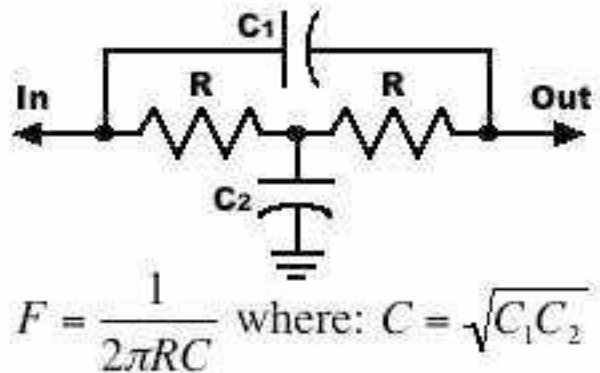

**Capacitor Shunted  
 Bridged-T Notch Network**

**Figure 3**

**The Oscillator Frequency Sub-circuit:**

The frequency of oscillator operation is determined by the notch circuit, whose equation is given in figure 3. The frequency selection scheme uses some clever switching to reduce the number of components required. Each decade requires two capacitors (C1 and C2 in figure 3), for a total of eight; The IG-27 uses just five. Also, each of the **CYCLES** switches uses eight resistors instead of twenty (The 'R's in figure 3). This saves a total of 27 components, 12 of which would be precision resistors and three of which would be semi-precision capacitors.

The five capacitors used for the four decades are; 0.5, 0.05, 0.005  $\mu$ F, 500 and 50 pF. They are used in adjacent pairs, resulting in a C of 0.159, 0.0159, 0.00159  $\mu$ F and 159 pF for the four decades. The orders of magnitude of the number 159 are important in electronics as 0.159 is approximately  $1/(2\pi)$ . Thus, from figure 3, the frequency for the four decades are (R is in K $\Omega$ ): 1,000/R, 10,000/R, 100,000/R and 1,000,000/R. Note that the frequency is inversely proportional to R, thus if R is halved, the frequency doubles.

The two values of R in figure 3 are always identical, and are determined by the resistances set by the two **CYCLES** switches. Since two 'R' resistors are needed for the circuit of figure 3, each **CYCLES** switch actually contains two identical 'R' circuits that switch simultaneously. Each R in figure 3 is the value of the resistances of one set of the two **CYCLES** switches in parallel.

The resistance of the tens decade **CYCLES** switch varies from 100 K $\Omega$  down to 10 K $\Omega$  and the resistance of the ones decade varies from 1 M $\Omega$  down to 100 K $\Omega$ . Each switch, in its zero position, is open.

As mentioned earlier, the frequency is inversely proportional to R. With the ones decade **CYCLES** switch at zero and out of the picture, and the **MULTIPLIER** switch set to X1 an R of 100 K $\Omega$  produces a frequency of 10 cps. Half of that (50 K $\Omega$ ) produces 20 cps, one third produces

30 cps, etc. All the values of the tens decade **CYCLES** switch are given in Table III. These 10 values for R can be made by the clever switching of four resistors also as shown in table III.

The ones decade **CYCLES** switch operates similarly except it uses the closest 5% resistance values to 1 M $\Omega$ , 500 K $\Omega$ , 333 K $\Omega$  and 250 K $\Omega$  (1 M $\Omega$ , 510 K $\Omega$ , 330 K $\Omega$  and 240 K $\Omega$ ). Since these resistors are at least an order of magnitude larger than the 1% resistors they shunt, they don't need higher precision.

**The Meter Circuit:**

The meter circuit measures the voltage at the wiper of the **OUTPUT** control. The AC signal is rectified by crystal diodes in a half-bridge configuration. A third crystal diode is used to compensate for the crystal non-linearity. The meter itself is 200  $\mu$ A full-scale with an internal resistance of 1.4K $\Omega$ . Meter calibration is set by an internal **METER CONTROL** potentiometer.

**Tens Decade CYCLE Switch Resistors**

Pos.	R	Resistors used for R
10	100.0 K $\Omega$	R1
20	50.0 K $\Omega$	R2
30	33.33 K $\Omega$	R3
40	25.0 K $\Omega$	R4
50	20.0 K $\Omega$	R1    R4
60	16.67 K $\Omega$	R2    R4
70	14.29 K $\Omega$	R3    R4
80	12.50 K $\Omega$	R1    R3    R4
90	11.11 K $\Omega$	R2    R3    R4
100	10.0 K $\Omega$	R1    R2    R3    R4

The symbol || means 'in parallel with'

This is how Heathkit was able to create the ten needed resistors using just four 1% precision resistors, R1 through R4 and some clever switching.

Table III

The meter has three scales. Two are voltage ranges of 0 to 10 and 0 to 3, and one is a dB scale of -12 to + 2 dBm. The scales are aligned so that each change of the attenuator results in a 10 dB change. Zero dBm is defined (and noted on the meter face) as 1 milliwatt into a 600  $\Omega$  load. This corresponds to 0.776 volts. Thus +10 dB corresponds to 2.45 volts and on the three meter scales 0, 2.45, and 7.76 align on the -12 to +2 dB scale, the 0 to 3V scale and the 30 to 10V scale respectively.

To read voltage use the scale and multiplier listed on the selected attenuator switch position. To read dBm use the dB scale and then add or subtract the dB listed on the selected attenuator switch position. As an example, say the attenuator is in the **-30 0.03 dB/V** position and the meter reads 1.4 on the 3 volt scale, 4.4 on the 10 volt scale and -5 on the dB scale. Since the attenuator is on the 0.03 volt position you can ignore the 10V scale and read the voltage on the 3V scale as 0.014 volts. Using the dB scale you add the -5 dB reading with the -30 attenuator position resulting in a reading of -35 dBm.

**The Attenuator Circuit:**

The attenuator has eight positions. Each step results in a change of 10 dB of attenuation, which is equivalent to a change in voltage by a factor of 3.16. These steps are created by a ladder network of voltage divider resistors.

The 10V and 3V outputs do not have the power to drive a 600 $\Omega$  load and thus are designed to run into a high impedance of 10K $\Omega$  or more. The remaining six attenuator positions are designed to operate into a load of 600 ohms. This can either be an external load or, if running into a high impedance, an internal 600 $\Omega$  load can be switched in. This load resistor, which is disabled in the 10 and 1 volt positions, actually is a 560 $\Omega$  resistor.

Accuracy of the level output depends upon the amount of attenuation and how well the output impedance matches the required output. At ten and three volts (the first two attenuator posi-

tions) the meter reading will be accurate if the impedance the generator is seeing is greater than 10 K $\Omega$ . On the remaining attenuator positions use the internal terminator if operating into an impedance of around 5 K $\Omega$  or more for best accuracy.

**Conclusion:**

I haven't had much experience using the IG-72 since I just acquired it. However, I was able to hook it up to a frequency counter and scope. The frequency readout was, in all cases, within specification (often well within!). The sine-wave output looked clean with no noticeable distortion, though I have no way to verify the 0.1% distortion specification. I'm looking forward to using it for some real experimenting soon.

**73, from AF6C**



**SIDEBAR:**

***Why KC and CPS?***

You way wonder why I'm using kc for kilo-cycles-*per-second* and cps for cycles-*per-second* instead of the more modern and correct kHz for kilo-Hertz and Hz for Hertz? the reason is for authenticity. These are the terms in use when the kit was first released and the manual printed in 1962. I've tried to do this throughout the series of Heathkit articles I've written, though I've probably erred somewhere!

***Bob, AF6C***

*This article originally appeared in the August 2014 issue of RF, the newsletter of the Orange County Amateur Radio Club - W6ZE.*

*Remember, if you are getting rid of any old Heathkit Manuals or Catalogs, please pass them along to me for my research.*

***Thanks - AF6C***

Figure 4

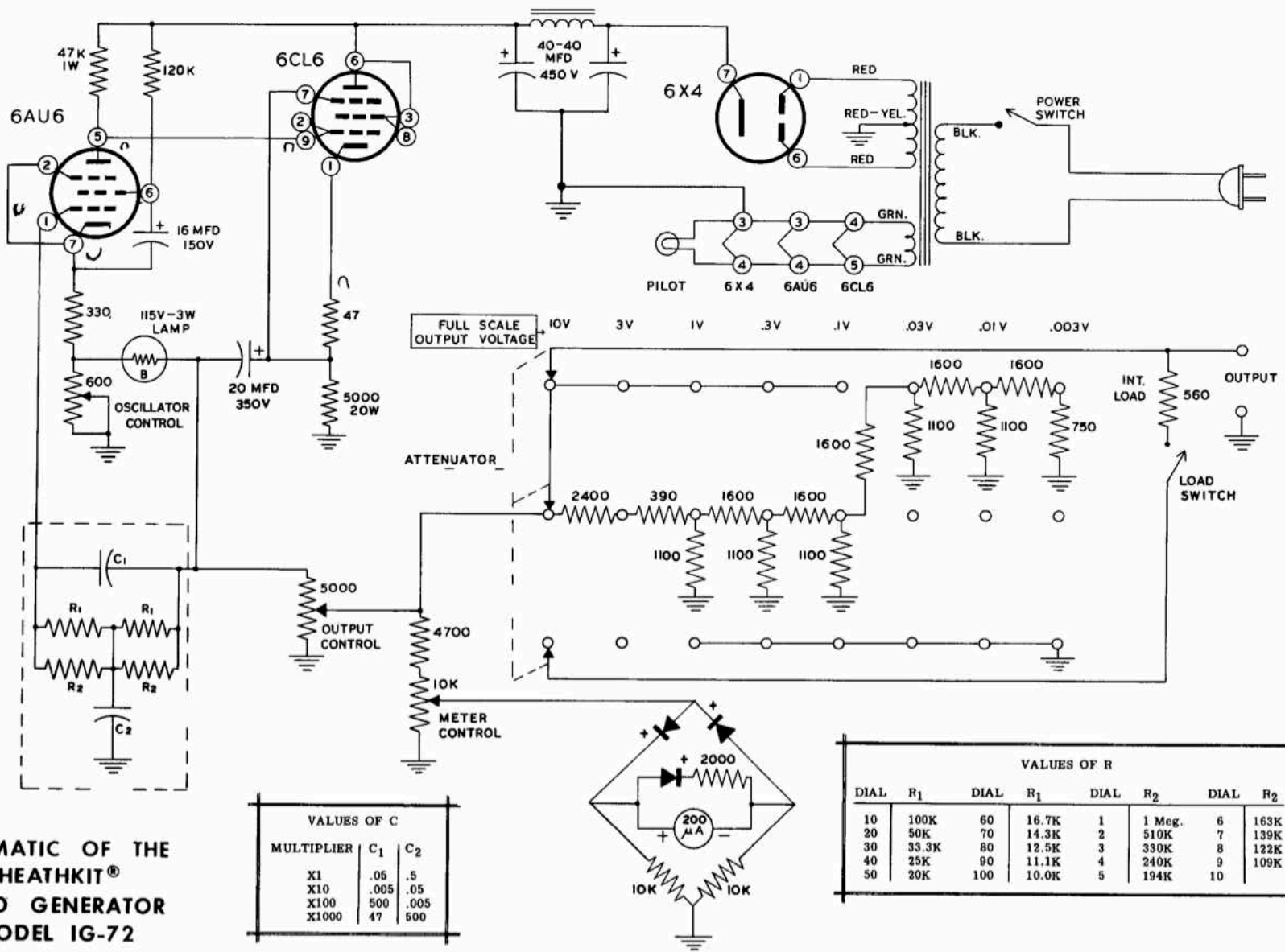

**SCHEMATIC OF THE  
HEATHKIT®  
AUDIO GENERATOR  
MODEL IG-72**

VALUES OF C		
MULTIPLIER	C <sub>1</sub>	C <sub>2</sub>
X1	.05	.5
X10	.005	.05
X100	500	.005
X1000	47	500

VALUES OF R							
DIAL	R <sub>1</sub>	DIAL	R <sub>1</sub>	DIAL	R <sub>2</sub>	DIAL	R <sub>2</sub>
10	100K	60	16.7K	1	1 Meg.	6	163K
20	50K	70	14.3K	2	510K	7	139K
30	33.3K	80	12.5K	3	330K	8	122K
40	25K	90	11.1K	4	240K	9	109K
50	20K	100	10.0K	5	194K	10	