

PRICE \$2.00

IM-18

9700

HEATHKIT® ASSEMBLY MANUAL

2-1772-330

2198

3595
17325



VACUUM TUBE VOLTMETER

MODEL IM-18

249
1150

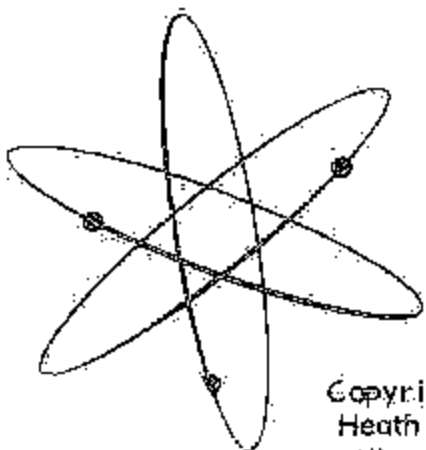











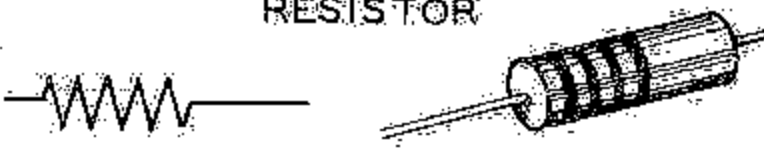

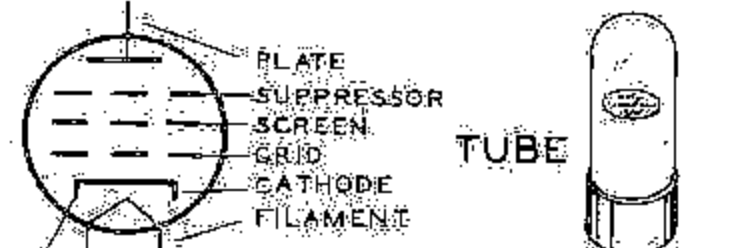

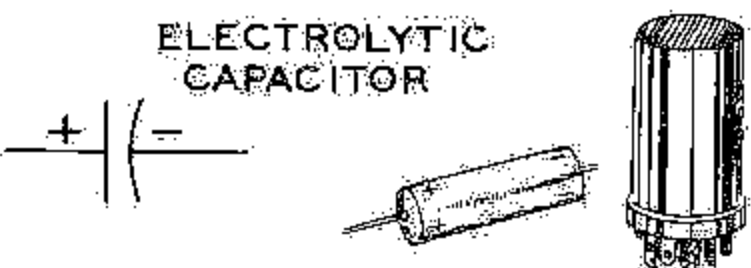

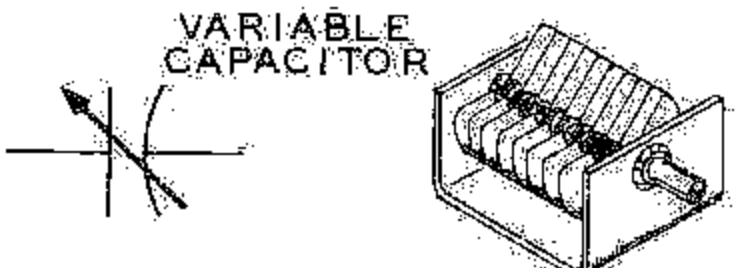

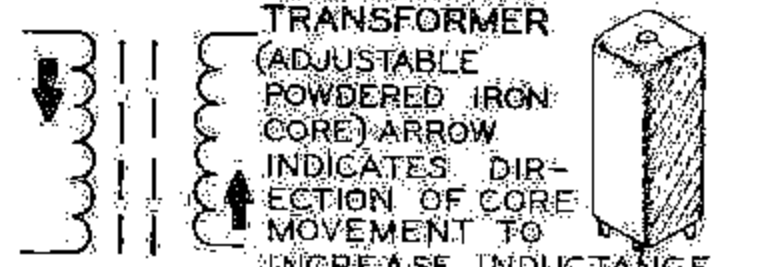
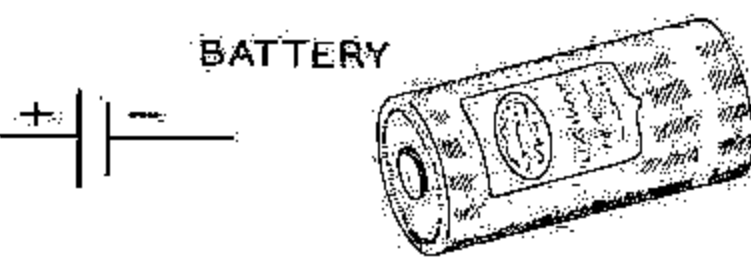
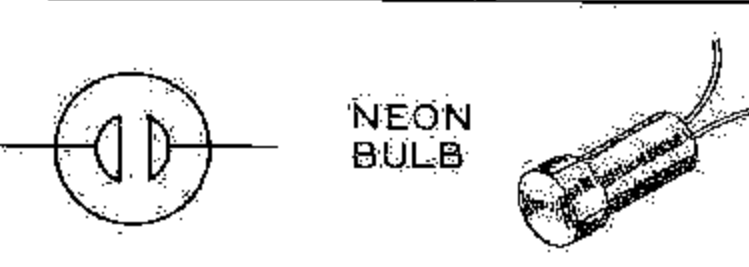
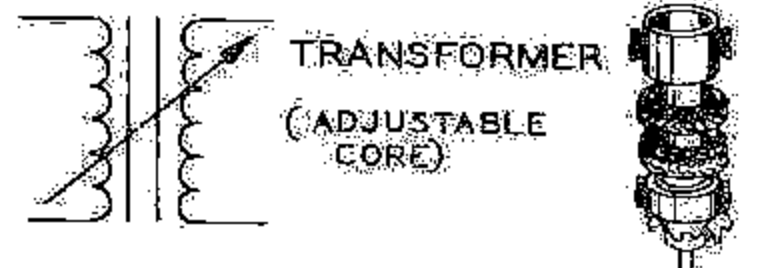
Copyright © 1968
Heath Company
All rights reserved.

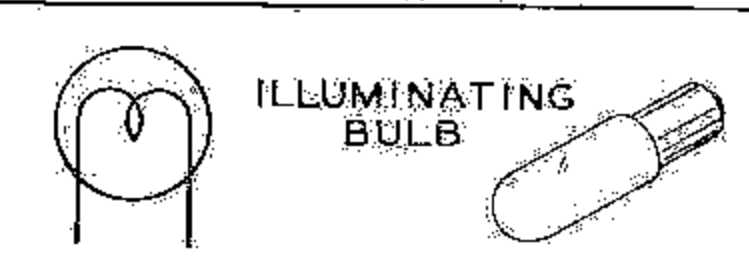
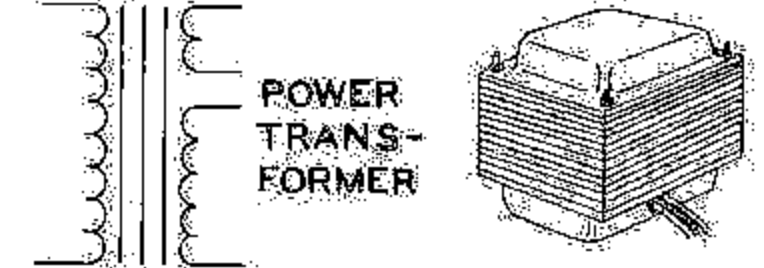
595-1154
6-6-69

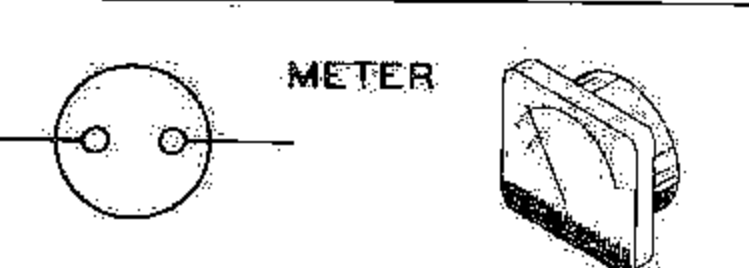
TYPICAL COMPONENT TYPES

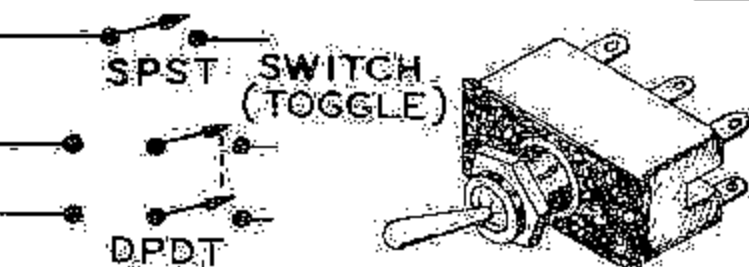
This chart is a guide to commonly used types of electronic components. The symbols and related illustrations

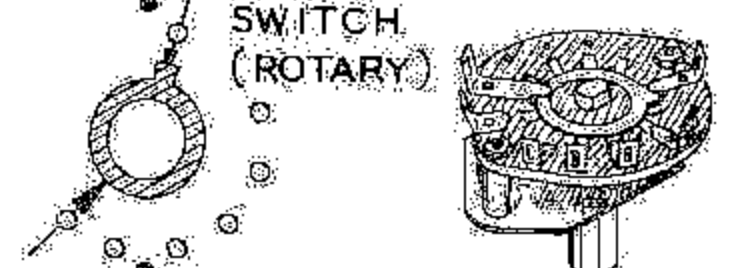
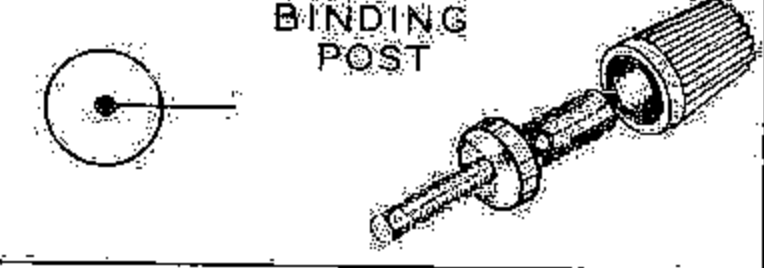
should prove helpful in identifying most parts and reading the schematic diagrams.

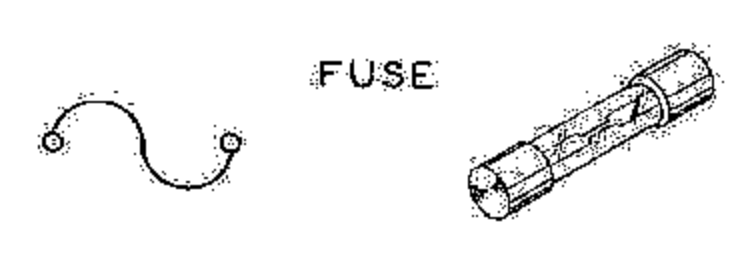
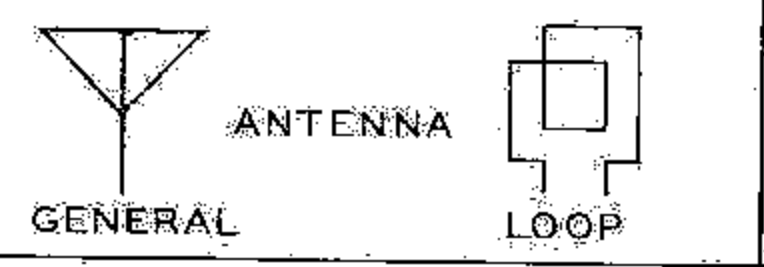
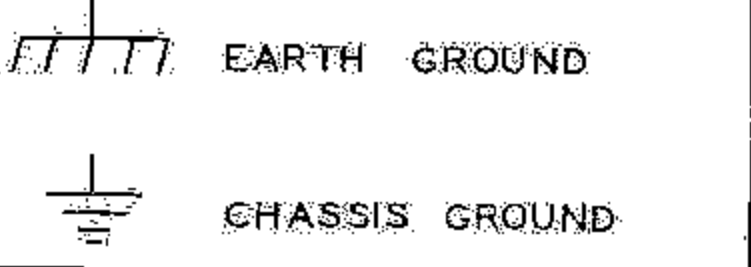
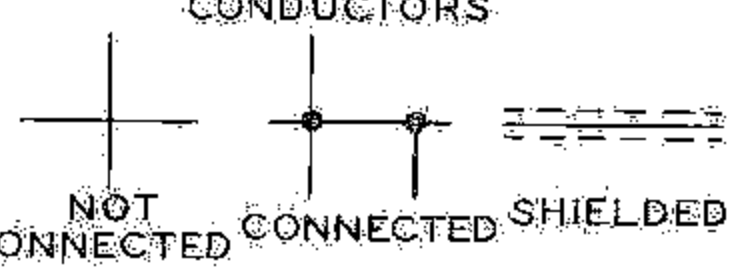
<p style="text-align: center;">RESISTOR</p> 	<p style="text-align: center;">CAPACITOR</p> 	<p style="text-align: center;">TUBE</p> 
<p style="text-align: center;">POTENTIOMETER (CONTROL)</p> 	<p style="text-align: center;">ELECTROLYTIC CAPACITOR</p> 	<p style="text-align: center;">TRANSISTOR</p> 
<p style="text-align: center;">TRANSFORMER (IRON CORE)</p> 	<p style="text-align: center;">VARIABLE CAPACITOR</p> 	<p style="text-align: center;">RECTIFIER (DIODE)</p> 
<p style="text-align: center;">TRANSFORMER (ADJUSTABLE POWDERED IRON CORE) ARROW INDICATES DIRECTION OF CORE MOVEMENT TO INCREASE INDUCTANCE</p> 	<p style="text-align: center;">BATTERY</p> 	<p style="text-align: center;">NEON BULB</p> 
<p style="text-align: center;">TRANSFORMER (ADJUSTABLE CORE)</p> 	<p style="text-align: center;">PHONE JACK</p> 	<p style="text-align: center;">ILLUMINATING BULB</p> 
<p style="text-align: center;">POWER TRANSFORMER</p> 	<p style="text-align: center;">PHONE JACK</p> 	<p style="text-align: center;">METER</p> 
<p style="text-align: center;">INDUCTOR (COIL)</p> 	<p style="text-align: center;">RECEPTACLE</p> 	<p style="text-align: center;">SPST SWITCH (TOGGLE) DPDT</p> 
<p style="text-align: center;">PIEZOELECTRIC CRYSTAL</p> 	<p style="text-align: center;">SPEAKER</p> 	<p style="text-align: center;">SWITCH (ROTARY)</p> 
<p style="text-align: center;">BINDING POST</p> 	<p style="text-align: center;">MICROPHONE</p> 	<p style="text-align: center;">FUSE</p> 
<p style="text-align: center;">ANTENNA GENERAL LOOP</p> 	<p style="text-align: center;">EARTH GROUND CHASSIS GROUND</p> 	<p style="text-align: center;">CONDUCTORS NOT CONNECTED CONNECTED SHIELDED</p> 

Assembly
and
Operation
of the



VACUUM TUBE
VOLTMETER
MODEL IM-18

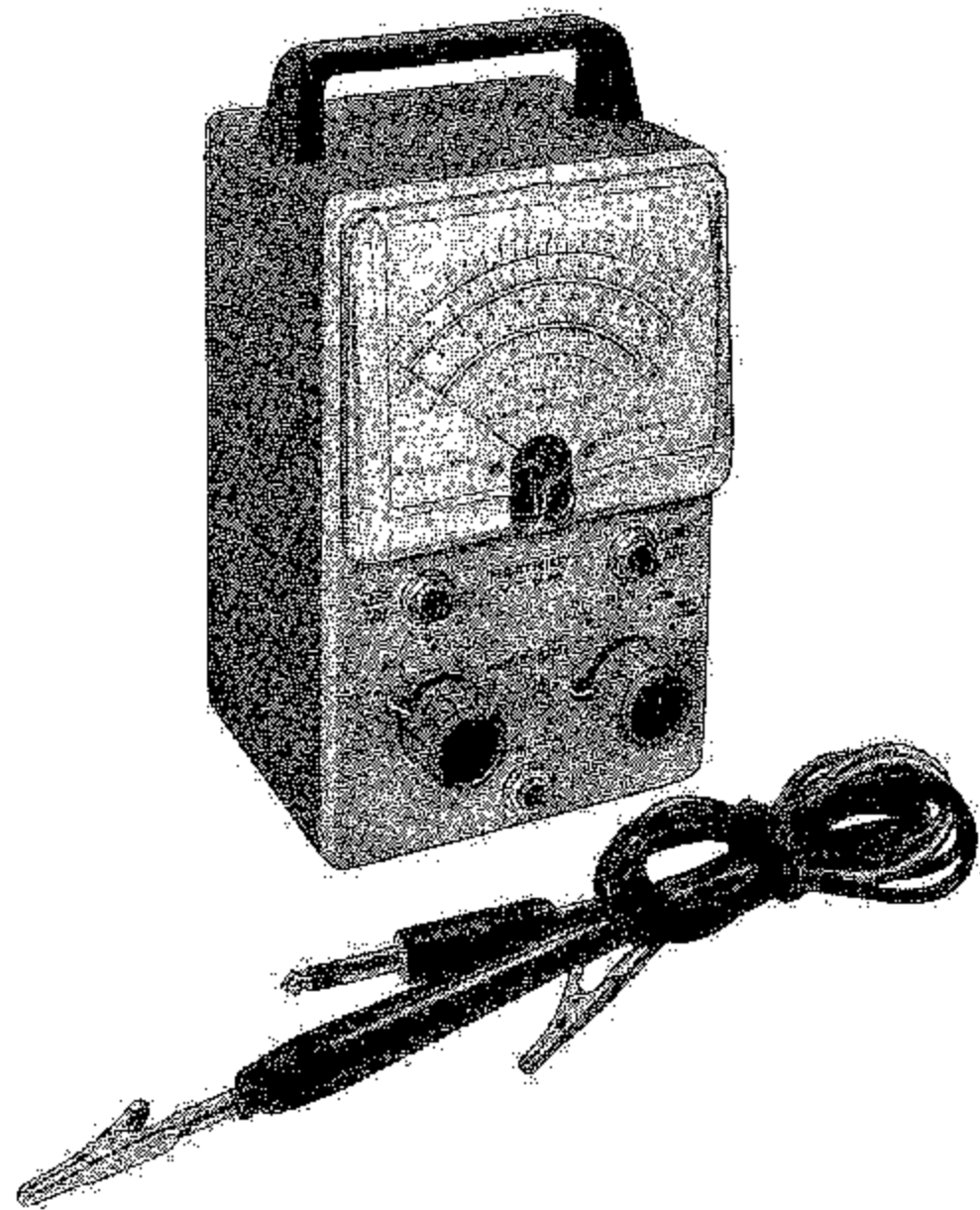

TABLE OF CONTENTS

Specifications.	2
Introduction.	3
Circuit Description.	4
Parts List.	5
Step-By-Step Assembly	
Range Switch Assembly.	7
Front Panel Mounting.	10
Knob Installation.	10
Front Panel Wiring.	11
Circuit Board Wiring.	12
Connecting Cable.	15
Wiring Circuit Board To The Panel.	15
Mounting The Battery Spring.	16
Meter, Bracket, And Circuit Board Installation.	16
Final Wiring.	17
Preliminary Test.	18
Preparation Of Test Probe And Leads.	20
Test And Calibration.	24
Using Your VTVM.	26
In Case Of Difficulty.	30
Troubleshooting Chart.	31
Maintenance.	32
Accessory Probes.	33
Schematic. . . . (fold-out from page).	33
Replacement Parts Price List.	34

HEATH COMPANY
BENTON HARBOR, MICHIGAN 49022



SPECIFICATIONS

Electronic DC Voltmeter-

7 Ranges.	0-1.5, 5, 15, 50, 150, 500, 1500 volts full scale; up to 30,000 volts with accessory probe.
Input Resistance.	11 megohms (1 megohm in probe) on all ranges; 1100 megohms with accessory probe.
Circuit.	Balanced bridge (push-pull) using twin triode.
Accuracy.	±3% full scale.

Electronic AC Voltmeter-

7 rms Ranges.	0-1.5, 5, 15, 50, 150, 500, 1500 volts full scale (.353 of peak-to-peak).
7 Peak-to-Peak Ranges.	0-4, 14, 40, 140, 400, 1400, 4000 volts full scale.
Frequency Response (5 V range).	±1 db 25 cps to 1 mc (600 Ω source).
Accuracy.	±5% full scale.
Input Resistance And Capacitance.	1 megohm shunted by 35 μuf (measured at input terminals).

Electronic Ohmmeter-

7 Ranges.	Scale with 10 Ω center X1, X10, X100, X1000, X10K, X100K, X1MEG. Measures .1 Ω to 1000 megohms with internal battery.
Meter.	4-1/2", 200 μa movement, polystyrene case.
Probes.	Combined AC-OHMS-DC switching probe, single jack input for probe and ground connections.
Dividers.	1% precision type.
Tubes.	1 - 12AU7, twin triode meter bridge. 1 - 6AL5, twin diode AC rectifier.

Battery.	1-1/2 volt "C" cell.
Power Requirements.	105-125 or 210-250 volts, 50/60 cps AC, 10 watts.
Cabinet Size And Finish.	7-3/8" high x 4-11/16" wide x 4-1/8" deep.
Net Weight.	3-1/2 lbs.

The Heath Company reserves the right to discontinue instruments and to change specifications at any time without incurring any obligation to incorporate new features in instruments previously sold.

INTRODUCTION

The HEATHKIT Model IM-18 Vacuum Tube Voltmeter is intended for use by servicemen, engineers, and maintenance men to make accurate measurements of DC+, DC-, AC rms and peak-to-peak voltages, plus resistance. The design is simple and rugged, yet accurate.

The instrument employs vacuum tubes for rectification and amplification on all measurement functions to insure good sensitivity and stability of operation. Precision resistors are used in the voltage divider networks to provide high accuracy.

The confusing tangle of test leads coming from the front panel of most VTVMs is eliminated by the use of a combination AC-OHMS-DC switching test probe and a single jack input connection for both test probe and ground leads. The 1 megohm resistor in the probe is switched into operation when the probe switch is set on DC. This isolating resistor allows DC component voltages to be measured separately, even when high frequency AC voltages are present at the test point.

The VTVM has a very high input impedance (11 megohms on DC and 1 megohm shunted by 35 $\mu\mu\text{f}$ on AC). Consequently, the circuit in which the voltage is being measured will not be significantly loaded by the VTVM. Most nonelectronic voltmeters (VOM) have a much lower input impedance over the most frequently used ranges of test voltages. Consequently, when a VOM is used to measure voltages in high impedance circuits, the indicated voltage will be appreciably less than the actual voltage. The amplifier section of the VTVM also enables the VTVM to accurately measure much higher resistances than can be conveniently measured with a VOM.

Read the "Kit Builders Guide" for complete information on unpacking, parts identification, tools, wiring, soldering, and step-by-step assembly procedures.

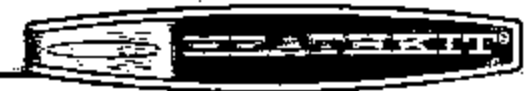

CIRCUIT DESCRIPTION

The combination AC-OHMS-DC test lead of the VTVM is connected to the Function switch, which is used to connect the part of the VTVM circuit needed for a specific measurement function. The COMMON test lead is connected to the case (ground) of the instrument.

With the Function switch in the DC+ or DC- position and the switching probe on DC, the test voltage is applied through the 1 megohm resistor in the probe to the Range switch, which is a series of precision resistors arranged as a voltage divider. Depending on the position of the Range switch, a portion of this DC voltage is "picked off" and applied to the input grid of the 12AU7 tube.

With the Function switch in the AC position and the test probe on AC-OHMS, an AC test voltage is applied to the 6AL5 tube (half-wave doubler circuit) where it is changed to a DC voltage which is proportional to the applied AC test voltage. On the higher AC ranges, a voltage divider arrangement is used at the input of the 6AL5 tube to insure that the AC voltage applied to the 6AL5 tube does not exceed the tube's rating. The DC voltage output of the 6AL5 tube is applied to the Range switch and then to the input grid of the 12AU7 tube, in the same way that DC test voltages are applied. A capacitor is used at the output of the 6AL5 to hold the applied pulsating DC voltage at its peak value, so that the VTVM responds to peak voltage regardless of the test voltage waveform. The AC balance control is used to "buck-out" the small amount of contact potential in the 6AL5 tube, thus eliminating residual readings on the lower AC ranges.

The ohmmeter section of the VTVM uses a 1.5 volt battery connected in series with part of the voltage divider network (determined by the Range switch position) and the resistance to be measured. The ratio between the ohmmeter voltage divider network resistors and the measured resistance determines what portion of the ohmmeter battery voltage is applied to the input grid of the 12AU7 tube.

Thus, for all measurement functions, a voltage dependent upon the quality being measured is applied to the grid of one-half of the 12AU7 twin triode. With zero voltage input to the 12AU7 bal-

anced bridge circuit, each of its triode sections draws the same amount of cathode current and therefore each cathode is at the same voltage potential. The meter movement is connected between the cathodes of the 12AU7 tube and consequently will not deflect since both cathodes are at the same potential.

When a positive voltage (from the Range switch) is applied to one-half of the 12AU7 tube, this half of the tube draws more current than the other half, causing a difference in cathode potential between the two tube sections. Since the meter is connected between the two cathodes, a current flows through the meter movement. The meter pointer responds proportionally to this current, indicating the value of voltage or resistance being measured. The DC+ and DC- switch positions are used to reverse the meter connections between the cathodes so that current always flows through the meter in the same direction.

The use of the bridge circuit eliminates any change in the voltage reading if the B+ voltage in the VTVM should vary since the resulting variation in tube conduction will occur in both triodes and, therefore, will not affect the difference in cathode potential. Also, the maximum conduction characteristic of the 12AU7 tube, as used in the VTVM circuit, is such that the voltage applied to the meter terminals cannot be large enough to damage the meter movement. This is one of the primary advantages of the VTVM circuit. The meter movement cannot be burned out by inadvertently measuring a voltage that is higher than the Range switch setting. However, if excessive voltage is applied, the pointer may be bent as it hits against the stop. Caution must also be exercised to avoid applying any test voltage to the test probe when the Function switch is set in the OHMS position. The precision resistors in the ohmmeter voltage divider network have very low power ratings and can easily be burned out in this way.

The power supply of the VTVM uses a silicon rectifier in a half-wave rectifier circuit. An electrolytic capacitor is used for filtering the DC voltage from the power supply. The power supply provides both B+ voltage for the 12AU7 tube and positive DC "buck-out" voltage for the AC balance circuit.

PARTS LIST

PART No.	PARTS Per Kit	DESCRIPTION
----------	---------------	-------------

RESISTORS

(1)1-3	1	100 Ω 1/2 watt (brown-black-brown)
1-20	1	10 K Ω 1/2 watt (brown-black-orange)
1-23	1	27 K Ω 1/2 watt (red-violet-orange)
1-27	2	150 K Ω 1/2 watt (brown-green-yellow)
1-29	1	220 K Ω 1/2 watt (red-red-yellow)
1-35	1	1 megohm 1/2 watt (brown-black-green)
1-38	1	3.3 megohm 1/2 watt (orange-orange-green)
1-40	1	10 megohm 1/2 watt (brown-black-blue)
1-70	5	22 megohm 1/2 watt (red-red-blue)
(2)3-4-2*	1	9.1 Ω 5% precision 2 watt (white-brown-gold-gold)

*NOTE: This Resistor is a 2 watt wire-wound resistor, but is the same size as a 1 watt composition resistor.

**2-24	1	90 Ω 1/2 watt precision
2-29	1	900 Ω 1/2 watt precision
2-35	1	9 K Ω 1/2 watt precision
2-50	1	10 K Ω 1/2 watt precision
2-38	1	20 K Ω 1/2 watt precision
2-9	1	70 K Ω 1/2 watt precision
2-41	1	90 K Ω 1/2 watt precision
2-86	1	150 K Ω 1/2 watt precision
2-54	1	200 K Ω 1/2 watt precision
2-87	1	320 K Ω 1/2 watt precision
2-13	1	700 K Ω 1/2 watt precision
2-51	1	900 K Ω 1/2 watt precision
2-55	1	2 megohm 1/2 watt precision
2-16	1	7 megohm 1/2 watt precision
2-52	1	9 megohm 1/2 watt precision
2-28-1	1	900 K Ω precision 1 watt

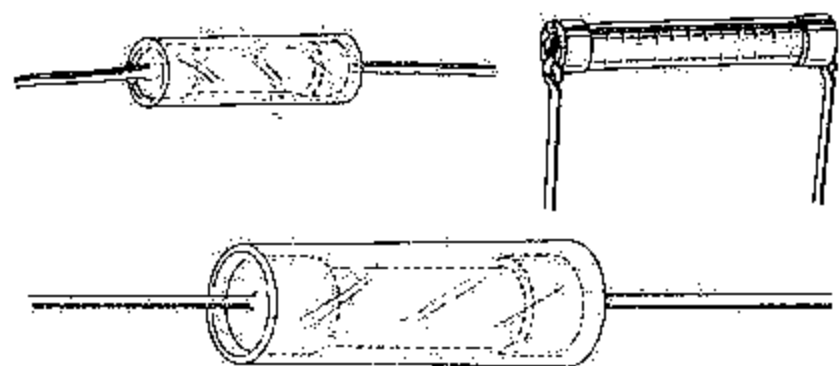

**Various shapes of precision resistors.

PART No.	PARTS Per Kit	DESCRIPTION
----------	---------------	-------------

CAPACITORS

(3)21-27	2	.005 μ fd 400 V disc ceramic
21-31	2	.02 μ fd 400 V disc ceramic
23-91	1	.047 μ fd 1600 V tubular
(4)25-5	1	16 μ fd 150 V electrolytic

CONTROLS-SWITCHES

(5)10-78	2	15 K Ω control
(6)10-38	3	10 K Ω control
63-500	1	Range switch
(7)63-501	1	Function switch

TUBES-LAMP

411-25	1	12AU7 tube
411-40	1	6AL5 tube
412-4	1	#50 pilot lamp

SOCKETS

434-47	1	Pilot lamp socket
(8)434-79	1	9-pin tube socket
434-112	1	7-pin tube socket

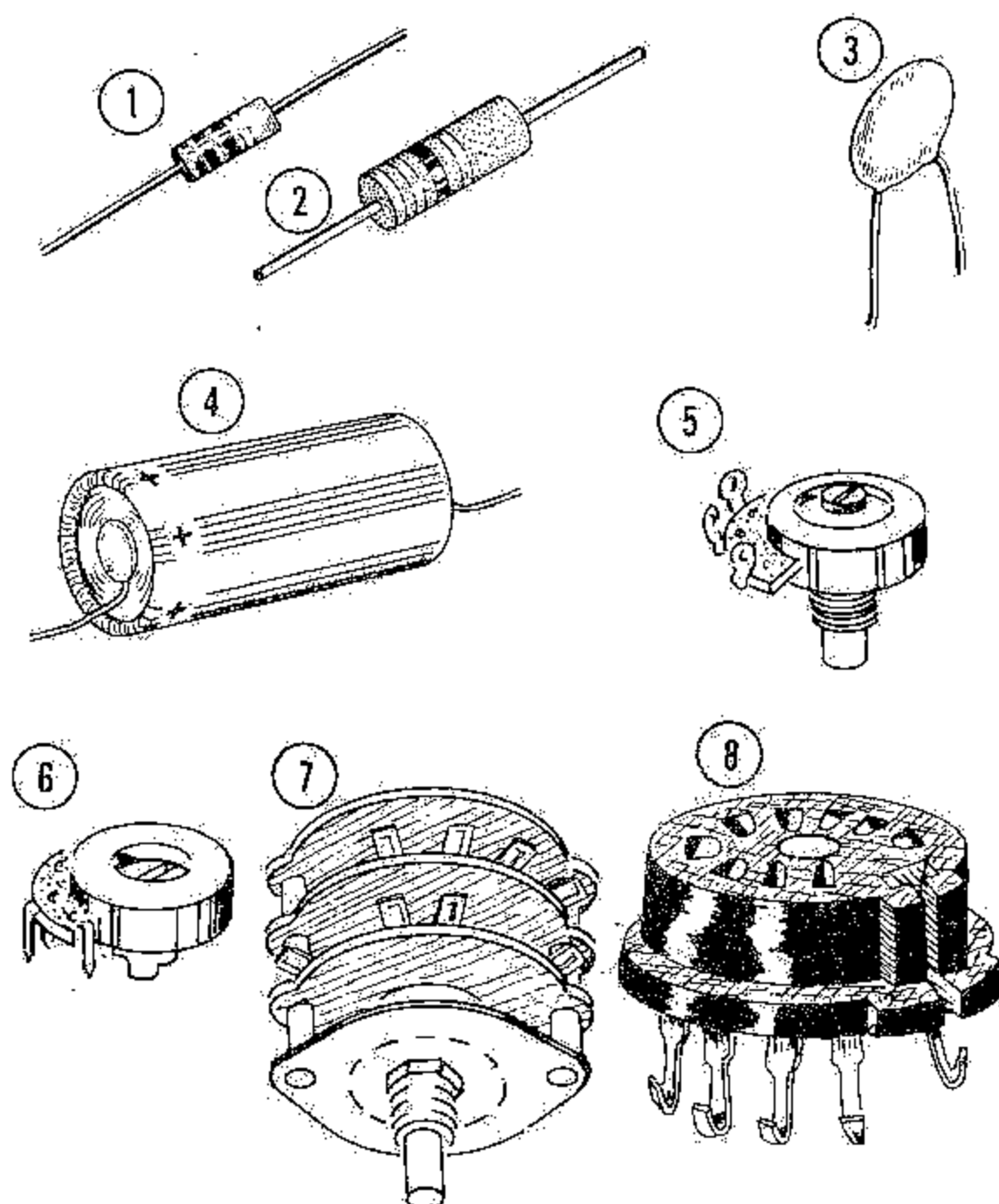



PART **PARTS** **DESCRIPTION**
No. **Per Kit**

WIRE-SLEEVING

89-23	1	Line cord
340-2	1	#20 bare wire
341-1	1	Length black test lead
343-11-1	1	Length shielded test lead
344-59	1	Length hookup wire
347-1	1	8-wire cable harness
346-1	1	Length insulating sleeving
346-6	1	Fiberglass sleeving

SHEET METAL PARTS

90-412	1	Cabinet and rear cover
203-278-2	1	Front panel
204-873	1	Bracket
214-2	1	Battery housing cap
204-84	1	Support bracket

HARDWARE

(1) 250-8	2	#6 sheet metal screw
(2) 250-89	3	6-32 x 3/8" screw
(3) 250-56	1	6-32 x 1/4" screw
250-83	2	#10 x 1/2" sheet metal screw
(4) 252-3	4	6-32 nut
(5) 252-7	5	Control nut
253-2	1	#6 fiber shoulder washer
253-3	2	#10 fiber flat washer
(6) 253-10	5	Control flat washer
(7) 254-4	5	Control lockwasher
(8) 254-1	4	#6 lockwasher
259-1	1	#6 solder lug

PROBE PARTS

(9) 253-51	1	E washer
(10) 256-15	2	1/16" x 1/8" rivet
258-53	1	Probe contact loading spring
(11) 459-6	1	Probe switch lever
(12) 459-7	1	Probe insert insulator
476-13	1	Front section of probe body
(13) 476-14	1	Center section of probe body
476-15	1	Rear section of probe body
(14) 477-7	1	Probe spike

PART **PARTS** **DESCRIPTION**
No. **Per Kit**

MISCELLANEOUS

54-23-24	1	Power transformer
(15) 57-27	1	Silicon diode
75-30	1	Strain relief, round line cord
(16) 75-71	1	Strain relief, flat line cord
85-9-1	1	Circuit board

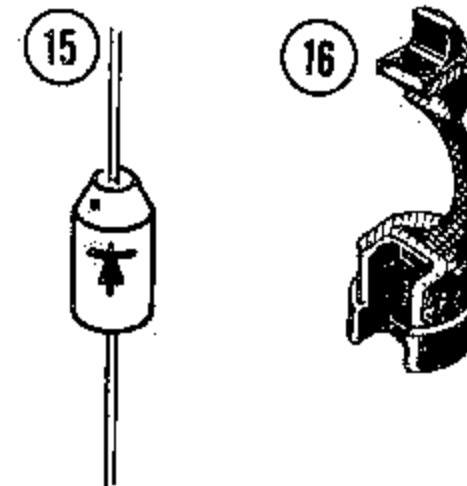
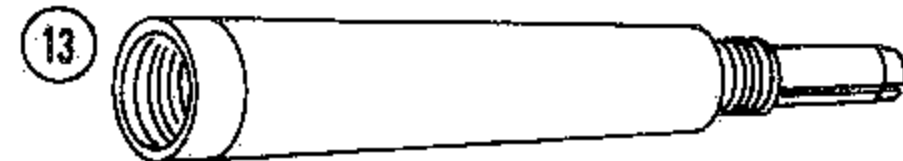
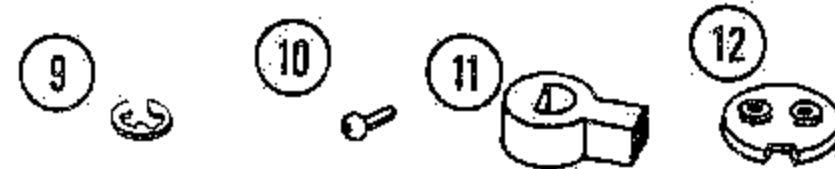
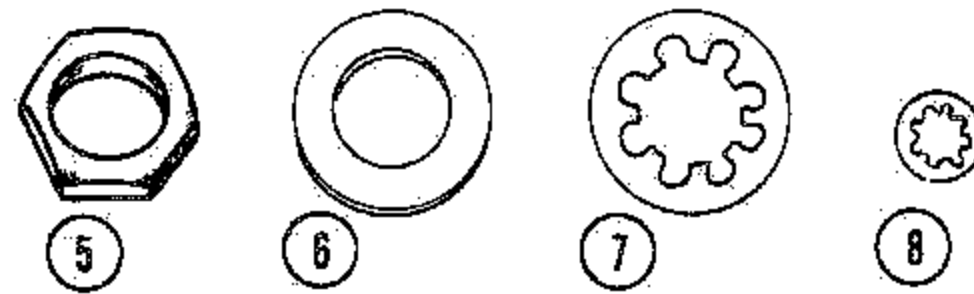
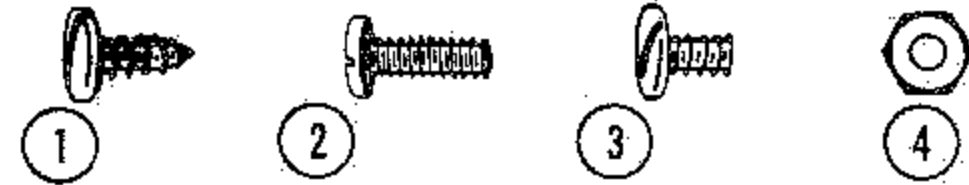



PART No.	PARTS Per Kit	DESCRIPTION
Miscellaneous (cont'd.)		
211-15	1	Handle
258-7	1	Battery spring
260-1	1	Alligator clip
260-51	1	Alligator clip with threaded insert
261-4	4	Rubber foot
407-62	1	200 microampere meter and hardware
432-27	1	Line cord adapter
(17) 432-67	1	Solderless connector
(18) 436-20	1	Phone jack
(19) 438-28	1	Phone plug
455-50	2	Knob bushing
462-245	2	Knob
391-34	1	Blue and white label
490-5	1	Plastic nut starter
597-260	1	Parts Order Form
597-308	1	Kit Builders Guide
	1	Manual (See front cover for part number.)
		Solder

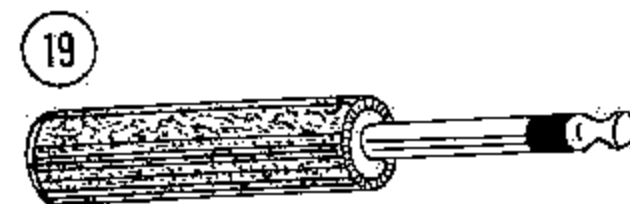
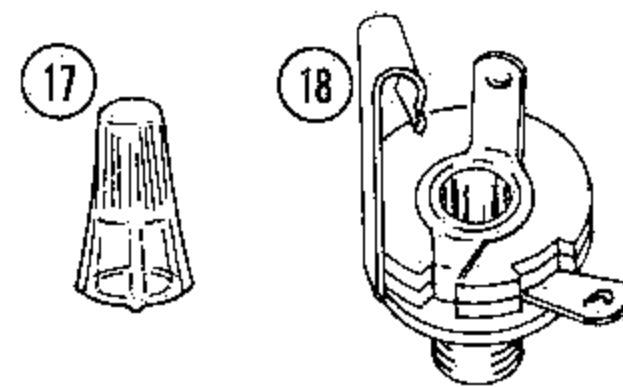

A size "C" flashlight battery should be purchased at this time for use in the completed kit.

STEP-BY-STEP ASSEMBLY

RANGE SWITCH ASSEMBLY

Select the Range switch (#63-500). Study Detail 1A for proper orientation and switch lug designations. Orient the switch by locating the blank space on the front deck between lugs 7 and 8. The lug numbering proceeds clockwise when the switch is viewed from the rear. Two of the three decks, or wafers, are 12-lug wafers and the third is an 11-lug wafer. The lugs will be designated as follows: Front deck, which is the deck nearest the switch shaft, is numbered 1 through 11 at each position. The second deck positions are numbered from 1 through 12, as are the rear deck positions. The rear deck is farthest from the switch shaft. Notice that on the front deck, contacts appear on both sides of the deck, whereas on the remaining decks the contacts are all on one side.

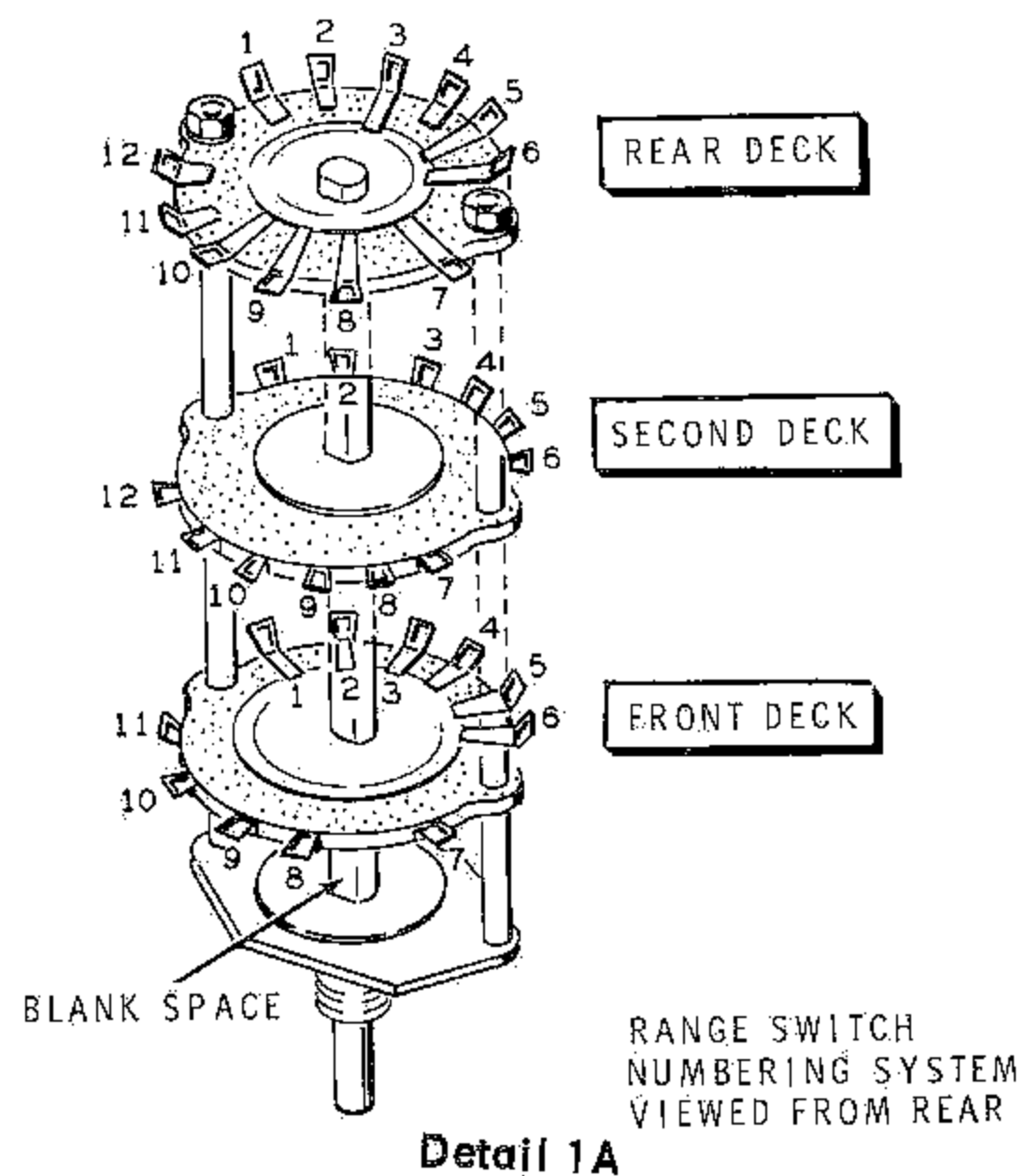

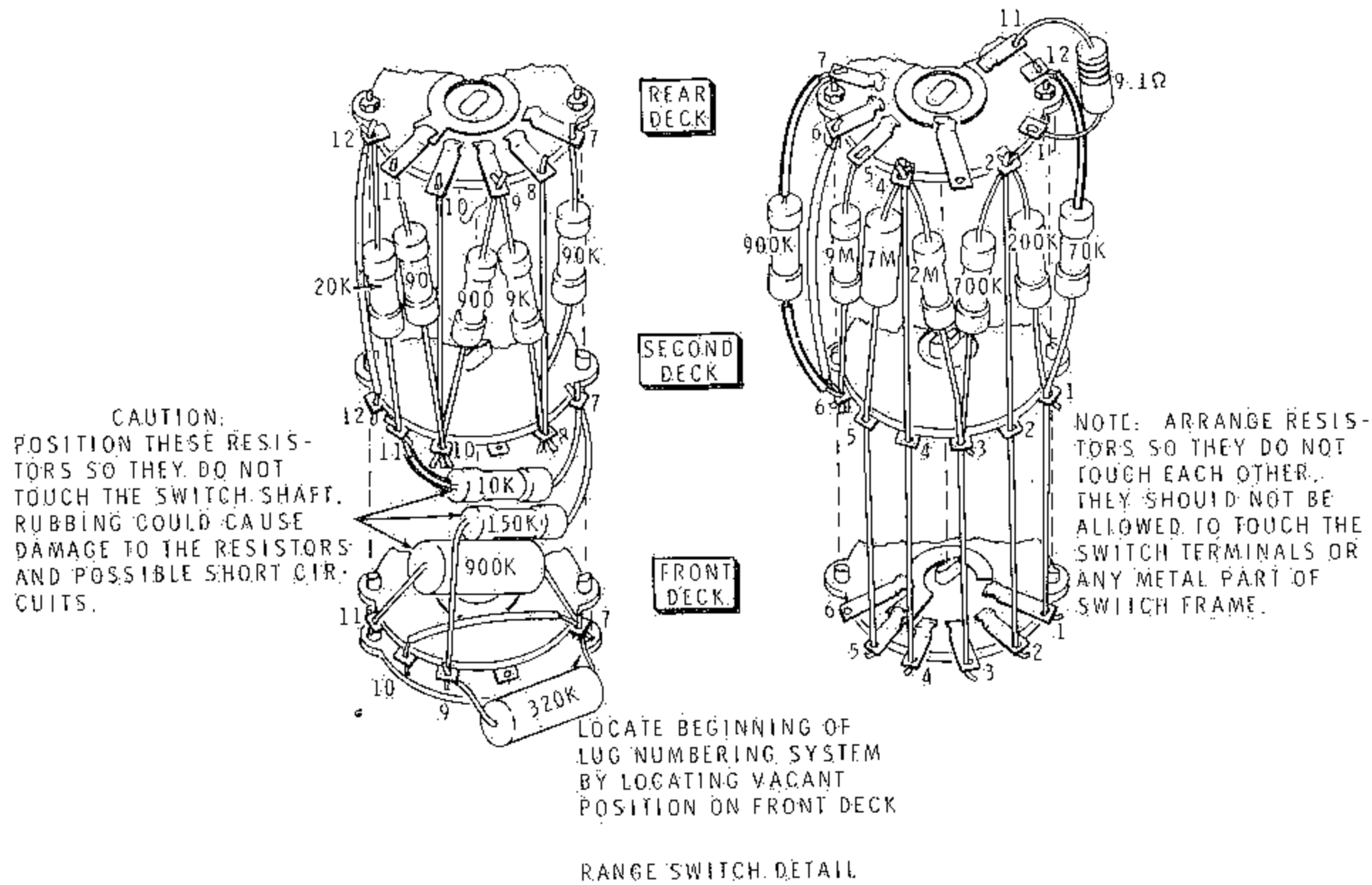

Detail 1B

Refer to Detail 1B for the following steps.

- () R7. Connect a 320 KΩ precision resistor between front deck lug 7 (NS) and the front deck lug 9 (NS), positioning the resistor body between the front deck and the detent plate as shown in Detail 1B. The detent plate is the metal plate at the front of the switch to which no lugs are attached.
- () R6. Connect a 900 KΩ precision 1 watt resistor (the larger of the two 900 KΩ resistors) between front deck lug 7 (NS) and front deck lug 11 (NS). Place the resistor between the front deck and the second deck so that the resistor does not touch the switch shaft. See Detail 1B.

- () R8. Connect a 150 KΩ precision resistor between second deck lug 7 (NS) and the front deck lug 9 (S-2). Place the resistor between the front deck and the second deck as shown in Detail 1B. The resistor should not touch the switch shaft.
- () R23. Connect a 10 KΩ precision resistor between second deck lug 7 (NS) and second deck lug 11 (NS). Use insulating sleeving on the lead to lug 11. Place the resistor between the front deck and the second deck as shown in Detail 1B. The resistor should not touch the switch shaft.
- () Cut a 2" hookup wire and strip 1/4" of insulation from each end. Connect this wire from front deck lug 7 (S-3) to front deck lug 10 (S-1).

() R22. tweed lug

() Conn deck S-1

() R21. from deck Use 12. tweed

() R20. from 2 N

() Conn 2 N from

() R19. from deck body rear

() R18. from lug

() Conn lug to fr

() R17. sist sect NS bet

() R25. sist deck

() Conn deck

- () R22. Connect a 20 K Ω precision resistor between second deck lug 11 (S-2) and rear deck lug 12 (NS).
- () Connect a 1-3/4" hookup wire between rear deck lug 12 (NS) and second deck lug 12 (S-1).
- () R21. Connect a 70 K Ω precision resistor from rear deck lug 12 (S-3) through second deck lug 1 (NS) to front deck lug 1 (S-1). Use sleeving on the lead to rear deck lug 12. The body of the resistor should be between the rear deck and the second deck.
- () R20. Connect a 200 K Ω precision resistor from second deck lug 1 (S-3) to rear deck lug 2 (NS).
- () Connect a 3" bare wire from rear deck lug 2 (NS) through second deck lug 2 (S-2) to front deck lug 2 (S-1).
- () R19. Connect a 700 K Ω precision resistor from rear deck lug 2 (S-3) through second deck lug 3 (NS) to front deck lug 3 (S-1). The body of the resistor should be between the rear deck and the second deck.
- () R18. Connect a 2 megohm precision resistor from second deck lug 3 (S-3) to rear deck lug 4 (NS).
- () Connect a 3" bare wire from rear deck lug 4 (NS) through second deck lug 4 (S-2) to front deck lug 4 (S-1).
- () R17. Connect a 7 megohm precision resistor from rear deck lug 4 (S-3) through second deck lug 5 (S-2) to front deck lug 5 (NS). The body of the resistor should be between the rear deck and the second deck.
- () R25. Connect a 9 megohm precision resistor from rear deck lug 5 (S-1) to second deck lug 6 (NS).
- () Connect a 1-3/4" hookup wire from rear deck lug 6 (S-1) to second deck lug 6 (NS).
- () R26. Connect a 900 K Ω precision resistor from rear deck lug 7 (NS) to second deck lug 6 (S-3). Use sleeving on both leads.
- () R27. Connect a 90 K Ω precision resistor from rear deck lug 7 (S-2) to second deck lug 8 (NS).
- () Connect a 1-3/4" bare wire from rear deck lug 8 (S-1) to second deck lug 8 (NS).
- () R28. Connect a 9 K Ω precision resistor from rear deck lug 9 (NS) to second deck lug 8 (S-3).
- () R29. Connect a 900 Ω precision resistor from rear deck lug 9 (S-2) to second deck lug 10 (NS).
- () Connect a 1-3/4" bare wire from rear deck lug 10 (S-1) to second deck lug 10 (NS).
- () R30. Connect a 90 Ω precision resistor from rear deck lug 11 (NS) to second deck lug 10 (S-3).
- () R31. Connect a 9.1 Ω precision resistor (white-brown-gold-gold) from rear deck lug 11 (S-2) to rear deck lug 1 (NS). Refer to Detail 1B for the position of the resistor body.

This completes the resistor wiring on the Range switch. Before temporarily setting it aside, recheck the entire procedure. Check all resistor leads and bare wires for possible shorting. Visually inspect all solder connections from every angle to make sure a good solder connection has been made. Make sure excess solder has not flowed over to short adjacent connections. Shake out all loose pieces of solder and wire trimmings. At this time no connections have been made at front deck lug 6 and lug 8, second deck lug 9, and rear deck lug 3. The connections made at front deck lug 5 and lug 11, second deck lug 7, and rear deck lug 1 have not yet been soldered.

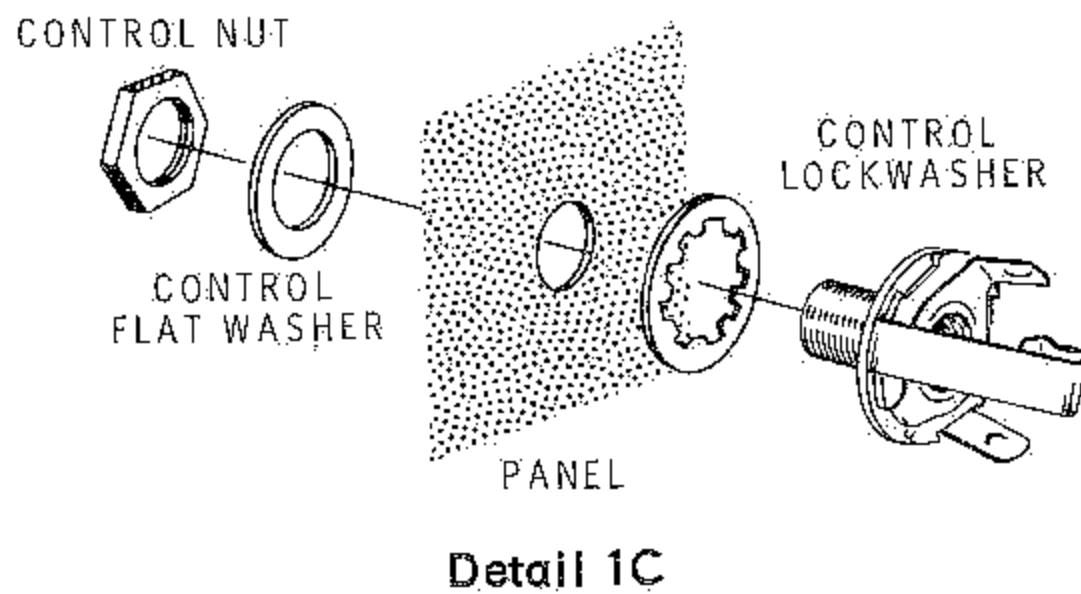

Detail 1C

FRONT PANEL MOUNTING

Refer to Pictorial 1 (fold-out from Page 11) for the following steps.

- () Mount the phone jack on the back of the front panel at position P. Orient the lugs as shown in Pictorial 1. Use a control lockwasher, a control flat washer, and a control nut, as shown in Detail 1C.
- () R1, R2. Similarly, mount 15 K Ω controls at positions O and Z. Use control lockwashers, control flat washers, and control nuts. Orient the lugs of the controls as shown in Pictorial 1.
- () Mount the Function switch (#63-501) as shown in Pictorial 1.
- () Similarly, mount the prepared Range switch using a control lockwasher, control flat washer, and a control nut. Orient the switch as shown in Pictorial 1. (For clarity, the resistors are not shown.)

KNOB INSTALLATION

The knobs supplied with this kit use knob bushings that provide permanent positive gripping without the use of setscrews.

In the following steps you will install a knob on each of the two switch shafts. Perform these steps carefully since it is very difficult to remove a knob bushing from a knob once it is fully inserted.

NOTE: Each knob will be made to align with particular switch markings. Whenever you remove a knob, be sure to replace it on the same switch shaft.

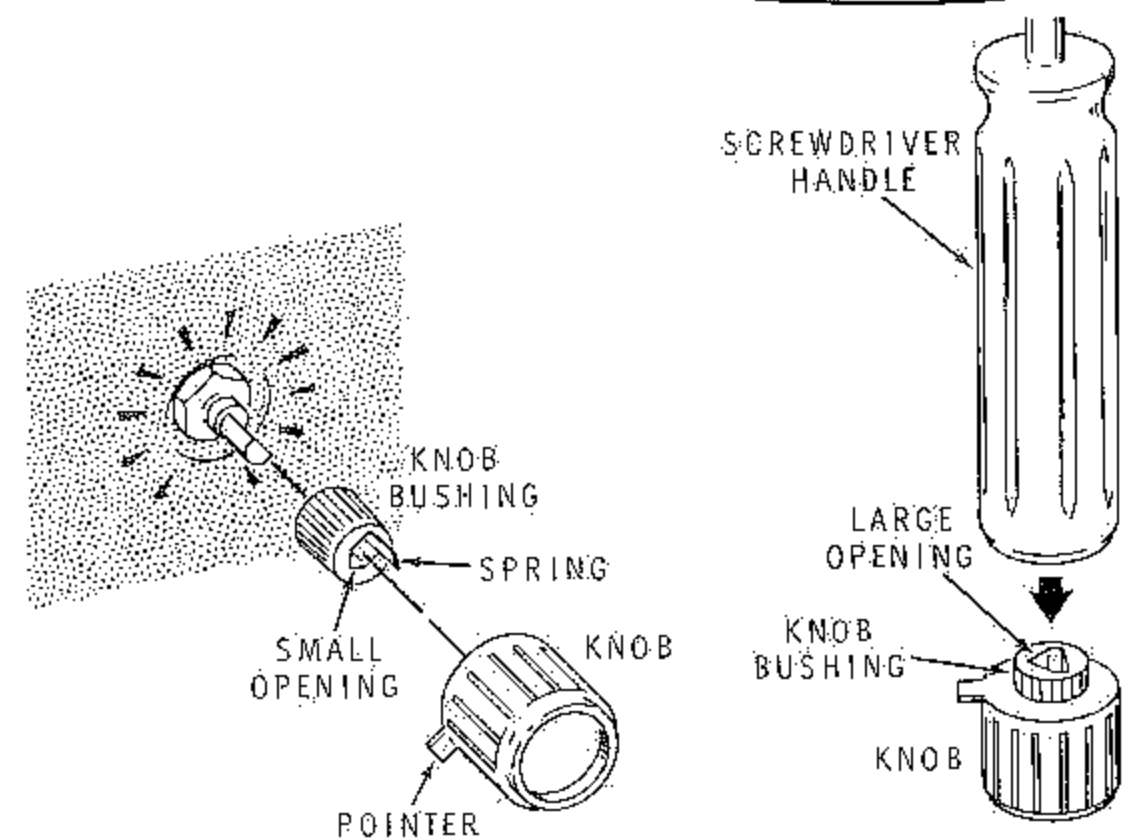

Detail 1D

- () Refer to Detail 1D and push a knob bushing part way onto each of the two switch shafts. Then turn both switch shafts to their full counterclockwise position.
- () Line up the pointer of a knob with the full counterclockwise marking on the panel. Then press the knob slightly onto the knob bushing.
- () Turn the knob clockwise to each of the switch stop positions. Check to see that the pointer lines up with each panel marking.

NOTE: Perform the next three steps only if the pointer does not line up at each switch marking.

1. () Turn the knob pointer to the mid-position marking on the panel.
2. () Remove the knob from the bushing and turn it slightly to line up the pointer with the midposition marking.
3. () Press the knob slightly onto the knob bushing. Then turn the knob to each switch position and recheck the pointer alignment. If more than a slight error is noticed at either end position, repeat these three steps.

- () Carefully remove the knob bushing and knob together.
- () Place the knob on a table or other hard surface, then press the knob bushing firmly into the knob. Use a towel or soft cloth on the work surface to avoid scratching the knob.
- () Press the knob and bushing firmly onto the switch shaft.
- () Repeat the above Knob Installation steps to install a knob on the remaining switch shaft.

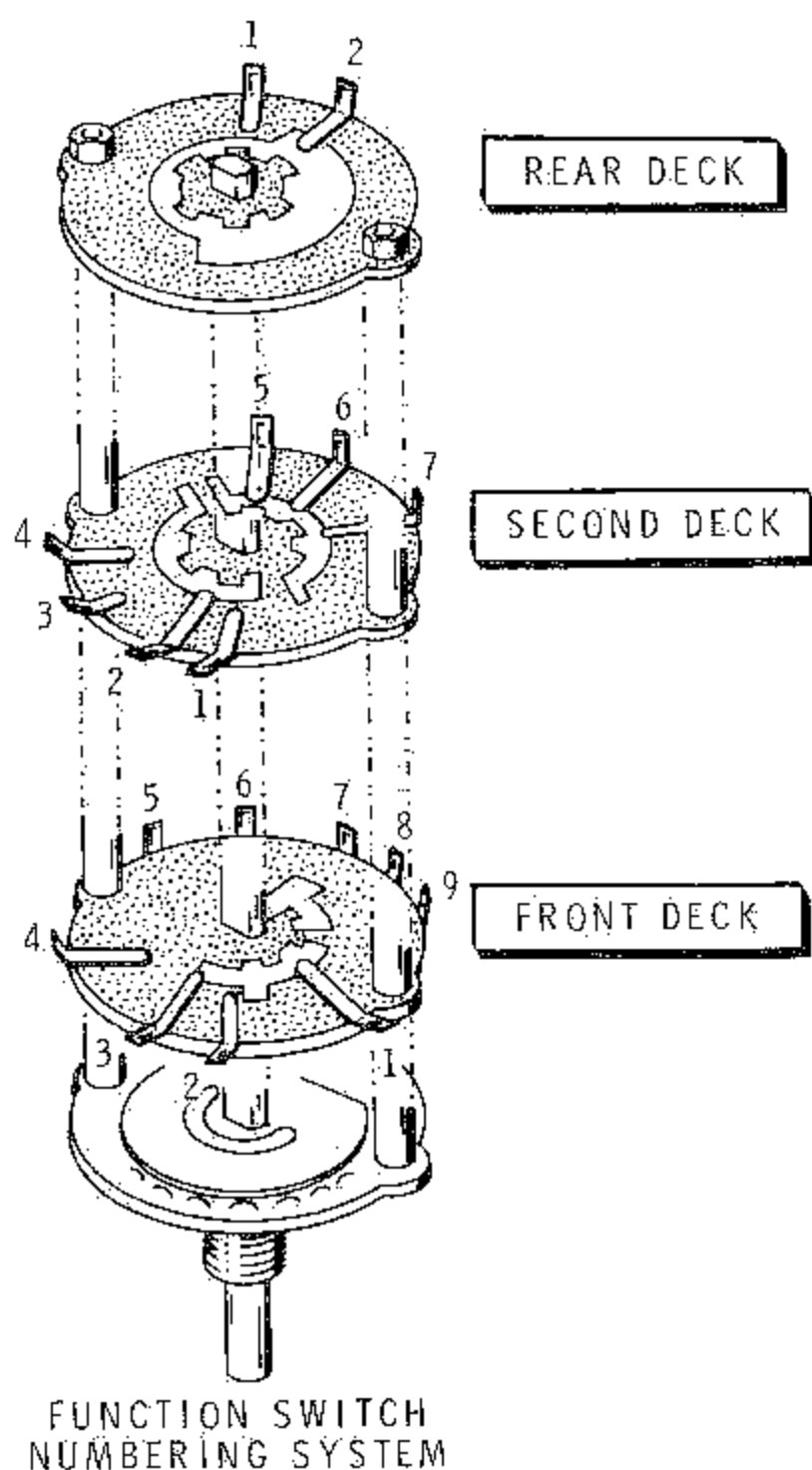

Detail 2A

FRONT PANEL WIRING

Study the Function switch numbering system as shown in Detail 2A. The front deck of the switch is the wafer closest to the front panel.

Refer to Pictorial 2 (fold-out from this page) for the following steps.

- () C2. Connect a .047 μ fd 1600 volt capacitor from the Range switch front deck lug 11 (S-2) to Function switch front deck lug 4 (S-1), using sleeving on both leads. The banded end goes to the Function switch. The capacitor body should be placed flush with the front panel between the Range switch and the Function switch as shown in Pictorial 2. Avoid using excessive solder, since both leads carry high voltage.
- () Connect a 3-1/2" hookup wire from lug 3 of control O (S-1) to Function switch second deck lug 6 (S-1).
- () Connect a 5-1/2" hookup wire from lug 2 of control O (S-1) to lug 1 of control Z (NS). Place the wire close to the front panel.
- () Connect a 2-1/4" hookup wire from lug 3 of control Z (S-1) to Function switch second deck lug 7 (NS).
- () Connect a 1-3/4" hookup wire from Function switch front deck lug 5 (NS) to lug 2 of phone jack P (S-1). Use sleeving over the entire length of this wire. Avoid using excessive solder, since this wire carries high voltage.
- () Connect a 1-3/4" hookup wire from Function switch front deck lug 6 (S-1) to Range switch front deck lug 5 (S-2).
- () Connect a 4" hookup wire from Function switch front deck lug 8 (S-1) to Range switch second deck lug 9 (S-1).
- () Connect a 4-1/2" hookup wire from Function switch front deck lug 1 (S-1) to Range switch front deck lug 6 (S-1).
- () Connect a 6" hookup wire from Function switch front deck lug 2 (S-1) to Range switch rear deck lug 3 (S-1).
- () Connect a 2-1/2" hookup wire from Function switch front deck lug 3 (S-1) to Function switch front deck lug 5 (S-2). Use sleeving over the entire length of this wire. Avoid using excessive solder since this wire carries high voltage.
- () Connect a 4-3/4" hookup wire from Function switch second deck lug 3 (NS) to Range switch front deck lug 8 (S-1).
- () Connect a 2-3/4" hookup wire from Range switch second deck lug 7 (S-3) to lug 1 of phone jack P (NS).
- () Connect a 5-1/2" hookup wire to lug 1 of phone jack P (NS). Leave the other end free for connection later.
- () Connect a 5-1/2" hookup wire to lug 1 of phone jack P (S-3). Leave the other end free for connection later.



CUT THIS PIN OFF
CLOSE TO SOCKET
BODY.

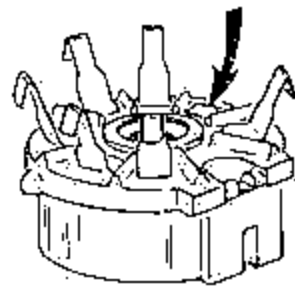

PLACE PINS INTO MOUNTING
HOLES. MAKE SURE HOOKS
ARE SEATED IN HOLES BEFORE
PRESSING DOWN.

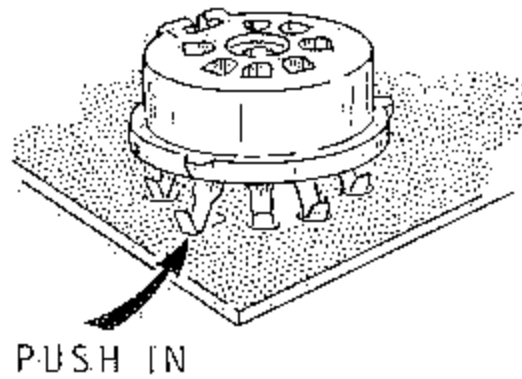

APPLY PRESSURE EVENLY
UNTIL SOCKET IS TIGHT
ON BOARD.

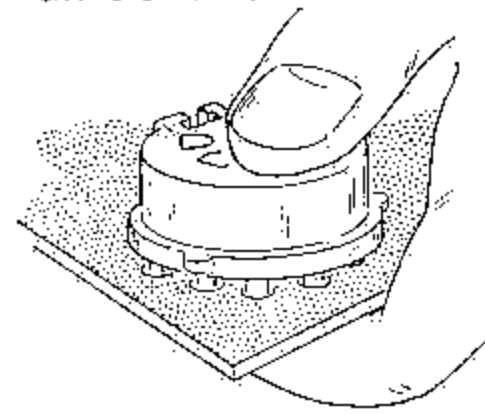

Detail 3A

CIRCUIT BOARD WIRING

- () Using diagonal wire cutters, clip off lug 6 of the 7-pin tube socket. To locate lug 6, count clockwise from the blank space on the bottom of the socket. See Detail 3A.
- () Properly orient the 7-pin socket and install it through the lettered side of the board in the smaller of the two socket locations, as shown in Pictorial 3. Refer to Detail 3A for the mounting procedure. Be sure the lug hooks are seated in the holes before pressing down on the socket.
- () Turn the board over and solder the socket pins to the circuit board foil.
- () Install the 9-pin socket and solder the socket pins to the circuit board foil. Do not clip off any of the pins of the 9-pin socket.

Refer to Pictorial 3 for the following steps.

- () R24. Install a 3.3 megohm (orange-orange-green) resistor in the position designated on the lettered side of the circuit board. Bend the leads at right angles to the resistor body.

Insert the leads in the correct holes and spread the leads slightly so the resistor will not drop out of position when the board is turned over for soldering. All of the remaining circuit board resistors will be mounted before they are soldered.

- () R34. Install a 220 K Ω (red-red-yellow) resistor in position on the circuit board.
- () R33, R35. Install two 150 K Ω (brown-green-yellow) resistors.
- () R16. Install a 27 K Ω (red-violet-orange) resistor.
- () R32. Install a 10 megohm (brown-black-blue) resistor.
- () R9, R10, R11, R12, R13. Install five 22 megohm (red-red-blue) resistors in the five positions shown.
- () R15. Install a 100 Ω (brown-black-brown) resistor.
- () R14. Install a 10 K Ω (brown-black-orange) resistor. Position the 10 K Ω resistor slightly toward the center of the circuit board so that it will clear the AC Balance control terminals, as shown in Pictorial 3.

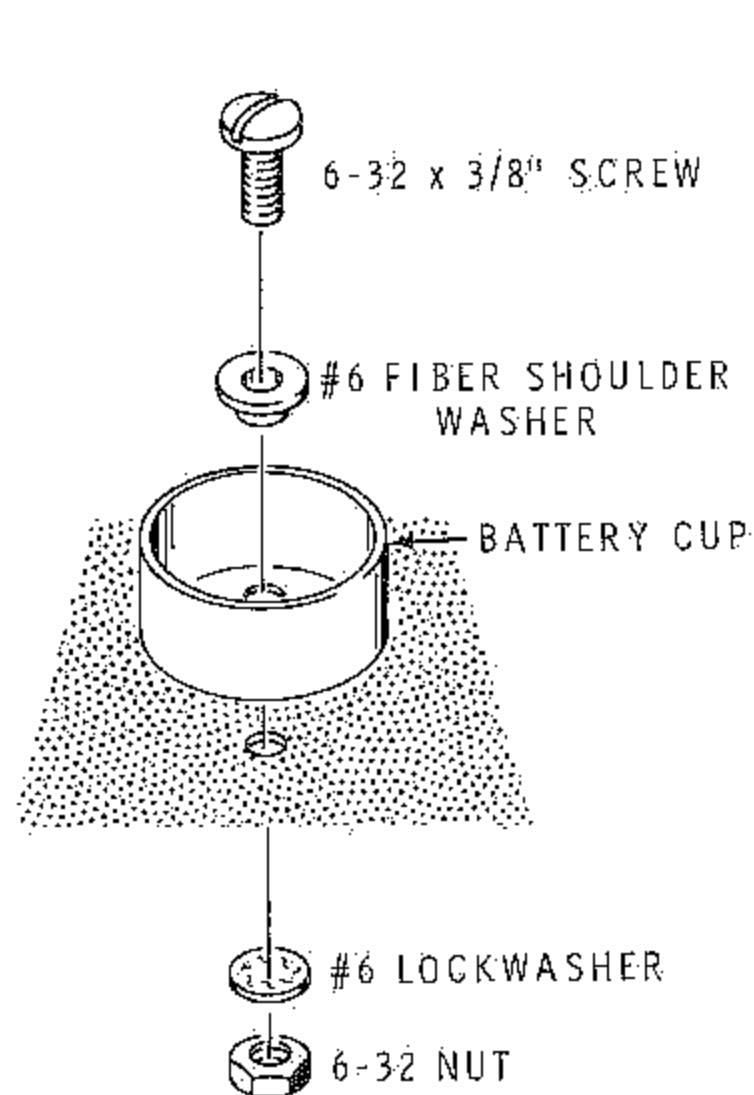

BATTERY CUP MOUNTING ON LETTERED
SIDE OF CIRCUIT BOARD

Detail 3B

Check all the resistors for snug positioning against the board. Now turn the circuit board over, solder each lead and trim off the excess lead close to the board surface. Carefully check each connection after clipping the leads, to make sure a good solder connection has been made.

NOTE: A plastic nut starter has been provided with this kit. Use it to hold and start nuts on screws. See Page 3 of the Kit Builders Guide for more information.

() Mount the battery cup in position on the lettered side of the circuit board. Use a 6-32 x 3/8" screw, #6 fiber shoulder washer, #6 lockwasher, and 6-32 nut, as shown in Detail 3B.

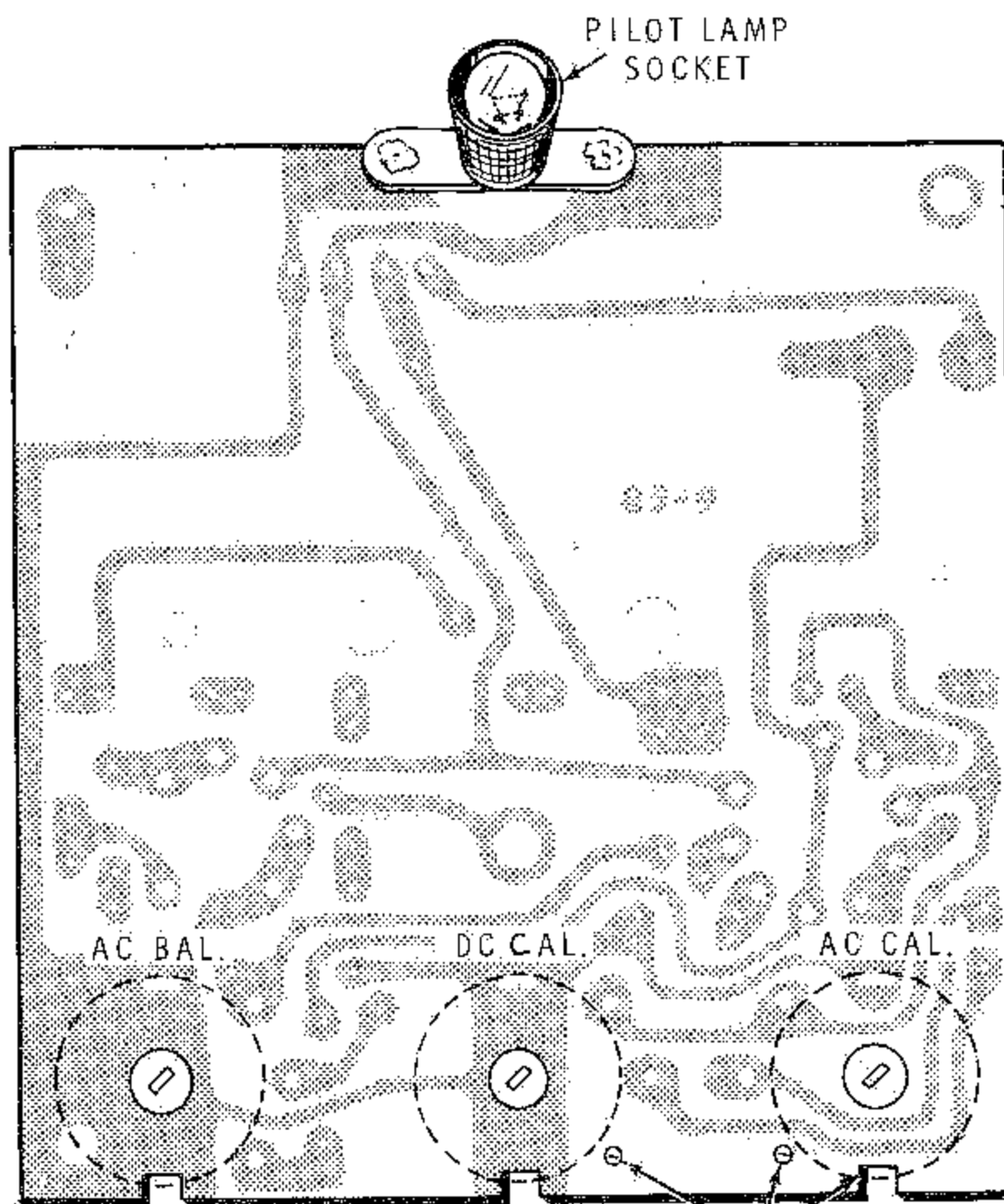

NOTE: THESE LUGS
ARE NOT USED.
DO NOT SOLDER

Detail 3C

() R3, R4, R5. Mount the three 10 K Ω controls (AC CAL, DC CAL, and AC BAL) on the lettered side of the circuit board so that the mounting lugs and terminals protrude through the foil side. Refer to Pictorial 3 and Detail 3C. Hold the controls firmly against the board and solder the mounting lugs and terminals directly to the foil pattern. Notice that the three lugs which do not connect to the foil pattern are not soldered, as mention in the note in Detail 3C.

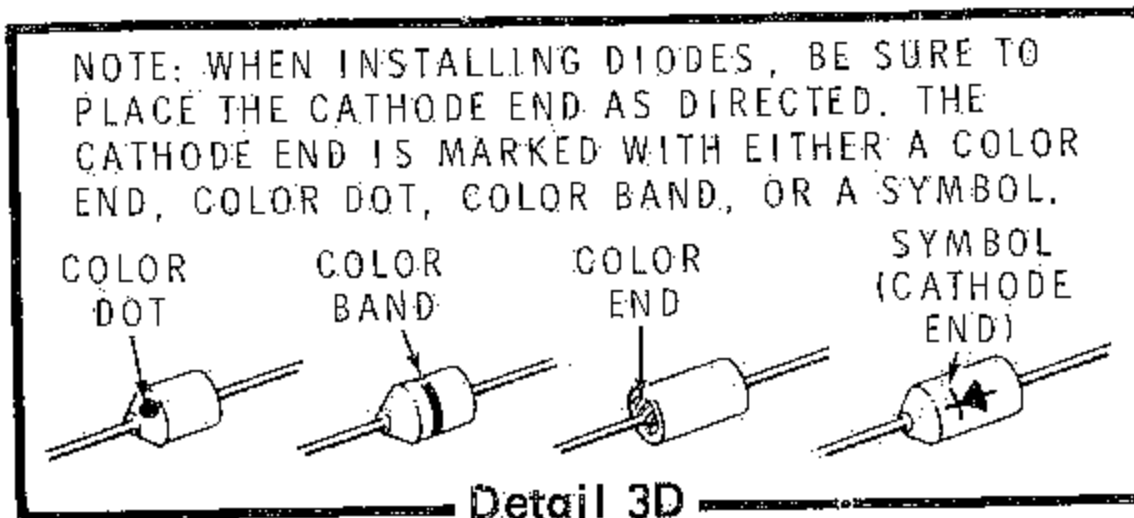

- () Refer to Detail 3D and identify the cathode lead of the silicon diode. Mount the silicon diode on the circuit board. Position the cathode lead end as shown in Pictorial 3. Solder both leads to the foil and clip off the excess lead lengths close to the foil.
- () Mount the power transformer (#54-23-24) as shown in Pictorial 3. Use two 6-32 x 3/8" screws, two #6 lockwashers, and two 6-32 nuts. Do not tighten the upper mounting screw permanently. The black transformer lead must be toward the right side of the circuit board. Notice that the 6-32 screw closest to the tube sockets is inserted from the foil side of the board with the nut attached on the lettered side. This is done to insure adequate clearance for the plastic meter housing after the board is installed in the instrument.
- () The transformer leads are precut to their proper lengths. Insert the two yellow transformer leads in the holes marked Y and the two red transformer leads in the two holes marked R. Solder these four leads to the foil side of the board.

NOTE: The power transformer has a dual primary winding and can be wired to operate from either 120 volts or 240 volts. Determine the AC line voltage in your area and follow the proper set of steps to wire the power transformer. Perform either the 120 Volt Wiring steps or the 240 Volt Wiring steps.

120 Volt Wiring

- () Make sure there is at least 3/8" of bare wire at the end of the black transformer lead. Insert this lead in hole BL in the circuit board. Leave the excess bare wire above the circuit board and solder the lead to the foil (S-1).
- () Form a hook in the bare wire at the end of the black-green transformer lead and place the hook around the bare wire of the black lead above the circuit board (S-1). The black-red and the black-yellow wires will be connected later.

240 Volt Wiring

- () Insert the black transformer lead into hole BL in the circuit board (S-1). Cut off any excess lead length.
- () Cut the black-yellow lead to the same length as the black-green lead and remove 3/8" of insulation from the cut end.
- () Insert the black-green and the black-yellow leads into the solderless connector so that both bare ends enter the wire coil inside the tip. Hold the leads with one hand and twist the connector until you feel resistance. This twists the wires together for a good connection. The black-red lead will be connected later.
- () C5, C6. Mount and solder the two .005 μ f disc ceramic capacitors in their places as shown in Pictorial 3.
- () C3, C4. Mount and solder the two .02 μ f disc ceramic capacitors in their places as shown in Pictorial 3.
- () C1. Mount and solder the 16 μ f 150 V electrolytic capacitor as shown in Pictorial 3. Be careful to align the positive (+) end of the electrolytic capacitor adjacent to the diode.

- () Place the pilot lamp socket in the location shown in Detail 3C on Page 13. The screw threads on the pilot lamp socket protrude from the foil side of the circuit board. Solder the lugs directly into the foil.

CONNECTING CABLE

- () Locate the 12" length of 8-wire, color coded cable. Measure 5" from one end of the cable and carefully remove the cable sheathing by making a circular cut with a small sharp knife and then slipping the cable sheathing off. Be careful not to cut the internal wires or their insulation.

Measuring from the cut end of the sheath, cut the wires to the following lengths:

<u>COLOR</u>	<u>LENGTH</u>
() Green	1/2"
() Yellow	3/4"
() Red	1-1/4"
() Black	1-3/4"
() Brown	2"
() White	3"
() Blue	4"
() Orange	4-1/4"

- () Carefully remove 3/16" of insulation from the end of each wire. Twist the fine wire strands lightly together and insert the color coded wires in their respective openings in the lettered side of the circuit board, as shown in Pictorial 4. The actual color code abbreviations used on the back of the circuit board are as follows: Black (BL), red (R), yellow (Y), green (G), orange (OR), blue (B), white (W), brown (BR). Solder each wire to the foil circuit as it is inserted. Clip off any excess wire on the wire strands and avoid making solder bridges to other parts of the foil circuit. Place the blue wire between the battery clip and the DC BAL control.

- () Solder one end of a 4" hookup wire to point X on the circuit board. See Pictorial 4. The other end of the wire is not connected at this time.

The circuit board is now completely assembled and is ready for installation.

WIRING CIRCUIT BOARD TO THE PANEL

- () Measure 4" back from the free end of the 8-wire cable and remove the sheathing, being careful not to cut the internal wires or their insulation. Do not cut the green and blue wires, but cut 1" from the ends of the remaining six wires. Remove 1/4" insulation from the ends of all eight wires.

To make the wiring as easy as possible, the cable wires will be connected to the front panel assembly before the circuit board is mounted.

Refer to Pictorial 4 (fold-out from Page 12) for the following steps.

- () Connect the orange wire to Function switch front deck lug 7 (S-1).
- () Connect the black wire to Function switch front deck lug 9 (S-1).
- () Connect the white wire to lug 2 of control Z (S-1).
- () Connect the red wire to lug 1 of control Z (S-2).
- () Connect the brown wire to Function switch second deck lug 7 (S-2).
- () Connect the yellow wire to Function switch second deck lug 1 (S-1).
- () Connect the green wire to Function switch second deck lug 4 (S-1).
- () Connect the blue wire to Range switch rear deck lug 1 (S-2).

This completes the circuit board wiring to the front panel.

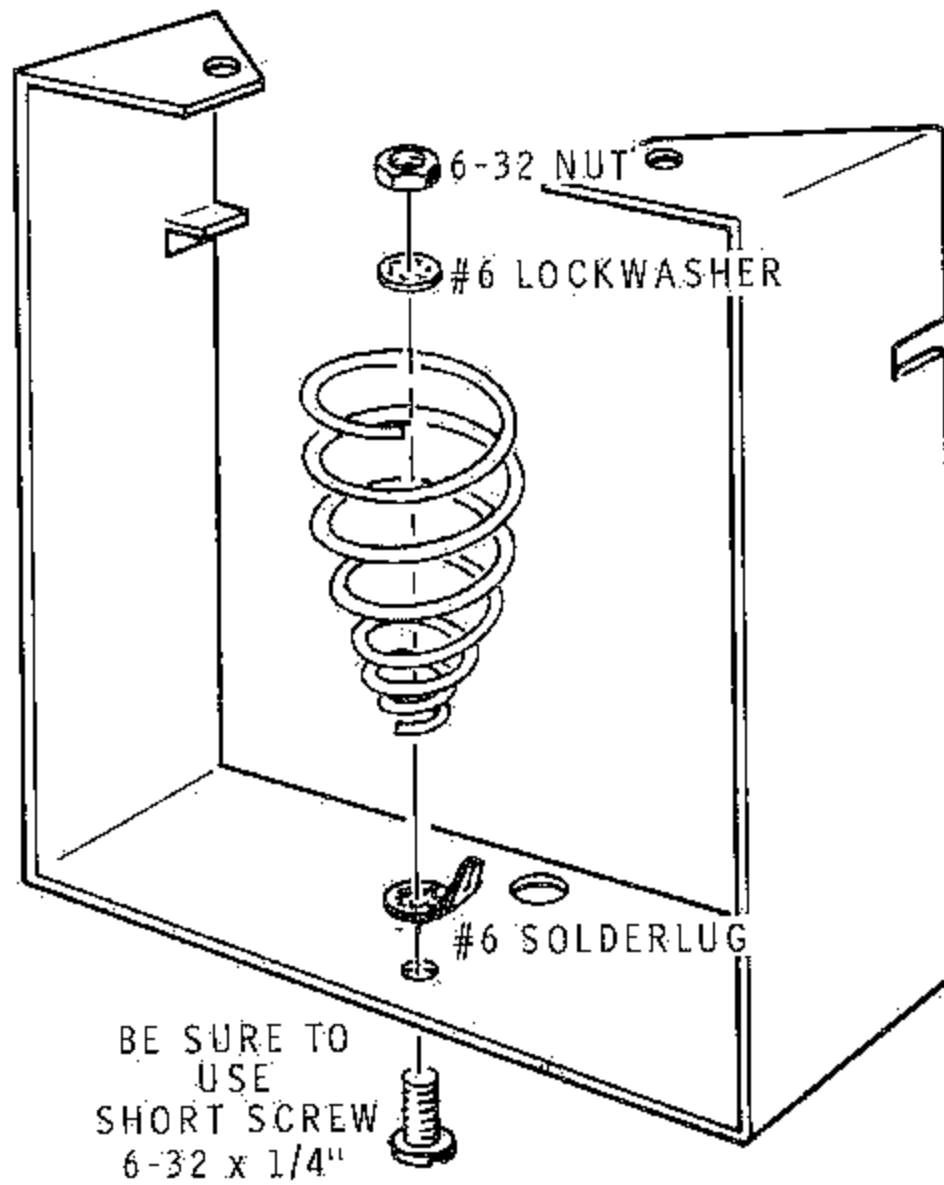

METHOD OF ASSEMBLING BATTERY SPRING
TO BRACKET

Detail 5A

MOUNTING THE BATTERY SPRING

- () Install the large battery holder spring on the bracket as shown in Detail 5A. Use the 6-32 x 1/4" screw, #6 lockwasher, #6 solder lug, and 6-32 nut. The lockwasher and nut should be on the inner side of the bracket, inside the spring. Otherwise the body of this screw will protrude through the back of the completed VTVM. Position the solder lug so that it does not obstruct the other hole in the bracket. Long-nose pliers should be used to hold the nut while the screw is tightened.

METER, BRACKET, AND CIRCUIT BOARD INSTALLATION

- () Before installing the meter, it is necessary to remove the solder lugs and the wire between the meter terminals. On each terminal hold the lower nut with long-nose pliers while loosening the upper nut with a 3/8" socket wrench or another pair of pliers. **DO NOT PERMIT THE THREADED TERMINAL STUD TO TURN.** Next, tighten the remaining nuts snugly against the meter stud speednut on the back of the meter, using finger pressure only. Again, be sure that the stud itself does not turn.

NOTE: While mounting the meter to the panel, be sure to use a soft cloth on the workbench surface to avoid scratching the plastic meter housing.

- () Insert the four meter mounting screws in the holes in the front panel. Looking at the panel from the rear, fasten the upper left meter mounting screw to the panel using a brass 6-32 nut and brass #6 lockwasher, packed in the meter box. Only this nut should be installed at this time.

- () Mount the Z bracket on the upper right meter mounting screw as shown in Detail 5B, using the brass meter mounting hardware. Note the orientation of the off-center holes in the Z bracket.

- () Install the large bracket on the two lower meter mounting screws as shown in Pictorial 5, using the brass hardware. NOTE: The bracket must straddle the cable. As the mounting nuts are being tightened, lightly pinch together the two legs of the bracket to insure adequate clearance between the legs and the panel edge.

- () Screw the pilot lamp into the pilot lamp socket at the top of the circuit board. Slip the 1-1/4" length of 3/8" diameter fiberglass sleeving over the pilot lamp and socket.

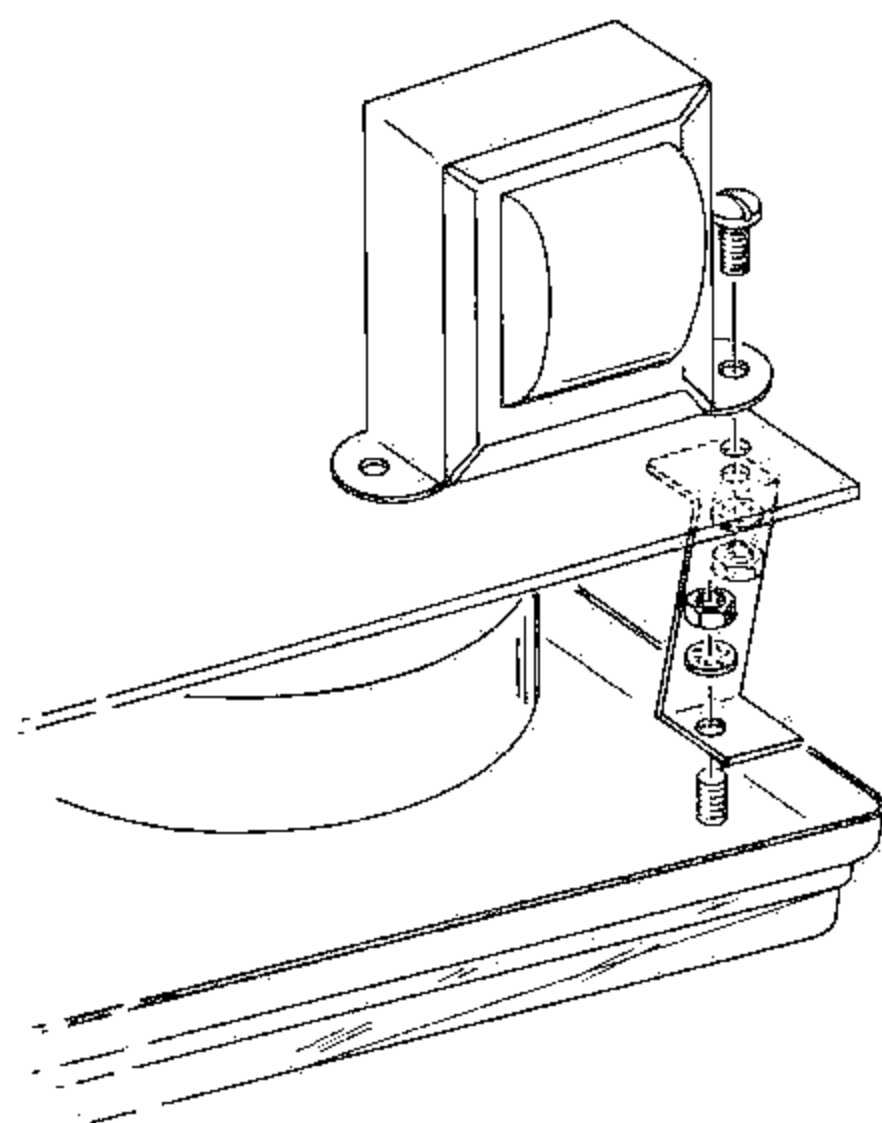

Detail 5B

- () Remove the 6-32 hardware at the top transformer mounting lug. Refer to Detail 5B. Temporarily set aside this hardware.
- () Place a #10 fiber washer over each of the two meter terminal studs. Slip the circuit board between the bracket legs so that the meter stud terminals pass through the mounting holes in the circuit board. The bottom edge of the circuit board will now rest on the two small flanges at the notches in the bracket legs. Replace the two solder lugs and the meter stud nuts over the meter stud terminals, marked M1 and M2 in Pictorial 5. Orient the lugs as shown in Pictorial 5 and very lightly tighten the nuts. Bend the lugs slightly away from the circuit board to facilitate soldering later.
- () Align the circuit board so that its edges are parallel to the panel edges and completely clear each side. Now bend the Z bracket toward the right side of the panel and slightly crimp the top of the Z bracket so that its top mounting hole lines up with the top mounting hole of the transformer on the

circuit board, and the top of the Z bracket lies flush against the circuit board. Replace the 6-32 hardware in the top transformer mounting lug, securing the transformer and circuit board to the Z bracket, as shown in Detail 5B.

- () Now tighten the nuts over the meter stud terminals firmly but not excessively. Also tighten the 6-32 transformer mounting hardware to the Z bracket.

FINAL WIRING

Refer to Pictorial 5 for the following steps.

- () Connect the hookup wire from location X on the circuit board to Function switch second deck lug 3 (S-2).
- () Connect either hookup wire from lug 1 of phone jack P to circuit board location Z (S-1).
- () Connect the remaining hookup wire from lug 1 of phone jack P to the solder lug under the battery spring on the large bracket (NS).
- () Connect a 6-1/4" hookup wire from M1 (S-1) to Function switch second deck lug 5 (S-1).
- () Connect a 6" hookup wire from M2 (S-1) to Function switch second deck lug 2 (S-1).

NOTE: Observe that the two edges of the flat line cord are different. One edge is smooth but the other edge is ribbed for identification.

- () Separate the three wires of the line cord to a point approximately 5" from the end. Cut 2" from the ends of both the green wire and the smooth wire.
- () Remove 1/4" of insulation from the end of each line cord wire. Melt a small amount of solder on the twisted bare strands of each line cord wire to keep the fine wires together.

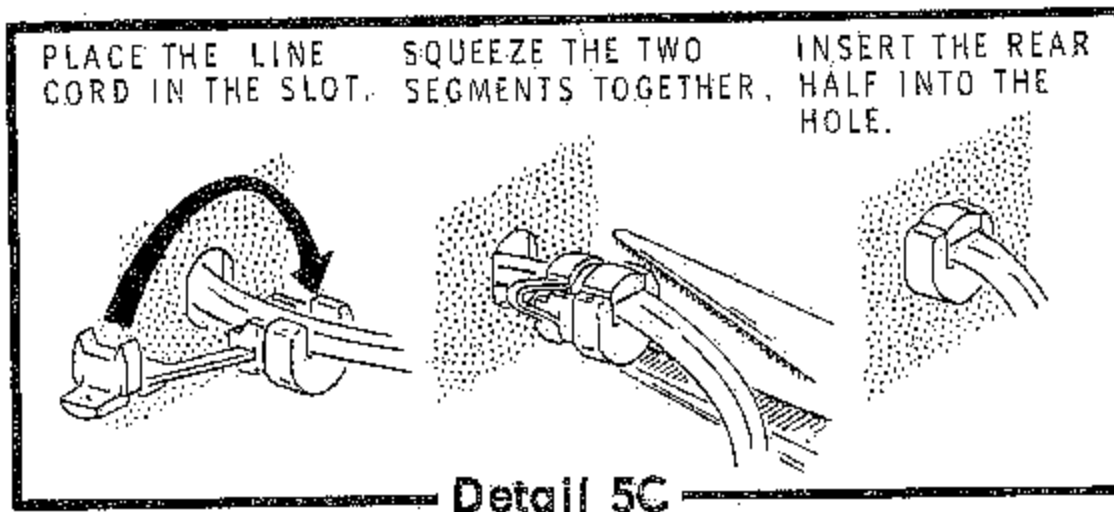

- () Position the proper strain relief on the line cord about 7" back from the end of the longest wire. Detail 5C shows the strain relief (#75-71) for the flat line cord supplied with the kit. If a round line cord is used, install the other strain relief.
- () Install the strain relief and line cord through the large hole in the bracket as shown in Pictorial 5.
- () Connect the smooth line cord wire to Function switch rear deck lug 2 (S-1).
- () Solder the ribbed line cord wire to the position marked "line" in the upper right-hand corner of the circuit board, near the transformer (S-1).
- () Connect the green line cord wire to the solder lug under the battery spring on the large bracket (S-2).

NOTE: Perform only one of the following two steps.

- () If your VTVM is being wired for 120 Volt operation, twist the black-red and black-yellow transformer leads together and connect both to Function switch rear deck lug 1 (S-2).
- () If your VTVM is being wired for 240 Volt operation, connect the black-red transformer lead to Function switch rear deck lug 1 (S-1).

- () Install the 6AL5 tube and 12AU7 tube in their respective sockets as shown in Pictorial 6. Be careful not to damage the tube prongs when inserting them into their sockets.
- () Fasten the handle on the cabinet, using two #10 x 1/2" sheet metal screws.
- () Push the rubber feet into the four holes in the bottom of the cabinet.
- () Install the battery. Start the top (+) end of the battery into the battery cup and then pull the spring out and over the bottom (-) end of the battery. Now push the spring and the battery in so the spring, battery, and battery cup are all in line, as shown in Pictorial 6. Make sure the spring contacts the negative (-), metal, end of the battery.

PRELIMINARY TEST

Carefully inspect the instrument and check the "dress" (or arrangement) of all wiring. Be sure the wiring and components are not positioned in such a way that short circuits may occur. Check all solder connections. Gently shake out all loose wire clippings, insulation, and other debris that may have accumulated during the assembly of the instrument.

Make sure that the mechanical zero position of the meter pointer is correct. If not, adjust as follows:

- () Place the instrument in the normal operating position. Turn the plastic screw on the meter face with a screwdriver while gently tapping the meter face with one finger until the pointer coincides with the zero line on the left side of the scale.

Plug the VTVM line cord into the proper voltage AC source. Turn the Function knob to the DC+ or DC- position and the Range switch to the 1.5 V position. The tubes and pilot lamp should light within 15 to 20 seconds of warmup time.

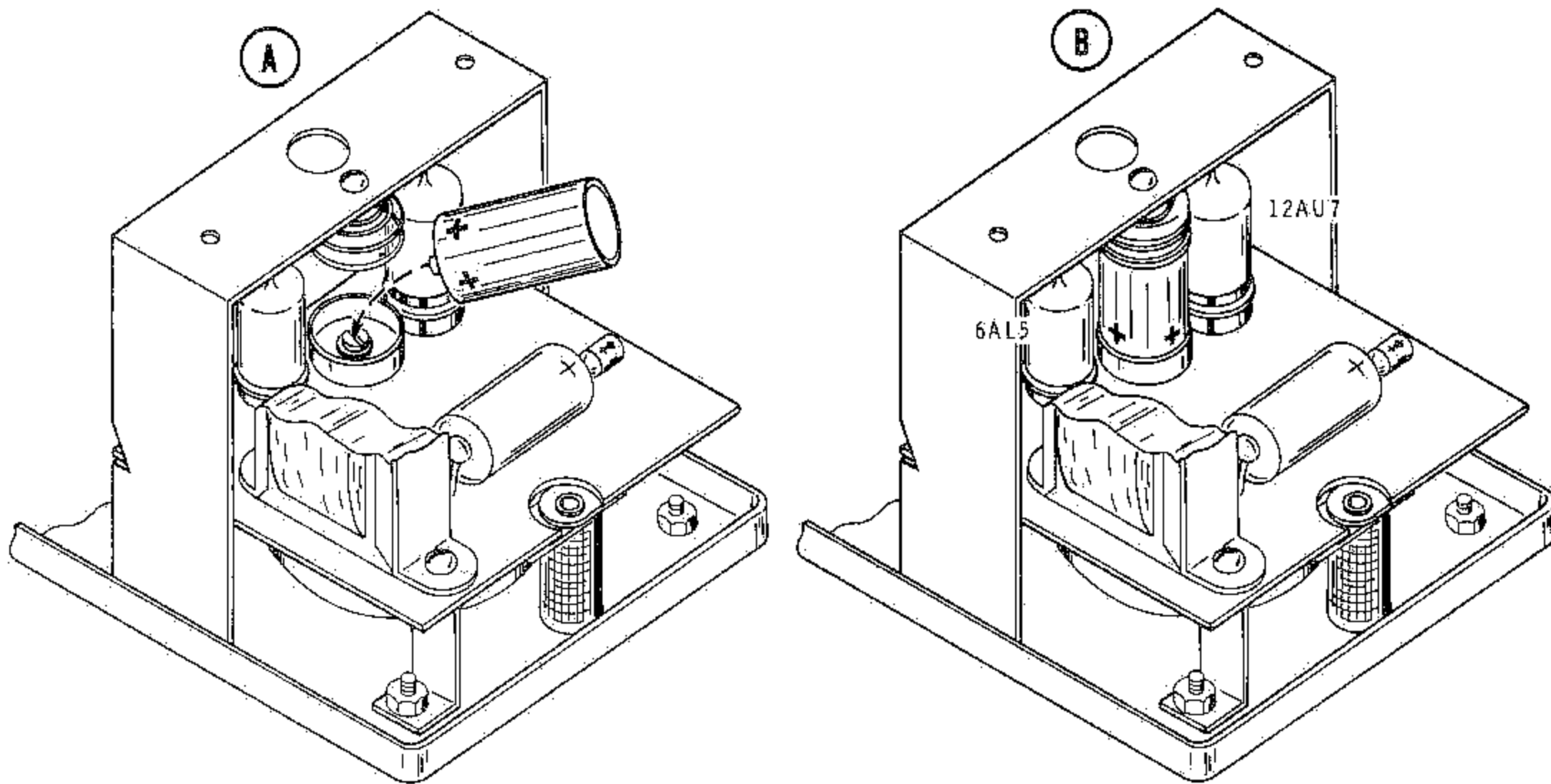

PLACE POSITIVE END OF BATTERY IN THE CUP. WORK THE SPRING OVER THE OTHER END AND POSITION AS IN PART B.

LOCATION OF TUBES AND BATTERY.

PICTORIAL 6

When the VTVM is first turned on, the meter pointer will normally deflect to full scale and then return to, or near, the zero position. This is caused by the 12AU7 tube stabilizing during warmup. There should be some degree of ZERO ADJ control action which will permit the meter pointer to deflect over a limited range of the dial. During the preliminary test warmup,

check the instrument assembly very carefully for any indication of overheating. Assuming that the instrument will respond in the manner indicated, it will be safe to leave it turned on to thoroughly warm up while the balance of the kit project is completed. This will consist of test probe preparation and cabinet assembly.

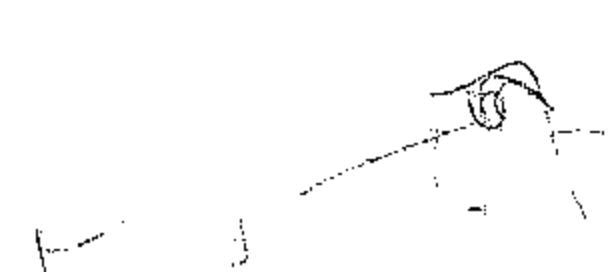

PREPARATION OF TEST PROBE AND LEADS

NOTE: Read all the remaining assembly steps and familiarize yourself with the completed assembly and parts before proceeding.

Refer to Pictorial 7 (fold-out from this page) for an exploded view of the probe assembly.

- () Locate the probe insert insulator. If necessary, remove any "flash" or sharp edge on the insert insulator with a file or penknife.
- () R36. Locate the two small rivets and the 1 megohm (brown-black-green) resistor shown in Detail 7A. Insert the rivets into the holes in the insulator so that the head of each rivet rests on the small shoulder around the hole in the insulator. Now turn the insulator over and lay it flat on the workbench.

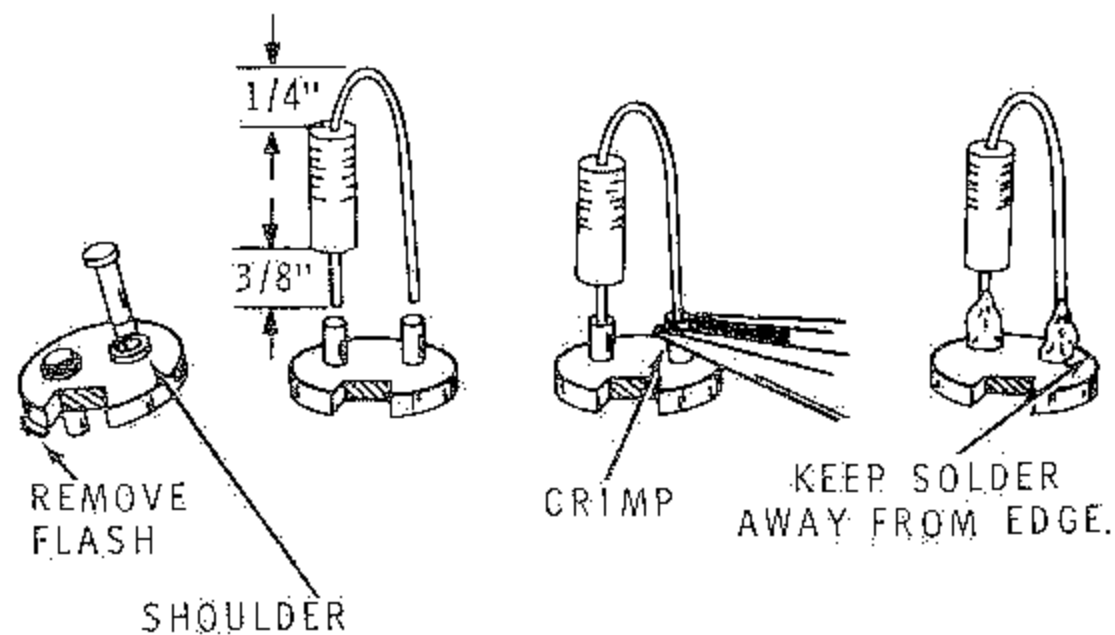

Detail 7A

- () Cut one resistor lead to $3/8$ ". Bend the other lead over and cut flush with the first lead as shown in Detail 7A. Squeeze the leads together so that they line up with the rivet holes.
- () Insert the resistor leads into the rivets and lightly crimp the rivets with long-nose pliers or diagonal cutters to hold the resistor.

NOTE: Before proceeding further, check the orientation of the resistor on the insulator. With the notch in the insulator facing you, the resistor should be on the left-hand side.

- () Solder the resistor leads to the rivets. Make sure the resistor is square with the insert insulator and that the solder flows down the rivet to hold the rivet tight against the shoulder. NOTE: Keep solder away from the edge of the insert insulator to provide clearance for the internal shoulder of the probe center section.

- () Strip $1/2$ " of the outer insulation from one end of the shielded test cable. Clip off the shield wires up to the outer insulation. It is absolutely essential that the shield wires on this end of the shielded test cable be completely insulated from the rest of the probe tip. DO NOT wrap the joint with tape of any kind as this could cause a high resistance leakage path across the shielded portion and the resistor lead.

NOTE: In the following steps, take special care to avoid melting or cutting the inner plastic insulation of the shielded test cable. When soldering, hold the wire with long-nose pliers near the insulation to conduct the heat away from the plastic insulation.

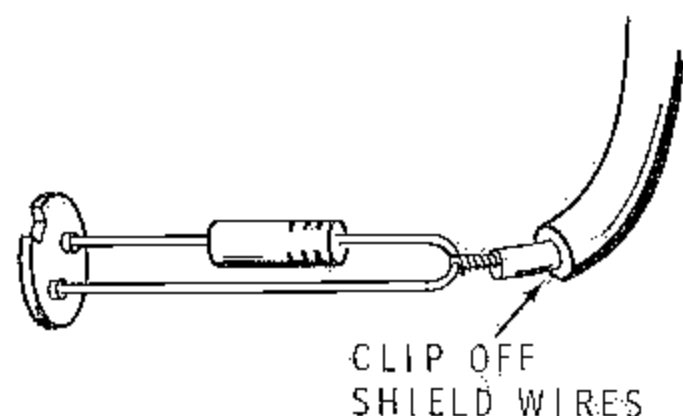

Detail 7B

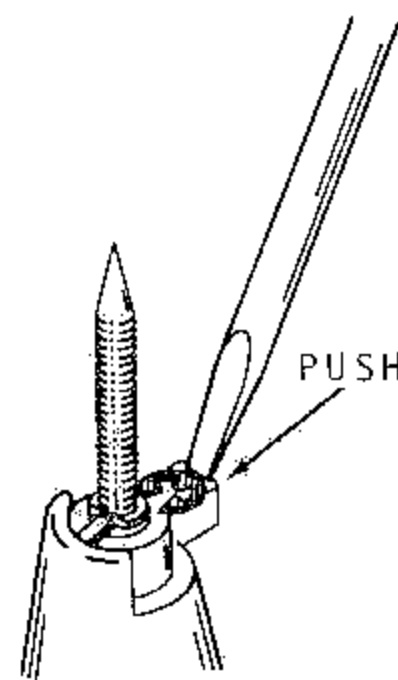

Detail 7D

- () Remove 1/4" of the inner insulation from the shielded cable and solder to the resistor lead as shown in Detail 7B. Use only enough heat to cause a good solder connection, being careful not to melt the inner insulation of the shielded cable.
- () Refer to Detail 7C for the assembly of the front section of the probe, being careful to observe the orientation shown. Assemble the probe spike, the spring, the front section of the probe body, and the switch lever as shown. Push the switch lever flush against the front section of the probe body so that the small retaining ring notch in the spike is

exposed. While holding the spike in firmly against the spring pressure with one hand, use a screwdriver or penknife to insert the retaining E washer into the notch in the spike as shown in Detail 7D. When this E washer is securely in place, the spike will be locked to the front section of the probe body.

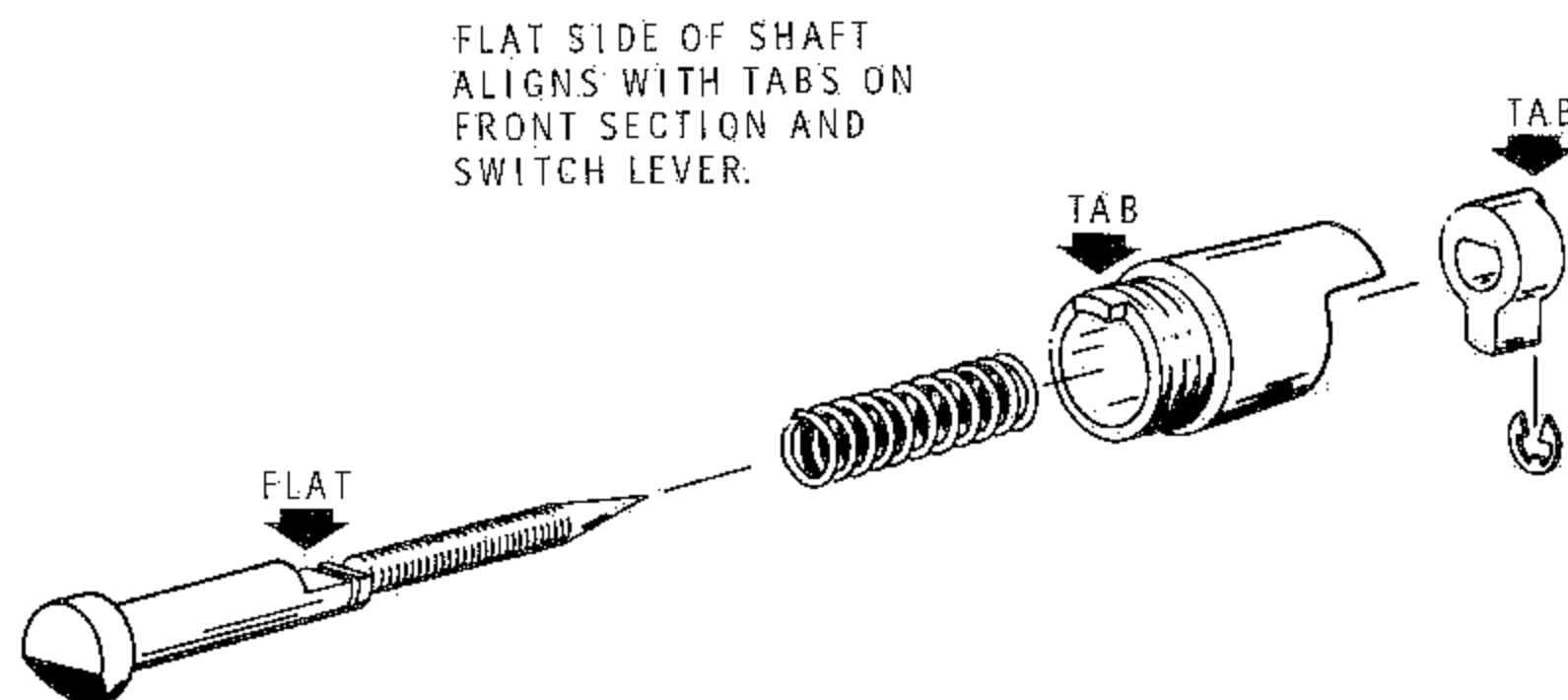

Detail 7C

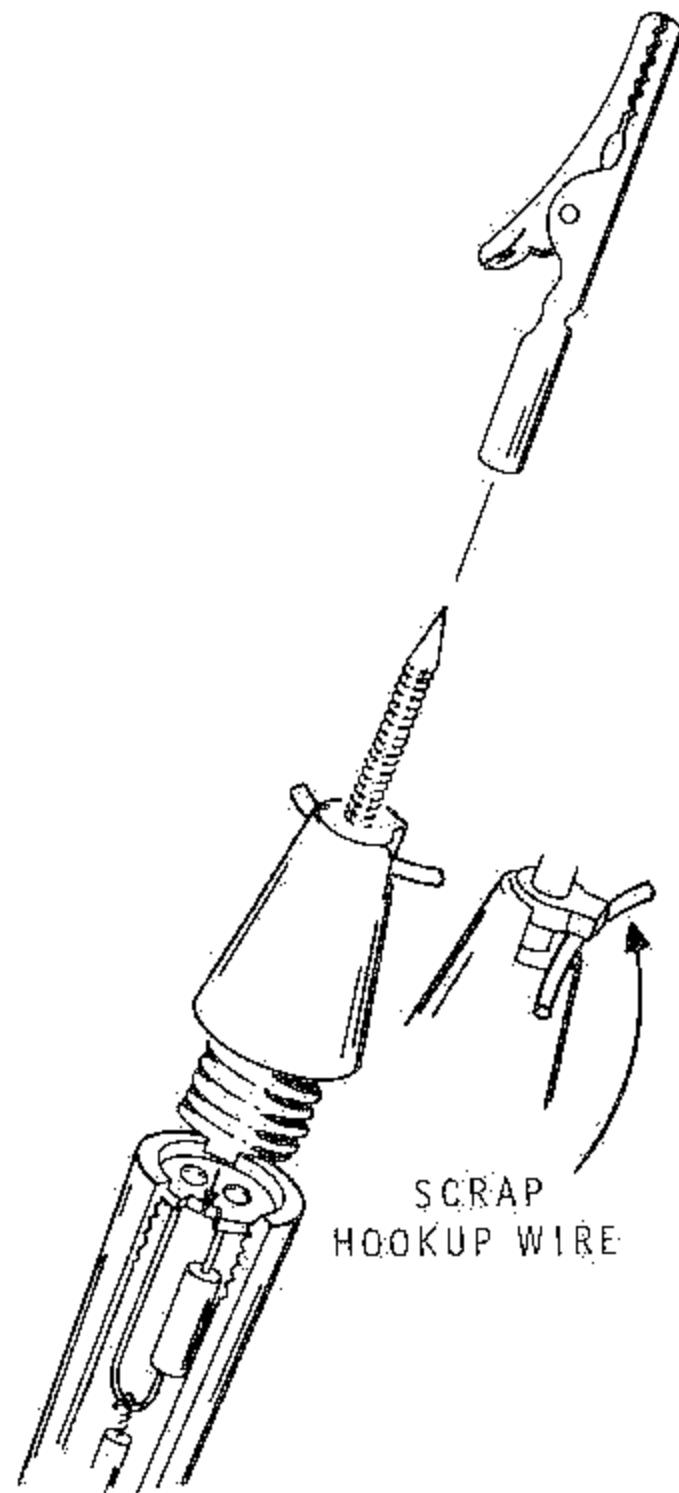

Detail 7E

Refer to Detail 7E for final assembly of the test probe.

- () Pull the switch lever forward against the spring tension and temporarily insert a scrap piece of hookup wire between the switch lever and the front section of the probe body.
- () Slip the center section of the probe body onto the shielded cable.
- () Gently pulling the shielded cable from the back of the center section, align the insert insulator flush with the front of the center section. Do not pull the insert insulator all the way into its final shoulder seat.

- () Insert the tab on the front section of the probe body into the notch in the insert insulator. Holding the front section stationary, screw the center section onto the front section, thus pushing the insert insulator down to its final seat. It is imperative that the final probe assembly be carried out in this manner; otherwise, proper connection between the rivet heads and the front section of the probe will not be made.

- () Remove the scrap hookup wire.

NOTE: If the gap between the front and middle sections is not considerably less than 1/16", the tab is not properly seated in the notch and the above steps must be repeated. Also, when properly assembled, the switch lever will noticeably "detent," or drop into place at both extreme switch positions.

- () Screw the alligator clip with threaded insert onto the probe spike as far as it will go.
- () Slip the rear section of the probe onto the cable and screw it onto the center section.

This completes the assembly of the test probe. The phone plug and alligator clip will now be assembled.

- () Route the free ends of both cables through the phone plug body.
- () Taking care not to cut the outer layer of very thin wires (shield), remove 1/2" of the outer insulator from the free end of the shielded test cable, as shown in Detail 8A.
- () Twist the shield wires lightly into one strand. Remove 1/4" of the inner insulation.
- () Remove 1/2" of insulation from one end of the black test cable. Now twist the shield wires of the shielded cable and the wires of the black cable firmly together into one strand and tin the combined strand heavily, as shown in Detail 8A. Also tin heavily the inner conducting wire. Take care not to melt the inner insulation.

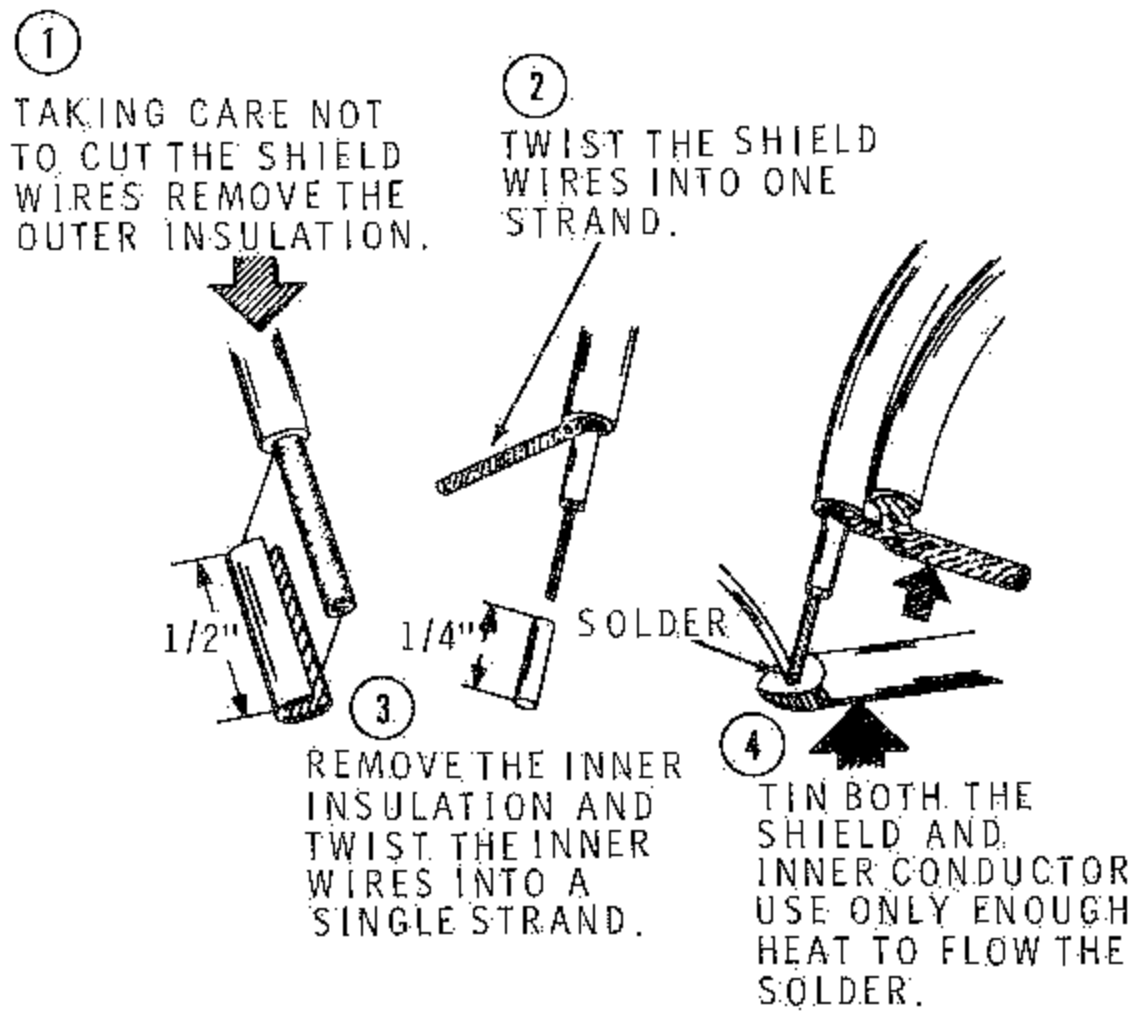

Detail 8A

In the following step, you will connect the prepared cables to the phone plug as shown in Pictorial 8. To avoid overheating the cable insulation, apply a film of solder to the phone plug and heat thoroughly. Then hold the heavily tinned wires to the phone plug and apply just enough heat to melt the solder.

() First, solder the two twisted wires to the phone plug. Be careful not to melt or burn the inner plastic insulation of the shielded cable. Then solder the inner conducting wire of the shielded cable as shown, being sure the phone plug body will still fit over the wires. Be sure to use only enough heat to melt the solder and make a good connection.

() After the wires have completely cooled down, use pliers to bend the tabs on the phone plug over lightly to secure the two cables. Be sure not to cut through the insulation by pinching the cables too hard with the tabs. Screw together the two parts of the phone plug.

This completes the phone plug assembly.

() Strip 1/2" of insulation from the free end of the black test lead, tin the strands of wire and solder to the alligator clip.

NOTE: The blue and white identification label shows the Model Number and Production Series Number of your kit. Refer to these numbers in any communications with the Heath Company; this assures you that you will receive the most complete and up-to-date information in return.

() Install the identification label in the following manner:

1. Select a location for the label where it can easily be seen when needed, but will not show when the unit is in operation. This location might be on the rear panel or the top of the chassis, or on the rear or bottom of the cabinet.
2. Carefully peel away the backing paper. Then press the label into position.

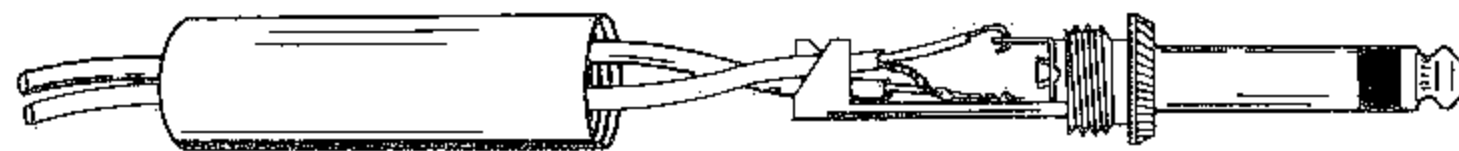

PICTORIAL 8

TEST AND CALIBRATION

During the preparation of the test leads and cabinet, the VTVM has had an opportunity to warm up thoroughly and should now be calibrated.

Turn the instrument off and make sure that the mechanical zero position of the meter pointer is correct. If not, adjust as before.

- () Turn the instrument on again.

ZERO ADJUST

- () Set the Function switch to DC+. Check operation of the ZERO ADJ control. Turning this control should move the meter pointer part way up scale. Set the pointer to zero at the left side of the scale and check for zero positioning when the Function switch is changed to DC-. It should be possible to obtain a ZERO ADJ control position that will permit the meter pointer to remain stationary when switching through from DC+ to DC-. If there is an appreciable zero shift of more than two divisions on the scale, it should be regarded merely as an indication that additional aging of the 12AU7 tube is required. This aging can be obtained by leaving the instrument turned on for a period of 48 hours or more, or through continued use of the VTVM with periodic calibration.

DC CALIBRATE

- () Insert the test lead phone plug. Set the Function switch to DC+, the Range switch to 1.5 V and the probe to DC. Connect the probe to lug 1 on the rear wafer of the Range switch (the point to which the blue cable wire is connected in Pictorial 4).
- () Adjust the DC Calibrate control so that the meter pointer falls directly over the very small red dot on the meter face. Approach the red dot going up scale by turning the screwdriver control and watch the meter read 1.4 volts, and 1.5 volts, and then the red dot. As soon as the red dot is reached, stop turning the DC Calibrate control. Remember that the Range switch must be set on 1.5 V for this adjustment.

OHMS CHECK

- () Set the Function switch to OHMS. Set the OHMS ADJ control for full scale (infinity). Set the probe switch to AC-OHMS (the position opposite the DC marking) and touch the probe to the common test clip. The meter pointer should drop to zero at the left end of scale (no resistance).

AC CALIBRATE

NOTE: Your AC power line outlets may be either 2-wire or 3-wire types. Determine which type you have and complete the appropriate AC Calibration instructions. Use the AC Calibrate With Line Cord Adapter for the 2-wire outlets and AC Calibrate Without Line Cord Adapter for the 3-wire outlets.

AC Calibrate With Line Cord Adapter

- () Install the line cord adapter on the line cord.
- () Temporarily remove the phone plug from the jack.
- () Set the Range switch to 1.5 V and the Function switch to AC.
- () Adjust the AC Balance control so no movement is detected when switching from AC through DC- to DC+.
- () Set the Range switch to the 150 V range if you wired your VTVM for 120 VAC operation, or to the 500 V range if you wired the VTVM for 240 VAC operation.
- () Set the Function switch to AC.
- () Set the AC Calibrate control fully clockwise.
- () Reinsert the phone plug.
- () Set the switch on the test probe to AC.
- () Connect the test probe to one side of the AC line and then the other side. Note the lowest reading and remove the probe from the AC line.



- () Now connect the negative meter lead to the side of the AC line with the lowest reading. Then connect the test probe to the other side of the line.
- () Adjust the AC Calibrate control until the meter pointer indicates the line voltage.
- () Disconnect the test lead and probe.

AC CALIBRATE WITHOUT LINE CORD ADAPTER

CAUTION: Do NOT use the common (negative) lead of the VTVM when measuring power line voltages. This lead is already connected to the circuit ground and to the power line ground. If the common lead should contact the "hot" side of the power outlet, the power line will be short-circuited. Connect ONLY the meter probe, set on AC, to the power line.

- () Temporarily remove the phone plug from the jack.
- () Set the Range switch to 1.5 V and the Function switch to AC.
- () Adjust the AC Balance control so no movement is detected when switching from AC through DC- to DC+.
- () Set the Range switch to the 150 V range if you wired your VTVM for 120 VAC operation, or to the 500 V range if you wired the VTVM for 240 VAC operation.
- () Set the Function switch to AC.
- () Set the switch on the test probe to AC.
- () Reinsert the phone plug.

- () Connect the test probe to the side of the AC line with the highest reading.
- () Adjust the AC Calibrate control until the meter pointer indicates the line voltage.

AGING AND FINAL CALIBRATION

- () It is recommended that the tubes be aged before final calibration. This is accomplished by keeping the instrument turned on for a period of at least 48 hours. Final calibration should be done in the same way as the initial calibration. Careful calibration will result in a more accurate instrument. If a standard AC meter is available, it is desirable to use such an instrument to check the accuracy of the VTVM. Preferably, use a voltage near full scale on the VTVM as for instance, 140 volts or 40 volts on the 150 V or 50 V range respectively. The DC scales may also be calibrated using a DC meter of known accuracy. One of the major advantages of kit form instrument assembly is that the kit builder becomes thoroughly familiar with the calibration procedure and is therefore capable of periodically checking VTVM operating accuracy, instead of assuming that usual factory instrument calibration is still valid.

After final calibration, place the instrument in the cabinet and secure it with two 6-32 x 3/8" sheet metal screws. The instrument is now ready for use. The power consumption of the VTVM is very low and there is no objection to leaving the instrument on continuously during the daily work period rather than turning it off each time a measurement function is completed. Daily operation for a period of several hours or more will also serve the purpose of minimizing possible moisture accumulation.

USING YOUR VTVM

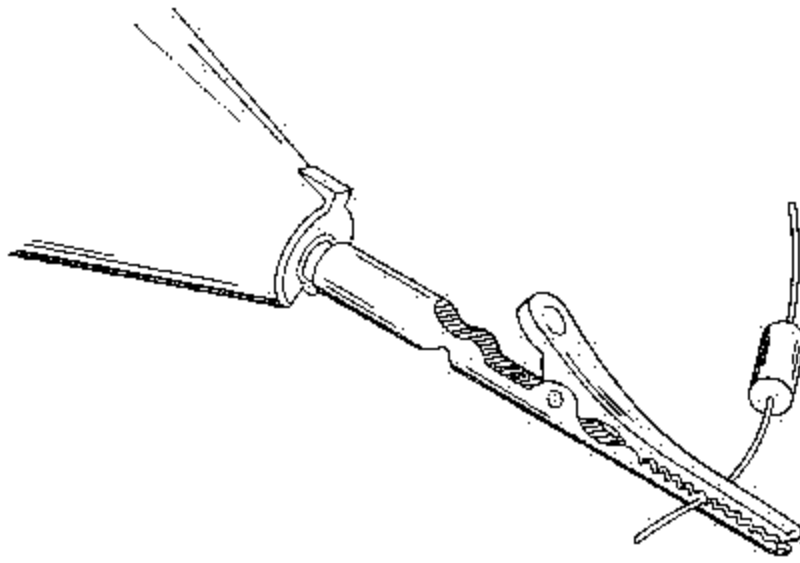

Figure 1

COMBINATION PROBE

The combination AC-OHMS-DC test probe eliminates two of the usual three test jack installations in the VTVM front panel. The probe is set to AC-OHMS (the position opposite the DC marking) when the Function switch is on AC or OHMS, and on DC when the Function switch is on DC+ or DC-. The probe tip design makes it unnecessary to actually hold the probe to the circuit. Instead, the probe can be clipped onto any lead in the circuit, as shown in Figure 1, giving the operator another free hand.

CAUTION: It is good practice to observe certain basic rules of operating procedure anytime voltage measurements are to be made. Always handle the test probe by the insulated housing only and do not touch the exposed tip portion.

The metal case of this instrument is connected to the ground of the internal circuit and, through the green line cord wire, to the power line ground. For proper operation, the ground terminal of the instrument should ALWAYS be connected to the ground of the equipment under test. There is always danger inherent in testing electrical equipment and therefore the user should clearly familiarize himself with the equipment under test before working on it, bearing in mind that high voltages may appear at unexpected points in defective equipment.

When measurements are to be made at high voltage points, it is good practice to remove operating power before connecting test leads. If this is not possible, be particularly careful

to avoid accidental contact with nearby objects which could provide a ground return path. When working on high voltage circuits, play safe. Keep one hand in your pocket to minimize accidental shock hazard and be sure to stand on a properly insulated floor or floor covering.

DC VOLTAGE MEASUREMENTS

The VTVM has many advantages over nonelectronic volt-ohmmeters. The greatest advantage is the high input resistance. This enables much more accurate readings to be obtained in high impedance circuits such as resistance coupled amplifiers, oscillator grid circuits, and AVC lines.

To illustrate this, assume a resistance coupled audio amplifier with a .5 megohm plate load resistor operating from a 100 volt plate supply as shown in Figure 2. Assume that the plate voltage is 50 volts and therefore the tube acts as a .5 megohm resistor. Measuring the plate voltage with a conventional 1000 ohms-per-volt instrument on the 100 volt scale, the meter can be considered a 100,000 Ω (.1 megohm) resistor in parallel with the tube. The voltage on the plate is then about 14 volts, and is shown as such by the meter. This is due to the shunt resistance of the low resistance meter. Using the VTVM on any scale setting, the full 11 megohms is placed in parallel with the tube. The voltage on the plate is then about 49 volts or 2% lower than the normal operating voltage. More accurate readings can thus be obtained with the high resistance provided by an electronic voltmeter.

To measure DC voltage with the VTVM, connect the COMMON (black lead) to the common or "cold" side of the voltage to be measured. Set the Function switch to DC+ or DC- as required and set the Range switch to a range greater than the voltage to be measured, if known. If unknown, set to 1500 V. With the test probe set on DC, touch the "hot" side of the voltage to be measured. If the pointer moves less than 1/3 of full scale, switch the Range switch to the next lower range. For greatest measurement accuracy, all voltage measurements should be made on the range which will accommodate the largest possible deflection of the meter pointer.

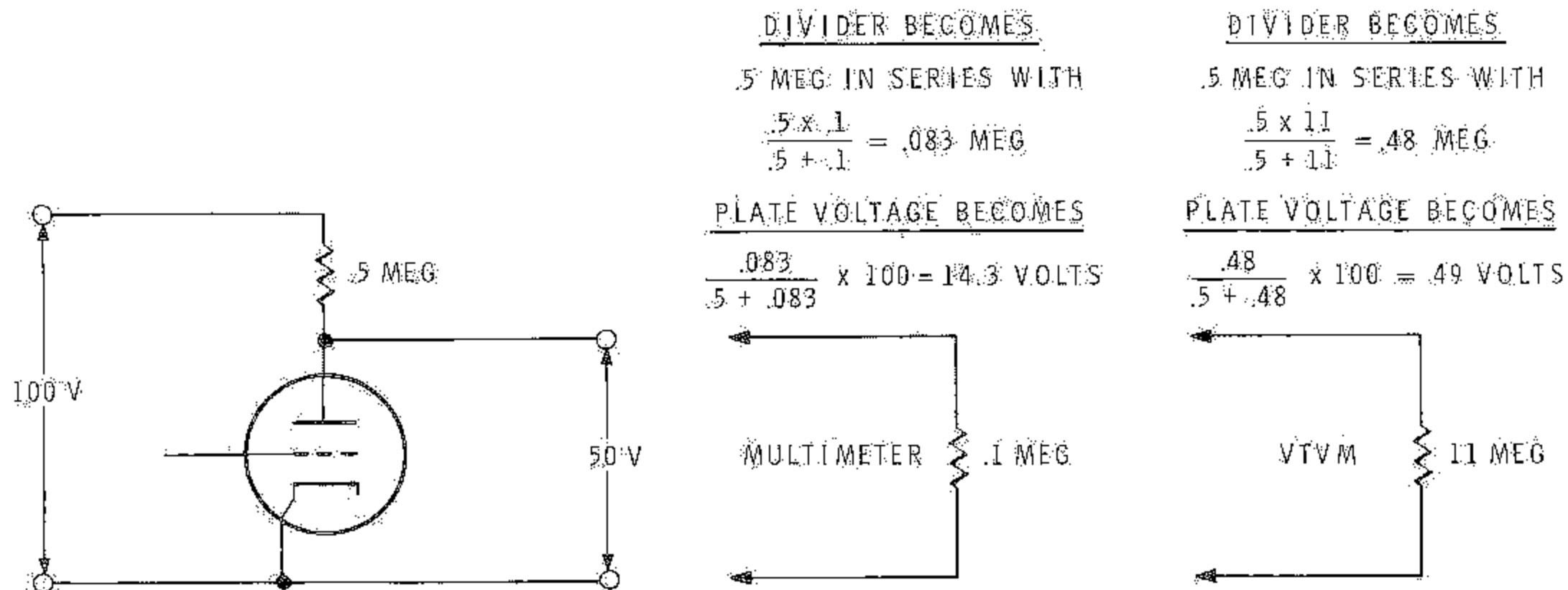

Figure 2

The available voltage ranges are intended to provide coverage for the radio and TV serviceman. For example, the 1.5 V range will be useful in measuring bias voltages, DC heater voltages, etc. The 5 V and 15 V ranges will again prove their worth in bias measurement functions. The 50 V and 150 V ranges will find greatest application in the measurement of voltages encountered in universal or transformerless type radio circuits. The 500 V range can be used on conventional transformer operated power supplies found in radio and TV circuits, and this voltage range eliminates the necessity for switching from one range to another when measuring plate and screen supply voltages. On many occasions, the higher voltage ranges will prove useful.

DC accelerating potentials developed in TV receiver flyback power supply systems can be safely measured through the use of the HEATHKIT High Voltage Probe in conjunction with the VTVM. This probe with its precision multiplier resistor mounted in a safety plastic probe housing will provide a multiplication factor of 100 for the VTVM DC ranges. 30,000 volts DC is generally considered the safe upper limit for these measurements.

CENTER SCALE "0" POSITION

Your VTVM features a convenient center scale zero position. The adjustment range of the ZERO ADJ control will permit center scale zero

deflection of the meter pointer when Function switch is set to DC+ or DC-. Center scale zero may not be obtained at both positions.

The center scale zero will be useful as a null indicator in discriminator adjustments, for bias measurements or any application where polarity reversals may occur.

AC VOLTAGE MEASUREMENTS

Power Line Measurements

CAUTION: When you measure the power line voltage from a 3-wire grounded system, do NOT use the common (negative) lead of the VTVM. This lead is already connected through the green lead of the 3-wire line cord to the power line ground. If you should touch this common lead to the "hot" side of the power outlet, the power line will be short circuited. Connect ONLY the meter probe, set on AC, to the power line. If there is no meter indication, connect the probe to the other side of the power line.

If you use a 2-wire system, use the adapter plug supplied with the VTVM.

If you have occasion to measure a 240 volt, 3-wire, AC power line, you will get a meter indication at two of the three connections. The connection which produces no meter reading is the common side of the power line. Add together the voltages at the other two connections to determine the line voltage.



Other AC Voltages

To measure AC voltage, connect the COMMON (black) lead to the common or "cold" side of the voltage to be measured. Set the Function switch to AC and set the range switch to a range greater than the voltage to be measured, if known. If unknown, set to 1500 V. With the test probe set on AC, touch the other side or "hot" side of the voltage to be measured. If the meter moves less than 1/3 of full scale, switch to the next lower range. The maximum AC voltage that can be safely measured is 1500 volts, and this limit must not be exceeded. The meter scales are calibrated in both rms and peak-to-peak voltages. When values of sine waves are measured, rms voltages are read and the corresponding values in peak-to-peak volts are equal to 2.83 times the rms voltage. If the range switch is set at 15 V and a sine wave of 10 rms volts is applied to the instrument, the meter pointer will indicate 10 rms volts and 28.3 peak-to-peak volts. This direct-reading, time-saving feature makes the usual calculation to transpose from one scale to another unnecessary.

This VTVM is an extremely sensitive electronic AC voltmeter and as the human body picks up AC when near any AC wires, the meter will indicate this pickup. Never touch the probe when on the lower ranges. Zero should be set with the probe shorted to the common clip. Then switch back and forth between DC- and DC+.

RESISTANCE MEASUREMENTS

To measure resistance with the VTVM, connect the COMMON (black) lead to one side of the resistor or circuit to be measured. Set the Function switch to OHMS and set the Range switch to a range that will provide a reading as near mid-scale as possible. Set the OHMS ADJ control so the meter indicates exactly full scale (infinity). With the test probe set on OHMS, touch the other side of the resistor or circuit to be measured. Read resistance on the OHMS scale and multiply by the proper factor as shown by the Range switch settings.

NOTE: Although a battery is used to measure resistance, the indication is obtained through the electronic meter circuit and therefore the VTVM must be connected to the AC power line and turned on. Establish the habit of never leaving the instrument set in the OHMS position as this could greatly shorten the life of the ohmmeter battery, particularly if the test leads are accidentally shorted together when lying on the service bench.

USING THE DECIBEL SCALE

Because the human ear does not respond to volume of sound in proportion to signal strength, a unit of measure called the "bel" was adopted. The bel is more nearly equivalent to human ratios. Normally the reading is given in 1/10 of a bel or a decibel. Various signal levels are adopted by various manufacturers as standard of zero decibel. The VTVM DB scale (decibel) uses a standard of 1 milliwatt into a 600 Ω load as zero decibels. This corresponds to .774 volts AC on the 1.5 V scale. From this figure, the various AC ranges of the VTVM may be converted to DB, with adequate accuracy, by the following chart:

<u>AC VOLTS SCALE</u>	<u>DECIBEL SCALE</u>
0-1.5 volts	Read db directly
0-5 volts	Add 10 db to the reading
0-15 volts	Add 20 db to the reading
0-50 volts	Add 30 db to the reading
0-150 volts	Add 40 db to the reading
0-500 volts	Add 50 db to the reading
0-1500 volts	Add 60 db to the reading

As the decibel is a power ratio or voltage ratio, it may be used as such without specifying the reference level. Thus for instance, a fidelity curve may be run on an amplifier by feeding in a signal of variable frequency but constant amplitude. At a reference frequency of say 400 cps, adjust the input to give a convenient indication (zero db, for instance) on the VTVM connected to the output. As the input frequency is varied, the output variation may be noted directly in DB above and below the specified reference level.

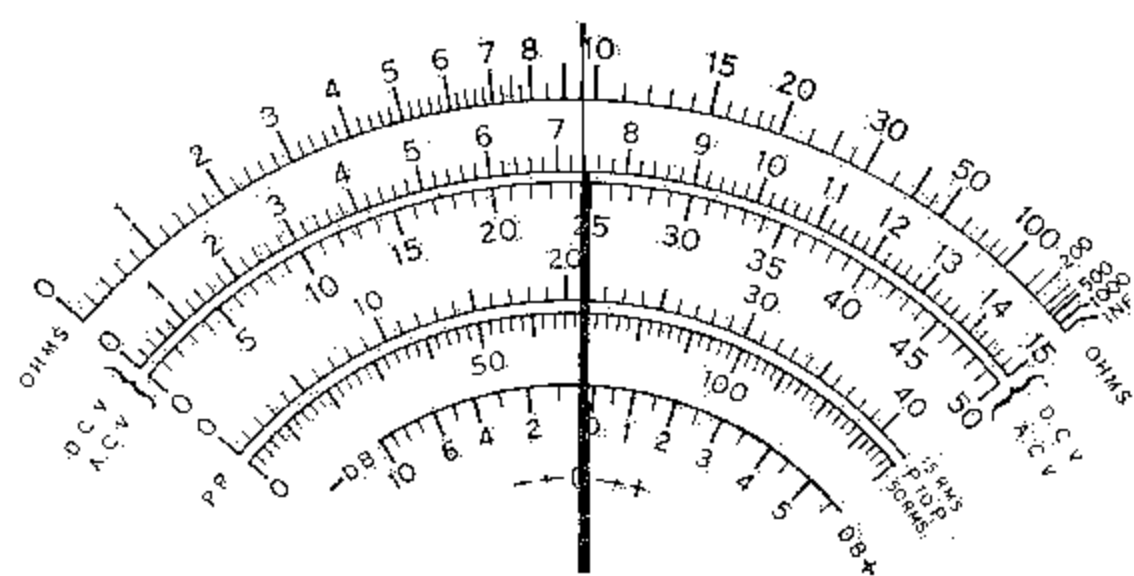

READING THE METER SCALE

The voltage markings for the Range switch refer to the full scale reading. The scale is marked 0-15 and 0-50 for voltage. On the 1.5 V range, read the 0-15 scale and move the decimal one place to the left. Thus for example, a reading of 8 would represent a voltage of .8 volt. On the 5 V range, read the 0-50 scale and move the decimal point one place to the left, that is, drop the zero. A reading of 40 would represent a voltage of 4 volts. On the 15 V range, read the 0-15 scale directly. EXAMPLE: A reading of 4 represents a voltage of 4 volts. On the 50 V range, read the 0-50 volts directly. On the 150 V range, read the 0-15 scale and add one zero. EXAMPLE: A reading of 12 represents a voltage of 120 volts. On the 500 V range, read the 0-50 scale and add one zero. EXAMPLE: A reading of 40 represents a voltage of 400 volts. On the 1500 V range, read the 0-15 scale and add two zeros. EXAMPLE: A reading of 8 represents a voltage of 800 volts.

NOTE: The meter markings do not mean that the upper scale indicates DC volts and the lower scale AC volts. Rather, it means that either scale will read AC volts or DC volts, depending on the setting of the Function switch.

The resistance marking or OHMS scale refers to the lowest resistance range, RX1. For the other ranges, add the proper number of zeros. Add two zeros for RX100, four zeros for RX10K and six zeros for RX1 MEG. On the RX1 MEG range, the scale can also be considered to read directly in megohms.

ACCURACY

The accuracy of the meter movement is within 2% of full scale which means that on the 1500 V range, for instance, the accuracy of the movement will be within 30 volts at any point on the scale. On DC, the accuracy of the multipliers (1%) may be additive, resulting in an accuracy of within 3% of full scale.

On AC, the accuracy of the rectifier circuit contributes variations which result in an accuracy of within 5% of full scale. Bear in mind that on the lowest AC voltage range, 1.5 V extreme sensitivity will introduce additional variation through stray pickup. Therefore, on the 1.5 V range, it is possible that the accuracy may be in the order of 15% on AC only.

The accuracy on the OHMS range depends on the meter accuracy, the ohms multiplier accuracy (including the internal resistance of the battery) and the stability of the battery voltage. On the RX1 scale, the internal resistance of the battery and the battery voltage both vary as a result of the current drawn by the resistance under test. For greatest accuracy, tests on low resistance values should be made as quickly as possible.

On the higher ohms range, the accuracy depends practically on the multipliers which are 1% and the meter movement accuracy, 2%. Because of the nonlinear OHMS scale, the resulting accuracy is not readily expressed in a percentage figure, but greatest accuracy is obtained at mid-scale readings.

NOTE: When comparing this instrument with another VTVM, consider that the accuracy of the other instrument may deviate in the opposite direction. Therefore, when comparing two instruments of 5% accuracy, the total difference may be 10%. Critical comparisons should only be made against certified laboratory standards.

IN CASE OF DIFFICULTY

1. Recheck the wiring. Trace each lead in colored pencil on the Pictorial as it is checked. It is frequently helpful to have a friend check your work. Someone who is not familiar with the unit may notice something consistently overlooked by the constructor.
2. It is interesting to note that about 90% of the kits that are returned for repair, do not function properly due to poor connections and soldering. Therefore, many troubles can be eliminated by reheating all connections to make sure that they are soldered as described in the Proper Soldering Techniques section of this manual.
3. Check to be sure that all tubes are in their proper locations. Make sure that all tubes light up properly.
4. Check the tubes with a tube tester or by substitution of tubes known to be good.
5. Check the values of the component parts. Be sure that the proper part has been wired into the circuit, as shown in the pictorial diagrams and as called out in the wiring instructions.
6. Check for bits of solder, wire ends or other foreign matter which may be lodged in the wiring beneath the chassis.
7. If, after careful checks, the trouble is still not located and a voltmeter is available, check voltage readings against those found on the Schematic Diagram. NOTE: All voltage readings were taken with an 11 megohm input vacuum tube voltmeter. Voltages may vary as much as 10% due to line voltage variations.
8. A review of the Circuit Description will prove helpful in indicating where to look for trouble.

Refer to the Kit Builders Guide for Service And Warranty information.



TROUBLESHOOTING CHART

COMPLETELY INOPERATIVE

1. Make sure that power is being applied to the instrument. This may be measured across the primary winding of the power transformer (black lead to black-red lead).
2. If pilot lamp and tube filaments do not light, check voltage between the yellow leads of power transformer (5-6 volts AC).
3. Check voltage between each end of electrolytic capacitor and ground. Correct voltages are shown on the Schematic.
4. Check the 12AU7 tube.

INABILITY TO OBTAIN DC BALANCE

1. Check the 12AU7 tube for an unbalanced condition (Substitution).
2. Check the two .005 capacitors C5 and C6 (Pins 2 and 7 of the 12AU7).
3. Check the components in the cathode circuits of the 12AU7 tube (Pins 3 and 8). These circuits include the ZERO ADJ control, R1, R33, R34, and R35.
4. Check Range switch assembly carefully.

AC INOPERATIVE

1. Check the 6AL5 tube.
2. Check C2, .047 μ fd 1600 volt, and the two .02 μ fd capacitors, C3 and C4.
3. Check Function switch assembly carefully.

AC BALANCE

1. Disconnect test leads from instrument before adjusting the AC Balance control as directed in the manual.
2. It is imperative that DC balance be obtained before this adjustment is made.

INACCURATE AC READINGS (The inability to obtain AC calibration).

1. Check capacitors C2, C3, and C4.
2. Check the 6AL5 tube.
3. Check the AC Calibrate control, R3. NOTE: With the test lead plug inserted, there may be a residual reading. This is due to stray AC pickup in the test leads. Readings on the two lower AC ranges will normally be low.

INACCURATE DC READINGS

1. Check the DC calibrate control, R4.
2. Check resistor in the test probe. Make sure that it is not being grounded.

OHMS INOPERATIVE

1. Check the OHMS ADJ control, R2, for correct value.
2. Check Range switch for proper assembly.
3. Check the battery.

OHMS INACCURATE

1. Check the battery (Substitution).
2. Check the value of all resistors on the range switch which have a value beginning with the number "9". (The 9.1 Ω R31 should receive special attention.) NOTE: The ohms section of the VTVM is not intended for use as a standard. Where a great degree of accuracy is required, a bridge should be used.

MAINTENANCE

METER

Because of the delicate nature of the meter movement, no attempt should be made to repair the meter. Such attempts would automatically void the standard warranty coverage of the meter itself.

METER COVER

If the polystyrene meter cover is accidentally damaged, a replacement cover only is available from the Heath Company. This cover can be easily removed without detaching the meter from the panel. Use a small screwdriver or knife blade under one of the upper corners and pop off the friction-fit cover. When installing a new cover, precaution should be observed regarding proper engagement of the mechanical zero adjust stud. If it is necessary to expose the meter movement to air for a period of time, protect the movement from foreign matter, dust, etc., by enclosing the instrument in a box or possibly in a desk drawer.

ELECTROSTATIC CHARGE

The polystyrene meter cover has been treated to resist an accumulation of static electricity. However, should a static charge accumulate through repeated polishing or cleaning of the meter cover, the pointer will deflect in an erratic manner, regardless of whether the instrument is turned off or on. This condition can be corrected quickly. Apply a small quantity of liquid dishwashing detergent to a clean, soft

cloth and wipe the surface of the meter cover. The accumulated electrostatic charge will immediately disappear. It is not necessary to remove the cover for this correction.

CHECKING METER COIL CONTINUITY

When checking for meter coil continuity, ALWAYS use a resistor of at least 10 K Ω in series with the meter movement and the ohm-meter test leads. If this resistor is not used to reduce the current, the meter movement will probably be seriously damaged.

TEST LEADS

Because of their constant flexing during use, the test leads are not above suspicion, especially when the VTVM has been in use for several years. Erratic or improper DC voltage measurements can sometimes be caused by a fault in the shielded test lead or in the connection of the 1 megohm isolating resistor used in the test probe.

CIRCUIT BOARD

The Model R-V7A Circuit Board Repair Kit is available from the Heath Company. This repair kit contains a new circuit board plus all circuit board-mounted parts that cannot be salvaged easily from the original board. The price of this repair kit is \$3.00.

ACCESSORY PROBES

HIGH VOLTAGE TEST PROBES

A high voltage test probe is available from the Heath Company. This probe will permit VTVM DC measurements up to 30,000 volts, which covers the range of flyback power supply voltages commonly encountered in TV receivers. This probe consists of red molded housing with black molded handle. It contains a 2% precision, 1090 megohm resistor and provides a DC range multiplication factor of 100 for 11 megohm input VTVMs.

Older model high voltage probes may be converted for use in the IM-18 by making a ground

connection from an alligator clip lead to the body of the probe phone plug.

RF TEST PROBE

A RF test probe is available from the Heath Company. This probe will permit VTVM usage for RF measurements up to 30 volts, substantially flat from 1000 cps to 100 mc. A built-in isolating capacitor permits DC voltage range up to 500 volts. It uses a printed circuit board for easy assembly and its housing is of polished aluminum with polystyrene insulation.



REPLACEMENT PARTS PRICE LIST

PART No.	PRICE Each	DESCRIPTION	PART No.	PRICE Each	DESCRIPTION
RESISTORS			TUBES-LAMPS		
1-3	.10	100 Ω 1/2 watt	411-25	1.20	12AU7 tube
1-20	.10	10 K Ω 1/2 watt	411-40	.90	6AL5 tube
1-23	.10	27 K Ω 1/2 watt	412-4	.15	#50 pilot lamp
1-27	.10	150 K Ω 1/2 watt	SOCKETS		
1-29	.10	220 K Ω 1/2 watt	434-47	.15	Pilot lamp socket
1-35	.10	1 megohm 1/2 watt	434-79	.15	9-pin tube socket
1-38	.10	3.3 megohm 1/2 watt	434-112	.10	7-pin tube socket
1-40	.10	10 megohm 1/2 watt	WIRE-SLEEVING		
1-70	.10	22 megohm 1/2 watt	89-23	.75	Line cord
3-4-2	.25	91, Ω 5% precision 2 watt	340-2	.05/ft	#20 bare wire
2-24	.20	90 Ω 1/2 watt precision	341-1	.05/ft	Black test lead
2-29	.20	900 Ω 1/2 watt precision	343-11-1	.20	Shielded test lead
2-35	.20	9 K Ω 1/2 watt precision	344-59	.05/ft	Hookup wire
2-50	.20	10 K Ω 1/2 watt precision	347-1	.10/ft	8-wire cable harness
2-38	.20	20 K Ω 1/2 watt precision	346-1	.05/ft	Insulating sleeving
2-9	.20	70 K Ω 1/2 watt precision	346-6	.05/ft	Fiberglass sleeving
2-41	.20	90 K Ω 1/2 watt precision	SHEET METAL PARTS		
2-86	.20	150 K Ω 1/2 watt precision	90-412	2.70	Cabinet
2-54	.20	200 K Ω 1/2 watt precision	203-278-2	.70	Front panel
2-87	.20	320 K Ω 1/2 watt precision	204-873	.45	Bracket assembly
2-13	.25	700 K Ω 1/2 watt precision	214-2	.15	Battery housing cup
2-51	.20	900 K Ω 1/2 watt precision	204-84	.10	Support bracket
2-55	.20	2 megohm 1/2 watt precision	HARDWARE		
2-16	.40	7 megohm 1/2 watt precision	250-8	.05	#6 sheet metal screw
2-52	.35	9 megohm 1/2 watt precision	250-89	.05	6-32 x 3/8" screw
2-28-1	.35	900 K Ω precision 1 watt	250-56	.05	6-32 x 1/4" screw
CAPACITORS			250-83	.05	#10 x 1/2" sheet metal screw
21-27	.10	.005 μ fd 400 V disc ceramic	252-3	.05	6-32 nut
21-31	.10	.02 μ fd 400 V disc ceramic	252-7	.05	Control nut
23-91	.50	.047 μ fd 1600 V tubular	253-2	.05	#6 fiber shoulder washer
25-5	.55	16 μ fd 150 V electrolytic	253-3	.05	#10 fiber flat washer
CONTROLS-SWITCHES			253-10	.05	Control flat washer
10-78	.45	15 K Ω control	254-4	.05	Control lockwasher
10-38	.35	10 K Ω control	254-1	.05	#6 lockwasher
63-500	3.40	Range switch	259-1	.05	#6 solder lug
63-501	2.80	Function switch			

PART No.	PRICE Each	DESCRIPTION
----------	------------	-------------

PROBE PARTS

A factory-wired and tested replacement probe assembly, Model PKW-4, is available from Heath Company at \$4.95 plus postage. Due to the cost of handling, the replacement probe assembly is not available in kit form.

4.95

MISCELLANEOUS

54-23-24	2.50	Power transformer
57-27	.60	Silicon diode
75-30	.10	Strain relief, round cord
75-71	.10	Strain relief, flat cord
85-9-1	1.65	Circuit board
211-15	.20	Handle
258-7	.10	Battery spring
260-1	.15	Alligator clip
260-51	.20	Alligator clip, threaded
261-4	.05	Rubber foot
407-62	7.75	200 microampere meter and hardware

PART No.	PRICE Each	DESCRIPTION
----------	------------	-------------

Miscellaneous (cont'd.)

432-27	.40	Line cord adapter
432-67	.10	Solderless connector
436-20	.45	Phone jack
438-28	.65	Phone plug
455-50	.10	Knob bushing
462-245	.25	Knob
490-5	.10	Plastic nut starter
331-6	.15	Solder
	2.00	Manual (See front cover for part number.)

The above prices apply only on purchases from the Heath Company where shipment is to a U.S.A. destination. Add 10% (minimum 25 cents) to the price when ordering from an authorized Service Center or Heathkit Electronic Center to cover local sales tax, postage and handling. Outside the U.S.A. parts and service are available from your local Heathkit source and will reflect additional transportation, taxes, duties and rates of exchange.

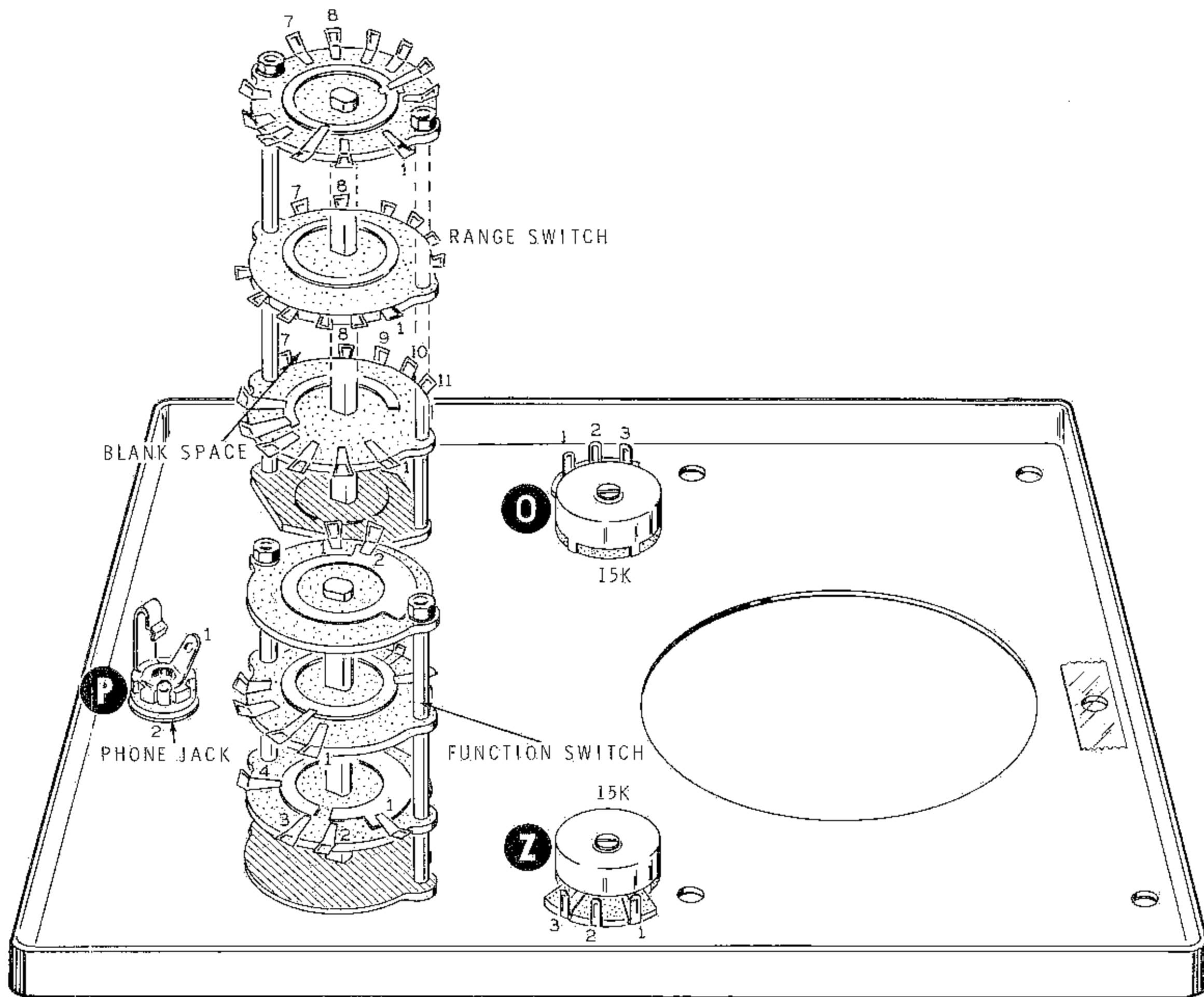

PICTORIAL 1

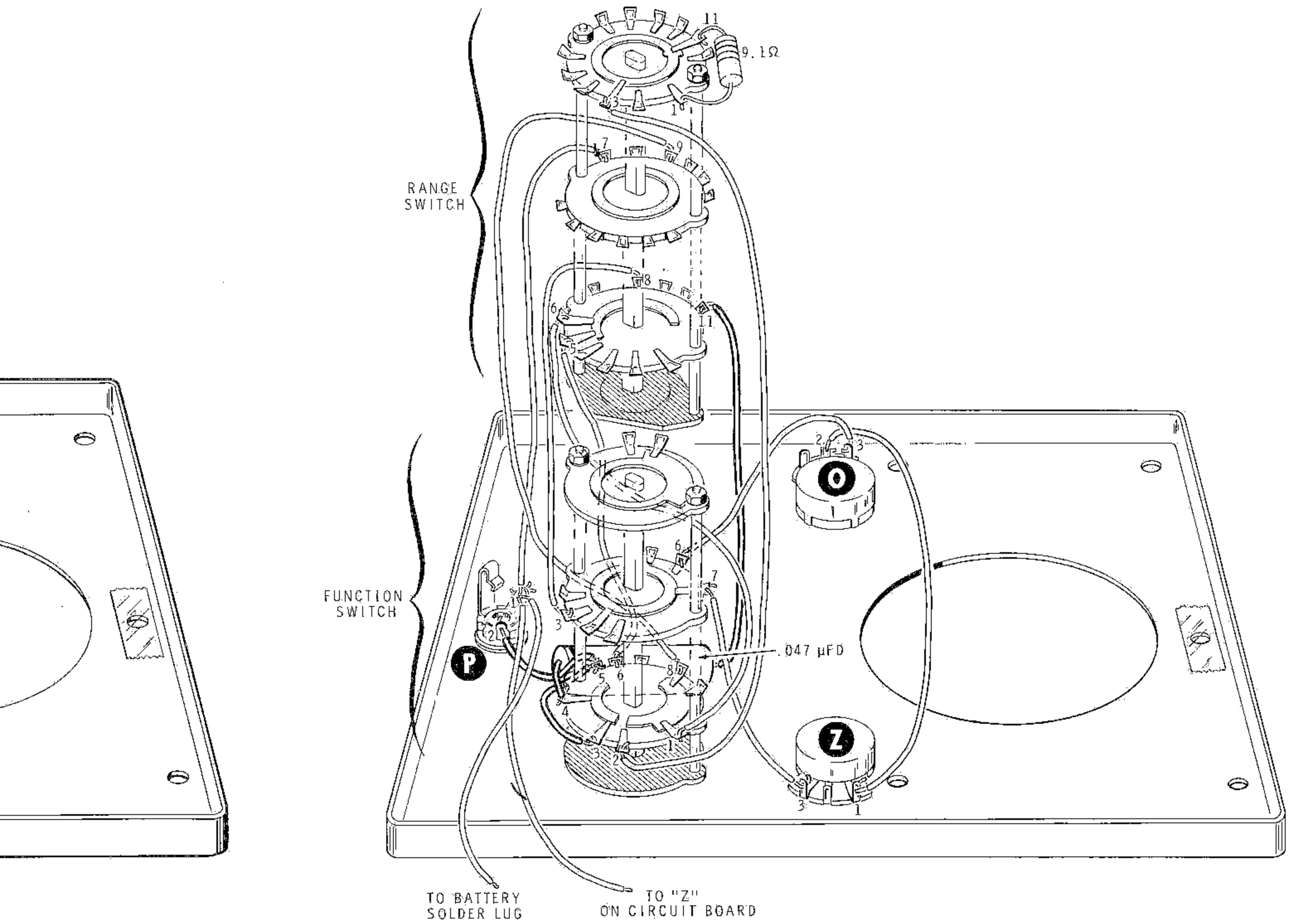

PICTORIAL 2

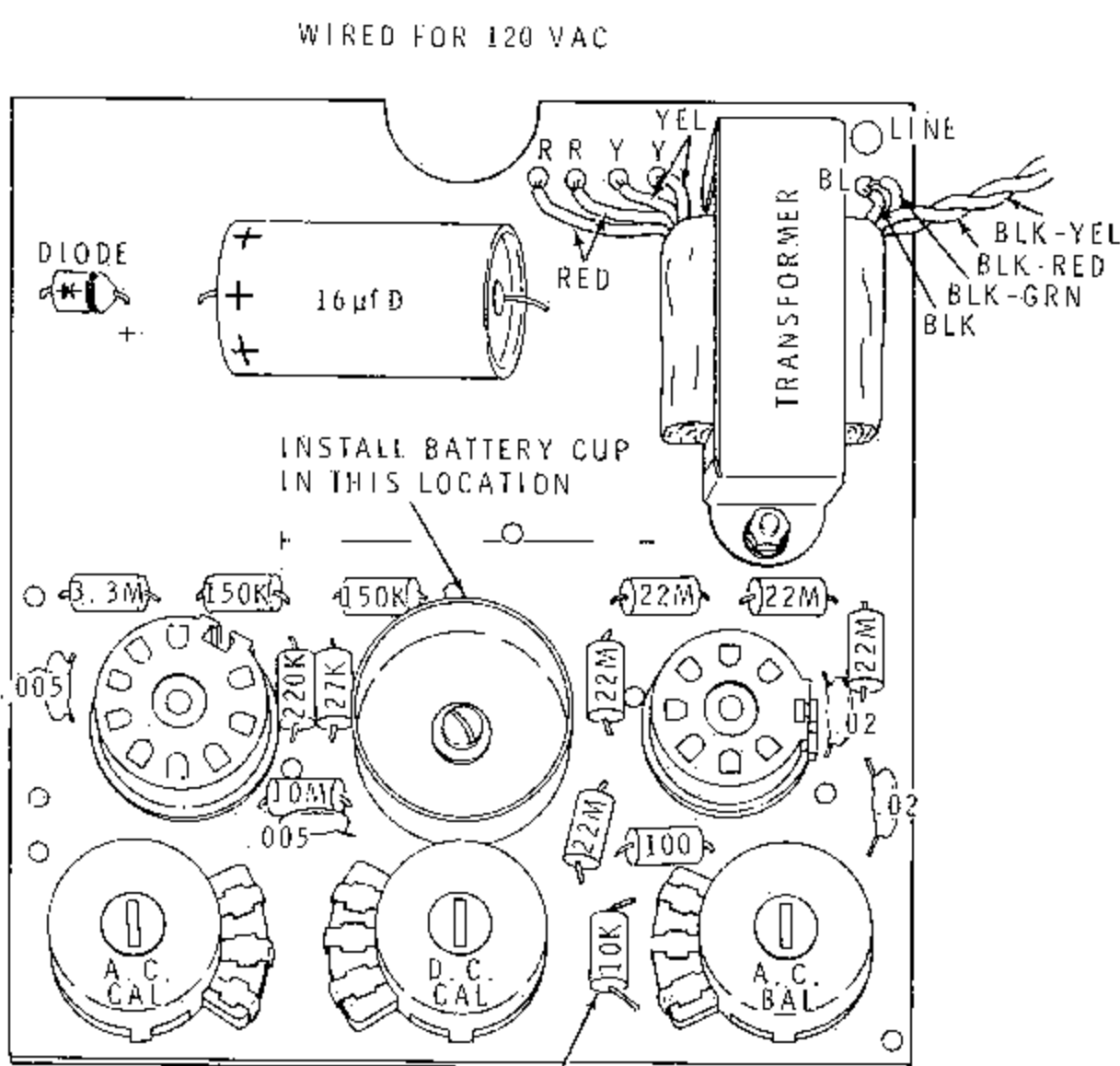

NOTE: DRESS THE 10K RESISTOR SLIGHTLY TO THE LEFT SO IT WILL CLEAR THE POTENTIOMETER TERMINALS.

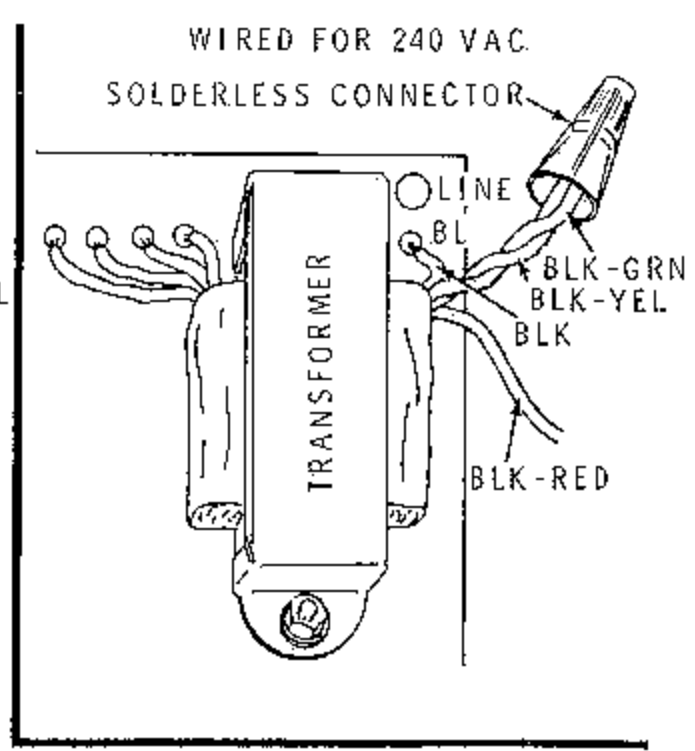

PICTORIAL 3

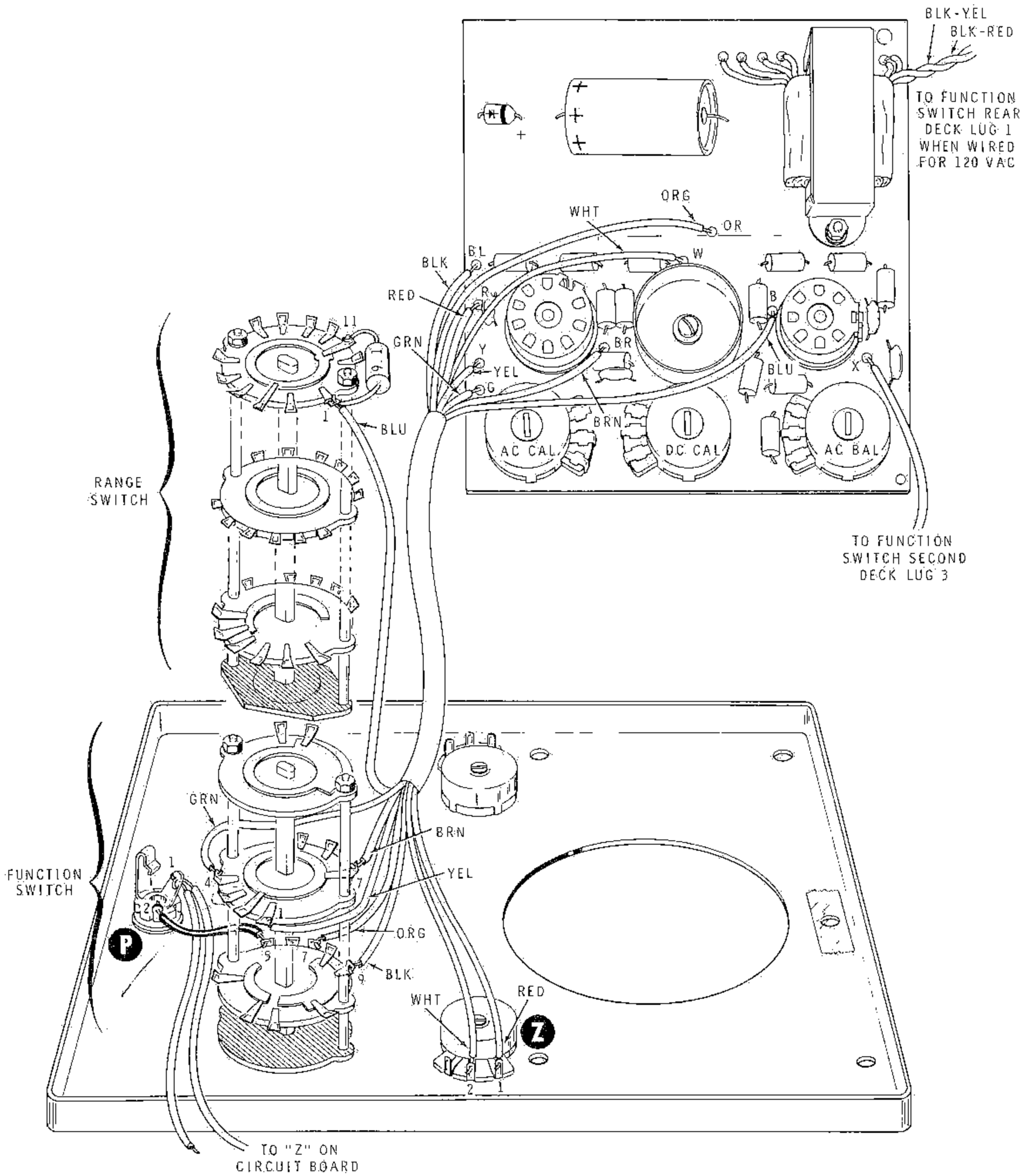

PICTORIAL 4

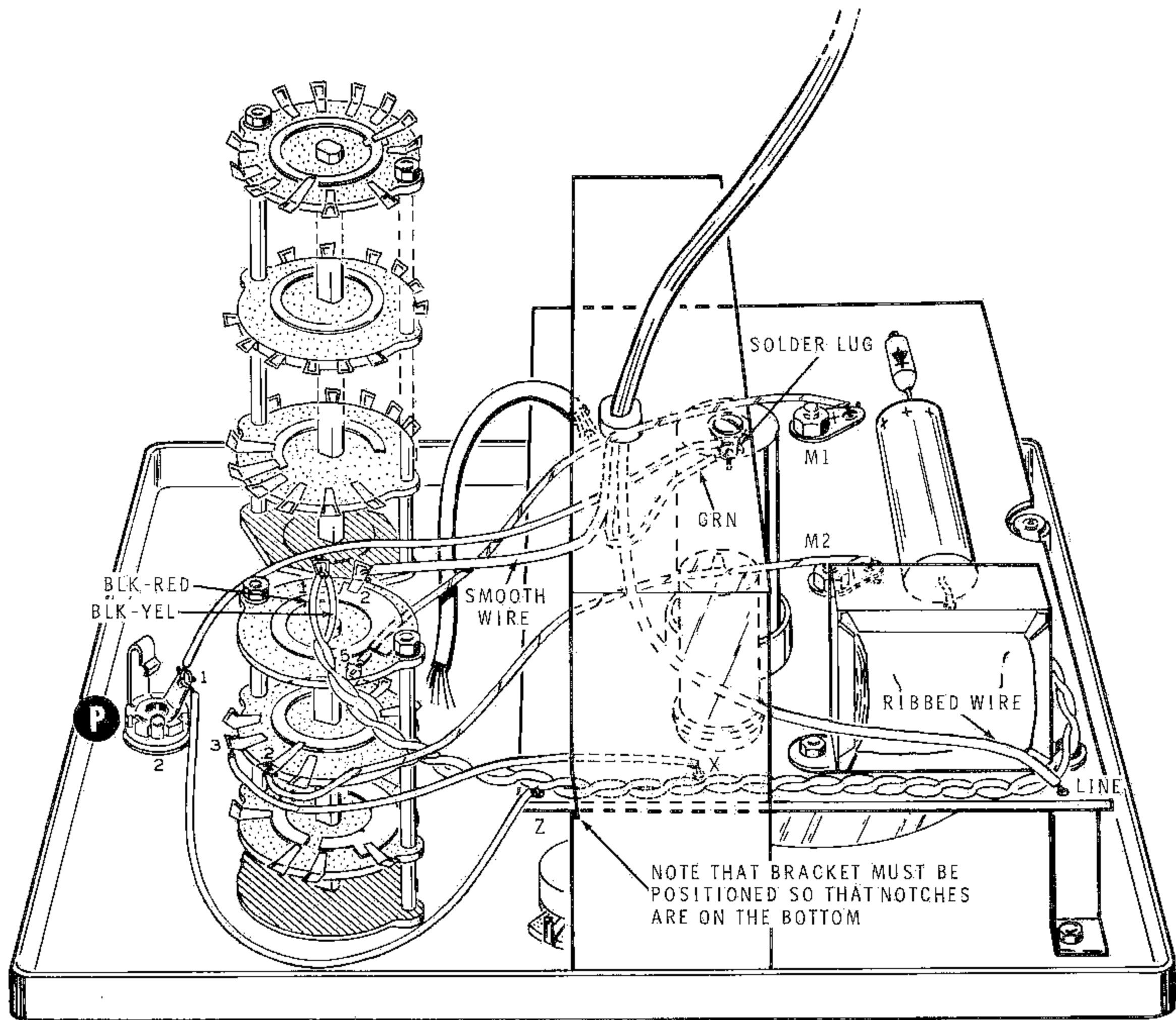

PICTORIAL 5

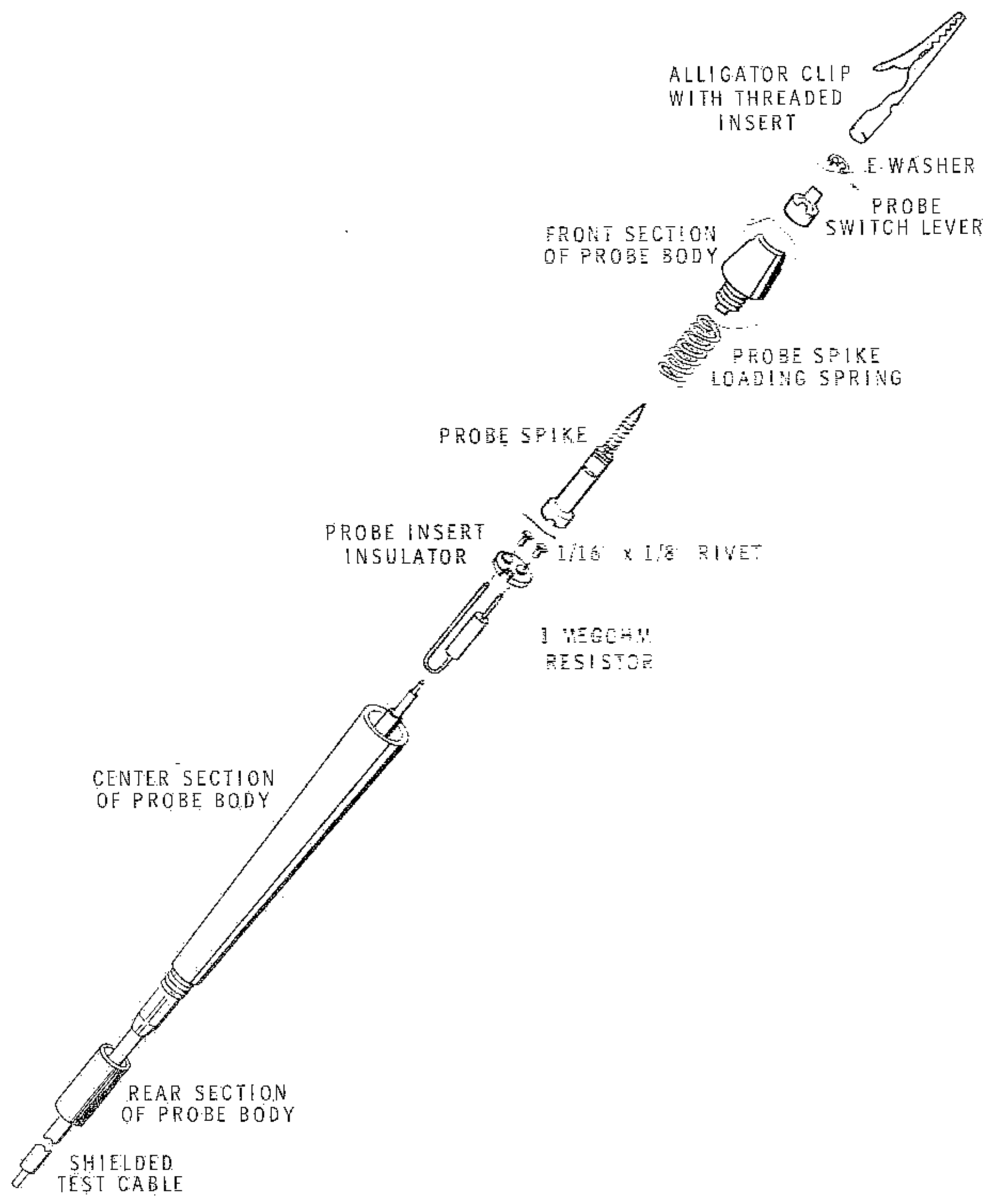

PICTORIAL 7

NOTES:

1. ALL SWITCHES VIEWED FROM REAR.
2. RANGE SWITCH IN 1.5V POSITION.
3. FUNCTION SWITCH IN AC POSITION.
4. ALL RESISTOR VALUES IN OHMS (K=100, M=1,000,000).
5. ALL RESISTORS ARE 1/2 WATT UNLESS OTHERWISE SPECIFIED.
6.  INDICATES SCREWDRIVER ADJUSTMENT.
7. ALL VOLTAGES MEASURED WITH A VTVM OR 20,000 OHMS/VOLTMETER

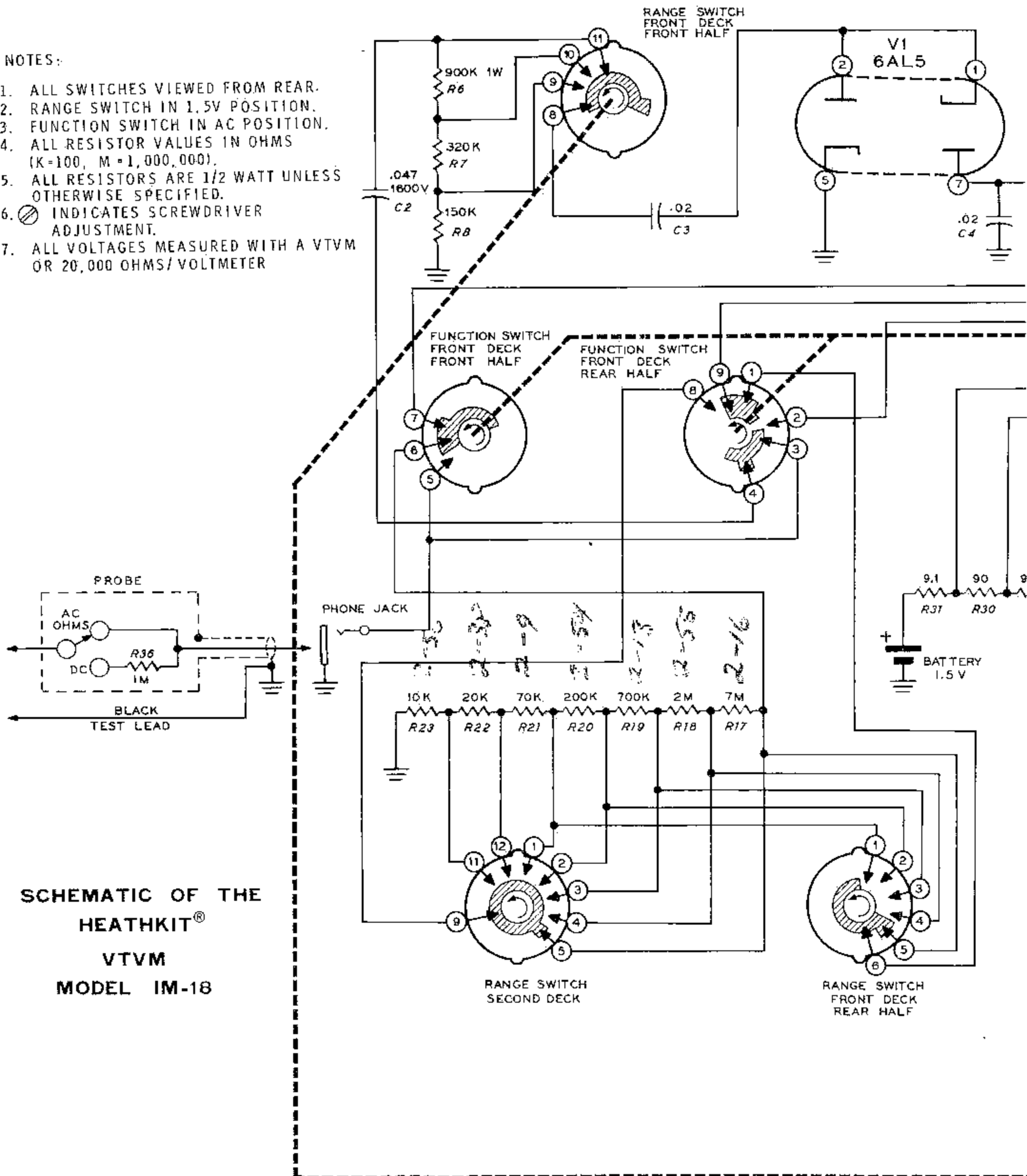

**SCHEMATIC OF THE
HEATHKIT®
VTVM
MODEL IM-18**

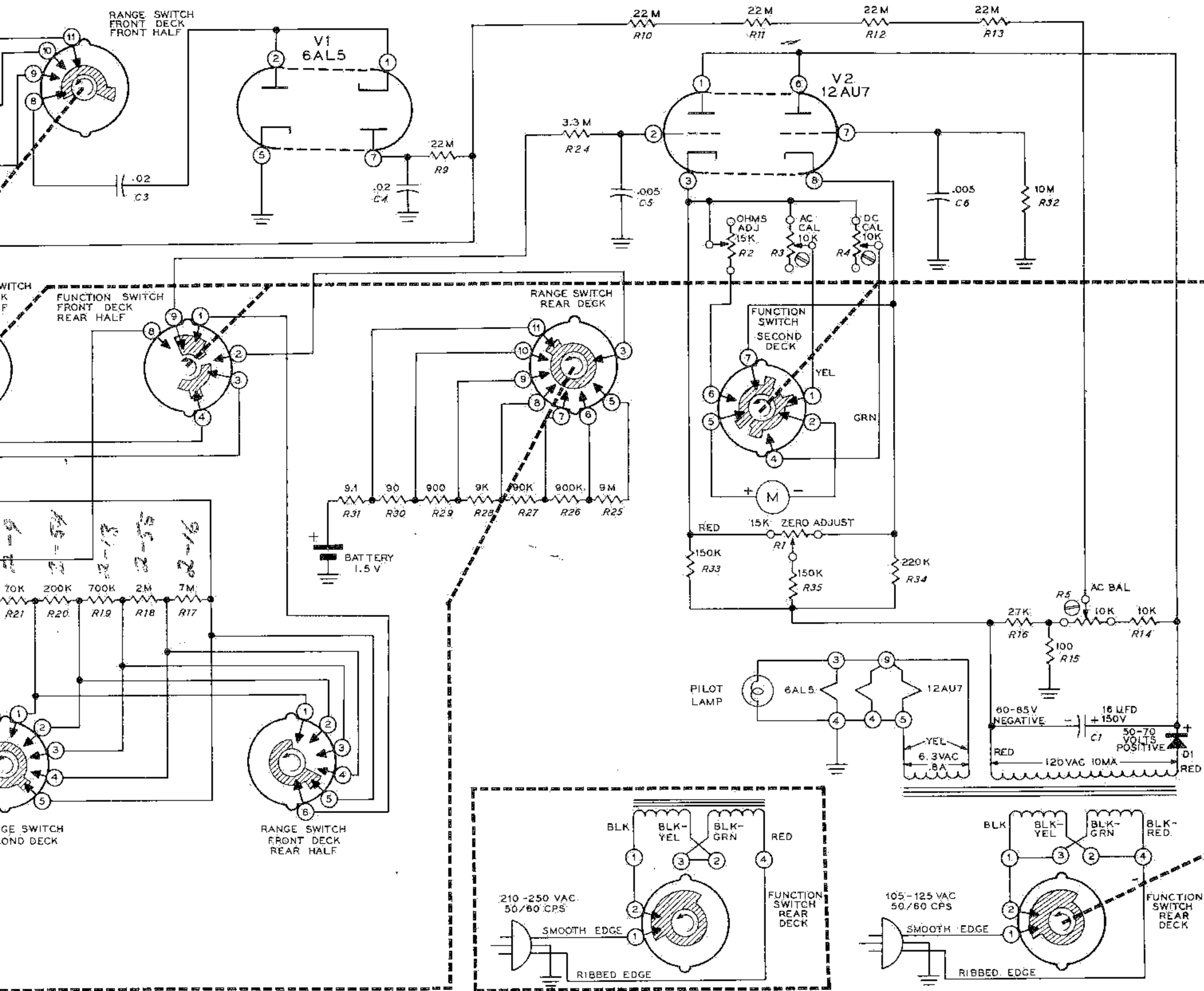

HEATH COMPANY

THE WORLD'S FINEST ELECTRONIC EQUIPMENT IN KIT FORM

LITHO. IN U. S. A.